



1949-51

*Lincoln*

and *Lincoln*

**C O S M O P O L I T A N**

M A Y , 1 9 5 2

**CHASSIS  
PARTS**

**C A T A L O G U E**

L I N C O L N - M E R C U R Y  
D I V I S I O N O F F O R D M O T O R C O M P A N Y  
D E T R O I T , M I C H I G A N



1949-51

*Lincoln*  
and *Lincoln*  
**COSMOPOLITAN**

M A Y , 1 9 5 2

**CHASSIS  
PARTS**

**C A T A L O G U E**

L I N C O L N - M E R C U R Y  
D I V I S I O N O F F O R D M O T O R C O M P A N Y  
D E T R O I T , M I C H I G A N

Identification Data	IV
Alphabetical Index	VII
Wheels, Hubs and Drums	1
Brakes	3
Front Suspension	19
Steering Linkage	23
Steering Gear	24
Rear Axle	34
Frame	42
Muffler	47
Springs	49
Cylinder and Engine Supports	57
Transmission Overdrive	83
Transmission	90
Hydra-Matic Transmission	95
Clutch	131
Cooling System	137
Fuel System	164
Generator	195
Battery	203
Starter	209
Ignition Coil, Distributor	213
Lamps	220
Wiring	236
Fenders	258
Hood	267
Windshield Wiper	279
Bumpers	287
Shock Absorbers	299
Accessories	327
Miscellaneous Kits	357

FORM 3642-51

# LINCOLN—MERCURY

## Division of FORD MOTOR COMPANY

### Detroit, Michigan

#### United States District Offices

District	Location	Lincoln-Mercury District Office	Lincoln-Mercury Sales Office	Lincoln-Mercury Parts Depot
Atlanta, Ga.	Hapeville, Ga.		X	X
Boston, Mass.	Boston, Mass.	X	X	X
Buffalo, N. Y.	Buffalo, N. Y.	X	X	
Chester, Pa.	Chester, Pa.	X	X	X
Chicago, Ill.	Chicago, Ill.	X	X	X
Cincinnati, Ohio	Cincinnati, Ohio	X	X	
Cleveland, Ohio	Cleveland, Ohio	X	X	
Dallas, Texas	Dallas, Texas	X	X	X
Dearborn, Mich.	Detroit, Mich.	X	X	X
Denver, Colo.	Denver, Colo.	X	X	X
Des Moines, Iowa	Des Moines, Iowa	X	X	X
Edgewater, N. J.	Edgewater, N. J.			X
Fargo, N. D.	Fargo, N. D.			X
Houston, Texas	Houston, Texas		X	X
Jacksonville, Fla.	Jacksonville, Fla.	X	X	X
Kansas City, Mo.	Kansas City, Mo.	X	X	
Los Angeles, Calif.	Los Angeles, Calif.	X	X	X
Memphis, Tenn.	Memphis, Tenn.	X	X	X
New Orleans, La.	Arabi, La.			X
New York, N. Y.	New York, N. Y.	X	X	
Richmond, Va.	Richmond, Va.			X
Oakland, Calif.	Oakland, Calif.	X	X	
Oklahoma City, Okla.	Oklahoma City, Okla.			X
Omaha, Neb.	Omaha, Neb.			X
Pittsburgh, Pa.	Pittsburgh, Pa.	X	X	
Richmond, Calif.	Richmond, Calif.			X
St. Louis, Mo.	Robertson, Mo.	X	X	X
Salt Lake City, Utah	Salt Lake City, Utah			X
Seattle, Wash.	Seattle, Wash.	X	X	X
Twin City (St. Paul, Minn.)	St. Paul, Minn.	X	X	X
Washington, D. C.	Washington, D. C.	X	X	

## GENERAL INFORMATION

Attaching parts such as bolts, screws, clamps, etc. are listed below the part with which they are used. All standard bolts, screws, etc. are listed numerically on page 319.

Special bolts, screws, washers, etc. which are other than standard are listed numerically on page 323.

For rapid identification of parts for assemblies, such as, Steering Column Gear Shifts, Carburetors, Generators, Voltage Regulators, Starters, etc. parts have been listed in chart form. When referring to these charts, it is essential to first determine which assembly requires the replacement, then refer to the chart and select the part or parts wanted.

For example: A Starter Armature Assembly is required for a Lincoln Cosmopolitan with HYDRA-MATIC Transmission.

(1) Refer to the numerical listing of Starter Assembly (basic part number 11002) which is shown on page 209 and note that the part number of a Starter Assembly used on a Lincoln Cosmopolitan with HYDRA-MATIC Transmission is 8EL-11002-B.

(2) Refer to Starter Chart, page 209, and note that the part number of an Armature Assembly used with 8EL-11002-B Starter is 52-11005, the wanted part.

The driver's side is the left hand side of the vehicle and governs such parts as fenders, lamps, etc. as to whether a part is right hand or left hand.

Illustrations throughout this catalogue are for a particular model, however, the basic part numbers are applicable to practically all models.

When ordering parts always give full part number and name of each part. Also specify how shipments are to be made, Freight, Express or Parcel Post.

We list below a brief General Telegraphic Code covering miscellaneous instructions relative to the shipment of parts.

ABSEN—Ship via air express.

ABSIN—Rush by air mail.

ANGRA—Express at once.

ANILE—Express direct to.

BEAGA—Post today sure.

BOOBA—Ship fast freight.

BORIK—Ship today sure.

BOSTO—Ship on next plane.

BREWA—Advise how and when shipping.

\*Lincoln-Mercury Division and Ford Motor Company basic part numbers are grouped according to their function, for example all parts applying to the rear axle are grouped from 4000 to 4799, transmission from 7000 to 7449, etc.

Following is an index of the various groups:

SERIES	GROUP	SERIES	GROUP
1000-1250	Wheels, Hubs & Drums	9900- 9999	Carburetor
1351-1499	Spare Wheel Carrier	10000-10449	Generator
2001-2449	Brakes (Service)	10500-10653	Cutout and Voltage Regulator
2450-2597	Brake (Controls)	10654-10747	Battery
2600-2970	Brakes (Hand)	10841-10990	Instrument Cluster & Ammeter
3000-3451	Front Axle	11000-11516	Starter Motor
3500-3743	Steering Gear	11520-11688	Lighting Switch
4000-4799	Rear Axle & Drive Shaft	12000-12327	Ignition Coil, Distributor, Condenser
4800-4999	Coupling Shaft	12405-12425	Spark Plug
5000-5149	Frame & Brackets	13002-13399	Head and Parking Lamps
5150-5224	Battery Brackets & Parts	13400-13799	Rear Luggage Compartment, License, Courtesy and Dome Lamps
5225-5299	Muffler & Exhaust Pipe		
5300-5515	Front Springs	13800-13919	Horn
5550-5818	Rear Springs	14054-14621	Wiring
6000-6928	Engine	15000-15856	Miscellaneous Accessories
7000-7449	Transmission	16000-16211	Front Fender
7500-7646	Clutch	16312-16446	Rear Fender
8000-8499	Radiator	16600-16964	Hood
8500-8599	Water Pump	17003-17125	Tools
8600-8648	Fan	17250-17320	Speedometer
8700-8734	Air Ventilator	17450-17599	Windshield Wiper
9002-9299	Fuel Tank	17679-17742	Mirrors
9270-9420	Fuel Pump	17744-17999	Bumpers
9421-9499	Manifolds, Clamps, etc.	18000-18129	Shock Absorbers
9500-9699	Carburetor	18140-19586	Miscellaneous Accessories
9700-9833	Acc. & Choke Control Rods		

\*There are a few exceptions to the above and when these do occur the part is assigned an extra first digit corresponding to the first digit of the group in which the part belongs.

Example: 8CM-99525 Carburetor float and float spring kit.

# MODEL IDENTIFICATION

## *Lincoln and Lincoln Cosmopolitan*

### 1949

#### *Lincoln*

9 L Series—121" W. B.

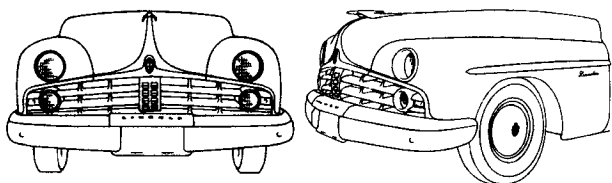

BODY TYPE	NAME
72	Six Passenger Coupe
74	Sport Sedan
76	Six Passenger Convertible Coupe

#### *Lincoln Cosmopolitan*

9 H Series—125" W. B.

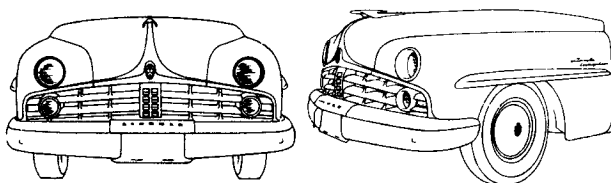

BODY TYPE	NAME
72	Six Passenger Coupe
73	Town Sedan
74	Sport Sedan
76	Six Passenger Convertible Coupe

### 1950

#### *Lincoln*

OL Series—121" W. B.

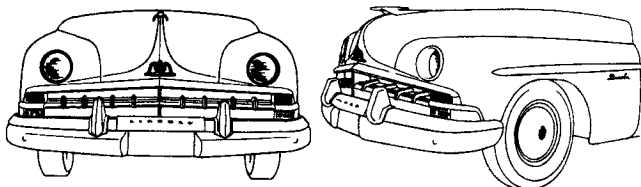

BODY TYPE	NAME
72	Six Passenger Coupe
72-C	Six Passenger Coupe (Custom)
74	Sport Sedan

#### *Lincoln Cosmopolitan*

OH Series—125" W. B.

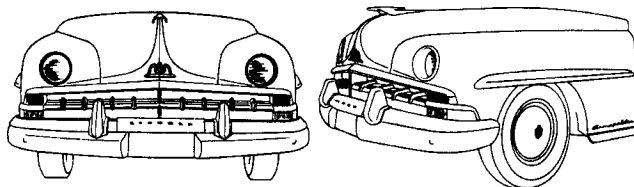

BODY TYPE	NAME
72	Six Passenger Coupe
72-C	Six Passenger Coupe (Custom)
74	Sport Sedan
76	Six Passenger Convertible Coupe

# MODEL IDENTIFICATION

## *Lincoln and Lincoln Cosmopolitan*

### 1951

#### *Lincoln*

IL Series—121" W. B.

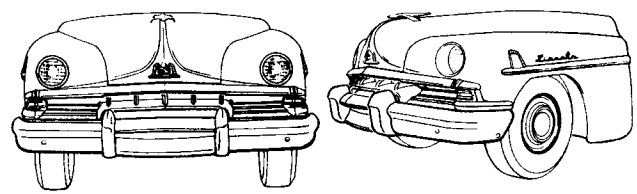

BODY TYPE	NAME
72-B	Six Passenger Coupe
74	Sport Sedan

#### *Lincoln Cosmopolitan*

IH Series—125" W. B.

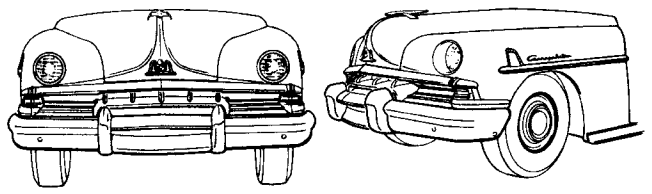

BODY TYPE	NAME
72-B	Six Passenger Coupe
74	Sport Sedan
76	Six Passenger Convertible Coupe

# ABBREVIATIONS

accel.	.....	accelerator	L.H.	.....	Left Hand
adj.	.....	adjusting	L.H.D.	.....	Left Hand Drive
alum.	.....	aluminum	lic.	.....	license
approx.	.....	approximately	L/W	.....	lockwasher
assy.	.....	assembly	lub.	.....	lubricator
aux.	.....	auxiliary	mach.	.....	machine
brg.	.....	bearing	man.	.....	manifold
brkt.	.....	bracket	mldg.	.....	moulding
b-hd	.....	button head	mount. or (mtg.)	.....	mounting
C.P.	.....	candle power	O/Drive	.....	overdrive
carb.	.....	carburetor	O.D.	.....	outer diameter
compt.	.....	compartment	o/all	.....	overall
conn.	.....	connecting	O/S	.....	oversize
c/pin.	.....	cotter pin	pass.	.....	passenger
coup. or (cplg.)	.....	coupling	ptd.	.....	painted
c/shaft	.....	crankshaft	rad.	.....	radiator
cyl.	.....	cylinder	reinf.	.....	reinforcement
defl.	.....	deflector	reg.	.....	regulator
def.	.....	defroster	rep.	.....	replaced
dia.	.....	diameter	req'd	.....	required
diff.	.....	differential	ret.	.....	retainer
D.C.	.....	double contact	R.H.	.....	Right Hand
dist.	.....	distributor	R.H.D.	.....	Right Hand Drive
econ.	.....	economizer	rd-hd	.....	round head
emer.	.....	emergency	S.C.	.....	single contact
equipt.	.....	equipment	spec.	.....	special
exh.	.....	exhaust	spec-hd	.....	special head
ext.	.....	extension	sq-hd	.....	square head
fl-hd	.....	flat head	std.	.....	standard
ft.	.....	foot or feet	tap.	.....	tapping
gen.	.....	generator	trans.	.....	transmission
H/D	.....	heavy duty	U/S	.....	undersize
hex	.....	hexagonal	univ.	.....	universal
hex-hd	.....	hexagonal head	univ/jt.	.....	universal joint
hsg.	.....	housing	vac.	.....	vacuum
hyd.	.....	hydraulic	vent.	.....	ventilator
I.D.	.....	inner diameter	W/S	.....	windshield
ign.	.....	ignition	w/	.....	with
instr.	.....	instrument	w/o	.....	without
jt.	.....	joint			

## Alphabetical Index

NOTE: All parts in this catalog are listed in numerical sequence. Where the function of a part causes it to be listed out of numerical order it is indented the same as attaching parts and appears again in numerical sequence.

Basic part numbers only are shown in the following "Alphabetical Index". Always refer to Parts Listings for complete Part Number. For example: The basic Part Number of a Piston is 6110; by referring to Parts Listings you will find that 6110 appears numerically on page 65 where the various piston sizes are shown.

## Alphabetical Index

Part Name	Basic Part No.	Part Name	Basic Part No.
<b>-- A --</b>			
Accelerator assembly	9725	Anti Squeak (Strg. column saddle)-Fibre	33680
Accelerator Chart (Page 185)		Anti squeak (support bracket to fender apron)	10738-40
Accelerator Group (Page 185)		Anti squeak (top radiator air deflector)	8404
Accessories Group (Page 327)		Anti squeak (top radiator air deflector)	8412
Adapter (carburetor fuel inlet)	9224	Anti squeak (top radiator air deflector side)	8411
Adapter (fuel pump)	9416	Anti squeak (W/S wiper motor to adaptor)	17563
Adapter (speedometer drive)	17269	Apron assy (front fender)	16054-5
Adapter (spotlight)	15207	Arm (dist. timing)	12274
Adapter (transmission overdrive)	7660	Arm (hood support)	16784-5
✦Adapter (transmission rear pump tube)	77408	Arm (spindle steering)	3130-31
Air Cleaner Group (Page 185)		Arm (steering gear)	3590
Air cleaner and silencer	9600	Arm (steering idler)	3355
Air Ventilator Group (Page 154)		Arm assy (cable drive W/S wiper)	17526
Antenna assy (radio)	18813	Arm assy (fuel and vacuum pump rocker)	9376
Anti freeze	19544	Arm assy (rear window wiper)	17406
Anti rattler (front bumper arm to stone defl.)	17749	Arm assy (windshield wiper)	17526-27
Anti rattler (hood reinforcement to panel)	16739	Arm & inner shaft assy (front suspension)	3042-44
Anti rattler (rear fender brace)	16380	Arm & pivot shaft assy (W/S wiper mounting)	17566
Anti squeak (battery support bracket to fender apron)	10738-9	Armature (regulator)	10551
Anti squeak (battery tray to support)	10740	Armature assy (current limiter)	10584
Anti squeak (engine rear support insulator)	6071	Armature assy (cutout)	10540
Anti squeak (front bumper stone deflector end)	17729	Armature assy (generator)	10005
Anti squeak (front fender apron to brace assy)	16234	Armature assy (starter)	11005
Anti squeak (front fender apron to frame)	16070	Arrestor assy (battery corrosion)	10682
Anti squeak (front fender apron to radiator grille air deflector)	8415	Axle assy (rear)-less brakes & axle shafts	4006
Anti squeak (front fender to brace)	17771	<b>-- B --</b>	
Anti squeak (front fender to cowl side)	16071	Back Up Lamp Group (Page 327)	
Anti squeak (front fender to cowl strainer)	17771	Baffle (front brake grease)	2060
Anti squeak (front fender to front fender apron)	16068	Baffle (instrument cluster dust)	10863
Anti squeak (front fender to radiator grille air deflector)	8403	Baffle (instrument cluster signal lamp)	13589
Anti squeak (fuel tank to hanger)	9299	Baffle (transmission main drive gear)	7040
Anti squeak (hood catch support to radiator grille air deflector)	8413	Baffle (transmission main shaft oil)	7668
Anti squeak (instrument cluster radio grille)	10857	Baffle assy (oil pan)	6683
Anti squeak (radiator grille air deflector to radiator support)	8405	Baffle assy (valve chamber oil)	6524
Anti squeak (radiator grille support to stone deflector and air deflector)	17771	Bag assy (tool)	17005
Anti squeak (radiator splash shield to stone defl.)	16564	Bail assy (fuel pump filter bowl)	9387
Anti squeak (radiator support to front fender apron)	8402	Ball (carburetor accelerator pump check)	9576
Anti squeak (rear fender to body)	16320	Ball assy (trans. gear shift lever)	7213
Anti squeak (rear fender to body)	16346	Ball end (clutch release equalizer shaft)	7543
Anti squeak (rear fender stone deflector)	17855	✦Ball joint assy (ball crank to accel. shaft)	9752
Anti squeak (splash panel to fender)	16070	Band (generator cover)	10142
Anti squeak (splash panel to front fender)	17771	Band assy (starter cover)	11125
Anti squeak (splash shield assy)	6780	✦Band assy (transmission front)	77510
		✦Band assy (transmission rear)	77518
		Bar assy (frame front "K")	5121-2
		Bar assy (rear bumper impact)	17906

✦ Used with HYDRA-MATIC transmission



## Alphabetical Index—Continued

Part Name	Basic Part No.	Part Name	Basic Part No.
Bar (front bumper center impact)	17773	Blade assy (W/S wiper)	17593
Bar (front bumper impact)	17756-57	✦Blade, bracket and pulley assy (fan)	8602
Bar (front bumper impact)-upper	17762	Block assy (cylinder)	6010
Bar (front bumper center impact)	17752	Block assy (electric wiring junction)	14448
Bar (front fender apron & radiator)	16152	Blower assy (fresh air hot water heater)	18456
Bar (instrument cluster bus)	9272	Body (hydraulic tappet)	6502
Bar (radiator grille)	8150	Body (rear lamp)	13441
Bar (radiator grille)	8151	✦Body (transmission front servo)	77415
Bar (radiator grille)	8204	Body (vacuum pump)	99385
Bar (radiator grille)	8241	Body (water pump)	8505-06
Bar (rear bumper impact)	17864-5	Body assy (carb. main)	9512
Bar (rear bumper center impact)	17866-67	Body assy (fuel pump upper)	9354
Bar (rear spring shackles)	5627	Body assy (oil pan)	6676
Bar (stabilator)	5494	Body assy (oil pump)	6603
Base, bushings, oiler & clamps assy (dist.)	12130	Body assy (rear lamp)	13408
Battery assy	10655		
Battery Clamp Group (Page 46)		✦Body assy (transmission front servo)	77404
Battery Group (Page 203)		Body assy (trans. front servo exhaust valve)	77409
Bearing (camshaft front & intermediate)	6262	✦Body assy (trans. oil control valve inner)	77476
Bearing (camshaft rear)	6263	✦Body assy (trans. oil control valve outer)	77601
Bearing (clutch pilot)	7600	✦Body assy (transmission rear servo)	77444
Bearing (connecting rod)	6211	✦Body assy (trans. rear servo accumulator)	77454
Bearing (fan spindle)	8626	Body assy (vacuum pump)	99385
Bearing (front main)	6338	Body assy (W/S wiper auxiliary drive)	17579
Bearing (generator)	10094	Body & oil seal assy (fuel pump lower)	9375
Bearing (generator oilless)	10128	Body & plugs assy (carburetor main)	9512
Bearing (intermediate main)	6342	Body & plugs assy (carburetor throttle)	9518
Bearing (rear main)	6331	Body & shaft assy (carburetor throttle)	9518
Bearing (rear wheel)	1225	Body & wiring (parking lamp)	13206-7
✦Bearing (servo actuating lever pin needle)	77144	Body, lens and reflector assy (rear lamp)	13417
Bearing (starter brush & plate)	11052	Bolt (battery clamp)	5175
Bearing (strg. gear shaft)	33576	Bolt (front and rear bumper)	17758
Bearing (transmission countershaft gear)	7121	Bolt (crankshaft bearing)	6346
Bearing (transmission generator shift socket)	7225	Bolt (cylinder head)	6066
Bearing (transmission main drive gear)	7025	✦Bolt (flywheel housing to transmission)	77008
Bearing (transmission mainshaft)	7697	✦Bolt (flywheel to crankshaft)	6379
✦Bearing (transmission pilot)	7938	Bolt (front brake housing)	2056
Bearing (transmission reverse idler gear)	7143	Bolt (front brake line connector)	2150
Bearing (transmission shaft pilot)	7120	Bolt (front suspension arm to spindle support)	3072-3
Bearing (universal joint)	7074	Bolt (generator frame thru)	10120
Bearing assy (ball)-trans. drive gear	7025	Bolt (hex-hd-dog point)	77312
Bearing assy (clutch release)	7580	Bolt (hex head starter thru)	11091
Bearing assy (rear axle differential)	4220	Bolt (rear axle brake housing)	2248
Bearing assy (spindle bolt)	3123	Bolt (rear brake cylinder connection)	2276
Bearing assy (steering column)	3517	Bolt (spare wheel carrier)	1447
✦Bearing assy (transmission output shaft)	77141	Bolt (spindle support clamping)	3067
Bearing & slinger assy (water pump)	8578	Bolt (starter through)	11091
✦Bell crank (accelerator)	9732	Bolt (steering column bracket "U")	3668
Belt (fan)	8577	✦Bolt (torus cover to crankshaft assy)	7943
Bezel (fresh air hot water heater switch and antenna control)	18598	✦Bolt (trans. reverse anchor support)	77136
Belt (generator)	8620	Bolt (universal joint "U")	4529
Bezel (clock)	15010	Bolt (wheel hub)	1107
Bezel (headlamp control switch)	11662	✦Bolt & washer assy (trans. side cover to case)	77226
Bezel (instrument cluster radio push button)	10859	Boot (brake master cylinder)	2180
Bezel (radio control)	18842	Boot (roadlamp adjusting nut)	15227
Bezel (radio antenna control)	18926	Boot (steering column to instrument panel)	33677
Bezel (roadlamp switch)	15268	Boot (wheel brake cylinder)	2206
Bezel (speedometer & instrument cluster)	10862	Boss (oil filter return pipe to oil pan)	6692
Bezel (windshield wiper control)	17482	Bowl (fuel pump filter)	9355
Bezel assy (ignition switch)	11580	Brace (air cleaner)	9663
Blade assy (fan)	8600	Brace (frame side member to rear cross member)	5067-8
Blade assy (rear window wiper)	17402	Brace (front bumper end to frame)	17784
Blade assy (W/S wiper)	17528	Brace (front bumper end to frame)	17785
		Brace (rear bumper end)	17789

✦ Used with HYDRA-MATIC transmission

## Alphabetical Index—Continued

Part Name	Basic Part No.	Part Name	Basic Part No.
Brace (rear bumper to frame)	17789	Bracket assy (radio antenna vacuum)	18965
Brace (rear fender)	16340-1	Bracket assy (tire inflator & fire extinguisher)	17942
Brace (rear fender)	16446	Bracket assy (turn signal flasher)	13348
Brace assy (front fender)	16096-7	Bracket & control handle assy (automatic temperature regulator)	18511
Brace & bracket assy (front fender)	16094-5	✦Bracket & crank assy (trans. reverse shifter)	77295
Bracket (accelerator bellcrank)	99771	Bracket & insulator assy (muffler outlet pipe)	5259
Bracket (air duct support)	8724	Bracket & insulator assy (muffler outlet pipe)	5273
Bracket (back up lamp switch mounting)	15517	Bracket & nut assy (clutch release equalizer shaft)	7568
Bracket (body hinge pillar to fender)	16222	Brake assy (front)	2010-11
Bracket (cable drive W/S wiper clamp)	17546	Brake assy (rear)	2209-10
Bracket (cowl side panel to fender support)	16298-9	Brake pedal	2452
Bracket (crankcase vent. tube)	6821	Breaker assy (distributor)	12150
Bracket (fan mounting)	8632	Breaker and bracket assy (circuit)	12258
Bracket (frame to body)	5075	Breaker arm and bracket assy (distributor)	12171
Bracket (frame to body)	5078	Brush (dist. terminal housing)	12122
Bracket (fresh air heater blower)	18543	Brush assy (generator)	10069
Bracket (fresh air hot water heater hose support)	18481	Brush assy (starter)	11055
Bracket (front brake hose)	2082	Brush assy (starter ground)	11056
Bracket (front fender to apron)	16092	Bulb (backing lamp)	13465
Bracket (hand brake cable)-front	2153	Bulb (beam indicator)	15021
Bracket (hand brake cable)-rear	2530-1	Bulb (cigar lighter lamp)	15021
Bracket (hand brake lever)	2795	Bulb (clock)	13466
Bracket (heater hose support)	18481	Bulb (courtesy lamp rear compartment)	13987
Bracket (hood control)	16930	Bulb (courtesy light)	13464
Bracket (hood upper hinge)	16678	Bulb (dome lamp)	13464
Bracket (hood & top control)	16930	Bulb (dome lamp)	13730
Bracket (ignition cable mounting)	12111-12	Bulb (dome lamp)	13799
Bracket (ignition switch light)	3765	Bulb (engine compartment lamp)	13799
Bracket (inside rear view mirror)	17684	Bulb (glove box)	13466
Bracket (O/Drive control to instrument panel)	4120	Bulb (hand brake signal)	13466
Bracket (quarter panel wheel opening cover)	7228000	Bulb (instrument cluster)	13466
Bracket (quarter panel wheel opening cover)	7228001	Bulb (license plate lamp)	13466
Bracket (quarter panel wheel opening cover)	7228002	Bulb (luggage compartment lamp)	13466
Bracket (quarter panel wheel opening cover)	7228003	Bulb (map light)	13464
Bracket (radiator grille bar to fender)	8458	Bulb (map light)	13730
Bracket (radiator support)	5073	Bulb (parking lamp)	13465
Bracket (radiator support to fender apron)	8046-47	Bulb (rear lamp)	13465
Bracket (radio antenna)	18939	Bulb (roadlamp)	15220
Bracket (radio antenna vacuum)	18965	Bulb (speedometer)	13466
Bracket (rear brake hose)	2073	Bulb (tail & parking light)	13730
Bracket (spotlight)	15321	✦Bulb (transmission gear shift indicator)	15021
Bracket (spotlight)	18576	Bulb (turn indicator)	15021
Bracket (stabilator to frame)	5486	Bulb (utility lamp)	13465
Bracket (stabilator to spindle support)	5499	Bulb (utility lamp)	18570
Bracket (starting motor)	11140	Bulb assy (electric heat indicator)	10884
Bracket (steering column)	3678	Bulb assy (engine excessive heat indicator)	10990
Bracket (steering idler arm)	3351	Bulb assy (headlamp)	13007
Bracket (suspension arm & shock mounting)	5022	Bulb assy (spotlight)	15330
Bracket (tire inflator & fire extinguisher)	17942	Bumper (fender to hood)	16758
Bracket (ventilating dust support)	8719	Bumper (front suspension rebound)	3025
Bracket (voltage regulator mounting)	10666	Bumper (hood front to grille)	700546
Bracket (W/S washer dash control mounting)	17614	Bumper (hood front to grille)	7023030
Bracket assy (clutch release equalizer shaft)	7507	Bumper (rear fender filler neck lid)	16378
✦Bracket assy (engine front support)	6028-9	Bumper (rear fender filler neck lid)-rear	7306066
Bracket assy (engine rear support)	5059	Bumper assy (floor pan)	5783
Bracket assy (front license)	5034	Bumper assy (front suspension lower arm)	3020
Bracket assy (hand brake signal lamp)	15853	Bumper assy (rear axle)	5783
Bracket assy (horn)	13830-1	✦Bushing (accelerator bell crank stud)	99745
Bracket assy (inside rear view mirror)	17684	Bushing (brake and clutch pedal)	7526
Bracket assy (luggage compartment spare wheel mtg.)	7247070	Bushing (camshaft fuel pump drive eccentric)	6281
Bracket assy (muffler outlet pipe)	5261		

✦ Used with HYDRA-MATIC transmission

## Alphabetical Index—Continued

Part Name	Basic Part No.	Part Name	Basic Part No.
Bushing (clutch release shaft)	7508	+Carrier assy (transmission front planet)	77180
Bushing (cutout unit resistor insulating)	10621	+Carrier assy (transmission reverse planet)	77140
Bushing (distributor)	12132	Cartridge assy (air filter ventilation tube)	6841
Bushing (distributor base)	12120	Case (differential gear)	4205
Bushing (distributor primary terminal)	12233	Case (transmission)	7006
Bushing (exhaust and intake guide)	6510	+Case assy (transmission)	7005
Bushing (front wheel spindle pin)	3110	Cement (Rubber)	19552
Bushing (fuel & vacuum pump rocker arm)	9389	Chart - Accelerator (Page 185)	
Bushing (generator field terminal insulator)	10202	Chart - Carburetor (Page 176)	
+Bushing (heat tube to intake manifold)	9888	Chart - Cutout And Voltage Regulator (Page 201)	
Bushing (oil pump)	6612	Chart - Frame (Page 44)	
Bushing (oil pump drive idler)	6657	Chart - Front Main Bearing Liner (Page 71)	
Bushing (piston pin)	6207	Chart - Generator (Page 197)	
Bushing (rear spring shackle)	5719	Chart - HYDRA-MATIC (Page 96)	
Bushing (shock absorber rubber insulator)	18197	Chart - Intermediate Main Bearing Liner (Page 71)	
Bushing (spindle support)	3046	Chart - Rear Axle (Page 37)	
Bushing (spindle support)	3089	Chart - Rear Main Bearing Liner (Page 70)	
Bushing (stabilator to spindle support)	5496	Chart - Rear Shock Absorber Stud (Page 300)	
Bushing (starter rear end plate)	11135	Chart - Rear Spring Clip (Page 53)	
Bushing (steering worm sector)	3576	Chart - Rear Spring Inner Clamp (Page 55)	
Bushing (valve guide)	6510	Chart - Rear Spring Outer Clamp (Page 54)	
Bushing assy (front suspension arm inner shaft)	3062-3	Chart - Speedometer Casing & Shaft (Page 277)	
Bushing assy (steering idler arm)	3356	Chart - Steering Column Gear Shift (Page 120)	
Button (radio knob opening plug)	18856	Chart - Starter (Page 209)	
		Chart - Starter Drive (Page 212)	
		Chart - Water Pump (Page 151)	
		Choke assy (automatic)	9851
		Circuit breaker and bracket assy	12258
		Circuit breaker assy (hydraulic system)	14526
		Clamp (air duct retainer)	8725
		Clamp (back up lamp wiring)	18954
		Clamp (carb. automatic choke thermostat housing)	9842
		Clamp (crankcase ventilation tube)	6828
		Clamp (direction signal flasher)	13351
		Clamp (distributor terminal housing)	12144
		Clamp (engine compartment lamp wire)	18954
		Clamp (fresh air hot water heater hose)	18572
		Clamp (muffler inlet pipe)	5270
		Clamp (muffler inlet pipe)	5298
		Clamp (muffler outlet pipe)	5260
		Clamp (muffler outlet pipe)	5280
		Clamp (radio antenna hose)	18954
		Clamp (rear lamp mounting)-lower	13518
		Clamp (rear lamp mounting)-upper	13516-7
		Clamp (roadlamp wire)	15226
		Clamp (roadlamp wiring)	18954
		Clamp (spare wheel & tire)	1446
		Clamp (spare wheel and tire)	7347074
		Clamp (spindle connecting rod)	3287
		Clamp (steering column)	3507
		Clamp (W/S washer hose)	18954
		Clamp assy (air duct retainer)	8725
		Clamp assy (battery)	5165
		Clamp assy (battery drain hose to tray)	7324289
		Clamp assy (carburetor air cleaner)	9628
		Clamp assy (fuel tank filler hose)	8287
		Clamp assy (fuel tank vent pipe hose)	9171
		Clamp assy (neutral spring to strg. column)	8287
		Clamp assy (radiator hose)	8287
		Cleaner (body)	19520
		Cleaner (chrome)	19522

### —C—

Cable and conduit assy (hand brake)	2275
Cable and conduit assy (hand brake)	2853
Cable assy (battery to ground)	14301
Cable assy (battery to starter relay)	14300
Cable assy (dash to engine)	14303
Cable assy (fresh air inlet)	7201890-1
Cable assy (fresh air inlet)	7301890-1
Cable assy (hood catch control)	16916
Cable assy (relay to starter)	14431
Cable assy (speedometer)	17260
Cable assy (starter solenoid to pump solenoid)	14506
Cable and shaft assy (speedometer)	17260
Cage assy (transmission overdrive pinion)	7673
Cam (directional signal turn off)	13318
Cam assy (carburetor fast idle)	9597
Cam assy (distributor)	12210
Cam & shaft (trans. high & inter.)	7280
Cam & shaft (trans. low & reverse)	7282
Cam, roller & cage assy (trans. overdrive free wheel)	7675
Camshaft assy	6251
Camshaft and Crankshaft Group (Page 67)	
Cap (front hub grease)	1139
Cap (fuel tank)	9030
Cap (generator rear end plate)	10118
Cap (oil relief valve)	6666
Cap (wheel hub)	1137
Cap assy (brake master cylinder filler)	2162
Cap assy (breather filler)	6766
Cap assy (radiator)	8100
Cap assy (wheel hub)	1130
Cap & emblem assy (steering wheel)	3623
Carburetor assy	9510
Carburetor Chart (Page 176)	
Carburetor Group (Page 172)	

+ Used with HYDRA-MATIC transmission

## Alphabetical Index—Continued

Part Name	Basic Part No.	Part Name	Basic Part No.
Cleaner (spot remover)	19521	Clip (rear spring)	5705
Cleaner (upholstery foam)	19526	Clip (rear spring)	5724-5
Cleaner (white side wall tires)	19523	Clip (roadlamp wire to fender apron)	18954
Cleaner and polish (body)	19518	Clip (roadlamp wire to stone deflector)	14197
Cleaner, polish and wax (body)	19519	Clip (roadlamp wiring loom)	15233
Clevis (hood support spring)	16884	Clip (rod end clevis)	9825-6
✦ Clevis (manual shift rod)	7354	Clip (speedometer cable to frame)	14585
Clip (accelerator pedal retracting spring)	9816	Clip (starter solenoid to hydraulic pump solenoid)	14550
Clip (accelerator rod end clevis)	9825	Clip (starter solenoid to pump solenoid)	14197
✦ Clip (accelerator shaft & bracket to bell crank rod end clevis)	9826	Clip (steering wheel emblem)	3661
Clip (air control to glove compartment)	14599	Clip (stoplight switch wire)	14197
Clip (attach fuel gauge wire to fuel tank)	14599	Clip (temperature control to regulator control bracket)	16899
Clip (back up lamp wire)	14586	Clip (trans. O/Drive control cable support)-at engine	7713
Clip (battery to starter relay cable)	14197	Clip (vent air control to bracket)	16899
Clip (battery to starter relay cable)	14550	Clip (window solenoid switch wiring to cyl. brkt.)	14585
Clip (brake pipe to rear axle)	2244	Clock Group (Page 255)	
Clip (cigar lighter wiring)	14598	Clock assy (electric)	15000
Clip (cigar lighter wiring to front seat frame)	10882	Cluster assy	10849
Clip (cigar lighter wiring to tank moulding mounting bolt)	9296	Cluster assy (instrument)-less instruments	9271
Clip (cowl wiring to left fender apron)	14199	Clutch Group (Page 131)	
Clip (cowl wiring to right fender apron)	14197	✦ Clutch (rear drum assy)	77187
Clip (defroster control to regulator control brkt.)	16899	Coating (Chrome)	19514
Clip (distributor breaker arm spring)	12316	Cock (radiator drain)	8115
Clip (electrical wiring)	14577	Coil assy (generator field)	10175
Clip (foot switch wiring to rear fender apron)	14586	Coil assy (ignition)	12029
Clip (fresh air control cable)	18590	Coil assy (starter field)	11083-85
Clip (fresh air regulator control)	18590	Collar (distributor shaft)	12195
Clip (front brake pipe to cross & side member)	14197	Compound (body porcelainize)	19528
Clip (front fender moulding)	16209-11	Condenser assy (distributor coil)	12300
Clip (front hand brake cable)	14598	Conduit (ignition cable)	12110
Clip (front hand brake cable to frame)	17264	Conductor assy (ventilating air)	8702
Clip (fuel line to dash)	9296	Cone (trans. reverse clutch stationary)	77591
Clip (fuel line to frame)	14197	Cone & roller (front wheel bearing)	1216
Clip (hand brake cable to fender apron)	14565	Cone & roller (front wheel bearing)	1201
Clip (hand brake cable)	2279	Cone & roller assy (rear axle differential)	4221
Clip (hand brake cable spring lock)	2814	Cone & rollers (rear axle driving pinion bearing)	4621
Clip (hand brake front cable)	17264	Cone & roller assy (rear axle driving pinion bearing)	4630
Clip (headlamp & ignition wire harness)	14577	Connecting link & ball stud assy (steering)	3304
Clip (headlamp & parking lamp wiring to fender apron)	14199	Connection (distributor diaphragm vacuum)	12382
Clip (headlamp wire to air deflector)	14197	Connection (W/S wiper tube "T")	17439
Clip (headlamp wiring to apron)	14281	Connection assy (cylinder head water outlet)	8592-93
Clip (hood lock cable)	16899	Connector (fresh air hot water heater blower)	18584
Clip (hood ornament center)	16603	Connector (fresh air inlet duct)	18584
Clip (hydraulic pump cable to front cross member)	14550	Connector (front brake line)	2075
Clip (hydraulic seat regulator wiring to floor pan)	14592	Connector (rear brake line)	2074
Clip (hydraulic tubing)	14577	Connector (vent air duct)	7201878
Clip (instrument panel wiring)	14197	Connector (vent air duct)	7001879
Clip (instrument wiring to panel instrument)	14550	Connector (wire & sleeve)	14487
Clip (luggage compartment wire)	14197	Connector assy (generator brush)	10037
Clip (luggage compartment wiring)	14586	Connector assy (terminal)	14487
Clip (oil filler tube)	6738	Connector & insulator assy (terminal)	14487
Clip (overdrive control cable)	4296	Control (air regulator)	18646
Clip (overdrive control cable)	14550	Control assy (air regulator)	18646
Clip (package tray wiring)	14586	Control assy (cable drive W/S wiper)	17470
Clip (parking lamp)	13213	Control assy (fresh air heater defroster)	18548
Clip (parking lamp)	13214	Control assy (fresh air hot water heater temperature)	18518
Clip (quarter panel wheel cover)	7328006	Control assy (fresh air hot water heater temperature regulator)	18549
Clip (rear brake hose to frame bracket)	2814	Control assy (fresh air regulator)	18561
Clip (rear cigar lighter wiring to front seat back)	10882	Control assy (hand brake)	2780
Clip (rear lamp wiring)	14586		

✦ Used with HYDRA-MATIC transmission

## Alphabetical Index—Continued

Part Name	Basic Part No.	Part Name	Basic Part No.
		<b>--D--</b>	
Control assy (rear window wiper)	17407	Dampener assy (crankshaft)	6316
Control assy (transmission overdrive)	4078	Deflector (driving pinion oil seal dust)	4859
Control assy (W/S wiper)	17470	Deflector (rear bumper stone)	17845
Core assy (fresh air hot water heater)	18477	Deflector (rear bumper stone)-upper	17808
Countershaft (transmission)	7111	Deflector (rear fender stone)-side	17836-7
Courtesy Lamp Group (Page 231)		Deflector assy (exhaust)	18259
Cover (accelerator pedal dust shield)	9777	Deflector assy (front bumper stone)	17744
Cover (brake adjusting hole)	2092	Deflector assy (radiator grille air)	8310-11
Cover (cylinder front)	6059	Deflector assy (radiator grille air)	8326-27
+Cover (flywheel housing)	6409	Deflector assy (rear bumper stone)	17801
Cover (front bumper stone deflector)	17830	Dial (instrument cluster main)	10887
Cover (fuel tank filler floor opening)	9008	+Dial (transmission gear shift indicator)	15805
Cover (generator regulator)	10560	Diaphragm (fuel pump)	9398
Cover (horn motor)	13809	Diaphragm assy (distributor)	12370
Cover (oil pump drive)	6658	Diaphragm assy (vacuum pump)	99390
Cover (quarter panel wheel opening)	7227968-9	Directional Turn Signal Group (Page 224)	
Cover (quarter panel wheel opening)	7327968-9	Disc (radio knob trim)	18818
Cover (rear axle)	4192	Disc (radio tone and rear seat speaker volume control)	18830
Cover (starter pinion)	6677	Disc (wheel hub cap ornament)	1159
Cover (steering gear housing)	3580	Disc assy (clutch)	7550
+Cover (trans. band access adjusting hole)	7312129	Distributor assy	12100
+Cover (transmission case)-side	7222	Distributor assy-less term. housing & rotor	12127
Cover (trans. extension housing access)	77138	Distributor, Circuit Breaker & Distributor Wiring Group (Page 214)	
Cover (transmission inspection hole)	7518	Dome Lamp Group (Page 232)	
Cover (transmission overdrive governor)	6941	Door (back up lamp)	15513
Cover (transmission overdrive main shaft bearing)	7777	Door (dome lamp)	13788
+Cover (transmission rear oil pump)	77353	Door (front fender headlight)	13045-6
Cover assy (battery box)	5162	Door (license plate lamp)	13566
Cover assy (oil pump)	6637	Door (parking lamp)	13210
Cover assy (oil pump screen)	6615	Door (parking lamp)	13236
Cover assy (rear axle carrier)	4033	Door (parking lamp)	13237
+Cover assy (transmission torus)	7910	Door (rear lamp)	13448-9
Cover and injector assy (W/S washer)	17616	Door (rear lamp)-inner	13443
Cover & screen assy (oil pump)	6622	Door (spotlight lens)	15328
+Cover & seal assy (flywheel housing front dust)	6366	Door assy (dome lamp)	13779
Crankshaft & plugs assy	6303	Dowel (flywheel housing)	6397
Cup (accelerator shaft bracket)	9794	Dowel (flywheel to crankshaft)	6387
Cup (brake master cylinder)	2173	+Dowel (flywheel to torus cover shoulder)	7933
Cup (brake shoe hold down)	2066	Dowel (hood lock)	16929
Cup (differential bearing)	4222	Drive Shaft and Universal Joint Group (Page 41)	
Cup (front wheel bearing)-inner	1202	Drive assy (starter)	11350
Cup (front wheel bearing)-outer	1217	Driver assy (rear window wiper)	17409
Cup (front wheel brake cylinder)	2202	Drum Assy (front brake)	1125
Cup (generator & distributor oil)	10141	Drum assy (rear brake)	1126
Cup (rear axle driving pinion bearing)	4616	+Drum assy (transmission front clutch)	77532
Cup (rear axle driving pinion bearing)	4628	Drum assy (trans. rear clutch)	77187
Cup (rear wheel brake cylinder)	2201	+Drum and pin assy (transmission front)	77536
Cup (steering gear bearing)	3552-53	+Drum and pin assy (transmission rear clutch)	77573
Curb Buffer Group (Page 328)		Duct (fresh air heater blower to dash)	18584
Cushion assy (regulator to dash mounting)	10610	Duct (heater to plenum chamber)	18645
Cutout and Voltage Regulator Chart (Page 201)		Duct (ventilator air)	8721
Cutout and Voltage Regulator Group (Page 200)			
+Cylinder (trans. front clutch band release)	77543	<b>--E--</b>	
Cylinder assy	6009	Eccentric (fuel pump drive camshaft)	6287
Cylinder assy	6011	Elbow (crankcase ventilation)	6762
Cylinder assy (brake master)	2140	Elbow (hot water heater connection)	18599
Cylinder assy (front brake)	2061-2	Elbow (thermostatic choke control tube)	9877
Cylinder assy (rear brake)	2261-2		
Cylinder block	6010		
Cylinder and Engine Supports Group (Page 57)			
Cylinder & keys assy (ignition switch lock)	11582		

+ Used with HYDRA-MATIC transmission

## Alphabetical Index—Continued

Part Name	Basic Part No.	Part Name	Basic Part No.
Elbow (thermostatic choke control tube)	9884	Front Fender Group (Page 258)	
Element (oil filter)	6744	Front Main Bearing Liner Chart (Page 71)	
Emblem (radiator grille)	16607	Front Spring Group (Page 49)	
Emergency Brake & Hand Brake Lever Group (Page 16)		Front Stabilator Group (Page 50)	
End assy (heater plenum chamber)	18627-30	Front Suspension Group (Page 19)	
End assy (spindle connecting rod)	3289	Fuel Pump Group (Page 167)	
Engine Compartment Lamp Group (Page 329)		Fuel Tank Filler Neck Opening Guard Group (Page 329)	
Equalizer (hand brake cable)	2119	Fuel Tank, Fuel Gauge & Oil Gauge Group (Page 164)	
Escutcheon (dome lamp switch)	13770	Fuse (clock)	14526
Exhaust Deflector Group (Page 329)		Fuse (instrument panel lights)	14526
Exhaust Manifolds Group (Page 171)		Fuse (lighting circuit)	14526
Extension (cylinder block drain cock)	8081	Fuse (radio)	14526
Extension (front fender name plate)	16116	Fuse (turn signal)	14526
Extension (radiator grille lower bar)	8230		
Extension (radiator grille lower bar)	8231	<b>- G -</b>	
Extension (radiator grille lower bar)	8376	Gas Filler Lid Lock (Page 329)	
Extension (radiator grille lower bar)	8377	Gasket (air cleaner element)	99622
Extension (rear bumper stone deflector)	17832	Gasket (air cleaner to carburetor)	9654
Extension (rear stone deflector)-outer	17836-7	Gasket (air filter screw)	18675
Extension (rear stone deflector)-outer	17844	Gasket (back up lamp)	15510
Extension assy (radio receiver support)	18951	Gasket (brake master cylinder)	2152
Extension assy (spare tire valve)	18349	Gasket (brake master cylinder filler cap)	2167
Extension, bearing & seal assy (transmission)	7650	Gasket (brake master cylinder outlet)	2154
+ Extension assy (transmission)	7650	Gasket (cable drive W/S wiper)	17556
		Gasket (cable drive W/S wiper motor saddle)	17592
<b>- F -</b>		Gasket (carburetor air horn to throttle body)	9519
Fan & hub assy	8604	Gasket (carb. automatic choke housing to air horn)	9853
Fan Group (Page 153)		Gasket (carb. automatic choke piston housing)	9871
Fender assy	16008-9	Gasket (carburetor body to throttle body)	9516
Fender assy (front)	16005-6	Gasket (carb. float needle seat plug)	9945
Fender assy (rear)	16312-13	Gasket (carburetor float seat)	9569
Ferrule (fuel line)	9242	Gasket (carburetor fuel inlet adapter)	9229
Ferrule (universal joint spider)	7083	Gasket (carburetor main body cover plate)	9985
Field coil assy (generator)	10175	Gasket (carburetor power jet)	9608
Filler (fuel tank)	9034	Gasket (crankshaft rear bearing seal)	6344
Filler assy (W/S wiper blade)	17593	Gasket (cutout regulator)	10623
Filter (fuel pump drain)	9486	Gasket (cylinder front cover)	6020
Filter assy (oil)	6714	Gasket (cylinder head)	6051
Fire extinguisher & tire inflator assy	17940	Gasket (distributor diaphragm vacuum connection)	12320
Fitting (brake master cylinder outlet)	2076	Gasket (driving pinion oil seal)	4671
Fitting (W/S washer)	17615	Gasket (exhaust manifold crossover)	9450
Flange (hot water heater blower dust)	18487	Gasket (exhaust manifold to cylinder block)	9448
Flange (steering column tube)	3511	Gasket (exhaust manifold to muffler inlet pipe)	9453
+ Flange assy (steering column tube)	3509	Gasket (fan)	8638
Flange assy (universal joint)	4851	Gasket (fan rear)	8646
Flasher assy (direction turn signal)	13350	Gasket (floor transmission cover plate)-front	7012116
Flasher & sleeve assy (hand brake signal lamp)	15855	Gasket (floor transmission cover plate)-front	7312116
Float assy (carburetor)	9550	Gasket (floor transmission cover plate)-rear	7012121
Fluid (brake)	19542	Gasket (floor transmission cover plate)-rear	7312121
Fluid (HYDRA-MATIC transmission)	19582	Gasket (floor transmission cover plate)-side	7012122
Fluid (shock absorber)	19541	Gasket (floor transmission cover plate)-side	7312122
Fluid (window regulator)	19545	+ Gasket (flywheel to crankshaft)	6377
Flywheel and Valve Group (Page 72)		+ Gasket (flywheel to torus cover assy)	7945
Flywheel assy	6375	Gasket (fresh air)-valve to dash	18570
Fork (clutch release shaft)	7515	Gasket (fresh air heater blower housing to valve assy)	18570
Fork (gear shifter)	7230-31	Gasket (fresh air heater core housing to dash)	18570
Fork & rail assy (transmission overdrive shift)	7680	Gasket (fresh air heater motor mounting to dash)	18583
Frame assy	5005	Gasket (fresh air heater temperature regulator)	18595
Frame Chart (Page 44)		Gasket (front brake line connector)	2149
Frame Group (Page 42)		Gasket (fuel pump adapter)	9417
Frame (license plate)	18480	Gasket (fuel pump adapter to manifold)	9374
Front Bumper Group (Page 287)			

+ Used with HYDRA-MATIC transmission

## Alphabetical Index—Continued

Part Name	Basic Part No.	Part Name	Basic Part No.
Gasket (fuel pump filter bowl)	9364	Gear (oil pump drive)	6254
Gasket (fuel pump pull rod oil seal)	9408	Gear (oil pump driven)	6610
Gasket (fuel pump valve to upper body)	9367	Gear (oil pump shaft)	6652
Gasket (fuel tank gauge unit flange)	9276	+Gear (rear internal)	77072
Gasket (generator rear end plate)	10119	Gear (speedometer driving)	17285
Gasket (headlamp to fender)	13044	Gear (transmission countershaft)	7113
Gasket (heater core tubes)	18596	Gear (transmission low and reverse)	7100
Gasket (intake manifold)	6521	Gear (transmission main drive)	7017
Gasket (instrument cluster)	10856	Gear (transmission overdrive governor driven)	6922
Gasket (instrument cluster)	10895	Gear (transmission overdrive ring)	7653
Gasket (license plate lamp)	13568	+Gear (transmission rear oil pump drive)	77152
Gasket (oil filter element)	6746	Gear (transmission reverse idler)	7142
Gasket (oil filter cover)	6885	+Gear (transmission reverse internal)	77139
Gasket (oil filter return pipe to oil pan)	6691	Gear assy (oil pump drive idler)	6655
Gasket (oil pan)	6710	Gear assy (speedometer driven)	17322
Gasket (oil pan drain)	6734	Gear assy (steering)	3504
Gasket (oil pan plate assy to sump)	6698	+Gear assy (transmission front drive)	77337
Gasket (oil pump drive cover)	6659	Gear assy (transmission overdrive sun)	7670
Gasket (oil pump flange)	6626	Gear & bushing assy (transmission intermediate)	7102
Gasket (oil pump relief valve)	6669	Gear & case assy (transmission overdrive)	6903
Gasket (parking lamp lens)	13211	+Gear and flange assy (transmission reverse sun)	77170
Gasket (radio antenna)	18898	Gear and shaft assy (speedometer)	17322
Gasket (rear axle carrier)	4035	+Gear and shaft assy (transmission main drive)	77017
Gasket (rear brake line connector bolt)	2149	Gear shift assy (transmission)	7200
Gasket (rear lamp)	13444	Generator assy	10002
Gasket (rear lamp)	13461	Generator Chart (Page 197)	
Gasket (rear lamp water seal)	13453	Generator Group (Page 195)	
Gasket (rear window wiper)	17415	Glass (instrument cluster)	10880
Gasket (rear window wiper)	17416	+Governor assy (transmission)	77390
Gasket (regulator cover to base)	10623	Governor and governor gear assy (trans. overdrive)	6943
Gasket (spark plug)	12410	Grease (distributor)	19575
Gasket (speedometer gear bearing)	17275	Grease (spring lubrication)	19580
Gasket (speedometer)-inner	10856	Grease (wheel bearing)	19585
Gasket (speedometer)-outer	10895	Grease retainer assy (front wheel)	1190
Gasket (steering housing cap)	3595	Grille (radiator)	8150-51
Gasket (steering gear housing cap)	3593-4	Grille (radiator)	8204-05
Gasket (steering gear housing cover)	3581	Grille (radiator)	8376-79
Gasket (trans. bearing retainer)	7051	Grille (radiator center)	8241
+Gasket (transmission case front cover)	77022	Grille (radiator side)	8172-3
+Gasket (transmission case side cover)	7223	Grille (radiator side intermediate)	8378-9
Gasket (trans. extension)	7086	Grommet (air control thru dash)	14605
Gasket (trans. extension housing access cover)	77161	Grommet (antenna lead-in seal)	18912
+Gasket (transmission front pump intake pipe)	77346	Grommet (female clinch)	6931
Gasket (transmission gear shift housing)	7223	Grommet (fuel gauge wire thru floor pan)	14567
+Gasket (transmission oil pan)	77014	Grommet (fuel tank filler)	9080
+Gasket (trans. oil pan drain plug)	77485	Grommet (fuel tank filler neck)	9072
Gasket (transmission overdrive housing adapter)	7661	Grommet (hand brake cable opening in dash)	7201695
Gasket (transmission overdrive main shaft cover)	7778	Grommet (hand brake cable thru dash panel)	14602-3
Gasket (transmission overdrive rail switch)	6932	Grommet (headlamp wire)	13091
+Gasket (transmission pressure regulator to case)	77382	Grommet (headlamp wiring thru air deflector)	14615
+Gasket (transmission rear bearing retainer)	7086	Grommet (headlight dimmer switch)	13090-92
Gasket (trans. to flywheel housing)	7622	Grommet (hood catch cable)	14605
Gasket (vacuum antenna)	18898	Grommet (hood release cable control frt. air defl.)	14605
Gasket (vacuum pump cover plate)	99367	Grommet (hood release cable on dash)	14605
Gasket (water outlet connection)	8255	Grommet (ignition wiring and clip)	12297
Gasket (water pump)	8507-08	Grommet (license lamp wiring)	14617
Gasket (wheel bearing retainer)	2245	Grommet (male clinch)	6930
Gasket (W/S wiper cable drive)	17523	Grommet (overdrive cable dash)	14605
Gasket assy (carburetor air horn to throttle body)	9519	Grommet (W/S wiper hose)	14602
Gauge (oil)-engine unit	9278	Grommet (wiring)	14603
Gauge assy (fuel tank unit)	9275	Grommet (wiring thru dash & floor pan)	14603
Gear (camshaft)	6256	Guard (frt. cross member)-"V" shaped	55027
Gear (crankshaft)	6306	Guard (fuel tank filler neck opening)	18296
Gear (differential side)	4236	Guard assy (front bumper)	17996-7
+Gear (front unit drive)	77078	Guard assy (rear bumper)	17984-5
		Guard assy (rear bumper license plate)	17804

+ Used with HYDRA-MATIC transmission

## Alphabetical Index—Continued

Part Name	Basic Part No.	Part Name	Basic Part No.
Guide (hood lock spring)	16927	Housing assy (cable drive W/S wiper pivot shaft)	17554
Guide (hood roller)	16652-3	Housing assy (cable drive W/S wiper pivot shaft)	17555
Guide (transmission overdrive shift rail)	7696	Housing assy (distributor terminal)	12106
Gusset (frt. cross member to frame)	5123	Housing assy (flywheel)	6392
<b>-H-</b>			
Hair (fuel pump body curled)	9486	Housing assy (rear axle)	4010
Hand Brake Signal Group (Page 329)		Housing assy (transmission gear shift)	7201
Handle & shank assy (turn signal switch)	13305	*Housing assy (trans. gear shift indicator lamp)	15800
Hanger (front bumper inner)	17766-67	Housing assy (transmission overdrive)	7650
Hanger (front bumper outer)	17754-5	Housing & bushing assy (steering gear)	3548
Hanger (rear bumper inner)	17786-7	Housing & core (hot water fresh air heater)	18478
Hanger (rear bumper outer)	17795-6	Housing and core assy (fresh air hot water heater)	18506
Hanger (rear spring)	5770	Housing & plugs assy (carb. automatic choke)	9849
Hanger (rear spring)	5775	Housing & thermostat assy (carb. automatic choke)	9848
Hanger (rear spring shackle)	5610-11	Housing & tube seat assy (rear brake cylinder)	2135-36
Hanger assy (fuel tank front)	9066	Hub (clutch release bearing)	7561
Head (cylinder)	6049-50	Hub (intermediate & high clutch)	7105
Head (starter drive)	11381	*Hub (transmission rear clutch)	77579
Headlamp assy	13002	Hub assy (fan)	8603
Headlamp Group (Page 220)		Hub and cup assy (wheel front)	1104
Heater assy (fresh air hot water)	18478	Hub & drum assy (front)	1105
Heater assy (fresh air hot water)	18455	Hydraulic brake fluid	19542
Hinge assy (hood)	16800	HYDRA-MATIC Transmission Group (Page 95)	
Hinge & lever assy (accelerator pedal)	9765	HYDRA-MATIC Transmission Chart (Page 96)	
Holder (starter brush)	11061	<b>-I-</b>	
Hood Group (Page 267)		Ignition Coil Group (Page 213)	
Hood assy	16612	Ignition Switch Group (Page 213)	
Hook (hood auxiliary catch)	16896	Impact bar (front bumper center lower front)	17752
Hook assy (hood auxiliary catch)	16892	Impeller (water pump)	8512
Horn assy	13832-33	Indicator assy (charge)	10850
Horn & bracket assy	13801-2	Indicator assy (fuel level)	9280
Horn & plugs assy (carburetor air)	9524	Indicator assy (oil level)	6750
Horn Group (Page 234)		Indicator assy (oil pressure)	9273
Hose (battery tray drain)	10719	Indicator assy (temperature)	10883
Hose (fresh air heater defroster)	18556	*Indicator assy (transmission oil level)	77019
Hose (fresh air hot water heater)	18472	Inhibitor (rust)	19546
Hose (fresh air hot water heater inlet)	18648	Insert (trans. intermediate & high clutch hub)	7116
Hose (fresh air hot water heater temperature valve to heater core)	18551	Insert (valve seat)	6057
Hose (fuel tank filler)	9047	Insert (wheel hub cap)	1138
Hose (fuel tank filler air relief)	9170	Insert assy (rear spring)	5586
Hose (heater inlet)	18472	Insert assy (W/S wiper blade)	17593
Hose (heater inlet)	18648	Instrument Panel Indicators Group (Page 204)	
Hose (radiator lower)	8286	Insulation (generator terminal)	10202
Hose (radiator upper)	8260	Insulation (starter brush holder)	11062
Hose (radio antenna)	18931	Insulator (current limiter contact post)	10522
Hose (rear window wiper)	17412	Insulator (current limiter unit contact post)	10524
Hose (rear window wiper)	17413	Insulator (distributor primary terminal)	12234
Hose (W/S washer side of pump to tie)	17580	Insulator (distributor to spark plug wire)	12113
Hose (W/S washer tee to nozzle)	17580	Insulator (front shock absorber)	18198
Hose (W/S wiper)	17543	Insulator (front suspension coil spring)	5414-15
Hose (W/S wiper motor to vacuum booster)	17522	Insulator (generator brush holder rivet)	10048
Hose assy (front brake)	2079	Insulator (generator end plate)	10208
Hose assy (fuel pump to fuel line)	9288	Insulator (generator frame field terminal)	10208
Hose assy (rear brake)	2078	Insulator (generator frame terminal screw)	10206
Hot Water Heater Group (Page 330)		Insulator (horn wire terminal)	3635
*Housing (flywheel)	6394	Insulator (radio antenna)	18897
Housing (front brake cylinder)	2190-91	Insulator (spark plug)	12425
Housing (instrument and control cluster)	10841	Insulator (stabilator bar to frame)	5484
Housing (roadlamp grille)	8206-07	Insulator (starter brush holder rivet)	10044
Housing (transmission gear shift)	7222	Insulator (starter terminal)	11107
		Insulator (steering column to dash cover plate)	7301788
		Insulator (transmission gear shift lever)	7246
		Insulator (vacuum antenna)	18897

\* Used with HYDRA-MATIC transmission



## Alphabetical Index—Continued

Part Name	Basic Part No.	Part Name	Basic Part No.
+ Insulator assy (engine front support rebound)-lower	6039	Kit (generator brush)	10043
+ Insulator assy (engine front support)-upper	6038	Kit (hand brake signal lamp installation)	18159
Intake Manifold Group (Page 74)		Kit (hub cap medallion)	1141
Intermediate Main Bearing Liner Chart (Page 71)		Kit (non glare rear view mirror)	18400
<b>- J -</b>			
Jack assy (bumper)	17080	Kit (oil filter element)	6731
Jar (W/S washer)	17618	Kit (oil pan gasket)	6781
Jet (carburetor main metering)	9533	Kit (quarter wheel cover moulding)	18326
Jet assy (carburetor idling)	9542	Kit (reading and vanity light)	18295
Jet assy (W/S washer)	17666	Kit (rear brake lining)	2222
Jewel and housing assy (instrument cluster signal lamp)	13584	Kit (rear brake shoe & lining)	2200
Jumper wire assy (heater switch)	14309	Kit (rear door safety lock)	18333
<b>- K -</b>			
Key (glove compartment & rear deck compt. lock)	18306	Kit (rear fender shield)	18973
Key (steering & ignition)	3685	Kit (rear shock absorber bushing)	18080
Key (steering wheel)	3609	Kit (rear spring rear shackle and front bolt)	5630
+ Key (transmission front pump drive woodruff)	77347	Kit (rear spring service leaf)	5560
Key (trans. reverse clutch stationary cone)	77594	Kit (rear view mirror installation)	18402
Key (valve spring retainer)	6518	Kit (rear wheel brake cylinder repair)	2128
Kit (accelerator pedal installation)	9735	Kit (rear window wiper installation)	18387
Kit (automatic W/S washer)	18293	Kit (roadlamp installation)	18207
Kit (back up lamp)	18275	Kit (rocker panel moulding installation)	18243
Kit (back up lamp installation)	18274	Kit (spark plug and coil high tension wire)	12259
Kit (brake lining)	2007	Kit (spark plug insulator installation)	18344
Kit (brake master cylinder repair)	2004	Kit (spindle bolt and bushing)	3111
Kit (brake or clutch pedal extension)	2452	Kit (spotlight bracket installation)	18154-5
Kit (brake spring repair)	22009	Kit (starter brush)	11057
Kit (carburetor float and float spring)	99525	Kit (steering idler arm)	3352
Kit (carburetor gasket)	9502	Kit (steering spindle connecting rod end)	3270
Kit (carburetor metering repair)	9995	Kit (thermostat)	18368
Kit (carburetor repair)	9590	Kit (thermostat and gasket)	8570
Kit (caulking strip)	19560	Kit (transmission and extension gasket)	7153
Kit (cigar lighter element)	7004603	+ Kit (trans. clutch piston seal and expander)	77535
Kit (c/shaft conversion)	6303	+ Kit (trans. front pump screws and washers)	77330
Kit (curb buffer moulding installation)	18243	+ Kit (transmission governor drive flange)	77388
Kit (cylinder head gasket)	6079	Kit (trans. manual control shaft seal and washer)	77769
Kit (distributor breaker arm & brkt. assy)	12171	Kit (trans. pressure regulator plugs and gaskets)	77383
Kit (distributor governor weight spring)	12322	+ Kit (transmission rear oil pump driven gear)	77360
Kit (door lock and sleeve)	7221942-3	+ Kit (transmission rear servo check valve)	77448
Kit (emergency utility lamp and case)	15550	Kit (trans. rear servo compensator piston & spring)	77475
Kit (engine compartment lamp)	18375	Kit (trans. reverse clutch piston seals)	77167
Kit (engine overhaul gasket)	6008	+ Kit (transmission throttle shaft repair)	77211
Kit (exhaust deflector)	18259	Kit (universal joint)	7039
Kit (exhaust manifold gasket)	9433	Kit (universal W/S wiper arm)	17464
Kit (frame conversion)	6054	Kit (visor vanity mirror)	18208
Kit (front brake lining)	2007	Kit (water pump repair)	8591
Kit (front brake shoe and lining)	2001	Kit (W/S wiper arm and blade display)	17528
Kit (front shock absorber bushing)	18045	Knob (automatic temperature regulator control)	18529
Kit (frt. suspension lower arm to spindle support)	3050	Knob (rear window wiper control)	17408
Kit (front suspension lower inner)	3048	Knob (roadlamp switch)	18817
Kit (frt. suspension upper arm to spindle support)	3049	Knob (trans. gear shift lever)	7213
Kit (front suspension upper inner shaft)	3047	Knob (vacuum antenna control valve)	18911
Kit (front wheel brake cylinder repair)	2221	Knob assy (fresh air hot water heater blower switch and antenna control)	18513
Kit (front wheel spindle pin)	3111	Knob assy (fresh air hot water heater regulator control)	18519
Kit (fuel pump repair)	9349	Knob assy (radio tuning control)	18824
Kit (fuel pump strainer)	99360	Knob assy (radio volume control & roadlamp switch)	18817
Kit (fuse)	14527	Knob assy (W/S wiper control)	17513
Kit (gas filler lid lock installation)	18168	Knob and insert assy (headlamp control switch)	11661
		Knuckle (universal joint)	4841

+ Used with HYDRA-MATIC transmission

## Alphabetical Index—Continued

Part Name	Basic Part No.	Part Name	Basic Part No.
<b>-L-</b>		Lock set assy (ignition & door lock cylinder)	3687
Lamp (engine compartment)	15702	Lubriplate	19856
Lamp assy (back up)	15500	Luggage Compartment Lamp (Page 229)	
Lamp assy (courtesy)	13707	<b>-M-</b>	
Lamp assy (dome)	13776	Manifold (exhaust)	9430-31
Lamp assy (dome)	13777	Manifold assy (intake)	6519
Lamp assy (front compartment courtesy)	13706	Maplight assy (instrument control panel)	15650
Lamp assy (hand brake signal)	15850	Map Light Group (Page 233)	
Lamp assy (license plate)	13550	Mask (instrument cluster)	10890
Lamp assy (luggage compartment)	13506	Master cylinder assy (brake)	2140
Lamp assy (map)	13756	Medallion (front fender)	16724
Lamp assy (parking)	13200-01	Medallion (wheel hub cap)	1141
Lamp assy (rear)	13404-05	Member assy (frame front cross)	5019
Lamp assy (road)	15200	Member assy (frame intermediate cross)	5029
Lamp assy (utility)	15550	Member assy (frame rear cross)	5035
Latch assy (hood)	8162	Mirror (visor vanity)	13757
Lead-in assy (radio antenna)	18812	Mirror assy (outside rear view)	18402-03
Lens (back up lamp)	15514	Mirror assy (rear view)	17682
Lens (courtesy lamp)	13731	Mirror & bracket assy (rear view)	17700
Lens (dome lamp)	13783	Miscellaneous Kit Group (Page 357)	
Lens (license plate lamp)	13564	Motor assy (fresh air heater blower)	18527
Lens (map lamp)	13761	Motor assy (rear window wiper)	17404
Lens (parking lamp)	13208-09	Motor assy (windshield wiper)	17508
Lens (rear lamp)	13450	Moulding (control panel steering column)	10872
Lens assy (hand brake signal lamp)	15856	Moulding (front fender)	16003-4
Lens & bezel assy (courtesy lamp)	13723	Moulding (front fender lower edge curb buffer)	16210
Lens & retainer (luggage compartment lamp)	13547	Moulding (heater control frame plate)	18498
Lens & rim assy (courtesy lamp)	13716	Moulding (rocker panel curb buffer)	7210176-7
Lever (hand brake equalizer)	2532	Moulding (front fender lower edge curb buffer)	16211
Lever (transmission gear shift)	7210	Moulding assy (front fender)	16196-7
*Lever (trans. inside throttle valve control)	77284	Moulding & stud assy (fender side)	16024-5
Lever (transmission overdrive control)	7689	Mounting assy (heater blower motor)	18565
*Lever (transmission outer shift)	7285	Muffler assy	5230
*Lever (transmission rear band actuating)	77516	Muffler Group (Page 47)	
*Lever (transmission throttle control outer)	7919	<b>-N-</b>	
Lever assy (carburetor choke shaft)	9846	Needle (carburetor accelerator pump discharge)	9902
Lever assy (low & reverse shift)	7290	Needle (carburetor idle adjusting)	9541
Lever assy (parking brake operating)	2103-04	Needle, seat, gasket & wire clip assy (carb. float)	9564
*Lever assy (trans. inside detent control)	77234	Nozzle and pivot mounting spacer (W/S washer)	17665
Lever assy (transmission intermediate & high shift)	7285	Nozzle assy (fresh air hot water heater defroster)	18490
Lever & insulator assy (trans. gear shift)	7302-03	Nozzle assy (hot water heater defroster)	18491
Lever & link assy (carburetor choke thermostat)	9838	Numerical List of 15000 Miscellaneous Accessories Group (Page 256)	
Lever & shaft assy (carb throttle)	9927	Numerical List of 18000 Miscellaneous Accessories Group (Page 302)	
Lever, ball & insulator assy	7202	Numerical List of 19000 Miscellaneous Accessories Group (Page 308)	
License Plate Frame Group (Page 342)		Numerical List of Chassis Five Digit Part Numbers (Page 310)	
Lid (battery cover inspection)	5167	Numerical List of Special Bolts, Pins, Washers, etc. (Page 324)	
Lighting Switch Group (Page 213)		Numerical List of Standard Parts (Page 319)	
Line assy (fuel)	9282	Nut (accelerator shaft to pedal rod adjusting)	9756
Liner (rear spring clamp)	5334	Nut (brake adjusting screw pilot)	2047
Lining (front brake)	2021-2	Nut (drive shaft to rear axle)	6212
Lining (rear brake)	2285	Nut (fan hub & spindle double)	8642
Link (brake shoe connecting)	2042	Nut (fuel pump filler bowl bail)	9167
Link (clutch pedal retracting spring)	7592	Nut (hand brake equalizer lever)	2091
Link (fuel pump)	9381		
Link (vacuum pump rocker arm)-RH	99380		
Link (vacuum pump rocker arm)-LH	99381		
Link assy (brake master cylinder)	2143		
Link assy (carburetor accelerator pump)	9526		
Link & bracket assy (hood hinge)	16796-7		
*Lock (trans. reverse anchor support bolt)	77135		
Locknut assy (steering thrust screw)	3539		
Lock set assy (glove compartment & rear deck)	3689		
* Used with HYDRA-MATIC transmission			

## Alphabetical Index—Continued

Part Name	Basic Part No.	Part Name	Basic Part No.
Nut (mirror to visor)	13816	†Pin (transmission rear band actuating lever)	77521
Nut (oil filter tube)	2133	†Pin (transmission rear clutch spring guide)	77575
Nut (rear spring clip)	5333	Pin (trans. reverse blocker piston stop)	77164
†Nut (transmission mainshaft)	7923	Pin assy (rear spring)	5780
Nut (vacuum antenna dome)	18865	Pinion (differential)	4215
Nut (wheel bolt)	1012	Pinion and barrel assy (starter drive)	11367
<b>—O—</b>			
†Oil (Hydro-Matic transmission)	19582	Pinion & gear (rear axle driving)	4209
Oil Filler and Crankcase Ventilation Group (Page 82)		Pipe (muffler outlet)	5255
Oil Filter Group (Page 79)		Pipe (oil filler)	6765
Oil Pan Group (Page 78)		†Pipe (transmission front oil pump delivery)	77348
Oil Pump Group (Page 75)		†Pipe (transmission governor oil supply)	77401
Oil seal (fuel pump diaphragm)	9469	†Pipe (transmission servo oil transfer)	77426
†Oil seal assy (transmission extension rear)	7657	Pipe assy (exhaust crossover)	5267
Oiler (distributor base)	12135	Pipe assy (flexible conn. line to fuel pump inlet)	9283
Ornament (front fender side)	16188-9	Pipe assy (front brake)	2263
Ornament (hood front and luggage compartment door)	16637	Pipe assy (fuel pump to carburetor)	9369
Ornament (hood lower front)	8216	Pipe assy (master cylinder to brake)	2264-5
Ornament assy (hood)-top center	16850	Pipe assy (muffler inlet)	5246
<b>—P—</b>			
Packing (automatic choke)	9845	Pipe assy (rear brake)	2267-68
Packing (carburetor accelerator pump operating rod)	9535	†Pipe assy (transmission front oil pump inlet)	77321
Packing (carburetor automatic choke)	9845	†Pipe assy (transmission rear oil pump discharge)	77366
Packing (crankshaft front)	6707	Pipe and hose assy (fuel tank filler)	9032
Packing (crankshaft front)	6700	Pipe filler assy (fuel tank)	9034
Packing (crankshaft rear)	6701	Piston	6110
Pad (back up lamp to car body)	15533	Piston (carburetor choke)	9840
Pad (brake & clutch pedal)	2457	Piston (front wheel brake cylinder)	2198
Pad (front fender apron & radiator support)	16186	Piston (rear wheel brake cylinder)	2197
Pad (hood)	16740	†Piston (transmission front band release)	77540
Pad (rear lamp mounting)	13420	†Piston (transmission front clutch cylinder)	77531
†Pan assy (trans. control linkage splash)	7770	Piston (trans. parking blocker)	77328
†Pan assy (transmission oil)	77011	†Piston (transmission rear clutch cylinder)	77572
Panel (front bumper stone deflector ornament)	17818	†Piston (trans. rear servo compensator)	77475
Panel (front bumper stone deflector ornament)	17819	Piston (transmission reverse)	77163
Panel (front bumper stone deflector ornament end)	17824-5	Piston (trans. reverse shifter blocker)	77294
Panel (radiator air deflector)	8308	Piston assy (brake master cylinder)	2169
Panel assy (hood)	16612	Piston assy (carb. accel. pump)	9631
Parking Lamp Group (Page 222)		Piston assy (carburetor automatic choke)	99523
Pawl (transmission overdrive stationary gear)	7690	†Piston assy (transmission front servo)	77410
Pawl (transmission parking)	77311	Piston and Connecting Rod Group (Page 65)	
†Pawl (transmission reverse gear anchor)	77137	†Piston & stem assy (trans. rear service booster)	77470
Pawl (turn signal switch)	13309	†Piston & stem assy (trans. rear servo accumulator)	77460
Pedal & bushing assy (brake)	2452	Piston & stem assy (carburetor economizer)	9904
Pedal & bushing assy (clutch)	7520	Plate (brake master cylinder piston stop)	2188
Pedal, pad & clip assy (accelerator)	9735	Plate (brake shoe anchor pin guide)	2028
Pin (brake pedal clevis)	7533	Plate (camshaft thrust)	6269
Pin (brake shoe anchor)	2027	Plate (carburetor automatic choke housing)	9844
Pin (brake shoe hold down spring)	2069	Plate (carb. choke)	9545
Pin (carburetor choke plate stop)	9946	Plate (carburetor main body cover)	9984
Pin (carburetor float hinge)	9558	Plate (carburetor throttle)	9585
Pin (front wheel spindle)	3115	†Plate (dash pedal opening)	7311126
Pin (fuel and vacuum pump rocker arm)	9378	Plate (engine rear)	7009
Pin (gear shift interlock)	7235	Plate (frame front cross member lower reinforcement)	5818-19
Pin (hand brake handle locking)	2819	Plate (frame rear cross member lower reinforcement)	5822-23
Pin (hand brake lever)	2859	Plate (fresh air hot water heater control name)	18475
Pin (oil pump shaft gear)	6661	Plate (front fender name)	16079
Pin (piston)	6135	Plate (front shock absorber mounting)	18072
Pin (starter drive pinion)	11365	Plate (fuel pump valve)	9361
		Plate (generator drive end)	10139
		Plate (heater outlet)-front	18585
		Plate (heater outlet)-rear	18586
		Plate (radiator air deflector cover)	8346
		Plate (rear spring center bolt)	5708
		Plate (rear view mirror)	17710

† Used with HYDRA-MATIC transmission

## Alphabetical Index—Continued

Part Name	Basic Part No.	Part Name	Basic Part No.
Plate (regulator hinge spring reinforcement)	10568	*Plunger (trans. rear servo check valve)	77469
Plate (starter drive spring anchor)	11372	*Plunger & bushing assy (trans. governor high speed)	77391
Plate (steering column to dash cover)	7001698	Point (current limiter contact post)	10576
Plate (steering column to dash cover)	7001699	Point (cutout unit main contact)	10535
Plate (steering column to dash cover)	7301728	Point (regulator contact)	10653
Plate (steering column to dash cover)	7301782	Point & post (cutout contact)	10541
Plate (steering column to dash cover)-lower	7301698	Point & post assy (current limiter contact)	10565
Plate (steering column to dash cover)-upper	7301699	Point and rivet assy (cutout unit auxiliary contact)	10617
Plate (steering gear housing end)	3568	Point and screw assy (cutout unit main contact)	10609-16
*Plate (transmission center bearing cap lock)	77031	Point set (distributor)	12171
*Plate (transmission clutch driven)	77551	Pointer (timing)	6023
*Plate (transmission cover filler hole)	7312133	Polish (body)	19530
*Plate (transmission cover filler hole)-curved	7212133	Polish (body porcelainize)	19529
*Plate (trans. oil pump inlet pipe bolt)	77320	Primary assy (distributor terminal)	12216
*Plate (transmission valve body spacer)	77604	Prop (roadlamp mounting)	15209
Plate (vacuum pump cover)	99355	Pulley (generator)	10130
Plate (vacuum pump valve retainer)	99361	Pulley (water pump)	8509
Plate assy (distributor breaker)	12151	*Pulley (water pump)-LH	8552
Plate assy (distributor breaker sub)	12242	*Pulley (water pump)-RH	8545
*Plate assy (engine rear support)	6054	Pulley and bracket assy (fan)	8625
Plate assy (front brake backing)	2012	Pulley assy (hand brake cable)	2804
Plate assy (instrument cluster back)	10842	Pump assembly (fuel)	9350
Plate assy (rear brake backing)	2211-1	Pump assy (oil)-less screen and cover assy	6621
Plate assy (rear spring clip)	5796-7	Pump assy (tire)	17052
Plate assy (starter rear end)	11130	*Pump assy (transmission front oil)	77331
Plate assy (steering gear housing end)	3597	*Pump assy (transmission rear oil)	77351
*Plate assy (transmission clutch drive)	77563	Pump assy (water)	8501-2
Plate assy (turn signal switch)	13304	Pump assy (water)-less pulley	88502-3
Plate & brush assy (generator end)	10050	Pump assy (w/S washer)	17664
Plate & cover assy (clutch pressure)	7563		
Plate & spring assy (w/S wiper)	17450	<b>- R -</b>	
Plate & stone deflector assy (rear spring clip)	5796-7	Radiator assy	8005
*Plate and stud assy (accelerator bell crank)	99765	Radiator Group (Page 137)	
Plate & trough assy (transmission overdrive cover)	7665	Radiator Grille Group (Page 138)	
Plate, bushing & brush holders assy (starter brush end)	11049	Radiator Stop Leak	19558
Plenum chamber assy (heater)	18471	Radio assy-less antenna	18805
Plug (battery filler)	10720	Radio Group (Page 343)	
Plug (brake master cylinder bore)	2161	Reading and Vanity Light Group (Page 346)	
Plug (carburetor float needle seat)	9944	Rear Axle Chart (Page 37)	
Plug (carburetor main body passage)	9523	Rear Axle Group (Page 34)	
Plug (carburetor passage)	9588	Rear Bumper Group (Page 292)	
Plug (carburetor throttle)	9941	Rear Door Safety Lock Group (Page 346)	
Plug (carburetor throttle boss)	9941	Rear Fender Shield Group (Page 347)	
Plug (cylinder block oil pipe)	6026	Rear Fender Group (Page 264)	
Plug (cylinder oil pipe)-rear	6026	Rear Lamp Group (Page 226)	
Plug (defroster opening end)	18526	Rear License Lamp Group (Page 230)	
Plug (distributor base)	12138	Rear Main Bearing Liner Chart (Page 70)	
Plug (distributor passage)	9517	Rear Seat Speaker Group (Page 348)	
Plug (generator brush end plate oil)	10146	Rear Shock Absorber Stud Chart (Page 300)	
Plug (oil pan drain)	6730	Rear Spring Clip Chart (Page 53)	
Plug (oil pump relief valve)	6672	Rear Springs, Hangers and Clips Group (Page 51)	
Plug (steering gear filler)	3538	Rear Spring Inner Clamp Chart (Page 55)	
Plug (steering gear worm cover)	3582	Rear Spring Outer Clamp Chart (Page 54)	
*Plug (transmission governor sleeve)	77400	Rear View Mirror Group (Page 286)	
*Plug (trans. throttle valve pressure regulator)	77354	Rear View Mirror (Outside) Group (Page 348)	
*Plug (transmission torus cover)	7920	Rear Wheel Cover Group (Page 266)	
Plug assy (spark)	12405	Rear Window Wiper Group (Page 278 and 348)	
*Plug assy (trans. oil pan drain)	77483	Reflector (rear lamp)	13437
*Plug assy (transmission pressure regulator valve)	77383	Regulator assy (generator)	10505
Plunger (cylinder block oil relief valve)	6663		
Plunger (front oil relief valve)	6663		
Plunger (oil pump relief valve)	6674		
Plunger (trans. manual detent)	77607		

\* Used with HYDRA-MATIC transmission

## Alphabetical Index—Continued

Part Name	Basic Part No.	Part Name	Basic Part No.
Reinforcement (front bumper center impact bar lower)	17859	Rim (front fender headlamp)	13045-6
Reinforcement (rear bumper center bar)	17858	Rim (license plate lamp)	13566
Reinforcement (rear fender to body)	16318-19	Rim (rear lamp)	13448-9
Reinforcement & brkt. assy (road & parking lamps)	15262-3	Rim (roadlamp)	15214
Relay assy (starter switch)	11450	Rim assy (spotlight)	15328
Relay assy (transmission overdrive)	6915	Ring (camshaft gear locking)	6258
Relay & bracket assy (horn)	13853	Ring (carb. accel. pump piston operating rod ret.)	9987
Reservoir and injector assy (W/S washer)	17574	Ring (generator bearing stop)	10163
Resistor (heater switch)	18591	Ring (headlamp bulb retaining)	13018
Resistor (regulator field)	10570	Ring (headlamp wiring grommet)	13094
Resistor (regulator field absorbing)	10594	Ring (horn)	3624
Resonator and inlet pipe assy (muffler)	5246	Ring (roadlamp retainer)	15214
Retainer (back up lamp lens)	15522	Ring (roadlamp unit retainer)	15229
Retainer (brake master cylinder return spring)	2185	Ring (starter drive screw)	11371
Retainer (carburetor fast idle cam)	9553	✦Ring (transmission clutches sleeve assy oil seal)	77432
Retainer (carburetor filter screen)	99528	✦Ring (transmission driven torus retaining)	7927
Retainer (clutch & brake pedal)	7547	✦Ring (transmission front oil pump seal)	77340
Retainer (clutch pedal retracting spring)	7540	✦Ring (trans. front servo band release piston oil)	77397
Retainer (crankshaft rear bearing oil)	6335	✦Ring (transmission front servo piston oil seal)	77430
Retainer (diaphragm rod)	12388	✦Ring (transmission governor oil collector)	77431
Retainer (distributor breaker plate)	12146	✦Ring (transmission governor oil seal)	77428
Retainer (distributor cam)	12177	Ring (transmission overdrive cover plate)	7666
Retainer (distributor diaphragm rod)	12388	Ring (trans. overdrive governor driven gear ret.)	6929
Retainer (dome lamp lens)	13784	Ring (trans. overdrive pinion cage to main shaft)	7672
Retainer (front spring shim)	5363	Ring (trans. overdrive ring gear snap)	7654
Retainer (fuel pump body curled hair)	9434	✦Ring (transmission rear clutch cylinder retaining)	77584
Retainer (fuel pump diaphragm spring)	9371	✦Ring (trans. rear servo booster piston oil seal)	77434
Retainer (fuel pump oil seal)	9468	✦Ring (trans. rear servo booster piston oil seal)	77435
Retainer (hood front ornament)	16644	✦Ring (trans. rear servo compensator oil seal)	77429
Retainer (ignition wires)	12271	Ring (transmission synchronizer blocking)	7107
Retainer (parking lamp lens)	13439	Ring & gear plate assy (transmission overdrive balk)	7662
Retainer (piston pin)	6140	Ring gear and pinion (rear axle)	4209
Retainer (quarter panel wheel cover seal)	7227996-7	Ring set (piston)	6149
Retainer (ratchet bar locking spring)	2786	Rivet (distributor cap clamps)	12145
Retainer (rear brake emergency lever pin)	2106	Rivet (generator & starter locating)	10088
Retainer (rear lamp grommet wiring)	14608	Rivet (starter & generator brush end plate)	11069
Retainer (rear stone deflector center)	17879	Roadlamp assy	15200
Retainer (rear stone deflector outer)	17881	Roadlamp Group (Page 348)	
Retainer (rear wheel bearing)	1180	✦Rod (accelerator shaft and bracket to bell crank)	9785
Retainer (rear wheel bearing)	2240	Rod (accelerator shaft to pedal)	9727
Retainer (roadlamp ring)	15207	Rod (automatic choke thermostat)	9869
Retainer (rocker panel curb buffer moulding)	7210198	✦Rod (carburetor automatic choke thermostat)	9869
Retainer (steering column opening sealer)	7001654	Rod (carburetor fast idle)	9598
Retainer (steering column opening sealer)	7301654	Rod assy (brake pedal to master cylinder)	2458
✦Retainer (transmission fourth to third speed down shift valve)	77232	Rod assy (accelerator to carburetor)	9747
✦Retainer (transmission front servo release spring)	77418	Rod assy (carburetor accel. pump piston operating)	9531
Retainer (trans. gear shift selector spring)	7308	Rod assy (clutch pedal release arm)	7530
Retainer (transmission main drive gear bearing)	7050	Rod assy (connecting)	6200
✦Retainer (transmission manual valve detent ball)	77613	Rod assy (fuel pump push)	9400
Retainer (transmission overdrive free wheel cam)	7676	Rod (hand brake equalizer)	2529
✦Retainer (transmission pilot bearing)	7942	✦Rod assy (bell crank to accelerator)	9784
✦Retainer (transmission rear servo spring)	77452	Rod assy (transmission high & intermediate gear shift)	7325
Retainer (trans. reverse clutch piston spring)	77598	Rod assy (transmission low & reverse gear shift)	7327
✦Retainer (transmission torus check valve)	7921	Rod & ball stud assy (steering linkage tie)	3281
Retainer (valve spring)	6514,16	Rod and bracket assy (accelerator "Z")	9725
Retainer (vacuum pump screen)	99366	Rod & cylinder assy (radio antenna)	18850
Retainer (water pump bearing)	8576	✦Rod, nut and clevis assy (bell crank to valve shift lever)	7442
Retainer assy (antenna through dash)	14608	✦Rod, nut and clevis assy (manual shift)	7325
Retainer assy (flywheel to friction disc)	6445	Roller (hood guide)	16647
Retainer assy (speed grip nut)	55052	✦Roller (transmission reverse shifter crank)	77299
Retainer assy (trans. detent plunger)	77285	Roller assy (steering gear worm bearing)	3571
Retainer assy (wiring thru dash)	14608	Rotor assy (distributor)	12200
		Rubber Cement	19552
		Rust inhibitor (radiator)	19546

✦ Used with HYDRA-MATIC transmission

## Alphabetical Index—Continued

Part Name	Basic Part No.	Part Name	Basic Part No.
<b>—S—</b>			
Saddle assy (steering column "U" bolt)	3678	Seal (trans. control linkage splash pan)	7772
Screen (carburetor filter)	99526	✦Seal (transmission cover filler hole)	7312179
Screen (vacuum pump)	99368	✦Seal (transmission front cover oil)	77334
Screen (ventilating air conductor)	8716	Seal (transmission main drive gear oil)	7052
Screen and retainer assy (carb. filter)	99522	✦Seal (trans. pressure regulator to case)	77355
Screen assy (fuel pump filter bowl)	9365	Seal (transmission overdrive pawl operating rod)	7693
Screen assy (oil pump)	6623	Seal (universal joint grease)	7078
✦Screen assy (transmission oil pump intake)	77016	Seal (ventilating fresh air duct joint)	8721
Screw (brake adjusting)	2041	Seal assy (rear axle driving pinion oil)	4676
Screw (brake wheel cylinder bleeder)	2208	Seal assy (rear wheel bearing oil)	1177
Screw (carburetor throttle & choke plate)	9586	Seal assy (steering gear housing oil)	3591
Screw (current limiter armature adjusting)	10523	Seal assy (transmission main shaft oil)	7657
Screw (generator pole piece)	10044	Seal assy (transmission shifter shaft oil)	7688
Screw (generator terminal)	10211	Seal assy (water pump)	8564
Screw (headlamp adjusting)	13032	✦Seal and sleeve assy (water pump)	8564
Screw (mirror to visor)	13814	Sealer (compound)	19554
Screw (oil filter cover)	6741	Sealer (rear fender reinforcement to body front)	16381
Screw (parking lamp lens retaining)	13247	Sealer (radiator grille air deflector)	8344
Screw (starter drive head spring)	11377-82	Sealer (steering column opening weather)	3513
Screw (starter pole piece)	10044	Seat (front shock absorber insulator)	18031
Screw (steering sector thrust)	3577	Seat (fuel pump filter bowl)	9388
✦Screw (transmission rear internal gear to rear drum)	77077	Seat (trans. front servo rear pump tube)	77408
Screw (vacuum pump)	99368	Seat (vacuum pump diaphragm spring)	99359
Screw & lockwasher (heater to dash)	18654	Service Brakes Group (Page 3)	
✦Screw and washer assy (detent retainer to outer valve body)	77632	Service Brake Controls Group (Page 14)	
✦Screw and washer assy (front valve body cover plate to body)	77127	Shaft (clutch release bearing)	7510
✦Screw and washer assy (front valve body to inner)	77126	Shaft (clutch release equalizer)	7503
✦Screw and washer assy (inner valve body rear cover)	77631	Shaft (differential pinion)	4211
✦Screw and washer assy (outer valve body to detent retainer)	77629	Shaft (front suspension arm)	3056-7
✦Screw and washer assy (outer valve body to inner valve body)	77631	Shaft (oil pump drive idler)	6656
✦Screw and washer assy (outer valve body to inner valve body)	77633	Shaft (speedometer cable)	17262
Screw & washer assy (turn signal handle & shank to steering column)	13322	Shaft (transmission main)	7061
Screw, shaft & pinion assy (starter drive)	11354	Shaft (transmission overdrive control)	7686
✦Seal (accelerator bell crank)-inner	99770	Shaft (transmission reverse idler)	7140
✦Seal (accelerator bell crank)-outer	99773	Shaft assy (distributor)	12175
Seal (fender to grille extension)	16247	Shaft assy (drive)	4605
✦Seal (flywheel housing front cover)	6411	Shaft assy (oil pump)	6608
Seal (fresh air heater blower)	18482	Shaft assy (starter)	11366
Seal (front suspension arm shaft)	3074-6	Shaft assy (steering gear sector)	3575
Seal (front suspension lower arm shaft)	3088	✦Shaft assy (transmission output)	77061
Seal (fuel pump oil)	9469	Shaft and bearing assy (rear axle)	4234
Seal (fuel tank filler to floor pan)	9072	Shaft and bracket assy (accelerator)	9725
Seal (headlamp door)	13054	Shaft and bracket assy (clutch and brake pedal)	2473
Seal (heater blower)	18482	Shaft and lever assy (carburetor choke)	9546
Seal (intake valve guide bushing)	6571	Shaft and lever assy (carburetor choke housing)	99557
Seal (oil pump body to cylinder block)	6643	Shaft & ring assy (transmission overdrive main)	7749
Seal (quarter panel wheel opening cover)	7227986-7	Shaft and ring gear assy (trans. overdrive main)	7652
Seal (rear bumper stone deflector)-center	17832	Shaft and universal joint assy (drive)	4602
Seal (rear bumper stone deflector)-outer	17844	Shaft and worm assy (steering column)	3524
Seal (speedometer drive gear oil)	17293	Shell (wheel hub cap)	1129
✦Seal (starter motor to dust cover)	6436	Shield (accelerator pedal dust)	9776
Seal (steering idler arm)	3359	Shield (radiator support to frt cross member splash)	16554-5
Seal (steering linkage ball stud)	3332	✦Shield (transmission extension rear oil seal)	7692
✦Seal (transmission access hole cover)	7312181	Shield assy (radiator splash)	8209
		✦Shim (accelerator bell crank bracket)	99772
		Shim (differential bearing adjusting)	4067
		Shim (driving pinion front bearing adjusting)	4672
		Shim (driving pinion rear bearing adjusting)	4109
		Shim (flywheel housing to cylinder block)	6400
		Shim (front spring)	5355
		Shim (steering column bracket)	3682
		✦Shim (transmission reverse shifter bracket)	77291
		Shock absorber assy (front)	18045

✦ Used with HYDRA-MATIC transmission

## Alphabetical Index—Continued

Part Name	Basic Part No.	Part Name	Basic Part No.
Shock absorber assy (rear)	18080	Spacer (steering column housing to fender apron)	3667
Shock Absorber Group (Page 299)		Spacer (steering gear housing to frame)	3566
Shoe & lining assy (rear brake)	2219	Spacer (transmission countershaft gear bearing)	7115
Silencer (hood top panel to front strainer)	16633	Spacer (transmission countershaft gear bearing)	7125
Sleeve (hood catch control cable)	16877	Spacer (transmission gear shift arm hub)	7336
Sleeve (starter drive)	11357	Spacer (trans. reverse planet carrier)	77179
Sleeve (steering column bearing)	3518	Spacer (windshield wiper)	17515
Sleeve (transmission gear shift lever socket)	7224	Spacer assy (hood rear)	16640
Sleeve (transmission gear shift rod adjustment)	7353	Spacer assy (W/S wiper mounting)	17519
+ Sleeve (transmission governor oil delivery)	77402	Spacer assy (W/S wiper mounting)	17520
Sleeve (transmission governor gear pinion)	6934	Spare Tire Valve Air Extension Group (Page 353)	
Sleeve (transmission interlock)	7233	Spare Wheel Clamp Group (Page 2)	
Sleeve (trans. intermediate and high clutch hub)	7106	Speaker assy (rear seat)	18875
Sleeve (valve spring retainer)	6517	Speedometer assy	17255
Sleeve (wire terminal insulating)	14455	Speedometer Casing & Shaft Chart (Page 277)	
Sleeve assy (drag link adjusting)	3310	Speedometer Group (Page 276)	
+ Sleeve assy (transmission oil supply to clutches)	77027	Spider assy (universal joint)	7084
Slinger (crankshaft oil)	6310	Spindle (hood guide roller)	16663
Slinger (driving pinion shaft oil)	4670	Spindle assy (front wheel)	3105
Slinger (water pump shaft)	8550	Spindle and impeller assy (fan hub)	8639
Snap ring (brake master cylinder piston)	2174	Spotlight (less bracket)	18148
Snap ring (starter drive pinion and barrel)	11370	Spotlight Group (Page 352)	
+ Snap ring (torus retaining)	7917	+ Spring (accelerator bell crank)	99768
Snap ring (trans. main drive gear bearing to shaft)	7064	Spring (accelerator pedal)	9737
Snap ring (trans. main gear retainer)	7026	Spring (battery drain hose to frame)	16377
Snap ring (transmission main shaft)	7160	Spring (brake adjusting screw)	2049
Snap ring (transmission main shaft rear bearing)	7030	Spring (brake drum silencer)	1140
Snap ring (transmission overdrive cover plate)	7666	Spring (brake pedal retracting)	2456
Snap ring (trans. overdrive main shaft bearing)	7656	Spring (brake master cylinder piston return)	2177
+ Snap ring (trans. output shaft center brg. retainer)	77069	Spring (brake shoe hold down)	2068
+ Snap ring (trans. rear oil pump gear retaining)	77142	Spring (brake shoe retracting)	2036
Snap ring (trans. reverse clutch piston spring retainer)	77596	Spring (carburetor accel. pump check ball retainer)	9575
+ Snap ring (trans. reverse internal gear retaining)	77138	Spring (carburetor accelerator pump piston)	9636
+ Snap ring (trans. reverse planet carrier retaining)	77148	Spring (carburetor accel pump piston cup expander)	9650
Snap ring (universal joint spider bearing retainer)	7096	Spring (carburetor accel. pump rod packing)	9986
Socket (brake adjusting screw)	2048	Spring (carburetor float)	9958
Socket (clutch shaft ball)	7517	Spring (carburetor filter screen)	99527
Socket (transmission gear shift lever)	7228	Spring (carburetor idle adjusting needle)	9578
Socket assy (dome lamp)	13793	Spring (clutch & brake pedal retracting)	7523
Socket assy (transmission gear shift lever)	7214	Spring (clutch release bearing)	7562
Socket and wiring assy (courtesy lamp)	13720	Spring (clutch release shaft)	7545
Socket and wiring (map light)	15650	Spring (cylinder block oil relief valve)	6654
Socket and wiring assy (parking lamp)	13234	Spring (distributor diaphragm)	12225
Socket and wiring assy (rear lamp)	13410	Spring (distributor governor anti rattle)	12319
Solenoid assy (transmission overdrive)	6916	Spring (distributor shaft)	12213
Solution (W/S washer)	19550	Spring (distributor terminal housing brush)	12321
Spacer (back up lamp mounting)	15529	Spring (exhaust thermostat control valve)	9688
Spacer (back up lamp mounting)	15532	Spring (front)	5310
Spacer (bumper guard to impact bar)	17759	Spring (front oil relief valve)	6654
Spacer (carburetor)	9603	Spring (front wheel brake cylinder piston return)	2205
Spacer (distributor cam)	12317	Spring (fuel & vacuum pump rocker arm return)	9380
Spacer (fan blade)	8621	Spring (fuel pump diaphragm)	9396
Spacer (fuel & vacuum pump rocker arm link)	9377	Spring (gear shift anti vibrator)	7242
Spacer (fuel & vacuum pump rocker arm link)	9382	Spring (generator brush)	10057
Spacer (guard to impact bar bolt)	17759	Spring (hand brake equalizer lever retracting)	2456
Spacer (hood ornament)	8219	Spring (headlamp bulb ring)	13031
Spacer (horn bracket)	13827	Spring (hood auxiliary catch)	16897
Spacer (radio antenna grounding)	18947	Spring (hood hinge)	16812
Spacer (rear bumper to frame brace)	17791	Spring (hood latch trigger)	16921
Spacer (rear spring clamp)	5738	Spring (hood lock)	16925
Spacer (rear window wiper)	17414	Spring (hood support)	16789
Spacer (roadlamp)	15209	Spring (horn ring)	3626
Spacer (spring clamp)	5703	Spring (ignition switch retaining)	11581
		Spring (oil pump relief valve)	6670

+ Used with HYDRA-MATIC transmission

## Alphabetical Index — Continued

Part Name	Basic Part No.	Part Name	Basic Part No.
Spring (oil pump screen)	6628	Stud (Rear view mirror attaching)	17737
Spring (parking brake strut to shoe)	2139	Stud assy (rear shock absorber)	18152
Spring (ratchet bar locking)	2788	Studs and shackle assy (rear spring)	5713
Spring (rear fender gas tank filler neck lid hinge)	16377	Stud and washer assy (rear shock absorber)	18165
Spring (rear wheel brake cylinder piston return)	2204	Sump assy (oil pan)	6695
Spring (roadlamp adapter retainer)	15231	Support (electric junction block)	14587
Spring (starter brush)	11059	Support (fresh air control cable)	14566
Spring (starter drive)	11375	Support (horn button wire contact)	3646
Spring (starter drive meshing)	11368-	Support (radiator grille)-center	8179
Spring (steering column bearing)	3520	Support (radiator grille)-inner	8428-c
Spring (steering wheel emblem)	3661	Support (radio receiver rear)	18888
Spring (throttle adjusting screw)	9578	Support (radio receiver rear)	18890
*Spring (transmission clutch release)-inner	77578	Support (steering idler arm)	3351
*Spring (transmission clutch release)-outer	77582	*Support (transmission reverse internal gear)	77133
*Spring (transmission front pump by pass valve)	77419	Support assy (engine front)	6038
*Spring (transmission front servo booster)	77425	Support assy (engine rear)	6068
*Spring (trans. front servo check valve)	77395	Support assy (front fender apron and radiator)	16138
*Spring (transmission front servo retracting)	77424	Support assy (generator)	10151
*Spring (transmission gear shift anti-vibrator)	7242	Support assy (hood)	16782-3
Spring (transmission gear shift neutral)	7389	Support assy (hood latch)	16774
Spring (transmission gear shift selector)	7293	Support assy (radiator)	8496
Spring (trans. intermediate and high clutch hub)	7109	Support assy (radiator grille)	8447
*Spring (transmission manual valve detent)	77605	Support assy (radiator grille)	8454
Spring (transmission mesh lock)	7234	Support assy (radiator grille)	8455
*Spring (transmission oil pressure regulator)	77387	Support assy (spindle)	3052-3
Spring (transmission overdrive retractor)	7685	Switch (direction turn signal)	13335
Spring (trans. parking blocker piston)	77325	Switch (roadlamp)	15224
Spring (trans. parking brake pawl return)	77313	Switch (stop light)	13480
*Spring (transmission rear servo)-inner	77455	Switch assy (back up lamp)	15220
*Spring (transmission rear servo booster)	77459	Switch assy (courtesy lamp)	13713
*Spring (transmission rear servo outer)	77465	Switch assy (dome lamp)	13752
*Spring (transmission rear servo pressure)	77450	Switch assy (dome lamp)	13754
*Spring (transmission rear servo tension)	77453	Switch assy (foot dimmer)	13532
*Spring (transmission reverse anchor retractor)	77134	Switch assy (hand brake signal lamp)	15852
Spring (trans. reverse blocker piston)	77155	Switch assy (headlamp control hand)	11654
Spring (trans. reverse clutch release)	77592	Switch assy (headlamp foot dimmer)	13532
Spring (trans. reverse clutch piston release)	77595	Switch assy (fresh air hot water heater control)	18578
*Spring (transmission torus check valve)	7922	Switch assy (ignition)	11572
Spring (turn signal switch pawl)	13316	Switch assy (instrument panel lights)	13740
Spring (turn signal switch plate retainer)	13343	Switch assy (map lamp)	13764
Spring (vacuum pump diaphragm)	99396	Switch assy (map light)	15653
Spring (valve)	6513	Switch assy (roadlamp)	15224
Spring assy (rear)	5560	Switch assy (spotlight)	15332
Spring & retainer assy (brake master cyl. return)	2145	Switch assy (stop light)	13480
Stabilator assy	5482	Switch assy (starter push button)	11500
Starter assy	11002	Switch assy (trans. overdrive accel. kick down)	6918
Starter Chart (Page 209)		Switch assy (transmission overdrive governor)	6919
Starter Drive Chart (Page 212)		Switch assy (transmission overdrive rail)	6917
Starter Drive Group (Page 211)		*Switch and bracket assy (trans. gear shift neutral)	15812
Starter Group (Page 209)		Switch and housing assy (dome lamp)	13752
Starter Switch Group (Page 212)		Switch and wire assy (luggage compartment)	13546
Steering Column Gear Shift Chart (Page 120)		Switch and wiring assy (turn signal)	14486
Steering Column Gear Shift Group (Page 117)		Switch, socket & wiring assy (glove compt. lamp)	14413
Steering Gear Group (Page 24)		Synchronizer (transmission)	7124
Steering Linkage Group (Page 23)			
*Stop (governor plunger)	77394		
*Stop (transmission band anchor)	77515		
Stop (transmission parking blocker piston spring)	77327		
Strap (hydraulic pump to ground)	14519		
Strap (ignition coil)	12043		
Strut (parking brake)	2108		
Stud (carburetor pump operating rod)	9988		
Stud (oil pump idler)	6606		
* Used with HYDRA-MATIC transmission			

— T —

Tank assy (fuel)	9002
Tee (1/4" flared tube and 1/4" pipe thread)	6073
Tee (vacuum antenna)	18848
Tee assy (W/S washer)	17587
Tensioner assy (cable drive W/S wiper)	17590-1
Terminal (battery cable)	14452
Terminal (eyelet)-end type	14462
Terminal (starter field)	11102



## Alphabetical Index—Continued

Part Name	Basic Part No.	Part Name	Basic Part No.
Terminal (wire)	14463	†Valve assy (trans. oil control)	77201
Thermostat assy (water)	8575	Valve assy (W/S washer pump)	17642
Tire inflator and fire extinguisher assy	17940	Vanity Mirror Group (Page 353)	
Tools Group (Page 275)		Vent assy (trans. extension bearing & seal assy)	7034
†Torus assy (transmission assy driving)	7914	Venturi (carburetor secondary)	9983
†Torus assy (transmission driven)	7910	Voltage Regulator (see Cutout and Voltage Regulator (Page 200))	
Transmission Gear Shift Housing, Levers, Cam and Shafts Group (Page 129)		— W —	
Transmission Group (Page 90)		Washer (back up lamp mounting)	15523
Transmission Overdrive Group (Page 83)		Washer (battery bracket)-Rubber	700045
†Transmission assy	7003	Washer (battery non flooding cover)	10664
†Transmission and torus assy	7000	Washer (blower motor to housing)	18580
Tray assy (headlamp control)	7004658	Washer (brake shoe anchor pin)	2029
Tray assy (instrument control panel)	7004694	Washer (carburetor accelerator pump spring)	9632
Tray assy (W/S wiper control)	7004658	Washer (clutch release equalizer shaft)	7539
Tray and support assy (battery)	10732	Washer (differential gear thrust)	4228
Tube (carburetor air horn ventilator)	9943	Washer (differential pinion thrust)	4230
Tube (distributor vacuum)	12226	Washer (distributor shaft thrust)-lower	12179
Tube (field coil lead conn. insulating)	10195	Washer (distributor shaft thrust)-upper	12318
Tube (thermostat choke control)-inlet	9820	Washer (emergency lever anti rattle)	2132
Tube (thermostatic choke control heat)	9890	Washer (front hub bearing retainer)	1195
†Tube (transmission oil filler)	77020	Washer (fuel & vacuum pump rocker arm pin)	9418
Tube (trans. pressure regulator reverse oil)	77467	Washer (fuel pump vacuum pump cover plate screw)	9357
Tube (trans. reverse clutch oil)	77593	Washer (generator field terminal)	10209
Tube (water regulator valve supply)	18461	Washer (mirror to visor)	13817
Tube assy (carburetor main well)	9991	Washer (non-flooding cover)	10664
Tube assy (crankcase ventilation)	6758	Washer (pivot shaft mounting spacer)	17541
Tube assy (cylinder block water)	6178-9	Washer (rear window wiper cup)	17417
Tube assy (oil filter inlet)	6716	Washer (roadlamp mounting)	15211
Tube assy (oil filter outlet)	6718	Washer (shock absorber)	18039-40
Tube assy (oil level indicator)	6754	Washer (shock absorber insulator)	18039
Tube assy (thermostat choke control)-outlet	9819	Washer (shock absorber insulator)	18041
Tube assy (transmission gear shift)	7212	Washer (starter armature thrust)	11036
Tube assy (vacuum booster to W/S wiper hose)	17536	Washer (starter drive shaft spring screw lock)	11379
Tube assy (vacuum pump to valve chamber cover)	9413	Washer (starter field terminal)	11093
Tube and retainer assy (steering column)	3514	Washer (starter field terminal)	11095
Tube & selector spring assy (trans. gear shift)	7209	Washer (starter field terminal insulator)	11094
Turn Indicator Group (Page 211)		Washer (steering sector thrust)	3579
— U —		Washer (steering shaft)	3738
"U" bolt (engine rear support)	66073	Washer (steering thrust screw)	3564
Undercoating (body)	19515	Washer (transmission countershaft gear thrust)	7119
Utility Lamp Group (Page 353)		Washer (transmission countershaft gear thrust)	7129
— V —		Washer (transmission countershaft gear thrust)	7154
Valve assy (automatic temperature water regulator)	18502	†Washer (trans. front clutch drum rear backing)	77530
Valve (exhaust)	6505	†Washer (transmission front clutch rear thrust)	77189
Valve (exhaust thermostat)	9685	†Washer (transmission front cover to pump screw)	77336
Valve (intake)	6507	†Washer (transmission front planetary assy front)	77190
†Valve (trans. fourth to third speed down shift)	77231	†Washer (trans. front planetary assy front backing)	77184
Valve (trans. front pump by pass)	77333	†Washer (transmission front pump locating)	77342
†Valve (trans. front pump pressure regulator)	77385	†Washer (transmission mainshaft nut lock)	7924
†Valve (transmission front pump by pass)	77333	†Washer (transmission mainshaft thrust)	77032
†Valve (transmission manual control)	77603	†Washer (transmission rear clutch hub thrust)	77581
†Valve (transmission torus check)	7916	Washer (trans. reverse clutch release spring retainer)	77590
Valve assy (brake master cylinder)	2178	Washer (transmission reverse idler gear thrust)	7728
Valve assy (carburetor power jet)	9594	Washer (trans. reverse internal gear thrust)	77146
Valve assy (fuel pump)	9352	†Washer (trans. reverse internal gear support screw)	77156
Valve assy (hot water heater shut off)	18495	†Washer (transmission reverse sun gear backing thrust)	77154
Valve assy (hydraulic tappet check)	6508	†Washer (transmission reverse sun gear thrust)	77153
Valve assy (radio antenna)	18863	Washer (vacuum antenna)	18966
† Used with HYDRA-MATIC transmission		Washer (vibration dampner to crankshaft)	6378
		Washer (W/S wiper)-outer	17541
		Water Pump Chart (Page 151)	

## Alphabetical Index—Continued

Part Name	Basic Part No.	Part Name	Basic Part No.
Water Pump Group (Page 150)		Wiring assy (headlamp)	14445
Wax (body polishing)	19534	Wiring assy (body wiring to dome lamp)	14334
Weatherseal assy (clutch & brake pedal)	2476	Wiring assy (cigar lighter)	14350
Weatherstrip (front fender apron to dash panel)	16263	Wiring assy (cigar lighter)-rear	14336
Weatherstrip (front fender brace)	16132	Wiring assy (coil to distributor low tension)	14302
Weatherstrip (steering column dash cover plate)	7312156	Wiring assy (excessive heat indicator)	14432
Weatherstrip (steering column to dash cover plate)	7012156	Wiring assy (front seat back cigar lighter)	14350
Wedge (steering column tube flange)	3641	Wiring assy (front window switches to body harness)	13708
Weight assy (distributor)	12188	Wiring assy (fuel gauge tank unit)	14406
Wheel assy	1015	Wiring assy (generator to voltage regulator)	14305
Wheel assy (fresh air hot water heater blower)	18504	Wiring assy (headlamp)	11653
Wheel assy (steering)	3600	Wiring assy (headlamp lead)	13076
Wheels, Hubs, Bearings, Caps, Etc. Group (Page 1)		Wiring assy (hydraulic seat regulator)	14530
Wick (distributor shaft)	12133	Wiring assy (hydraulic window regulator)	14531
Wick (driving pinion shaft oil seal)	4673	Wiring assy (ignition circuit to overdrive relay)	14396
Windshield Washer Group (Page 285)		Wiring assy (instrument lamp)	13710
Windshield Wiper Group (Page 279)		Wiring assy (instrument panel)	14401
Wire (back up lamp)	15527	Wiring assy (luggage compartment lamp)	13549
Wire (regulator cover sealing)	10649	Wiring assy (radio pilot lamp jumper)	14533
Wire (resistor to field terminal connector)	10625	Wiring assy (rear lamps)	14405
Wire (roadlamp ground)	15239	Wiring assy (rear window switches to body harness)	14339
Wire assy (back up lamp)	15525	Wiring assy (regulator to generator)	14305
Wire and fuse assy (ignition switch to heater switch)	14309	Wiring assy (starter switch to transmission lock switch)	14476
Wire assy (back up lamp switch to lamp)	15506	Wiring assy (stop light switch)	14475
Wire assy (coil to distributor)	12298	Wiring assy (trans. O/Drive harness to ignition coil)	14381
Wire assy (distributor breaker ground)	12264	Wiring assy (trans. overdrive solenoid to relay)	14382
Wire assy (distributor terminal primary)	12216	Wiring assy (window regulator switch to solenoid)	14508
Wire assy (electric clock)	15026	Wiring assy (window switches)	14531
Wire assy (heater jumper)	14309	Wiring & socket assy (parking lamp)	13234
Wire assy (lamp to rear R.H. door switch)	14318	Wiring & socket assy (rear lamp)	13410
Wire assy (left roadlamp to right lamp)	14369	Wiring & socket assy (rear license lamp)	13412
Wire assy (roadlamp lead)	15244	✦Wire & socket assy (trans. gear shift indicator lamp)	14402
Wire assy (roadlamp switch to headlamp switch)	15248	Wrench (hex open end)	17015
Wire assy (roadlamp switch to left lamp)	15246	Wrench (hex open end)	17016
Wire assy (spark plug)	12282-87	Wrench & jack (handle wheel nut)	17035
Wire assy (spark plug)	12295-96		
Wire assy (top control switch to solenoid)	14332	—Y—	
Wire, fuse & holder assy (rear seat cigar lighter)	14409	Yoke (coupling shaft flange)	4866
Wiring (hydraulic window switch jumper)	14535	Yoke (roadlamp adjusting screw)	15258
Wiring Group (Page 236)			

# FINISH OF STANDARD PARTS

(BOLTS, SCREWS, NUTS, WASHERS, Etc.)

The "S" suffix on numbers covering Standard Parts represents the finish of the part as shown by the following list:

SUFFIX	FINISH	SUFFIX	FINISH
<b>S</b>	Plain	<b>S18</b>	Case hardened
<b>S2</b>	Raven finish	<b>S19</b>	Brass plate
<b>S3</b>	Black Japan	<b>S20</b>	Cement coated
<b>S4</b>	Raven finish and black paint	<b>S21</b>	Lacquer for identification
<b>S5</b>	Copper plate	<b>S22</b>	Chrome plate—Butler finish
<b>S6</b>	Nickel plate	<b>S23</b>	Rustless steel—head polished
<b>S7</b>	Cadmium plate	<b>S24</b>	Hot tin coated
<b>S8</b>	Zinc plate	<b>S29</b>	Clear enamel over bright zinc
<b>S10</b>	Tinned	<b>S30</b>	Gold tinted enamel over bright zinc
<b>S12</b>	Lacquer to match trim	<b>S31</b>	Cadmium with zinc
<b>S13</b>	Chrome plated	<b>S32</b>	Raven finish prime
<b>S14</b>	Nickel plate—Butler finish	<b>S33</b>	Case hardened raven finish
<b>S15</b>	Oxidized	<b>S34</b>	Case hardened cadmium finish
<b>S16</b>	Lead coated		

## DECIMAL EQUIVALENTS OF PARTS OF AN INCH

1/64...015625	11/32...34375	43/64...671875
1/32...03125	23/64...359375	11/16...6875
3/64...046875	3/8...375	45/64...703125
1/16...0625	25/64...390625	23/32...71875
5/64...078125	13/32...40625	47/64...734375
3/32...09375	27/64...421875	3/4...75
7/64...109375	7/16...4375	49/64...765625
1/8...125	29/64...453125	25/32...78125
9/64...140625	15/32...46875	51/64...796875
5/32...15625	31/64...484375	13/16...8125
11/64...171875	1/2...5	53/64...828125
3/16...1875	33/64...515625	27/32...84375
13/64...203125	17/32...53125	55/64...859375
7/32...21875	35/64...546875	7/8...875
15/64...234375	9/16...5625	57/64...890625
1/4...25	37/64...578125	29/32...90625
17/64...265625	19/32...59375	59/64...921875
9/32...28125	39/64...609375	15/16...9375
19/64...296875	5/8...625	61/64...953125
5/16...3125	41/64...640625	31/32...96875
21/64...328125	21/32...65625	63/64...984375
		1...1.

## SPECIAL NOTE on Indexing of Bolts, Nuts, Screws, Washers, Rivets, etc.

Bolts, screws, studs and rivets are listed in order according to diameter thread and length.

For example: 24325-S8 1/4"-28 x 5/8"-diameter 1/4"-threads to one inch 28—length 5/8".





Nuts are listed according to inside diameter and thread.

For Example: 33795-S7 1/4"-20 (3/32" x 1/16") inside diameter 1/4"-threads to one inch 20—thickness 3/32"—outside diameter across flats 1/8".

Washers are listed according to size of hole.

For Example: 44720-S8 1/4" (1/16" x 3/4") size of bolt on which used 1/4"—thickness 1/16"—outside diameter 3/4".

## Nuts, Bolts, Screws, Washers and Rivets (Other Than Special) By Size

<p><b>HEX HEAD BOLT</b></p>  <p>20247-S 7/16"-20 x 2-1/2" 20304-S2 1/4"-20 x 7/16" 20384-S2 1/4"-20 x 1" 20345-S2 1/4"-28 x 3/4" 20310-S8 5/16"-18 x 1/2" 20326-S7 5/16"-18 x 5/8" 20220-S 5/16"-18 x 2" 20303-S8 5/16"-24 x 3/8" 20319-S7 5/16"-24 x 9/16" 20328-S 3/8"-16 x 5/8" 20418-S7 3/8"-16 x 1-3/16" 20506-S7 3/8"-16 x 1-3/4" 20222-S8 3/8"-16 x 2" 20449-S2 3/8"-24 x 1-3/8" 21556-S7 3/8"-24 x 3-1/4" 20350-S7 7/16"-14 x 3/4" 20470-S8 7/16"-14 x 1-1/2" 20246-S8 7/16"-14 x 2-1/2" 20550-S8 7/16"-14 x 2-3/4" 20525-S 7/16"-20 x 2" 20392-S 1/2"-13 x 1" 20132-S2 1/2"-13 x 1-1/4" 20252-S2 1/2"-13 x 2-3/4" 25164-S8 1/2"-20 x 3-1/2" 20702-S 5/8"-18 x 1-7/16" 20747-S7 5/8"-18 x 1-3/4"</p>	<p>24325-S8 1/4"-28 x 5/8" 24336-S7 5/16"-18 x 11/16" 24346-S7 5/16"-18 x 3/4" 24386-S8 5/16"-18 x 1" 24466-S7 5/16"-18 x 1-1/2" 24311-S8 5/16"-24 x 1/2" 24327-S7 5/16"-24 x 5/8" 24347-S8 5/16"-24 x 3/4" 24387-S7 5/16"-24 x 1" 24427-S7 5/16"-24 x 1-1/4" 24348-S8 3/8"-16 x 3/4" 24388-S8 3/8"-16 x 1" 24349-S7 3/8"-24 x 3/4" 24389-S8 3/8"-24 x 1" 24429-S7 3/8"-24 x 1-1/4" 24469-S7 3/8"-24 x 1-1/2" 24523-S8 3/8"-24 x 2" 24541-S7 3/8"-24 x 2-3/8" 24433-S7 1/2"-20 x 1-1/4" 24473-S7 1/2"-20 x 1-1/2" 24511-S7 1/2"-20 x 1-3/4"</p>	<p><b>HEX HEAD BOLT &amp; EXTERNAL TOOTH LOCKWASHER ASSY</b></p>  <p>42728-S8 No. 10-32 x 1/2" 42758-S8 5/16"-18 x 5/8" 42783-S8 3/8"-24 x 7/8"</p>	<p><b>FILLISTER HEAD SCREW</b></p>  <p>31061-S8 No. 8-32 x 1/2" 31077-S8 No. 8-32 x 5/8" 31596-S7 No. 10-32 x 3/8" 31628-S7 No. 10-32 x 5/8" 31079-S7 No. 12-24 x 5/8" 31144-S7 1/4"-20 x 1-1/4" 31598-S 1/4"-28 x 3/8"</p>
	<p><b>HEX HEAD BOLT SELF LOCKING</b></p>  <p>42911-S 1/4"-20 x 5/8" 42952-S 5/16"-18 x 1/2"</p>	<p><b>HEX HEAD BOLT &amp; SPLIT LOCKWASHER ASSY</b></p>  <p>43260-S8 1/4"-20 x 1/2" 43263-S8 1/4"-20 x 5/8" 42906-S8 1/4"-20 x 3/4" 43261-S8 1/4"-20 x 7/8" 42904-S8 1/4"-28 x 5/8" 42789-S8 5/16"-18 x 3/4" 42905-S8 5/16"-24 x 3/4" 43264-S8 5/16"-24 x 7/8"</p>	<p><b>FILLISTER HEAD SCREW POINTED</b></p>  <p>37643-S7 No. 6-32 x 7/16" 37611-S7 No. 8-32 x 1/4" 38018-S No. 8-32 x 5/16" 37624-S7 No. 12-24 x 5/16" 37657-S8 No. 12-24 x 1/2"</p>
<p><b>HEX HEAD BOLT-POINTED</b></p>  <p>24308-S7 1/4"-20 x 1/2" 24324-S7 1/4"-20 x 5/8" 24344-S7 1/4"-20 x 3/4" 24404-S7 1/4"-20 x 1-1/8" 24309-S8 1/4"-28 x 1/2"</p>	<p><b>HEX HEAD BOLT WIRE SIZE BODY</b></p>  <p>21492-S2 5/16"-24 x 1-7/8" 21566-S7 3/8"-24 x 3-1/4" 21481-S2 1/2"-20 x 1-3/4" 25156-S8 1/2"-20 x 2-5/8" 25168-S8 1/2"-20 x 4"</p>	<p><b>SQUARE HEAD BOLT</b></p>  <p>23017-S16 5/16"-18 x 1-1/4" 22994-S8 1/4"-20 x 7/8"</p>	<p><b>FILLISTER HEAD SCREW &amp; INTERNAL TOOTH LOCKWASHER ASSY</b></p> <p>42672-S8 No. 10-32 x 3/8"</p>
		<p><b>ROUND HEAD CARRIAGE BOLT</b></p>  <p>23376-S 1/4"-20 x 3/4" 23391-S2 1/4"-20 x 7/8" 23409-S7 5/16"-24 x 1 23440-S8 3/8"-16 x 1-1/4" 23426-S8 3/8"-24 x 1-1/8" 23441-S7 3/8"-24 x 1-1/4"</p>	<p><b>CROSS RECESSED FILLISTER HEAD BOLT &amp; SPLIT LOCKWASHER ASSY</b></p>  <p>50923-S8 No. 8-32 x 3/8" 50929-S8 No. 8-32 x 1/2"</p>

# Lincoln and Lincoln Cosmopolitan

## CHASSIS PARTS CATALOGUE

### Nuts, Bolts, Screws, Washers and Rivets

#### (Other Than Special) By Size













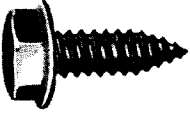

<p><b>FILLISTER HEAD BOLT &amp; SPLIT LOCKWASHER ASSY</b></p>  <p>43262-88 5/16"-24 x 7/8"</p>	<p><b>CROSS RECESSED PAN HEAD SCREW &amp; EXTERNAL TOOTH LOCKWASHER ASSY</b></p>  <p>30804-88 No. 10-32 x 3/8"</p>	<p>26462-87 No. 8-32 x 5/16"                  27068-87 No. 10-32 x 3/8"                  27097-82 No. 10-32 x 5/8"                  27113-87 No. 10-32 x 3/4"                  27145-813 No. 10-32 x 1"                  27153-87 No. 10-32 x 1-1/8"                  27177-87 No. 10-32 x 1-1/2"                  26498-87 No. 12-24 x 5/8"                  26514-82 No. 12-24 x 3/4"                  26148-8 5/16"-18 x 3/8"</p>	<p><b>CROSS RECESSED FLAT HEAD SELF TAPPING SCREW TYPE C</b></p>  <p>51145-813 No. 6-32 x 1/4"                  52018-88 No. 10-12 x 5/8"</p>
<p><b>FLAT HEAD SCREW</b></p>  <p>25218-88 No. 10-32 x 3/8"                  25231-87 No. 10-32 x 1/2"                  24666-87 5/16"-18 x 3/4"</p>	<p><b>PAN HEAD MACHINE SCREW POINTED</b></p>  <p>39075-88 5/16"-24 x 5/8"</p>	<p><b>ROUND HEAD SCREW-POINTED</b></p>  <p>36782-87 No. 6-32 x 1/4"                  36787-87 No. 6-32 x 5/16"</p>	<p><b>FLAT HEAD—SELF TAPPING SCREW SLOTTED END</b></p>  <p>41800-88 No. 6-32 x 1/4"</p>
<p><b>FLAT HEAD SCREW</b></p>  <p>35999-87 No. 8-32 x 1/2"                  36103-87 5/16"-18 x 1-1/8"</p>	<p><b>PAN HEAD SCREW &amp; EXTERNAL TOOTH LOCKWASHER ASSY</b></p>  <p>42802-88 No. 10-32 x 3/8"                  42817-88 1/4"-20 x 1/2"</p>	<p><b>ROUND HEAD SCREW &amp; EXTERNAL TOOTH LOCKWASHER ASSY</b></p>  <p>42649-88 No. 8-32 x 3/8"</p>	<p><b>HEX HEAD—SELF TAPPING SCREW</b></p>  <p>42007-88 No. 10-12 x 1/2"                  42014-88 No. 10-12 x 5/8"                  42021-88 No. 10-12 x 3/4"                  42032-88 No. 10-12 x 1"                  42037-88 No. 10-12 x 1-1/4"                  42023-87 No. 14-10 x 3/4"</p>
<p><b>CROSS RECESSED OVAL HEAD MACHINE SCREW</b></p>  <p>50386-813 No. 6-32 x 3/8"                  50399-823 No. 10-32 x 1/2"</p>	<p><b>PAN HEAD SCREW &amp; SPLIT LOCKWASHER ASSY</b></p>  <p>43377-88 No. 6-32 x 1/2"                  43243-88 No. 8-32 x 3/4"</p>	<p><b>FILLISTER HEAD SELF TAPPING SCREW SLOTTED END</b></p>  <p>41281-88 No. 8-32 x 1/4"                  41294-88 No. 8-32 x 3/8"</p>	<p><b>HEX HEAD SELF TAPPING TYPE C</b></p>  <p>40156-88 5/16"-18 x 5/8"</p>
<p><b>OVAL HEAD SCREW</b></p>  <p>29746-813 No. 6-32 x 5/16"                  28442-813 No. 8-32 x 3/4"</p>	<p><b>ROUND HEAD MACHINE SCREW</b></p>  <p>26455-88 No. 4-40 x 1/4"                  26451-87 No. 6-32 x 3/16"                  26466-86 No. 6-32 x 3/8"                  26479-87 No. 6-32 x 1/2"                  26452-87 No. 8-32 x 3/16"                  +27687-8 No. 8-32 x 3/16"                  26457-87 No. 8-32 x 1/4"</p>	<p><b>CROSS RECESSED FLAT HEAD SELF TAPPING SCREW</b></p>  <p>52017-88 No. 8-15 x 5/8"</p>	<p><b>HEX HEAD—SELF TAPPING SCREW-SLOTTED END</b></p>  <p>41178-88 No. 10-24 x 1/2"                  41036-88 No. 10-32 x 3/8"                  41181-88 1/4"-20 x 1/2"                  41220-88 1/4"-20 x 7/8"</p>

# Lincoln and Lincoln Cosmopolitan

## CHASSIS PARTS CATALOGUE

### Nuts, Bolts, Screws, Washers and Rivets

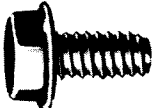
#### (Other Than Special) By Size

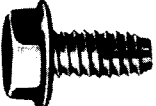
<p><b>HEX HEAD-SLOTTED SELF TAPPING SCREW TYPE B—REGULAR</b></p>  <p>31522-S7 No. 14-14 x 3/8"</p>	<p>40995-S8 No. 8-32 x 1-1/2" 40921-S8 1/4"-20 x 1/2"</p> <p><b>CROSS RECESSED OVAL HEAD SELF-TAPPING SCREW</b></p>  <p>52342-S13 No. 6-18 x 1/2" 52358-S23 No. 6-18 x 3/4" 52352-S13 No. 8-15 x 5/8" 52368-S23 No. 8-15 x 7/8" 52376-S13 No. 8-15 x 1" 52382-S13 No. 8-15 x 1-1/4" 52345-S13 No. 10-12 x 1/2"</p>	<p><b>CROSS RECESSED PAN HEAD SELF TAPPING SCREW TYPE D</b></p>  <p>51754-S8 No. 6-32 x 3/8"</p> <p><b>PAN HEAD SELF TAPPING SCREW TYPE B—POINTED</b></p>  <p>33427-S7 No. 6-20 x 1/4" 33444-S2 No. 10-16 x 1/2"</p>	<p><b>ROUND HEAD—SELF TAPPING SCREW</b></p>  <p>32859-S7 No. 10-12 x 1/2" 32859-S13 No. 10-12 x 1/2" 32873-S7 No. 10-12 x 3/4" 32889-S8 No. 10-12 x 1-1/4" 32853-S7 No. 12-11 x 3/8"</p>
<p><b>HEX WASHER HEAD SELF TAPPING SCREW</b></p>  <p>42134-S8 No. 10-12 x 5/8" 31497-S7 No. 14-10 x 1/2" 31498-S8 No. 14-10 x 5/8" 42143-S8 No. 14-10 x 3/4"</p>	<p><b>CROSS RECESSED PAN HEAD SELF TAPPING SCREW</b></p>  <p>52720-S8 No. 8-15 x 3/8" 52721-S8 No. 10-12 x 3/8" 52727-S8 No. 10-12 x 1/2" 52759-S8 No. 10-12 x 1-1/4" 52729-S8 No. 14-10 x 1/2"</p>	<p><b>PAN HEAD SELF TAPPING SCREW TYPE B—REGULAR</b></p>  <p>33169-S7 No. 8-18 x 1/4" 33170-S7 No. 10-16 x 1/4" 33206-S7 No. 14-14 x 7/8"</p>	<p><b>ROUND HEAD SELF TAPPING SCREW TYPE B—REGULAR</b></p>  <p>33104-S8 No. 8-18 x 1/4" 33121-S8 No. 14-14 x 1/2"</p>
<p><b>HEX WASHER HEAD SELF TAPPING SCREW TYPE B—REGULAR</b></p>  <p>42360-S8 No. 10-16 x 3/8" 31527-S7 No. 14-14 x 1/2"</p>	<p><b>PAN HEAD SELF TAPPING SCREW—SLOTTED END</b></p>  <p>41541-S8 No. 8-32 x 1/4" 41556-S8 No. 10-32 x 3/8"</p>	<p><b>PAN HEAD SELF TAPPING SCREW—TYPE C</b></p>  <p>40500-S8 No. 6-32 x 1/4" 40516-S8 No. 10-32 x 3/8" 40542-S8 No. 10-32 x 5/8"</p>	<p><b>ROUND HEAD TAPPING SCREW SLOTTED END</b></p>  <p>40631-S8 No. 8-32 x 1/2"</p>
<p><b>HEX WASHER HEAD SELF TAPPING SCREW TYPE C</b></p>  <p>39909-S7 5/16"-18 x 3/4"</p>	<p><b>PAN HEAD SELF TAPPING SCREW</b></p>  <p>32914-S8 No. 6-18 x 3/8" 32909-S8 No. 8-15 x 1/4" 32916-S8 No. 8-15 x 3/8" 32917-S7 No. 10-12 x 3/8" 32924-S8 No. 10-12 x 1/2" 32938-S7 No. 10-12 x 3/4" 32944-S2 No. 10-12 x 7/8" 31477-S2 No. 14-10 x 1/2"</p>	<p><b>PREVAILING TORQUE LOCKNUT</b></p>  <p>34443-S7 5/16"-24 (21/64" x 1/2") 34445-S7 3/8"-24 (13/32" x 9/16") 34447-S2 7/16"-20 (29/64" x 5/8") 34424-S7 1/2"-20 (7/16" x 3/4") 34449-S7 1/2"-20 (9/16" x 3/4") 34451-S 9/16"-18 (39/64" x 7/8")</p>	
<p><b>HEX WASHER HEAD SELF TAPPING SCREW TYPE D</b></p>  <p>40969-S8 No. 8-32 x 1"</p>			

# Lincoln and Lincoln Cosmopolitan

## CHASSIS PARTS CATALOGUE

### Nuts, Bolts, Screws, Washers and Rivets

#### (Other Than Special) By Size

<p><b>FREE RUNNING LOCKNUT</b></p>  <p>34390-S7 1/4"-20 (9/32" x 7/16")</p> <p>34392-S7 5/16"-18 (21/64" x 1/2")</p> <p>34393-S7 5/16"-24 (21/64" x 1/2")</p> <p>34370-S8 3/8"-24 (21/64" x 9/16")</p> <p>34395-S7 3/8"-24 (13/32" x 9/16")</p> <p>34397-S7 7/16"-20 (29/64" x 5/8")</p> <p>34399-S8 1/2"-20 (9/16" x 3/4")</p>	<p>33796-S7 1/4"-28 (7/32" x 7/16")</p> <p>34081-S7 1/4"-28 (3/16" x 7/16")</p> <p>33797-S7 5/16"-18 (17/64" x 1/2")</p> <p>33797-S16 5/16"-18 (17/64" x 1/2")</p> <p>33798-S8 5/16"-24 (17/64" x 1/2")</p> <p>33799-S7 3/8"-16 (21/64" x 9/16")</p> <p>33800-S8 3/8"-24 (21/64" x 9/16")</p> <p>33802-S8 7/16"-20 (3/8" x 5/8")</p> <p>+33816-S 7/16"-20 (3/8" x 5/8")</p> <p>33846-S8 1/2"-20 (7/16" x 3/4")</p> <p>33848-S7 9/16"-18 (31/64" x 7/8")</p> <p>33850-S2 5/8"-18 (35/64" x 15/16")</p>	<p><b>SPRING NUT</b></p>  <p>45017-S32 No. 10A (3/8" x 11/16")</p> <p>45015-S8 No. 10A (1/2" x 3/4")</p>	<p>72070-S 3/32" x 1-1/2"</p> <p>72010-S 1/8" x 5/8"</p> <p>72017-S 1/8" x 3/4"</p> <p>72035-S7 1/8" x 1"</p> <p>72054-S 5/32" x 1-1/4"</p>
<p><b>CASTLE NUT</b></p>  <p>33983-S7 1/2"-20 (7/16" x 3/4")</p> <p>34032-S7 1/2"-20 (9/16" x 3/4")</p>	<p><b>HEX CHECK NUT</b></p>  <p>33920-S 1/4"-20 (5/32" x 7/16")</p> <p>33907-S8 1/4"-28 (5/32" x 7/16")</p> <p>33922-S2 5/16"-18 (3/16" x 1/2")</p> <p>33923-S7 5/16"-24 (3/16" x 1/2")</p> <p>33929-S7 1/2"-20 (5/16" x 3/4")</p>	<p><b>SPRING NUT "U" SHAPE</b></p>  <p>45191-S8 No. 10-12 (1/2" x 61/64")</p>	<p><b>GROOVED PIN</b></p>  <p>72187-S7 1/16" x 1/2"</p>
<p><b>HEX NUT</b></p>  <p>34051-S7 No. 6-32 (7/64" x 5/16")</p> <p>34052-S7 No. 8-32 (1/8" x 11/32")</p> <p>34053-S8 No. 10-24 (1/8" x 3/8")</p> <p>34079-S7 No. 10-32 (1/8" x 3/8")</p> <p>34054-S8 No. 12-24 (5/32" x 7/16")</p> <p>33795-S7 1/4"-20 (7/32" x 7/16")</p>	<p><b>HEX STAMPED NUT</b></p>  <p>45218-S8 3/8"-24 (9/64" x 9/16")</p> <p>45219-S 7/16"-20 (5/32" x 5/8")</p>	<p><b>CLEVIS</b></p>  <p>97011-S7 1/4"-28 x 2"</p>	<p><b>STRAIGHT PIN</b></p>  <p>72798-S 1/8" x 7/16"</p> <p>73232-S 1/8" x 1/2"</p> <p>72867-S 1/8" x 7/8"</p> <p>72869-S 3/16" x 7/8"</p> <p>72909-S2 3/16" x 1-1/4"</p> <p>73259-S 3/8" x 5/8"</p>
<p>34051-S7 No. 6-32 (7/64" x 5/16")</p> <p>34052-S7 No. 8-32 (1/8" x 11/32")</p> <p>34053-S8 No. 10-24 (1/8" x 3/8")</p> <p>34079-S7 No. 10-32 (1/8" x 3/8")</p> <p>34054-S8 No. 12-24 (5/32" x 7/16")</p> <p>33795-S7 1/4"-20 (7/32" x 7/16")</p>	<p>33920-S 1/4"-20 (5/32" x 7/16")</p> <p>33907-S8 1/4"-28 (5/32" x 7/16")</p> <p>33922-S2 5/16"-18 (3/16" x 1/2")</p> <p>33923-S7 5/16"-24 (3/16" x 1/2")</p> <p>33929-S7 1/2"-20 (5/16" x 3/4")</p>	<p><b>CLEVIS PIN</b></p>  <p>73877-S7 1/4" x 25/32"</p> <p>73861-S 5/16" x 5/8"</p> <p>73880-S8 5/16" x 13/16"</p> <p>73896-S7 5/16" x 15/16"</p> <p>73911-S7 5/16" x 1-1/16"</p>	<p><b>TAPER PIN</b></p>  <p>73757-S 5/32" x 1-1/4"</p>
		<p><b>COTTER PIN</b></p>  <p>72003-S7 1/16" x 1/2"</p> <p>72015-S 1/16" x 3/4"</p> <p>72004-S7 3/32" x 1/2"</p> <p>72009-S 3/32" x 5/8"</p> <p>72016-S8 3/32" x 3/4"</p>	<p><b>EXPANSION PLUGS</b></p>  <p>74117-S 1"</p> <p>74121-S 1-1/4"</p>
			<p><b>PLUG BUTTON</b></p>  <p>74202-S 13/64"</p> <p>74246-S8 15/16"</p>

# Lincoln and Lincoln Cosmopolitan

## CHASSIS PARTS CATALOGUE

### Nuts, Bolts, Screws, Washers and Rivets

#### (Other Than Special) By Size

<p><b>LUBRICATOR FITTING STRAIGHT</b></p>  <p>87901-S8 1/8" -27 x 3/4" 87907-S8 1/4" -28 x 1/2"</p>	<p><b>FLAT WASHER</b></p>  <p>44707-S8 No. 6(3/64" x 3/8") 44713-S8 No.10(3/64" x 1/2") 44716-S8 No.10(3/64" x 9/16") 44815-S No.12(1/2 x 1/16") 44720-S8 1/4" (1/16" x 3/4") 44719-S8 1/4" (1/16" x 5/8") 44734-S8 1/4" (3/32" x 1-1/16") 44722-S8 5/16" (1/16" x 11/16") 44724-S8 5/16"(3/32" x 7/8") 44726-S8 3/8" (1/16" x 13/16") 34707-S2 3/8" (5/64" x 1") 44728-S8 3/8" (3/32" x 1") 44730-S8 7/16" (5/64" x 59/64") 44738-S8 9/16" (3/32" x 1-3/16") 34761-S7 5/8" (3/32" x 1-5/16")</p>	<p><b>STANDARD LOCKWASHER</b></p>  <p>34801-S7 No. 7 (1/32" x 1/4") 34802-S7 No. 8 (3/64" x 19/64") 34803-S7 No. 10 (3/64" x 21/64") 34804-S8 No. 12 (1/16" x 3/8") 34805-S8 1/4" (1/16" x 1/2") 34806-S7 5/16" (1/16" x 19/32") 34807-S2 3/8" (3/32" x 11/16") 34808-S8 7/16" (1/8" x 25/32") 34809-S8 1/2" (1/8" x 7/8") 34810-S2 9/16" (9/64" x 31/32") 34811-S2 5/8" (5/32" x 1-1/16") 34814-S 7/8" (7/32" x 1-15/32")</p>	<p>34902-S8 No. 8 (1/64" x 21/64") 34903-S8 No. 10 (1/64" x 3/8") 34904-S2 No. 12 (1/64" x 13/32") 34905-S7 1/4" (1/64" x 15/32") 34906-S8 5/16" (1/32" x 39/64") 34907-S7 3/8" (1/32" x 11/16") 34908-S2 7/16" (1/32" x 3/4") 34909-S7 1/2" (1/32" x 57/64") 34922-S 1/2" (1/16" x 59/64") 34910-S2 9/16" (1/32" x 31/32") 34913-S8 3/4" (3/64" x 1-15/64")</p>
<p><b>LUBRICATOR FITTING 90°</b></p>  <p>87381-S 1/4" -24</p>	<p><b>HEAVY LOCKWASHER</b></p>  <p>34846-S2 5/16" (3/32" x 19/32") 34849-S2 1/2" (5/32" x 57/64") 34851-S7 5/8" (3/16" x 41/64")</p>	<p><b>EXTERNAL TOOTH LOCKWASHER</b></p>  <p>34937-S7 No. 6 (1/64" x 5/16") 34938-S8 No. 8 (1/64" x 3/8") 34940-S2 1/4" (1/64" x 1/2") 34941-S7 5/16" (1/32" x 39/64") 34944-S2 1/2" (3/64" x 57/64")</p>	<p><b>STUD</b></p>  <p>88001-S8 5/16"-24 and 5/16"-18 x 7/8" 88351-S8 5/16"-24 and 5/16"-18 x 7/8" 88371-S 5/16"-24 and 5/16"-18 x 1-1/4" 88380-S7 3/8"-24 and 3/8"-18 x 1-3/8" 88452-S7 3/8"-24 and 3/8"-16 x 2-1/4" 88512-S7 3/8"-24 and 3/8"-16 x 3" 88393-S 7/16"-20 and 7/16"-14 x 1-1/2" 88413-S 7/16"-20 and 7/16"-14 x 1-3/4" 88473-S 7/16"-20 and 7/16"-14 x 2-1/2"</p>
<p><b>WOODRUFF KEY</b></p>  <p>74172-S 1/2" x 1/8" 74175-S 5/8" x 5/32" 74153-S 1" x 1/4"</p>	<p><b>LIGHT LOCKWASHER</b></p>  <p>34822-S7 No. 8 (1/32" x 1/4") 34823-S2 No. 10 (3/64" x 21/64") 34825-S8 1/4" (3/64" x 31/64") 34826-S7 5/16" (3/64" x 19/32") 34827-S2 3/8" (1/16" x 43/64") 34829-S2 1/2" (1/16" x 7/8")</p>	<p><b>INTERNAL TOOTH LOCKWASHER</b></p>  <p>34901-S7 No. 6 (1/64" x 9/32")</p>	<p><b>HEADLESS SET SCREW</b></p>  <p>89735-S18 No. 12-28 x 1/4"</p>



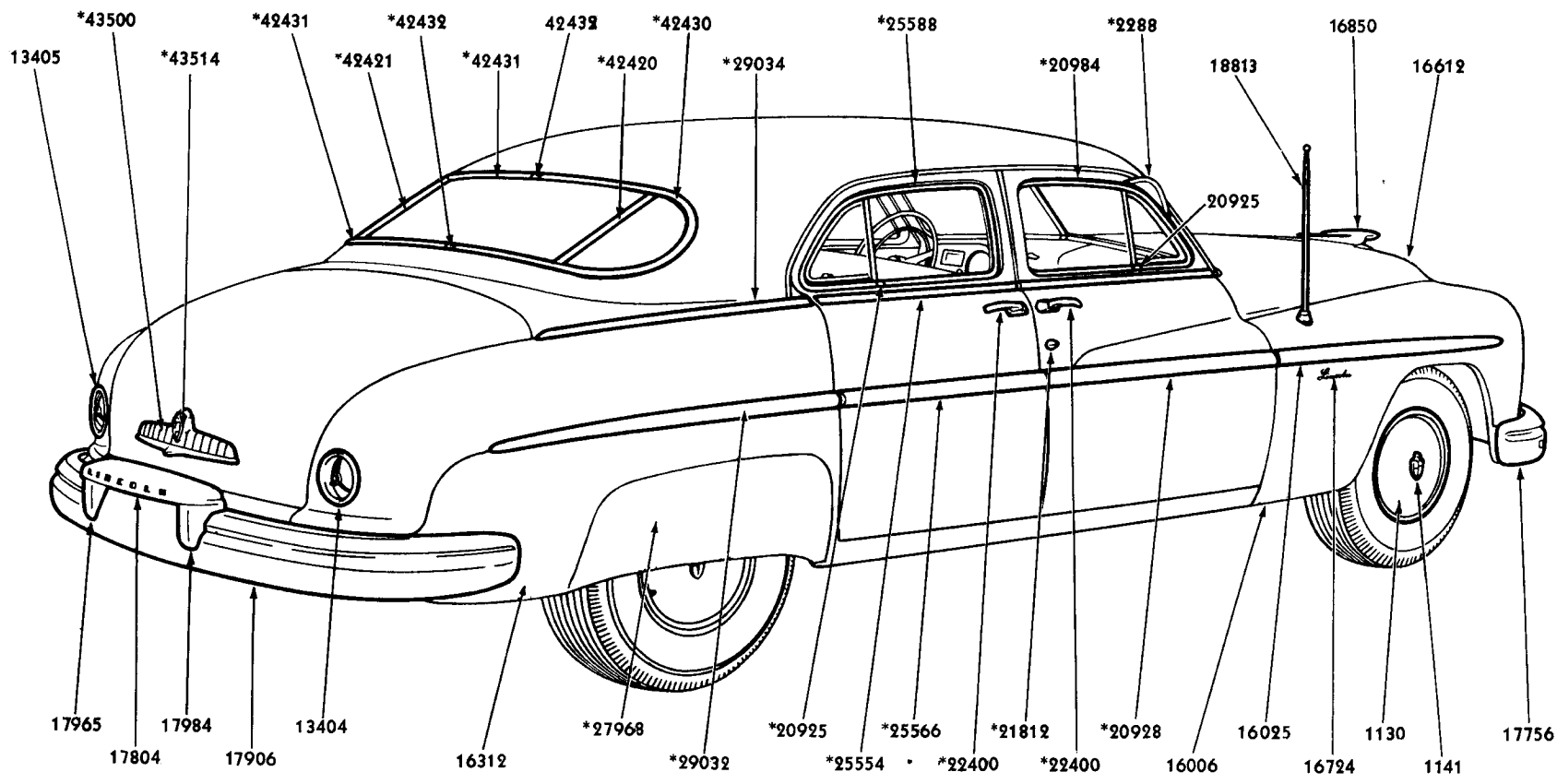

\* BODY GROUP NUMBER  
FOR ADDITIONAL INFORMATION REFER TO BODY PARTS LIST

PL-242

**1949 LINCOLN SPORT SEDAN EXTERIOR VIEW (BODY TYPE 74)**

Basic numbers only shown on illustration. Order by Part Numbers shown in list of parts.

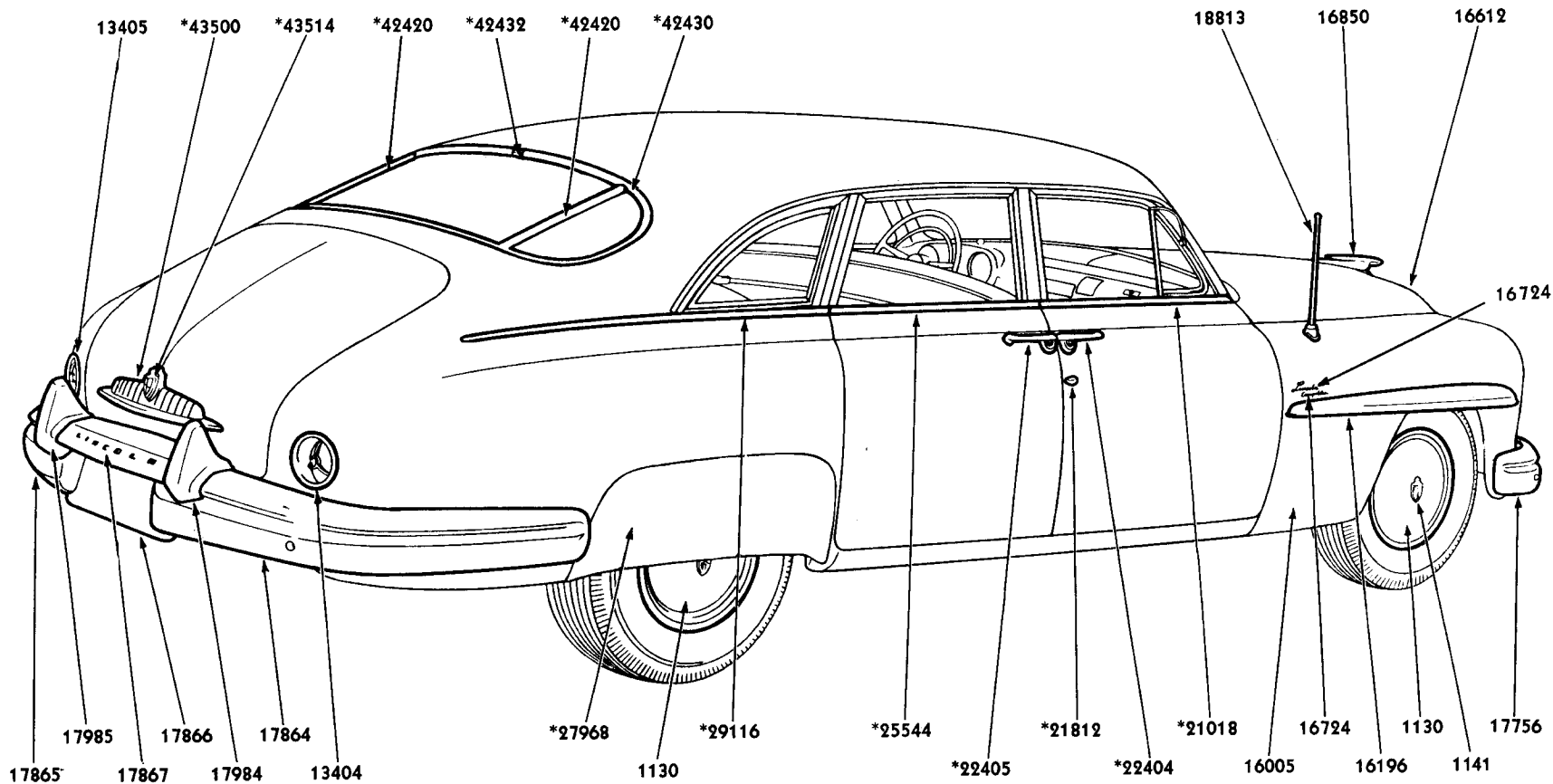

\* BODY GROUP NUMBER  
 FOR ADDITIONAL INFORMATION REFER TO BODY PARTS LIST

PL-241

**1949 LINCOLN COSMOPOLITAN TOWN SEDAN (BODY TYPE 73)**

Basic numbers only shown on illustration. Order by Part Numbers shown in list of parts.

*Lincoln and Lincoln Corporation*  
CHASSIS PARTS CATALOGUE

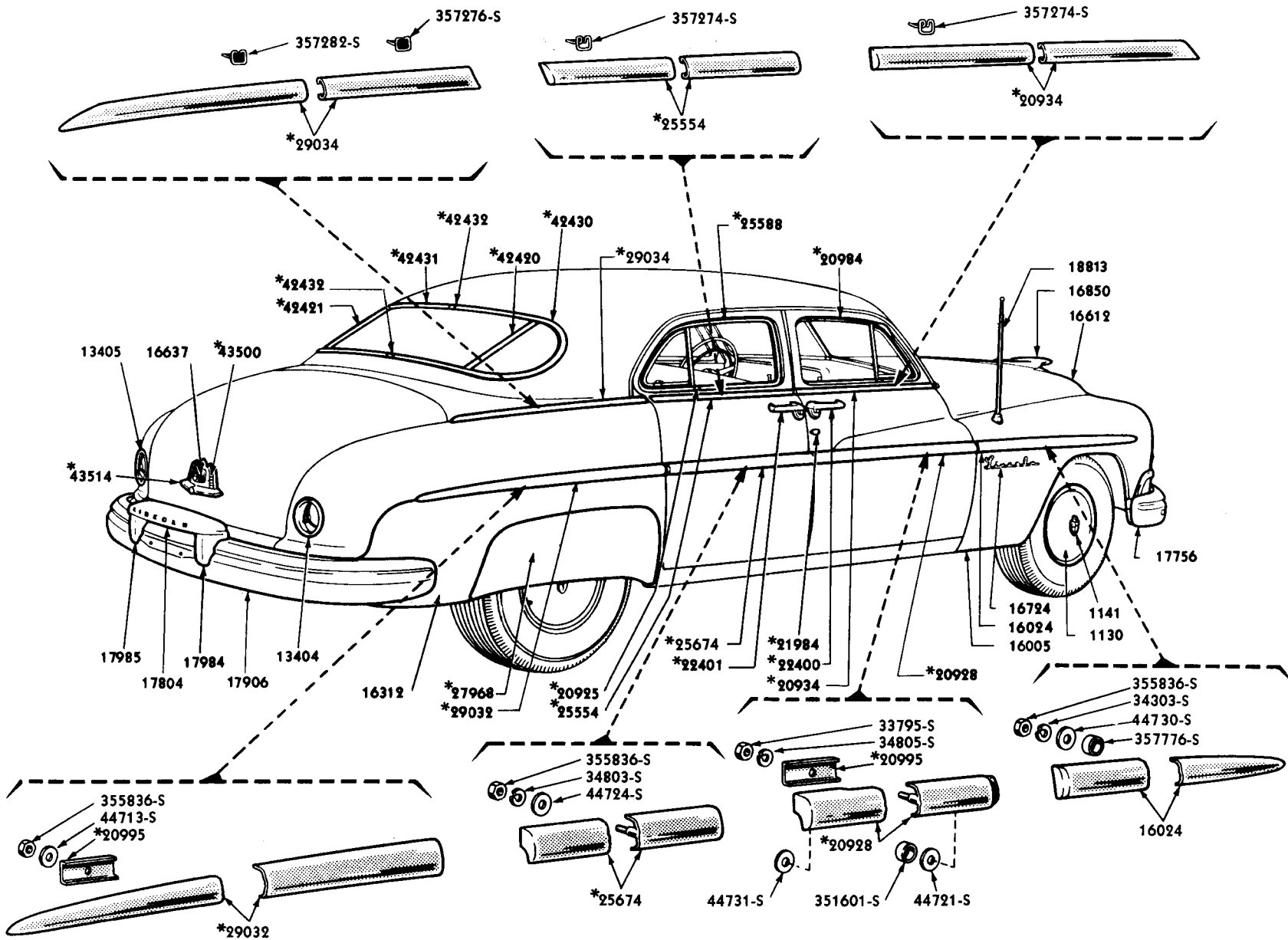

\* FOR ADDITIONAL INFORMATION REFER TO BODY PARTS LIST

**1950 LINCOLN SPORT SEDAN EXTERIOR VIEW (BODY TYPE 74)**

Group numbers only shown on illustration. Order by Part Numbers shown in list of parts.

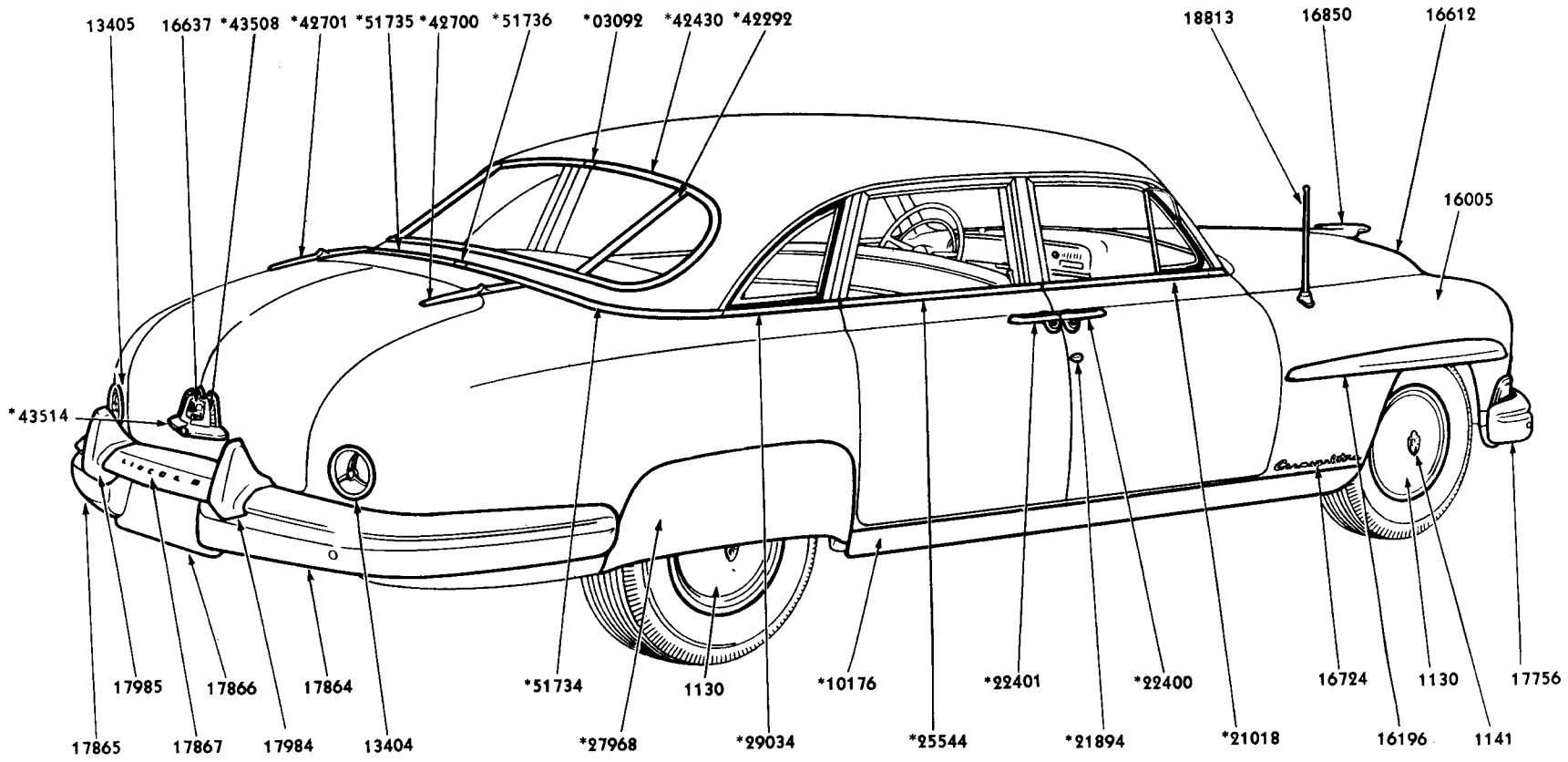

\* FOR ADDITIONAL INFORMATION REFER TO BODY PARTS LIST

PL-401

**1950 LINCOLN COSMOPOLITAN SPORT SEDAN (BODY TYPE 74)**

Group numbers only shown on illustration. Order by Part Numbers shown in list of parts.

*Lincoln and Lincoln Corporation*

CHASSIS PARTS CATALOGUE

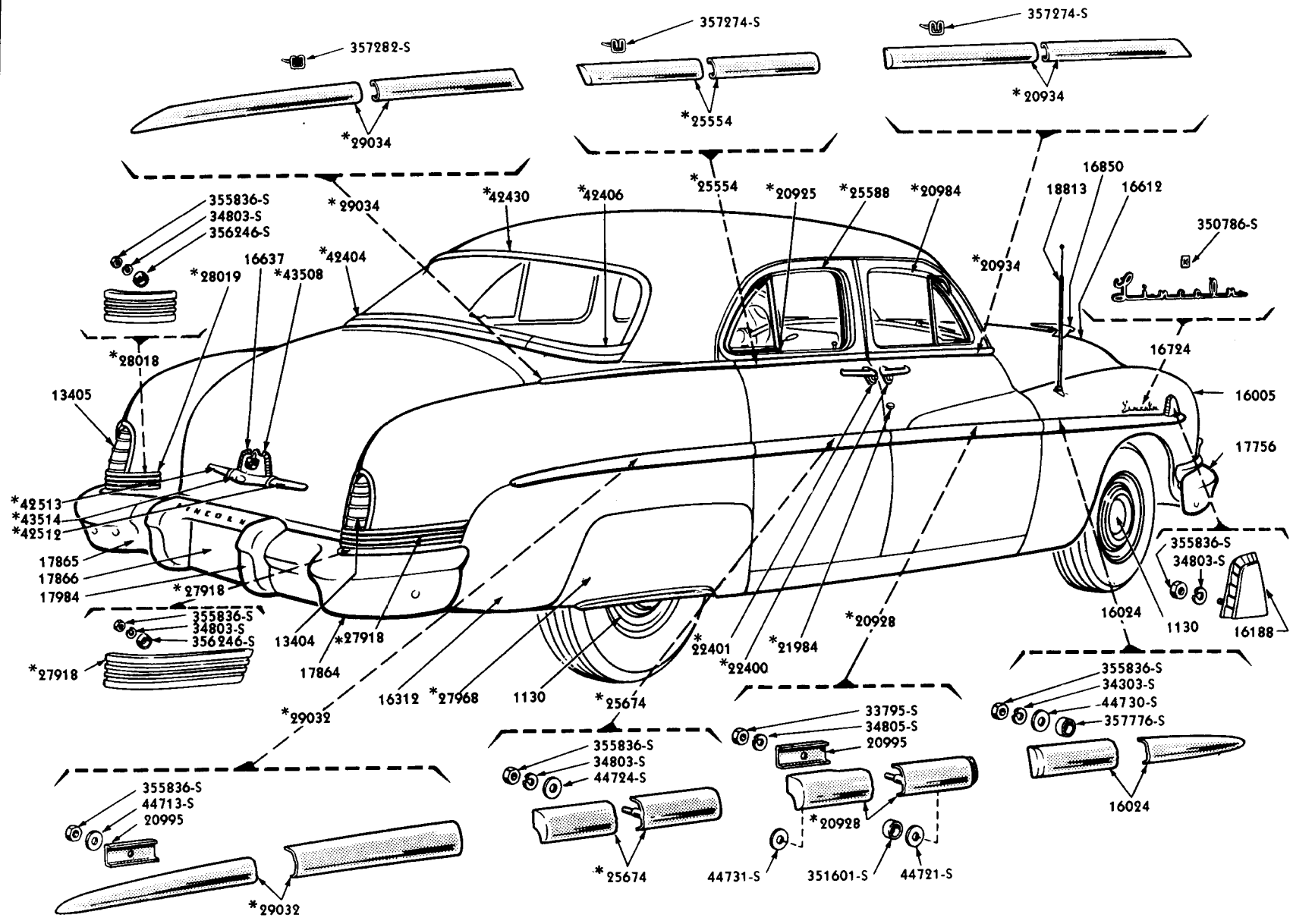

\* FOR ADDITIONAL INFORMATION REFER TO BODY PARTS LIST

PL-573

**1951 LINCOLN SPORT SEDAN EXTERIOR VIEW (BODY TYPE 74)**

Basic numbers only shown on illustration. Order by Part Numbers shown in list of parts.

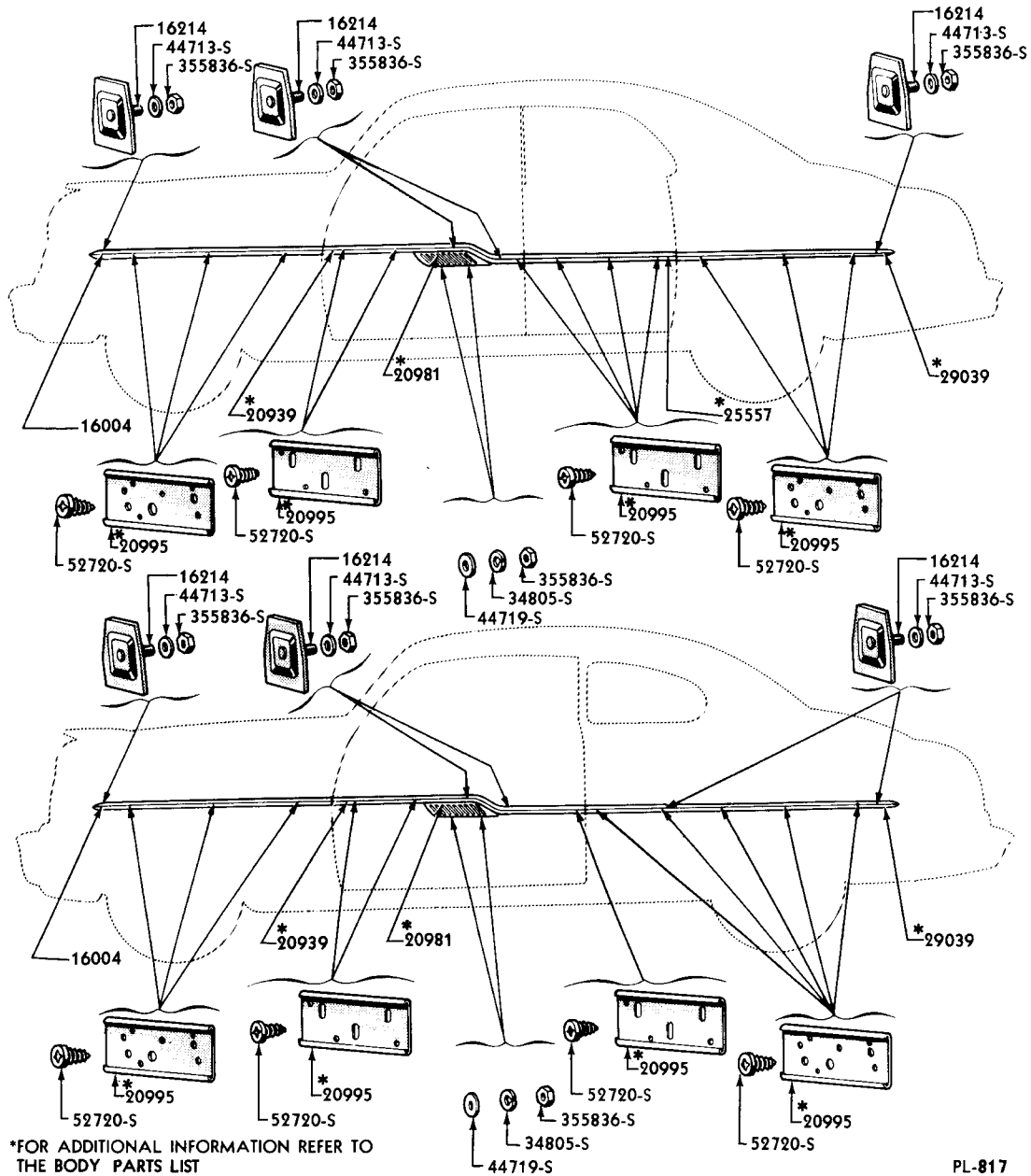

**LINCOLN STAMPED EXTERIOR MOULDINGS (BODY TYPES 72-72C-74)**

Basic numbers only shown on illustration. Order by Part Numbers shown in list of parts.

*Lincoln and Lincoln Cosmopolitan*  
CHASSIS PARTS CATALOGUE

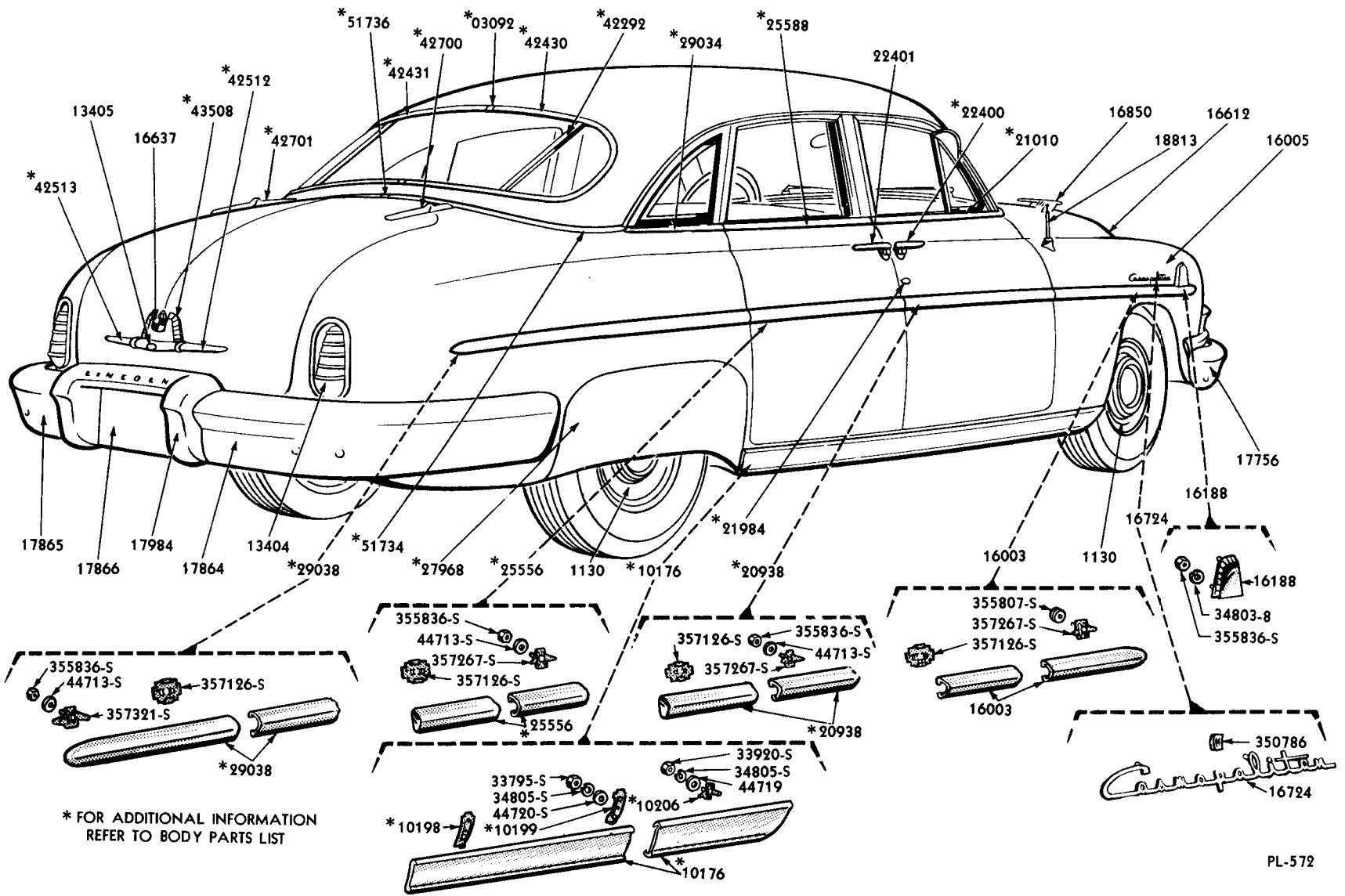

\* FOR ADDITIONAL INFORMATION  
REFER TO BODY PARTS LIST

1951 LINCOLN COSMOPOLITAN SPORT SEDAN EXTERIOR VIEW (BODY TYPE 74)

Basic numbers only shown on illustration. Order by Part Numbers shown in list of parts.

# Lincoln and Lincoln Cosmopolitan

## CHASSIS PARTS CATALOGUE

### Polishes, Cleaners, etc.

PART NUMBER	PART NAME	NO. REQ'D	MODEL	YEAR 19
BD 19512-A	Mitt (car washing)-Chenille			
1M 19514-A	Coating (Chrome)-8 oz can			
8L 19515-B	Undercoating (body)-53 gal. drum			
HACA 19517-A	Cloth (dust)-wax treated			
HACA 19517-B	Cloth (dust)-wax treated-package of (12) HACA-19517-A cloths			
8L 19520-A	Cleaner (body)-liquid-pt.			
8L 19520-D	Cleaner (body)-liquid-case of (12) pt. cans			
8L 19521-A	Cleaner (spot remover)-pt.			
8L 19521-B	Cleaner (spot remover)-gal.			
8L 19521-C	Cleaner (spot remover)-case of (12) pt. cans			
8L 19522-A	Cleaner (chrome)-pt.			
8L 19522-B	Cleaner (chrome)-case of (12) pt. cans			
8H 19523-A	Cleaner (white side wall tires)-13 oz. can			
8H 19523-B	Cleaner (white side wall tires)-case of (12) 13 oz. cans			
8L 19526-A	Cleaner (upholstery foam)-pt.			
8L 19526-C	Cleaner (upholstery foam)-case of (12) pt. cans			
8L 19528-A	Compound (body porcelainize)-liquid-8 oz. bottle			
8L 19528-C	Compound (body porcelainize)-liquid-case of (24) 8 oz. bottles			
8L 19529-A	Polish (body porcelainize)-cream-8 oz. bottle			
8L 19529-C	Polish (body porcelainize)-cream-case of (24) 8 oz. bottles			
8L 19530-A	Polish (body)-pt.			
8L 19530-C	Polish (body)-case of (12) pt. cans			
BD 19530-A	Polish (body)-Blue Coral-16.18 imperial oz.			
BD 19530-B	Polish (body)-Lectron-16 oz.			
8L 19534-A	Wax (body polishing)-8 oz. cans			
8L 19534-B	Wax (body polishing)-case of (12) 8 oz. cans			
BD 19534-A	Wax (body)-Blue Coral-80 grams			
BD 19534-B	Wax (body)-Blue Coral-227 grams			
8L 19541-A	Fluid (shock absorber)-pt.			
8L 19541-B	Fluid (shock absorber)-gal.			
8L 19541-C	Fluid (shock absorber)-case of (12) pt. cans			
HACA 19542-A	Fluid (brake)-heavy duty-pt.			
HACA 19542-B	Fluid (brake)-heavy duty-gal.			
HACA 19542-C	Fluid (brake)-heavy duty-case of (12) pt. cans			
HACA 19542-D	Fluid (brake)-heavy duty-case of (4) gal. cans			
HACA 19542-E	Fluid (brake)-heavy duty-5 gal. can			



# Lincoln and Lincoln Cosmopolitan

## CHASSIS PARTS CATALOGUE

### Polishes, Cleaners, etc.—Continued

PART NUMBER	UNIT	PART NAME	NO. REQ'D	MODEL	YEAR 19__
8H 19544		Anti-freeze-permanent-gal.			
8H 19544-B		Anti-freeze (permanent)-case of (24) qt. cans			
8M 19544-A		Anti-freeze (type N)-gal.			
8M 19544-B		Anti-freeze (type N)-54 gallon drum			
HACA 19544-A		Anti-freeze (permanent)-qt.			
8L 19545-A		Fluid (window regulator)-pt.			
8L 19545-B		Fluid (window regulator)-case of (12) pt. cans			
8H 19546-A		Inhibitor (cooling system rust)-pt.			
8H 19546-B		Inhibitor (cooling system rust)-case of (12) pt. cans			
8L 19550-A		Solution (W/S washer)-6 oz.			
8L 19550-B		Solution (W/S washer)-case of (12) 6 oz. cans			
8L 19552-A		Cement (Rubber)-5 oz.			
8L 19552-B		Cement (Rubber)-case of (12) 5 oz. tubes			
8M 19554-A		Sealer (compound)-16 oz.			
8M 19554-B		Sealer (compound)-case of (12) 16 oz. cans			
8L 19558-A		Radiator Stop Leak-10 oz.			
8L 19558-B		Radiator Stop Leak-case of (12) 10 oz. cans			
8M 19560-A		Kit (Caulking strips)-case of (8) cartons			
8M 19560-B		Kit (Caulking strip)-carton (80 ft.)			
8L 19575-A		Grease (distributor)-4 oz. tube			
8L 19575-B		Grease (distributor)-case of (12) 4 oz. tubes			
8L 19582-A		Fluid (Hydra-Matic transmission)-54 gal. drum			
8L 19582-B		Fluid (Hydra-Matic transmission)-5 gal. can			
8L 19582-C		Fluid (Hydra-Matic transmission)-1 qt. can			
8L 19582-D		Fluid (Hydra-Matic transmission)-case of (24) qt. cans			
8L 19585-A		Grease (wheel bearing)-5 lb. can			
8L 19585-B		Grease (wheel bearing)-case of (6) 5 lb. cans			
8L 19586-A		Lubriplate-waterproof-2 oz. tube			
8L 19586-B		Lubriplate-waterproof-case of (12) 2 oz. tubes			
HCCA 19587-A		Lubricant (hypoid)-rear axle break-in-35 lb. pail			

# Lincoln and Lincoln Cosmopolitan

## CHASSIS PARTS CATALOGUE

### Wheels, Hubs and Drums

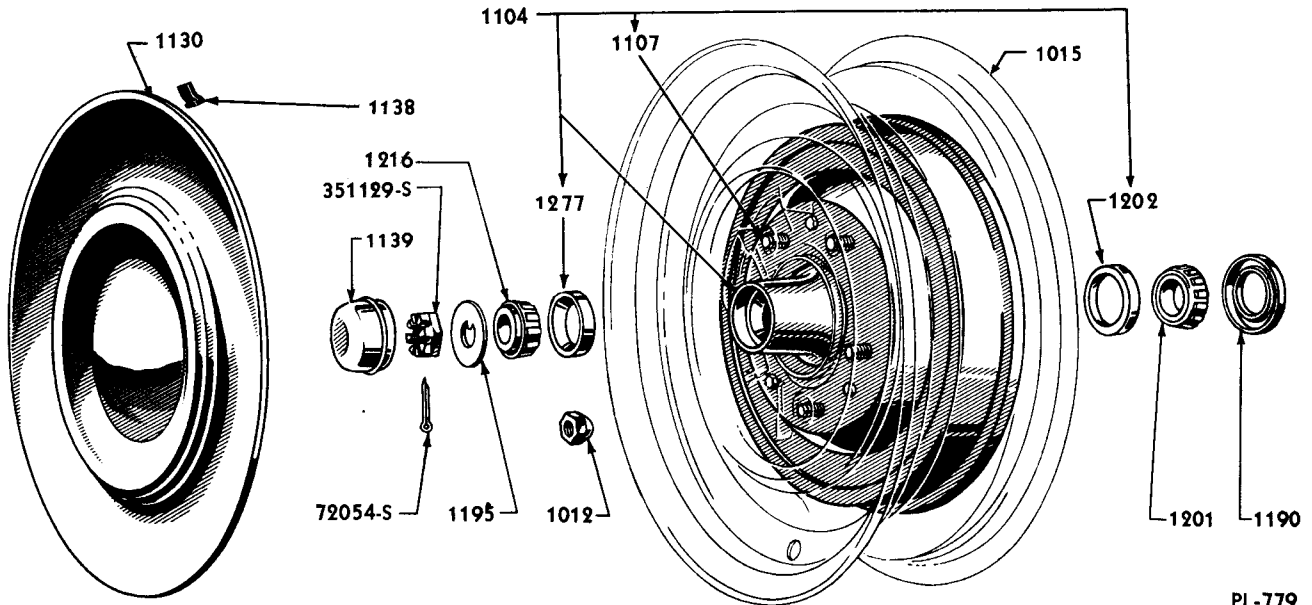

PL-779

### FRONT WHEEL HUB, BEARINGS, CAP, ETC.

Basic numbers only shown on illustration. Order by Part Numbers shown in list of parts.

PART NUMBER	QTY	PART NAME	NO. REQ'D	MODEL	YEAR
					19
		8L-19585-B Grease (wheel bearing)-5 pound can	as reqd	9L,9H,OL,OH,1L,1H	49-51
B 1012		Nut (wheel bolt)-1/2"-20	20	9L,9H,OL,OH,1L,1H	49-51
OL 1015-AP		Wheel assy-15" x 6"-in Prime	5	9L,9H,OL,OH,1L,1H	49-51
8L 1104-A		Hub & cup assy (wheel front)-with inner bearing cup 2-5/8" O.D.	2	9L,9H,OL,OH	49-50
8M 1104-A		Hub & cup assy (wheel front)-with inner bearing cup 2-23/32" O.D.	2	OL,OH,1L,1H	50-51
8L 1105		Hub and brake drum assy (front)	2	9L,9H,OL,OH,1L,1H	49-51
		24311-S8 Bolt (hex head)-5/16"-24 x 1/2"-attaches drum to hub	6	9L,9H,OL,OH,1L,1H	49-51
8M 1107		Bolt (wheel hub)-front wheels-1/2"-20 x 1-19/64"-serrated under head	10	9L,9H,OL,OH,1L,1H	49-51
IA 1107-A		Bolt (wheel hub)-rear wheel-1/2"-20 x 1-19/64"	10	9L,9H,OL,OH,1L,1H	49-51
8L 1125		Drum assy (front brake)	2	9L,9H,OL,OH,1L,1H	49-51
8L 1126		Drum assy (rear brake)	2	9L,9H,OL,OH,1L,1H	49-51
		356080-832 Nut (spring)-1/2"-20-to attach rear brake drum to rear axle	6	9L,9H,OL,OH,1L,1H	49-51
OL 1129-A		Shell (wheel hub cap)	4	9L,9H,OL,OH	49-50
8L 1130-C	NS	Cap assy (wheel hub)-replaced by (1) OL-1129-A, (1) 8L-1141 and (2) 350836-AS7	4	9L,9H	49
1L 1130-A		Cap (wheel hub)	4	1L,1H	51
1L 1137-A		Cap (wheel hub)-with two center holes for 1L-1141-A Medallion and 1L-1159-AP Disc	4	1L72C,1H72C	51
8L 1138-B		Insert (wheel hub cap)-Rubber-used with 8L-1130-C	16	9L,9H	49

# Lincoln and Lincoln Cosmopolitan

## CHASSIS PARTS CATALOGUE

PART NUMBER	QTY	PART NAME	NO. REQ'D	MODEL	YEAR
51A 1139		Cap (front hub grease)	2	9L,9H,OL,OH,1L,1H	49-51
51A 1140		Spring (brake drum silencer)	4	9L,9H,OL,OH,1L,1H	49-51
8L 1141		Medallion (wheel hub cap)-Gold Plated-1-15/16" max. width x 3-5/8" long	4	9L,9H,OL72C,OH72C	49-50
OL 1141		Medallion (wheel hub cap)-Chrome Plated-1-15/16" max. width x 3-5/8" long	4	OL,OH	50
		350836-AS7 Nut (flat type speed)-3/16" diameter hole	8	9L,9H,OL,OH	49-50
1L 1141-A	NS	Medallion (wheel hub cap)-Gold Plated-2-9/16" max. width x 2-19/64" long-serviced in HBK-1141-A Kit	4	1L72C,1H72C	51
		355914-S32 Nut (spring)-No. 10 (3/8" x 5/8")	8	1L72C,1H72C	51
HBK 1141-A		Kit (medallion installation wheel hub cap)-consists of the following (1) 1L-1141-A Medallion (2) 355914-S32 Nut	4	1L72C,1H72C	51
1L 1159-AP		Disc (wheel hub cap ornament)-6" dia.-convex-in prime	4	1L72C,1H72C	51
OM 1177-A		Seal assy (wheel bearing inner oil)-1/4" thick	2	9L,9H,OL,OH,1L,1H	49-51
8M 1180		Retainer (rear wheel bearing)-inner	2	9L,9H,OL,OH,1L,1H	49-51
8M 1190		Grease retainer assy (front wheel)	2	9L,9H,OL,OH,1L,1H	49-51
B 1195		Washer (front hub bearing retainer)-3/4" I.D. x 1-13/16" O.D. x 3/32" thick, with lug for keyway	2	9L,9H,OL,OH,1L,1H	49-51
8L 1201		Cone and roller assy (front wheel)-inner-used with 8L-1104-A and 8L-1105	2	9L,9H,OL,OH	49-50
OLY 1201		Cone & roller assy (front wheel)-inner-used with 8M-1104-A assy	2	OL,OH,1L,1H	50-51
9L 1202		Cup (front wheel bearing)-inner-2-5/8" O.D.-used 8L-1104-A and 8L-1105	2	9L,9H,OL,OH	49-50
OLY 1202		Cup (front wheel bearing)-inner-2-23/32" O.D.-used with 8M-1104-A	2	OL,OH,1L,1H	50-51
8M 1216		Cone and roller assy (front wheel)-outer	2	9L,9H,OL,OH,1L,1H	49-51
8M 1217		Cup (front wheel bearing)-outer	2	9L,9H,OL,OH,1L,1H	49-51
8M 1225-B		Bearing (rear wheel)	2	9L,9H,OL,OH,1L,1H	49-51

### Spare Wheel Clamps

11A 1446		Clamp (spare wheel and tire)	1	9L,OL,1L	49-51
8M 1447		Bolt (spare wheel carrier)	1	1L	51
		B-1012 Nut (spare wheel clamp)-1/2"-20	1	9L,OL,1L	49-51
		8M-7247070 Bracket assy (luggage compartment spare wheel mounting)	1	9L	49
		OL-7247070 Bracket assy (luggage compartment spare wheel mounting)	1	OL,1L	50-51
		8H-7347074-A Clamp (spare wheel and tire)-with-out slot at lower end	1	9H	49
		8H-7347074-B Clamp (spare wheel and tire)-with slot at lower end	1	9H,OH,1H	49-51
		350815-S7 Bolt (hex-hd)-1/2"-13 x 2-7/8"	1	9H,OH,1H	49-51

# Lincoln and Lincoln Cosmopolitan

## CHASSIS PARTS CATALOGUE

PART NUMBER	QTY	PART NAME	NO. REQ'D	MODEL	YEAR 19__
<b>Service Brakes</b>					
	NS	HACA-19542-A Fluid (brake)-heavy duty-pt.- replaced by HACA-19542-C	as reqd	9L,9H,OL,OH,1L,1H	49-51
		HACA-19542-B Fluid (brake)-heavy duty-gallon	as reqd	9L,9H,OL,OH,1L,1H	49-51
		HACA-19542-C Fluid (brake)-heavy duty-case- consists of (12) 1 pt. containers	as reqd	9L,9H,OL,OH,1L,1H	49-51
★8L 2001-A	NS	Kit (front brake shoe & lining)-.202"/.222" lining thickness unplated shoes-replaced by 1 each 8L-2001-C, 8L-2200-C Kits	1	9L,9H	49
★★8L 2001-B	NS	Kit (front brake shoe & lining)-with .202"/.222" lining thickness-zinc plated shoes-replaced by 1 each 8L-2001-C, 8L-2200-C Kits	1	9L,9H	49
●8L 2001-C		Kit (front brake shoe & lining)-.182"/.192" thick lining-with short primary lining-consists of the following (2) 8L-2018-D Shoe & lining (front brake)-primary (2) 8L-2019-B Shoe & lining (front brake)-secondary	1	9L,9H,OL,OH	49-50
OL 2001		Kit (brake shoe & lining)-complete car-marked with (2) white paint stripes-consists of the following (2) 8L-2018-D Shoe & lining-front-primary (2) 8L-2218-D Shoe & lining-rear-primary (2) OL-2019-B Shoe & lining-front-secondary (2) OL-2219-B Shoe & lining-rear-secondary	1	9L,9H,OL,OH,1L,1H	49-51
HAK 2001-A		Kit (front brake shoe & lining)-.182"/.192" thick lining-Standard-Axle Set-consists of the following (2) 8L-2018-D Shoe & lining-front primary (2) OL-2019-B Shoe & lining-front secondary	1	9L,9H,OL,OH,1L,1H	49-51
8M 2004		Kit (brake master cylinder repair)-consists of the following (2) 8M-2152 Gasket (1) 51A-2169 Piston (1) 51A-2173 Cup (1) 51A-2174 Snap ring (1) 51A-2178 Valve (1) 91A-2180-A Boot	1	9L,9H,OL,OH,1L,1H	49-51
★8L 2007-A		Kit (front brake lining)-.202"/.222" thick-consists of the following (2) 8L-2021-A Lining (2) 8L-2022-A Lining (45) 351939-S Rivet	1	9L,9H	49
●8L 2007-B		Kit (front brake lining)-.182"/.192" thick-consists of the following (2) 8L-2021-B Lining (2) 8L-2022-B Lining (45) 351939-S Rivet	1	9L,9H	49
★8L 2007-C		Kit (front brake lining)-.182"/.192" thick-with short primary lining-consists of the following (2) 8L-2021-D Lining (2) 8L-2022-B Lining (45) 351939-S Rivet	1	9L,9H,OL,OH,1L,1H	49-51

★ Used with 8L-2200-A Kit

★★ Used with 8L-2200-B Kit

● Used with 8L-2200-C Kit

★★ Used with 8L-2222-A Kit

●● Used with 8L-2222-B Kit

★● Used with 8L-2222-C Kit

# Lincoln and Lincoln Cosmopolitan

## CHASSIS PARTS CATALOGUE

### Service Brakes—Continued

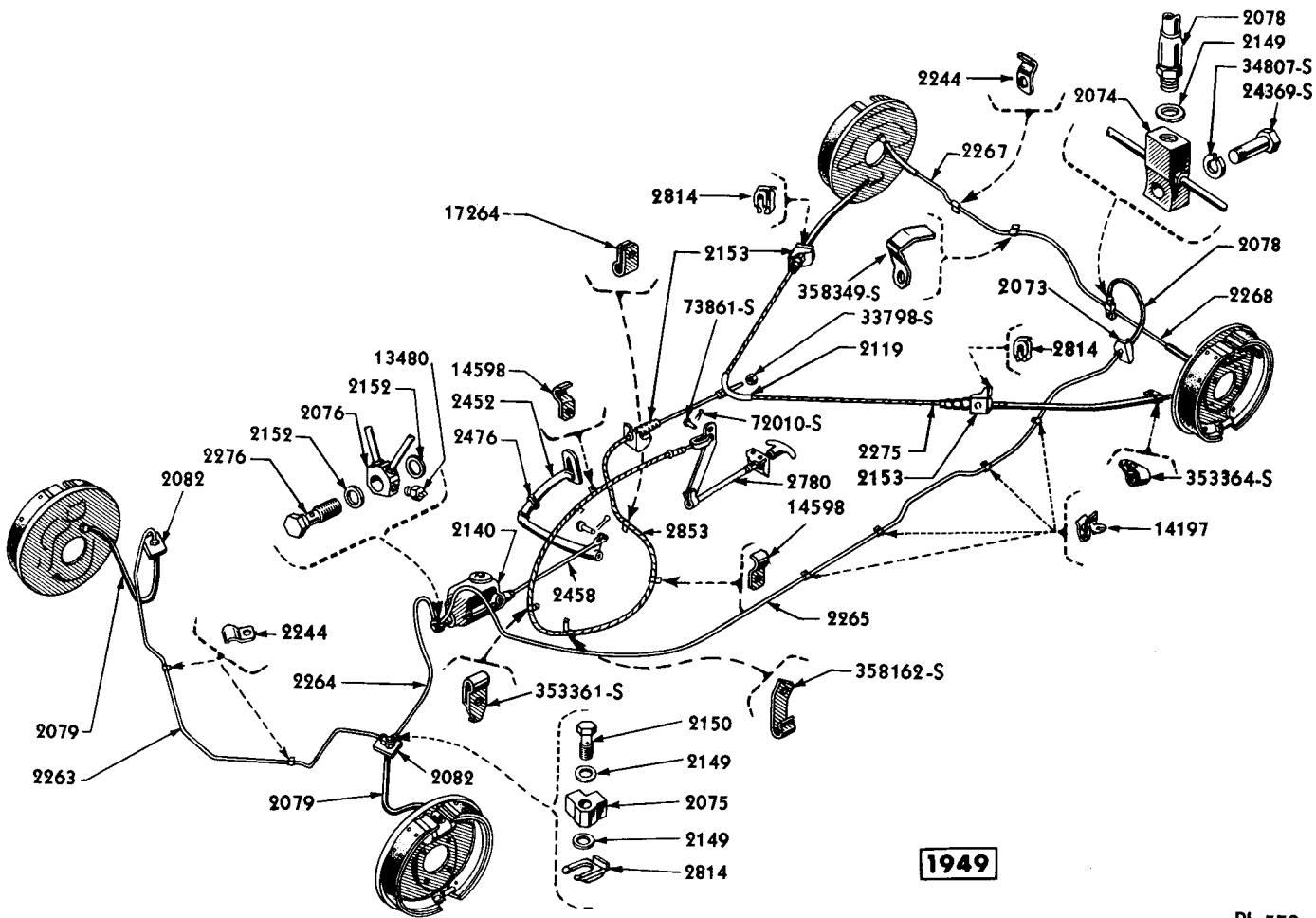

PL-578

### BRAKE SYSTEM

Basic numbers only shown on illustration. Order by Part Numbers shown in list of parts.

PART NUMBER	PART NAME	NO. REQ'D	MODEL	YEAR
6L 2007	Kit (brake lining)-complete car-marked with (2) White paint stripes-consists of the following (2) 8L-2021-D Lining-front-primary (2) 8L-2284-D Lining-rear-primary (2) 0L-2022-B Lining-front-secondary (2) 0L-2285-B Lining-rear-secondary (88) 351939-S Rivet	1	9L,9H,0L,0H,1L,1H	19 49-51
HAK 2007-A	Kit (front brake lining)-.182"/.192" thick-Standard-Axle Set-consists of the following (2) 8L-2021-D Lining-front primary (2) 0L-2022-B Lining-front secondary (40) 351939-S Rivet (flat-hd-9/64" x 1/4")	1	9L,9H,0L,0H,1L,1H	49-51
8L-22009	Kit (brake spring repair)-consists of the following (4) 96H-2036 Spring (8) 6H-2066 Cup (4) H-2068 Spring (4) 8L-2069 Pin (2) H-2092 Plate	1	9L,9H,0L,0H,1L,1H	49-51

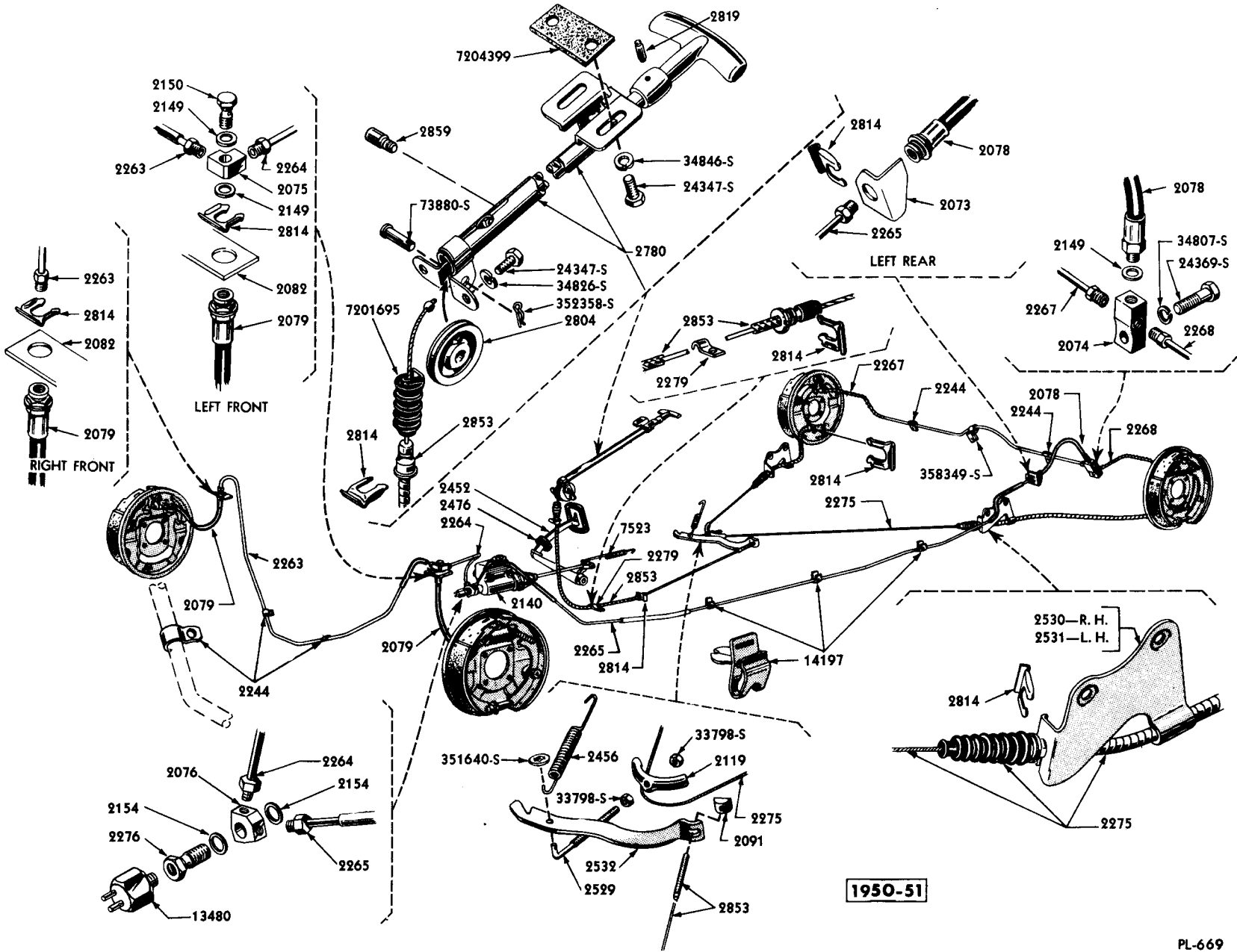

**BRAKE SYSTEM**

Basic numbers only shown on illustration. Order by Part Numbers shown in list of parts.

PL-669

# Lincoln and Lincoln Cosmopolitan

## CHASSIS PARTS CATALOGUE

### Service Brakes—Continued

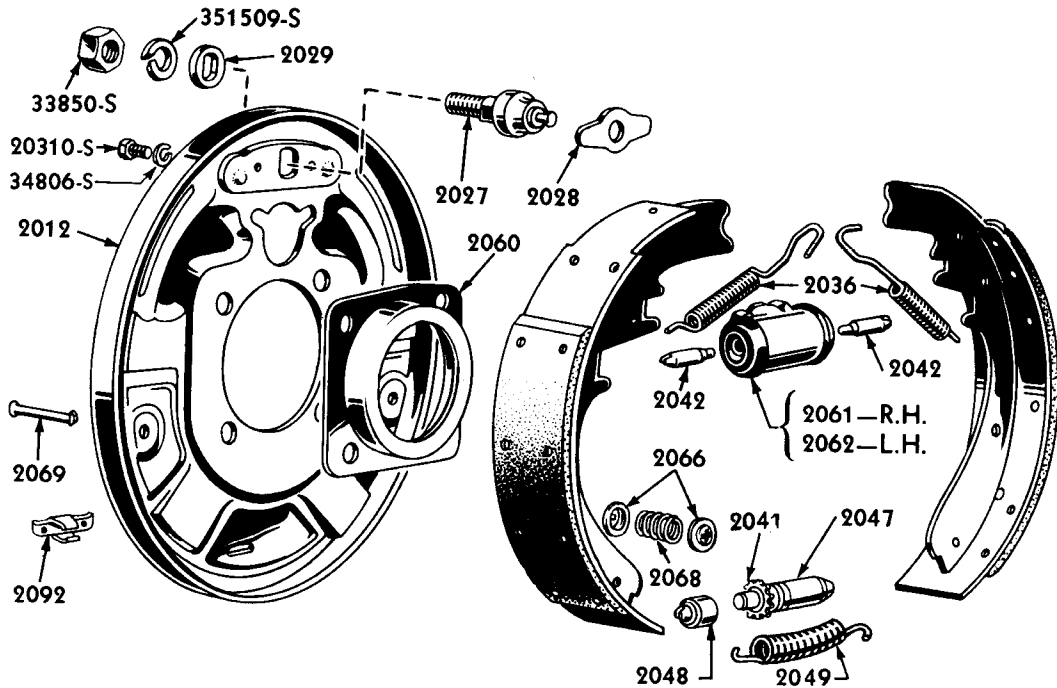

PL-780

### FRONT BRAKES

Basic numbers only shown on illustration. Order by Part Numbers shown in list of parts.

PART NUMBER	QTY	PART NAME	NO. REQ'D	MODEL	YEAR 19__
8L 2010		Brake assy (front)-R.H.	1	9L,9H,OL,OH	49-50
OL 2010		Brake assy (front)-R.H.-marked with (2) White paint stripes-use only in sets-OL-2010 and OL-2011	1	9L,9H,OL,OH,1L,1H	49-51
8L 2011		Brake assy (front)-L.H.	1	9L,9H,OL,OH	49-50
OL 2011		Brake assy (front)-L.H.-marked with (2) White paint stripes-use only in sets-OL-2010 and OL-2011	1	9L,9H,OL,OH,1L,1H	49-51
8L 2012-A	NS	Plate assy (front brake backing)-unpainted-replaced by 8L-2012-B	2	9L,9H,OL,OH	49-50
8L 2012-B		Plate assy (front brake backing)-painted	2	9L,9H,OL,OH,1L,1H	49-51
		8M-2056 Bolt (front brake housing)-rear lower-1/2"-20 x 3-1/8"-with pilot end	2	9L,9H,OL,OH,1H	49-51
		OL-2056-A Bolt (front brake backing plate)-rear lower-1/2"-20 x 3-11/64"	2	1L	51
		355653-S8 Bolt (hex head)-1/2"-20 x 1-7/8"-to spindle-lower front	2	9L,9H,OL,OH,1L,1H	49-51
		355692-S Bolt (hex head)-1/2"-20 x 1-1/8"-to spindle-upper	4	9L,9H,OL,OH,1L,1H	49-51
		72035-S7 Cotter pin-1/8" x 1"-lower	4	9L,9H,OL,OH,1L,1H	49-51
		34399-S8 Locknut (hex)-1/2"-20-plate to spindle-upper front & upper rear	4	9L,9H,OL,OH,1L,1H	49-51
		34032-S7 Nut (castle)-1/2"-20-lower	4	9L,9H,OL,OH,1L,1H	49-51
96H 2027		Pin (brake shoe anchor)	4	9L,9H,OL,OH,1L,1H	49-51
		351509-S7 Lockwasher-5/8"	4	9L,9H,OL,OH,1L,1H	49-51
		33850-S2 Nut (hex)-5/8"-18	4	9L,9H,OL,OH,1L,1H	49-51

# Lincoln and Lincoln Cosmopolitan

## CHASSIS PARTS CATALOGUE

PART NUMBER	QUANTITY	PART NAME	NO. REQ'D	MODEL	YEAR
<b>Service Brakes—Continued</b>					
96H 2028		Plate (brake shoe anchor pin guide)	4	9L, 9H, OL, OH, 1L, 1H	49-51
96H 2029		Washer (brake shoe anchor pin to backing plate)-.661"/.666" and .682"/.687" I.D. x 1-1/16" and 1-3/16" O.D.	4	9L, 9H, OL, OH, 1L, 1H	49-51
96H 2036	NS	Spring (brake shoe retracting)-replaced by 8L-22009-approximate overall free length 5-1/2"	8	9L, 9H, OL, OH, 1L, 1H	49-51
H 2041		Screw (brake adjusting)-1/2"-20 x 2-1/2" overall length	4	9L, 9H, OL, OH, 1L, 1H	49-51
8M 2042		Link (brake shoe connecting)	8	9L, 9H, OL, OH, 1L, 1H	49-51
8M 2047		Nut (brake adjusting screw pilot)-with three grooves on O.D.	4	9L, 9H, OL, OH, 1L, 1H	49-51
8M 2048		Socket (brake adjusting screw)	4	9L, 9H, OL, OH, 1L, 1H	49-51
8M 2049		Spring (brake adjusting screw)	4	9L, 9H, OL, OH, 1L, 1H	49-51
8M 2056		Bolt (front brake housing)-rear lower-pilot end-1/2"-20 x 3-1/8"	2	9L, 9H, OL, OH, 1H	49-51
OL 2056-A		Bolt (front brake backing plate)-rear lower-1/2"-20 x 3-11/64"	2	1L	51
		72035-S7 Cotter pin-1/8" x 1"	2	9L, 9H, OL, OH, 1L, 1H	49-51
		34032-S7 Nut (castle)-1/2"-20-rear lower	2	9L, 9H, OL, OH, 1L, 1H	49-51
8M 2060		Baffle (front brake grease)	2	9L, 9H, OL, OH, 1L, 1H	49-51

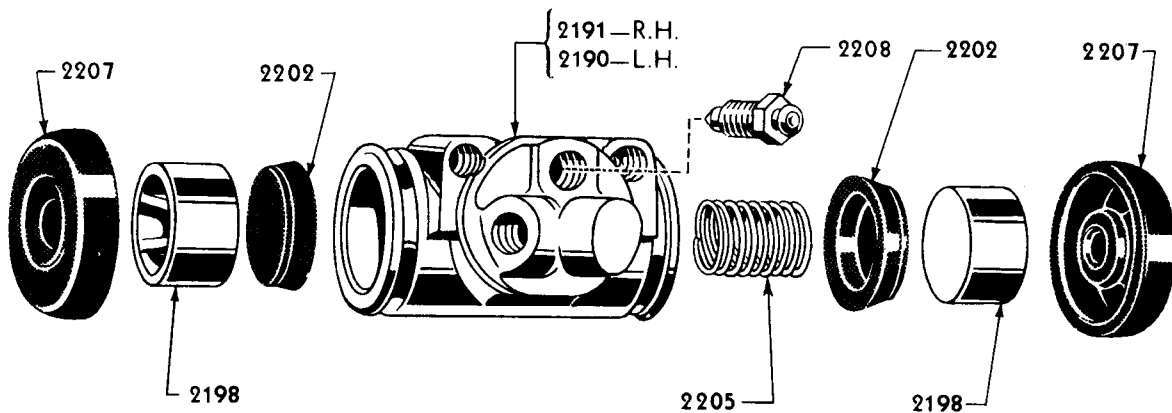

PM-579

### FRONT WHEEL BRAKE CYLINDER

Basic numbers only shown on illustration. Order by Part Numbers shown in list of parts.

8M 2061-A	Cylinder assy (front brake)-RH-1-1/8" diameter	1	9L, 9H, OL, OH, 1L, 1H	49-51
8M 2062-A	Cylinder assy (front brake)-LH-1-1/8" diameter	1	9L, 9H, OL, OH, 1L, 1H	49-51
	20310-S2 Bolt (hex head)-5/16"-18 x 1/2"	4	9L, 9H, OL, OH, 1L, 1H	49-51
	34806-S7 Lockwasher-5/16"	4	9L, 9H, OL, OH, 1L, 1H	49-51
	8M-2221 Kit (front wheel brake cyl. repair) -consists of the following (2) 91A-2202 Cup (2) OM-2207-A Boot	2	9L, 9H, OL, OH, 1L, 1H	49-51
6H 2066	Cup (brake shoe hold down spring)-serviced in 8L-22009	16	9L, 9H, OL, OH, 1L, 1H	49-51



# Lincoln and Lincoln Cosmopolitan

## CHASSIS PARTS CATALOGUE

PART NUMBER	COND.	PART NAME	NO. REQ'D	MODEL	YEAR 19__
<b>Service Brakes—Continued</b>					
H 2068		Spring (brake shoe hold down)-23/32" O.D. x 1-1/16" overall free length-serviced in 8L-22009	8	9L,9H,OL,OH,1L,1H	49-51
8L 2069	NS	Pin (brake shoe hold down spring)-repl. by 8L-22009	8	9L,9H,OL,OH,1L,1H	49-51
8M 2073		Bracket (brake hose)-rear	1	9L,9H,OL,OH,1L,1H	49-51
8M 2074		Connector (rear brake line)-has (1) 3/8"-24 tapped hole and (1) 25/64" straight hole	1	9L,9H,OL,OH,1L,1H	49-51
		8M-2149 Gasket (rear brake line connector)-Copper-25/64" I.D. x 5/8" O.D. x 1/16" thick	1	9L,9H,OL,OH,1L,1H	49-51
		24369-S8 Bolt (hex head)-3/8"-24 x 7/8"	1	9L,9H,OL,OH,1L,1H	49-51
		34807-S2 Lockwasher-3/8"	1	9L,9H,OL,OH,1L,1H	49-51
8A 2075		Connector (front brake line)-has (2) 3/8"-24 tapped holes	1	9L,9H,OL,OH,1L,1H	49-51
		8M-2149 Gasket (front brake line connector)-Copper-25/64" I.D. x 5/8" O.D. x 1/16" thick	2	9L,9H,OL,OH,1L,1H	49-51
		8M-2150 Bolt (front brake line connector)-3/8"-24 x 1-1/16" overall length	1	9L,9H,OL,OH,1L,1H	49-51
8L 2076		Fitting (brake master cylinder outlet)-has (1) 1/8" pipe tapped hole and (2) 3/8"-24 tapped holes	1	9L,9H,OL,OH,1L,1H	49-51
		91T-2154 Gasket (brake master cylinder outlet)	2	9L,9H,OL,OH,1L,1H	49-51
		8L-2276 Bolt (brake master cylinder outlet connection)-1/2"-20 x 1-5/8" overall length	1	9L,9H,OL,OH,1L,1H	49-51
8M 2078		Hose assy (rear brake)-18-1/64" overall length	1	9L,9H,OL,OH,1L,1H	49-51
		78-2814-A Clip (rear brake hose to frame bracket)	1	9L,9H,OL,OH,1L,1H	49-51
8M 2079		Hose assy (front brake)-15-27/64" overall length	2	9L,9H,OL,OH,1L,1H	49-51
		8M-2149 Gasket (front brake hose assy to brake cyl.)-25/64" I.D. x 5/8" O.D. x 1/16" thick	2	9L,9H,OL,OH,1L,1H	49-51
		78-2814-A Clip (front brake hose to frame bracket)-"U" shaped	2	9L,9H,OL,OH,1L,1H	49-51
8M 2082		Bracket (brake hose front)	2	9L,9H,OL,OH,1L,1H	49-51
8A 2091		Nut (hand brake equalizer lever)-5/16"-24-equalizer lever to front cable assy	1	OL,OH,1L,1H	50-51
H 2092		Cover (brake adjusting hole)-serviced in 8L-22009 Kit	4	9L,9H,OL,OH,1L,1H	49-51
8L 2103		Lever assy (parking brake operating)-RH	1	9L,9H,OL,OH,1L,1H	49-51
8L 2104		Lever assy (parking brake operating)-LH	1	9L,9H,OL,OH,1L,1H	49-51
91A 2106		Retainer (rear brake emergency lever pin)	2	9L,9H,OL,OH,1L,1H	49-51
8L 2108		Strut (parking brake)	2	9L,9H,OL,OH,1L,1H	49-51
8M 2119		Equalizer (hand brake cable)	1	9L,9H,OL,OH,1L,1H	49-51
8L 2128		Kit (rear wheel brake cylinder repair)-consists of the following (2) 8L-2201 Cup (2) 96H-2206 Boot	2	9L,9H,OL,OH,1L,1H	49-51
51A 2132		Washer (emergency lever anti rattle spring)-3/8" I.D. x 3/4" O.D. x 1/64" thick	2	9L,9H,OL,OH	49-50

# Lincoln and Lincoln Cosmopolitan

## CHASSIS PARTS CATALOGUE

PART NUMBER	PART NAME	NO. REQ'D	MODEL	YEAR
-------------	-----------	-----------	-------	------

### Service Brakes—Continued

	351467-S Washer (spring)-parking brake anti rattle-3/8" I.D. x 25/32" O.D. x 1/64" thick	2	9L,9H,0L,0H,1L,1H	49-51
8L 2135-A	Housing and tube seat assy (rear brake cylinder)-RH	1	9L,9H,0L,0H,1L,1H	49-51
8L 2136-A	Housing and tube seat assy (rear brake cylinder)-LH	1	9L,9H,0L,0H,1L,1H	49-51
96H 2139-B	Spring (parking brake strut to shoe)-1-9/32" overall free length oblong shaped	2	9L,9H,0L,0H,1L,1H	49-51

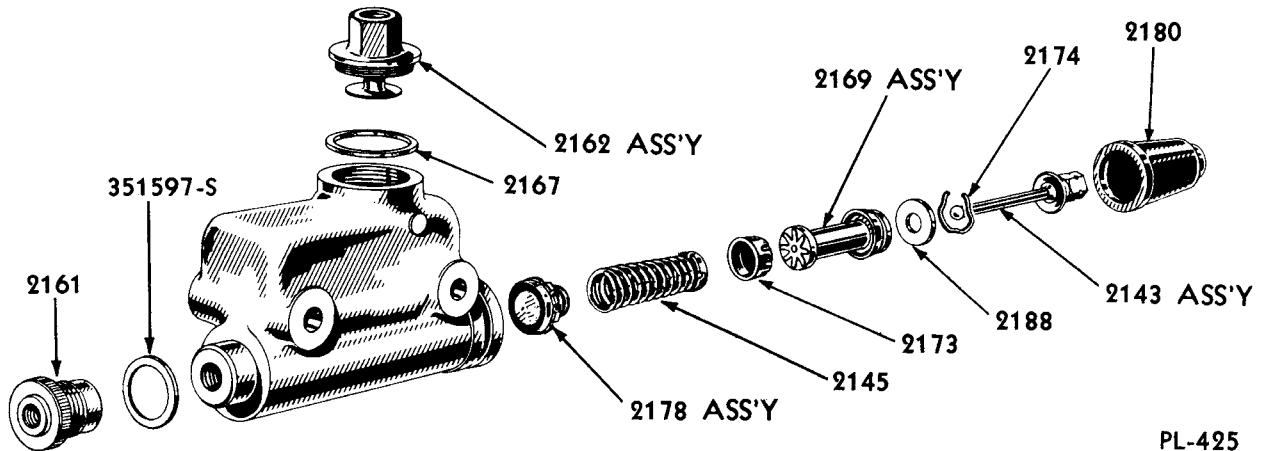

PL-425

### MASTER BRAKE CYLINDER

Basic numbers only shown on illustration. Order by Part Numbers shown in list of parts.

	8M-2004 Kit (brake master cyl. repair)- consists of the following	1	9L,9H,0L,0H,1L,1H	49-51
	(2) 8M-2152 Gasket (1) 51A-2169 Piston			
	(1) 51A-2173 Cup (1) 51A-2174 Snap ring			
	(1) 51A-2178 Valve (1) 9LA-2180-A Boot			
8M 2140-A	Cylinder assy (brake master)-1" diameter	1	9L,9H,0L,0H,1L,1H	49-51
	21556-S7 Bolt (hex-hd)-3/8"-24 x 3-1/4"	2	9L,9H,0L,0H,1L,1H	49-51
	34807-S2 Lockwasher-3/8"	2	9L,9H,0L,0H,1L,1H	49-51
	91A-13480 Switch assy (stop light)	1	9L,9H,0L,0H,1L,1H	49-51
8M 2143-A	Link assy (brake master cylinder)-to brake pedal	1	9L,9H,0L,0H,1L,1H	49-51
	33798-S8 Nut (hex)-5/16"-24	2	9L,9H,0L,0H,1L,1H	49-51
8A 2145	Spring & retainer assy (brake master cylinder return)	1	9L,9H,0L,0H,1L,1H	49-51
8M 2149	Gasket (front brake line connector)-Copper- 25/64" I.D. x 5/8" O.D. x 1/16" thick	5	9L,9H,0L,0H,1L,1H	49-51
8M 2150	Bolt (front brake line connector)-3/8"-24 thread x 1-1/16" overall length	1	9L,9H,0L,0H,1L,1H	49-51
8M 2152	NS Gasket (brake master cylinder outlet)-replaced by 91I-2154	2	9L,9H,0L,0H,1L,1H	49-51
8M 2153-A	Bracket (hand brake cable)-front and rear-with 13/32" diameter hole	1or3	9L,9H	49

# Lincoln and Lincoln Cosmopolitan

## CHASSIS PARTS CATALOGUE

PART NUMBER	QTY	PART NAME	NO. REQ'D	MODEL	YEAR
<b>Service Brakes—Continued</b>					
8M 2153-B		Bracket (hand brake cable)-rear-weld on type	2	OH, 1H	50-51
8L 2153		Bracket (hand brake cable)-front-bolt on type	1	9L	49
8H 2153		Bracket (hand brake cable)-front-45° angle-weld on type	1	OH, 1H	50-51
		24389-S8 Bolt (hex-hd)-3/8"-24 x 7/8"	1	9L, 9H	49
		34445-S7 Locknut (hex)-3/8"-24	1	9L, 9H	49
91T 2154		Gasket (brake master cylinder outlet)-Copper-1/2" I.D. x 11/16" O.D. x 1/32" thick	2	9L, 9H, OL, OH, 1L, 1H	49-51
8A 2161		Plug (brake master cylinder bore)-front end of master cylinder-1/2"-20 tapped hole-1-3/32"-18 threads and knurled head	1	9L, 9H, OL, OH, 1L, 1H	49-51
		351597-S Gasket (brake master cylinder bore plug)-Copper-1-1/8" I.D. x 1-3/8" O.D. x 1/16" thick	1	9L, 9H, OL, OH, 1L, 1H	49-51
8M 2162-A		Cap assy (brake master cylinder filler)-with square head-1-5/8"-18 thread	1	9L, 9H	49
8M 2162-B		Cap assy (brake master cylinder filler)-with hex-hd -1-5/8"-18 thread	1	9L, 9H, OL, OH, 1L, 1H	49-51
8M 2167		Gasket (brake master cylinder filler cap)-Fibre-41/64" I.D. x 1-7/8" O.D. x 1/16" thick	1	9L, 9H, OL, OH, 1L, 1H	49-51
51A 2169		Piston assy (brake master cylinder)	1	9L, 9H, OL, OH, 1L, 1H	49-51
51A 2173		Cup (brake master cylinder)-primary	1	9L, 9H, OL, OH, 1L, 1H	49-51
51A 2174		Snap ring (brake master cylinder piston)-1-25/64" irregular O.D. and open end	1	9L, 9H, OL, OH, 1L, 1H	49-51
51A 2178		Valve assy (brake master cylinder)	1	9L, 9H, OL, OH, 1L, 1H	49-51
91A 2180-A		Boot (brake master cylinder)-Rubber	1	9L, 9H, OL, OH, 1L, 1H	49-51
91A 2180-B		Boot (brake master cylinder)-Rubber	1	9L, 9H, OL, OH, 1L, 1H	49-51
91A 2185		Retainer (brake master cylinder return spring)-with 4 notches on O.D.	1	9L, 9H, OL, OH	49-50
51A 2188		Plate (brake master cylinder piston stop)	1	9L, 9H, OL, OH, 1L, 1H	49-51
8M 2190-A	NS	Housing (front brake cylinder)-RH-serviced in 8M-2061-A	1	9L, 9H, OL, OH, 1L, 1H	49-51
8M 2191-A	NS	Housing (front brake cylinder)-LH-serviced in 8M-2062-A	1	9L, 9H, OL, OH, 1L, 1H	49-51
8L 2197-A		Piston (rear wheel brake cylinder)-15/16" diameter	4	9L, 9H, OL, OH, 1L, 1H	49-51
96H 2198-A		Piston (front wheel brake cylinder)-1-1/8" diameter	4	9L, 9H, OL, OH, 1L, 1H	49-51
● 8L 2200-A		Kit (rear brake shoe & lining)-.202"/.222" thickness lining-consists of the following (2) 8L-2218-A Shoe & lining (rear brake)-primary (2) 8L-2219-A Shoe & lining (rear brake)-secondary	1	9L, 9H	49
8L 2200-B	NS	Kit (rear brake shoe & lining)-.182"/.192" thick lining-replaced by (1) each 8L-2200-C and 8L-2001-C Kits	1	9L, 9H	49
●● 8L 2200-C		Kit (rear brake shoe & lining)-.182"/.192" thick lining-with short primary lining-consists of the following (2) 8L-2218-D Shoe & lining (rear brake)-primary (2) 8L-2219-B Shoe & lining (rear brake)-secondary	1	9L, 9H, OL, OH	49-50
HAK 2200-A		Kit (rear brake shoe & lining)-.182"/.192" thick lining-Standard-Axle Set-consists of the following (2) 8L-2218-D Shoe & lining-rear primary (2) OL-2219-B Shoe & lining-rear secondary	1	9L, 9H, OL, OH, 1L, 1H	49-51

● Used with 8L-2001-A Kit

●● Used with 8L-2001-C Kit

# Lincoln and Lincoln Cosmopolitan

## CHASSIS PARTS CATALOGUE

### Service Brakes—Continued

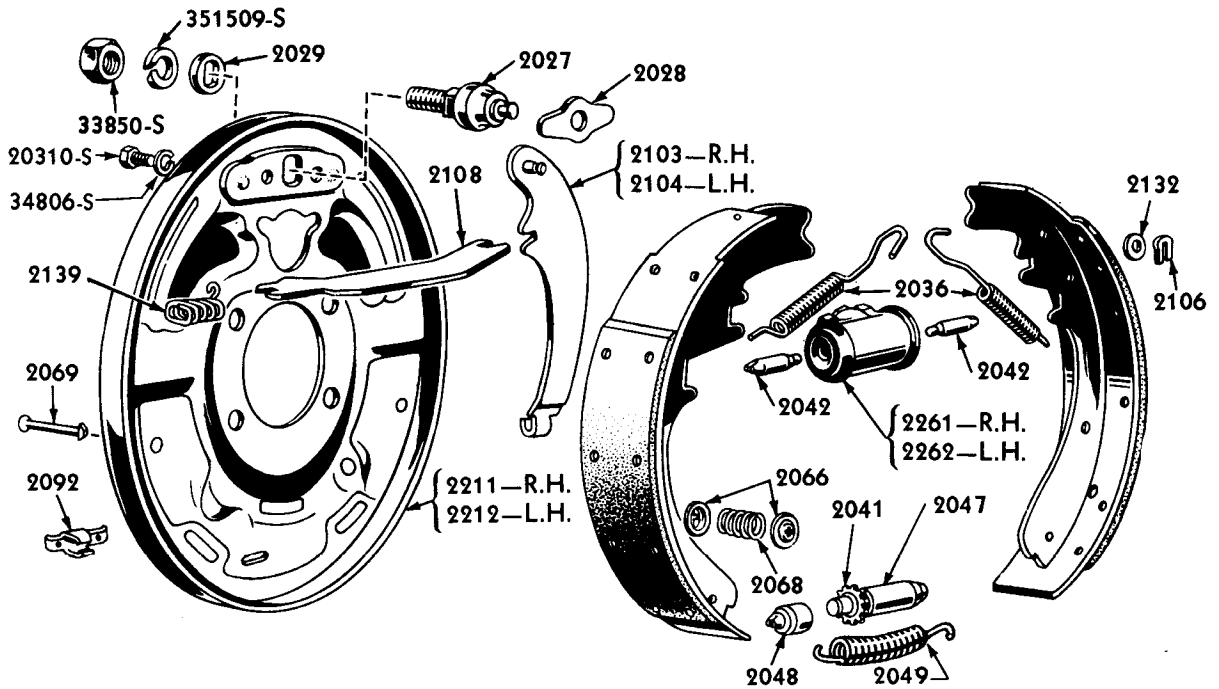

### REAR BRAKES

PL-781

Basic numbers only shown on illustration. Order by Part Numbers shown in list of parts.

PART NUMBER	UNIT	PART NAME	NO. REQ'D	MODEL	YEAR
OL-2001		Kit (brake shoe & lining)-complete car-marked with (2) White paint stripes-consists of the following (2) 8L-2018-D Shoe & lining-front-primary (2) 8L-2218-D Shoe & lining-rear-primary (2) OL-2019-B Shoe & lining-front-secondary (2) OL-2219-B Shoe & lining-rear-secondary	1	9L,9H,OL,OH,1L,1H	19 49-51
8L 2201	NS	Cup (rear wheel brake cylinder)-15/16" diameter-order 8L-2128 Kit	4	9L,9H,OL,OH,1L,1H	49-51
91A 2202		Cup (front wheel brake cylinder)-1-1/8" diameter	4	9L,9H,OL,OH,1L,1H	49-51
96H 2204		Spring (rear wheel brake cylinder piston return)-9/16" O.D. x 2-5/16" o/all free length x 11 coils	2	9L,9H,OL,OH,1L,1H	49-51
96H 2205		Spring (front wheel brake cylinder piston return)-11/16" O.D. x 2-1/4" o/all free length x 9-1/2 coils	2	9L,9H,OL,OH,1L,1H	49-51
96H 2206		Boot (brake wheel cylinder)-rear-1-1/2" O.D.	4	9L,9H,OL,OH,1L,1H	49-51
OM 2207-A		Boot (brake wheel cylinder)-front-1-5/8" O.D.	4	9L,9H,OL,OH,1L,1H	49-51
8M 2208		Screw (brake wheel cylinder bleeder)-3/8"-24 x 1-3/16" overall length	4	9L,9H,OL,OH,1L,1H	49-51
8L 2209		Brake assy (rear)-RH	1	9L,9H,OL,OH	49-50
OL 2209		Brake assy (rear)-RH-marked with (2) White paint stripes-use only in sets-OL-2209 and OL-2210	1	9L,9H,OL,OH,1L,1H	49-51
8L 2210		Brake assy (rear)-LH	1	9L,9H,OL,OH	49-50
OL 2210		Brake assy (rear)-LH-marked with (2) White paint stripes-use only in sets-OL-2209 and OL-2210	1	9L,9H,OL,OH,1L,1H	49-51

# Lincoln and Lincoln Cosmopolitan

## CHASSIS PARTS CATALOGUE

PART NUMBER	PART NAME	NO. REQ'D	MODEL	YEAR
<b>Service Brakes—Continued</b>				
8L 2211-A	Plate assy (rear brake backing)-RH-unpainted-optional with 8L-2211-B	1	9L,9H,OL,OH,1L,1H	49-51
8L 2211-B	Plate assy (rear brake backing)-RH-painted-optional with 8L-2211-A	1	9L,9H,OL,OH,1L,1H	49-51
8L 2212-A	Plate assy (rear brake backing)-LH-unpainted-optional with 8L-2212-B	1	9L,9H,OL,OH,1L,1H	49-51
8L 2212-B	Plate assy (rear brake backing)-LH-painted-optional with 8L-2212-A	1	9L,9H,OL,OH,1L,1H	49-51
	8M-2248 Bolt (rear axle brake housing)-1/2"-20 x 1-1/8" special head	8	9L,9H,OL,OH,1L,1H	49-51
8M 2221	Kit (front wheel brake cylinder repair)-consists of the following (2) 91A-2202 Cup (2) 0M-2207-A Boot	2	9L,9H,OL,OH,1L,1H	49-51
• 8L 2222-A	Kit (rear brake lining)-.202"/.222" thickness-consists of the following (2) 8L-2284-A Lining (2) 8L-2285-A Lining (45) 351939-S Rivet	1	9L,9H	49
•• 8L 2222-B	Kit (rear brake lining)-.182"/.192" thick-consists of the following (2) 8L-2284-B Lining (2) 8L-2285-B Lining (45) 351939-S Rivet	1	9L,9H	49
♦ 8L 2222-C	Kit (rear brake lining)-.182"/.192" thick-with short primary lining-consists of the following (2) 8L-2284-D Lining (2) 8L-2285-B Lining (45) 351939-S Rivet	1	9L,9H,OL,OH	49-50
8M 2222-A	Kit (rear brake lining)-.182"/.192" thick-Standard-Axle Set-consists of the following (2) 8L-2284-D Lining-rear primary (2) 0L-2285-B Lining-rear secondary (40) 351939-S Rivet (flat-head-9/64" x 1/4")	1	9L,9H,OL,OH,1L,1H	49-51
	0L-2007 Kit (brake lining and rivet)-complete car-marked with (2) White paint stripes	1	9L,9H,OL,OH,1L,1H	49-51
8M 2240	Retainer (rear wheel bearing)	2	9L,9H,OL,OH,1L,1H	49-51
8M 2244	Clip (brake pipe to rear axle)	1 or 2	9L,9H,OL,OH,1L,1H	49-51
8M 2244	Clip (front brake pipe)	2	9L,9H,OL,OH,1L,1H	49-51
	31527-S7 Screw (hex washer head self tap.)-No. 14-14 x 1/2"	as reqd	9L,9H,OL,OH,1L,1H	49-51
8M 2245	Gasket (wheel bearing retainer)-Paper	4	9L,9H,OL,OH,1L,1H	49-51
8M 2248	Bolt (rear axle brake housing)-1/2"-20 x 1-1/8"-special head	8	9L,9H,OL,OH,1L,1H	49-51
	34424-S7 Locknut (hex)-1/2"-20	8	9L,9H,OL,OH,1L,1H	49-51
8L 2261-A	Cylinder assy (rear brake)-RH-15/16" diameter	1	9L,9H,OL,OH,1L,1H	49-51
8L 2262-A	Cylinder assy (rear brake)-LH-15/16" diameter	1	9L,9H,OL,OH,1L,1H	49-51
	20310-S2 Bolt (hex head)-5/16"-18 x 1/2"	4	9L,9H,OL,OH,1L,1H	49-51
	34806-S7 Lockwasher-5/16"	4	9L,9H,OL,OH,1L,1H	49-51

- Used with 8L-2007-A Kit
- Used with 8L-2007-B Kit
- ♦ Used with 8L-2007-C Kit

# Lincoln and Lincoln Cosmopolitan

## CHASSIS PARTS CATALOGUE

### Service Brakes—Continued

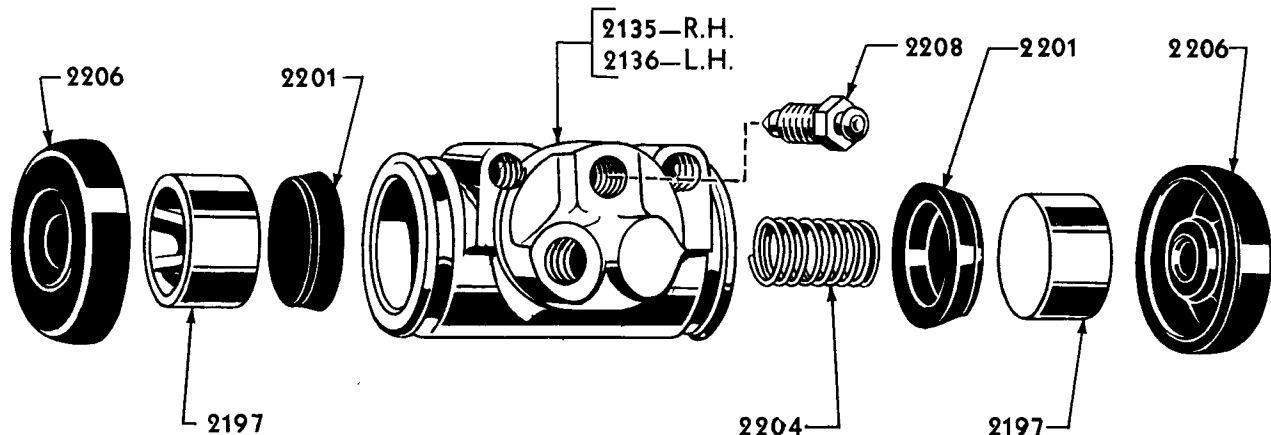

PL-163

### REAR WHEEL BRAKE CYLINDER

Basic numbers only shown on illustration. Order by Part Numbers shown in list of parts.

PART NUMBER	QUANTITY	PART NAME	NO. REQ'D	MODEL	YEAR		
8L-2128		Kit (rear wheel brake cyl. repair)- consists of the following	2	9L,9H,OL,OH,1L,1H	49-51		
(2) 8L-2201		Cup	(2)	96H-2206	Boot		
8L 2263-A		Pipe assy (front brake)	1	9L,9H	49		
8L 2263-B		Pipe assy (front brake)	1	9L,OL,1L	49-51		
8M-2244		Clip (front brake pipe to front cross member)	2	9L,9H,OL,OH,1L,1H	49-51		
OH 2263		Pipe assy (front brake)	1	9H,OH,1H	49-51		
8L 2264		Pipe assy (master cylinder to front brake)-14-5/16" long	1	9L,9H,OL,OH,1L,1H	49-51		
8H 2265		Pipe assy (master cylinder to rear hose)-116-5/8" long	1	9H,OH,1H	49-51		
8M 2265		Pipe assy (master cylinder to rear hose)-106-1/8" long	1	9L,OL,1L	49-51		
		7RA-14197-B		Clip (for attaching master cylinder pipe to frame)	3or4	9L,9H,OL,OH,1L,1H	49-51
8H 2267		Pipe assy (rear brake)-right-45-3/4" long	1	9H,OH,1H	49-51		
8M 2267		Pipe assy (rear brake)-right-50" long	1	9L,OL,1L	49-51		
		8M-2244		Clip (rear brake right pipe)	1or2	9L,9H,OL,OH,1L,1H	49-51
		20328-S		Bolt (hex head)-3/8"-16 x 5/8"- for attaching rear brake right pipe clip	1	9L,9H,OL,OH,1L,1H	49-51
		358349-832		Clip (rear brake right pipe)- fastened to rear axle diff. housing	1	9L,9H,OL,OH,1L,1H	49-51
		34807-S2		Lockwasher-3/8"-use with 20328-S	1	9L,9H,OL,OH,1L,1H	49-51
8H 2268		Pipe assy (rear brake)-left-13-7/8" long	1	9H,OH,1H	49-51		
8L 2268		Pipe assy (rear brake)-left-10-1/16" long	1	9L,OL,1L	49-51		

# Lincoln and Lincoln Cosmopolitan

## CHASSIS PARTS CATALOGUE

PART NUMBER	PART NAME	NO. REQ'D	MODEL	YEAR
<b>Service Brakes—Continued</b>				
8H 2275	Cable & conduit assy (hand brake)-rear-136-1/4" long	1	9H,OH	49-50
OH 2275	Cable & conduit assy (hand brake)-rear-135-7/8" long	1	OH,1H	50-51
8M 2275	Cable & conduit assy (hand brake)-rear-137-3/4" long	1	9L,OL	49-50
OM 2275	Cable & conduit assy (hand brake)-rear-134-1/2" long	1	OL,1L	50-51
	353364-S Clip (cable)-cable to frame side member	2	9H,OH,1H	49-51
	31527-S7 Screw (hex washer head self tapping)-No. 14-14 x 1/2"	2	9H,OH,1H	49-51
	8M-2814 Clip (hand brake cable spring lock) -U shaped-cable to frame bracket and to rear axle	as reqd	9L,9H,OL,OH,1L,1H	49-51
8L 2276	Bolt (rear brake cylinder connection)-for attaching brake master cylinder outlet fitting	1	9L,9H,OL,OH,1L,1H	49-51
OM 2279	Clip (hand brake cable)-cable to frame	1	OL,OH,1L,1H	50-51
1M 2279-A	Clip (hand brake cable)-cable to frame	1	1L,1H	51
	350209-S2 Bolt (hex-hd)-5/16"-10 x 1/2" -clip to "K" bar	1	1L,1H	51
	31527-S7 Screw (hex washer head self tapping)-No. 14-14 x 1/2"-clip to "K" bar	1	OL,OH,1L,1H	50-51

## Service Brake Controls

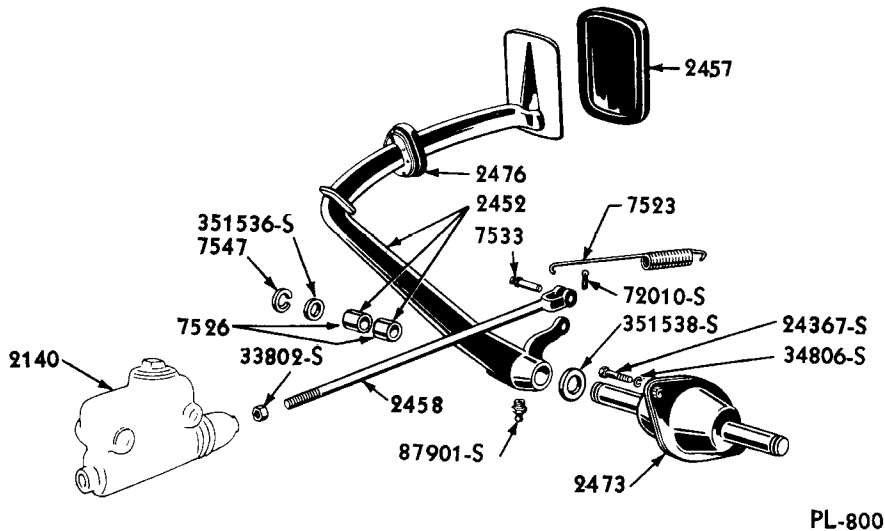

### BRAKE PEDAL

Basic numbers only shown on illustration. Order by Part Numbers shown in list of parts.

8M 2452-A2	Pedal & bushing assy (brake)-forging type-use with 8M-7520-C2	1	9L,9H,OL,OH,1L,1H	49-51
8M 2452-A3	Pedal & bushing assy (brake)-pressed steel type-use with 8M-7520-C1	1	9L,9H,OL,OH	49-50

# Lincoln and Lincoln Cosmopolitan

## CHASSIS PARTS CATALOGUE

PART NUMBER	C L A S S I F I C A T I O N	PART NAME	NO. REQ'D	MODEL	YEAR 19__
<b>Service Brake Controls—Continued</b>					
HAK 2452-A		Kit (brake or clutch pedal extension)-consists of the following (1) 1H-22456-A Plate (2) 1H-22457-A Base (2) 1H-22460-A Retainer (1) 350479-S2 Bolt (1) 356060-S32 Nut (2) 72857-S Pin	1	9L,9H,0H,0L,1L,1H	49-51
HAK 2452-B		Kit (brake or clutch pedal extension additive)-consists of the following (1) 1H-22456-A Plate (2) 72857-S Pin	1	9L,9H,0L,0H,1L,1H	49-51
		01A-7526-A Bushing (brake & clutch pedal)-3/4" I.D. x 13/16" O.D. x 11/16" long	4	9L,9H,0L,0H,1L,1H	49-51
		87901-S8 Fitting (lubricator)-1/8" straight	2	9L,9H,0L,0H,1L,1H	49-51
		01A-7547 Retainer (clutch and brake pedal)-11/16" I.D. x 3/32" thick-open ends	2	9L,9H,0L,0H,1L,1H	49-51
8A 2456-B		Spring (hand brake equalizer lever retracting)-8" free length-34 coils	1	0L,0H,1L,1H	50-51
8H 2456		Spring (brake pedal retracting)-23/32" O.D. x 6-7/8" free length-19 coils	1	9H,0H,1H	49-51
		91A-7523 Spring (brake pedal retracting)-23/32" O.D. x 5-19/32" free length-19 coils	1	9L,0L,1L	49-51
NS		1H-22456-A Plate (brake pedal extension)-serviced in HAK-2452-A & B Kit	1	9L,9H,0L,0H,1L,1H	49-51
8M 2457		Pad (clutch and brake pedal)-Rubber	1 or 2	9L,9H,0L,0H,1L,1H	49-51
		B-7533-B Pin (clevis)-grooved-5/16" diameter x 1-7/16" overall length	1	9L,9H,0L,0H,1L,1H	49-51
NS		1H-22457-A Base (brake pedal extension)-serviced in HAK-2452-A Kit	2	9L,9H,0L,0H,1L,1H	49-51
		33802-S8 Nut (hex)-7/16"-20	1	9L,9H,0L,0H,1L,1H	49-51
8M 2458		Rod assy (brake pedal to master cylinder)	1	9L,9H,0L,0H,1L,1H	49-51
NS		1H-22460-A Retainer (brake pedal extension base)-serviced in HAK-2452-A Kit	2	9L,9H,0L,0H,1L,1H	49-51
		72010-S Cotter pin-1/8" x 5/8"	1	9L,9H,0L,0H,1L,1H	49-51
8M 2473		Shaft and bracket assy (clutch and brake pedal)	1	9L,9H,0L,0H,1L,1H	49-51
		24367-S7 Bolt (hex head)-5/16"-24 x 7/8"	2	9L,9H,0L,0H,1L,1H	49-51
		34806-S7 Lockwasher-5/16"	2	9L,9H,0L,0H,1L,1H	49-51
		351536-S7 Washer (plain)-3/4" I.D. x 1-1/8" O.D. x 3/32" thick	2	9L,9H,0L,0H,1L,1H	49-51
		351538-S7 Washer (flat)-3/4" I.D. x 1-3/8" O.D. x 3/32" thick	2	9L,9H,0L,0H,1L,1H	49-51
8M 2476		Weatherseal assy (brake pedal)-Rubber	1	9L,9H,0L,0H,1L,1H	49-51
8M 2476		Weatherseal assy (clutch pedal)-Rubber	1	9L,9H,0L,0H,1L,1H	49-51
OM 2529		Rod (hand brake equalizer)-5-23/32" overall length-with one end bent at right angle to threaded dia.	1	0L,0H,1L,1H	50-51
		33798-S8 Nut (hex)-5/16"-24	2	0L,0H,1L,1H	50-51
		351640-S32 Nut (round-spring)-9/32"-to hold hand brake spring	1	0L,0H,1L,1H	50-51



# Lincoln and Lincoln Cosmopolitan

## CHASSIS PARTS CATALOGUE

PART NUMBER	PART NAME	NO. REQ'D	MODEL	YEAR 19
<b>Service Brake Controls—Continued</b>				
8M 2530-A	Bracket (hand brake cable)-rear-RH-welded onto rear "K" frame members-flanged edge formed inward-used with 8L-5005-A	1	9L except 76	49
OM 2530	Bracket (hand brake cable)-rear-RH-with 2-13/32" diameter bolt holes for attaching to frame	1	OL,1L	50-51
8M 2531-A	Bracket (hand brake cable)-rear-LH-welded onto rear "K" frame members-flanged edge formed inward-used with 8L-5005-A	1	9L except 76	49
OM 2531	Bracket (hand brake cable)-rear-LH-with 2-13/32" diameter bolt holes for attaching to frame	1	OL,1L	50-51
	OM-55052 Retainer assy (speed grip nut)- includes 3/8"-24 square nut	4	OL,1L	50-51
	24349-S7 Bolt (hex head)-3/8"-24 x 3/4"- attaches OM-2530-31 to frame side member	4	OL,1L	50-51
	34807-S2 Lockwasher-3/8"-used with OM-2530-31	4	OL,1L	50-51
	356006-S2 Nut (retainer)-3/8"-24-bracket to frame	4	9L,OL,1L	49-51
OM 2532	Lever (hand brake equalizer)	1	OL,OH,1L,1H	50-51
	8A-2091 Nut (hand brake equalizer lever)- 5/16"-24-equalizer lever to front cable assy	1	OL,OH,1L,1H	50-51
	8A-2456-B Spring (hand brake equalizer lever retracting)-8" free length-34 coils	1	OL,OH,1L,1H	50-51

## Emergency Brake and Hand Brake Lever

8H 2780-A2	Control assy (hand brake)-with fulcrum lever at end	1	9H	49
8L 2780-A2	Control assy (hand brake)-with fulcrum lever at end	1	9L	49
OM 2780	Control assy (hand brake)-with pulley at end	1	OL,OH,1L,1H	50-51
	24327-S7 Bolt (hex head)-5/16"-24 x 5/8"-hand brake control to dash panel	2	9L,9H,OL,OH,1L,1H	49-51
	24347-S8 Bolt (hex head)-5/16"-24 x 3/4"-hand brake assy to instr. panel	2	9L,9H,OL,OH,1L,1H	49-51
	355410-S2 Bolt (carriage)-5/16"-24 x 5/8"-hand brake control to instrument panel	2	9L,9H	49
	350791-S Bolt (special hex shoulder)- 3/8"-24 x 3/4"-hand brake to body bracket	1	9L	49
	350583-S2 Bolt (hex head shoulder)-3/8"- 24 x 27/32"-hand brake control lever to body brkt.	1	9H	49
	350479-S2 Bolt (hex head Acme thread)- 5/16"-10 x 5/8"-hand brake bracket to cowl side	1	9L	49
	350479-S2 Bolt (hex head Acme thread)- 5/16"-10 x 5/8"-hand brake bracket to front body pillar	2	9L	49
	34443-S8 Locknut (hex)-5/16"-24-hand brake control bolt to instrument panel	2	9L,9H	49

# Lincoln and Lincoln Cosmopolitan

## CHASSIS PARTS CATALOGUE

PART NUMBER	C C A S E	PART NAME	NO. REQ'D	MODEL	YEAR 19__
<b>Emergency Brake and Hand Brake Lever—Continued</b>					
		34445-S7 Locknut (hex)-3/8"-24-to body reinforcement bracket	1	9L	49
		73880-S8 Pin (clevis)-5/16" x 13/16"-pulley to OM-2780	1	OL,OH	50
		357614-S8 Pin (grooved)-5/32" x 25/32"-fastens handle to shaft	1	9L,9H	49
		352358-S Pin (self locking)-9/32" x 61/64"-used with 73880-S8	1	OL,OH	50
		42719-S Screw & lockwasher assy (hex head)-5/16"-18 x 5/8"-hand brake lever bracket to front body pillar	3	9H	49
		42789-S7 Screw & lockwasher assy (hex head)-5/16"-18 x 3/4"-emer. brake to reinforcement assy	2	9H	49
		34826-S7 Washer (spring lock)-5/16"-control assy to dash panel	2	OL,OH,LL,LH	50-51
		34826-S7 Washer (spring lock)-5/16"-control assy to instr. panel	2	OL,OH,LL,LH	50-51
		351473-S7 Washer (spring)-1/2"-use with 350583-S2	1	9H	49
OM 2786		Retainer (ratchet bar locking spring)	1	OL,OH,LL,LH	50-51
OM 2788		Spring (ratchet bar locking)-outer	1	OL,OH,LL,LH	50-51
8M 2795-B		Bracket (hand brake lever)	1	9L	49
		350479-S8 Bolt (hex-hd Acme thread)-5/16"-10 x 5/8"-to cowl side panel and body front pillar	3	9L	49
		350945-S32 Nut (spring)-5/16"-10-hand brake brkt. to cowl side and pillar	3	9L	49
		8H-7301701 Brkt. assy (hand brake lever)-to cowl side panel & body frt. pillar	1	9H	49
OM 2804		Pulley assy (hand brake cable)	1	OL,OH,LL,LH	50-51
		73880-S8 Pin (clevis)-5/16" x 13/16"	1	OL,OH,LL,LH	50-51
		352358-S Pin (self locking)-9/32" x 61/64"-used with 73880-S8	1	OL,OH,LL,LH	50-51
8M 2814		Clip (hand brake cable spring lock)-U shaped-with pointed ends	as reqd	9L,9H,OL,OH,LL,LH	49-51
78 2814-A		Clip (brake pipe hose to frame bracket)-U shaped-with straight ends	3	9L,9H,OL,OH,LL,LH	49-51
OM 2819		Pin (hand brake handle locking)-straight knurled-5/32" diameter x 13/32" overall length	1	OL,OH,LL,LH	50-51
OH 2853		Cable and conduit assy (hand brake)-front	1	OH,LH	50-51
**8M 2853-A		Cable and conduit assy (hand brake)-front-with 3-9/16" thread length at equalizer end	1	9L,9H	49
*8M 2853-B		Cable and conduit assy (hand brake)-front-with 5-5/16" thread length at equalizer end	1	9L,9H	49
OM 2853		Cable and conduit assy (hand brake)-front	1	OL,LL	50-51

\*\* Not used with HYDRA-MATIC transmission

\* Used with HYDRA-MATIC transmission

# Lincoln and Lincoln Cosmopolitan

## CHASSIS PARTS CATALOGUE

PART NUMBER	PART NAME	NO. REQ'D	MODEL	YEAR
<b>Emergency Brake and Hand Brake Lever—Continued</b>				
8A 2859	Pin (hand brake lever)-straight knurled-5/32" diameter x 15/16" overall length	1	9L,9H	49
OM 2859	Pin (hand brake lever)-straight knurled-.162" diameter x .275" diameter x 15/16" overall length	1	OL,OH,1L,1H	50-51
	OM-7201695 Grommet (hand brake cable opening in dash)-Corrugated Rubber	1	OL,OH,1L,1H	50-51
	73861-S Clevis pin-5/16" x 5/8"-cable to hand brake lever control	1	9L,9H	49
	72010-S Cotter pin-1/8" x 5/8"-cable to hand brake lever control	1	9L,9H	49
	352358-S Pin (self locking)-9/32" x 61/64"-cable to hand brake control	1	9H	49
	8M-2153-A Bracket (hand brake cable)-with 13/32" diameter hole	1or3	9L,9H	49
	8H-2153 Bracket (hand brake cable)-45° angle-weld on type	1	OH,1H	50-51
	8L-2153 Bracket (hand brake cable)-bolt on type	1	9L,OL	49-50
	OM-2279 Clip (hand brake cable)-cable to frame "K" bar	1	OL,OH,1L,1H	50-51
	1M-2279-A Clip (hand brake cable)-cable to frame	1	1L,1H	51
	350209-S2 Bolt (hex-hd)-5/16"-10 x 1/2"-to "K" bar	1	1L,1H	51
	31527-S7 Screw (hex washer head self tapping)-No. 14-14 x 1/2"-clip to frame "K" bar	1	OL,OH,1L,1H	50-51
	8M-2814 Clip (hand brake cable spring lock) -U shaped-control cable to body bracket	1	9L,9H,OL,OH,1L,1H	49-51
	8M-2814 Clip (hand brake cable spring lock) -control cable to frame cross member	1	9L,9H,OL,OH,1L,1H	49-51
	11A-14598 Clip (cable)-hand brake front cable to frame & front fender apron also engine rear support	as reqd	9L,9H	49
	91A-14602-A Grommet (insulator)-Rubber-for hand brake cable	as reqd	9L,OL	49-50
	86H-17264-A Clip (cable)-for attaching hand brake frt. cable to frame	1	9H,OH,1H	49-51
	33796-S2 Nut (hex)-1/4"-28-for attaching cable clip to front fender apron	1	9L,9H	49
	33798-S2 Nut (hex)-5/16"-24-front cable to equalizer	2	9L,9H,OL,OH,1L,1H	49-51
	33444-S2 Screw (pan head self tapping)-No. 10-16 x 1/2"-cable to dash	2	9L,OL,1L	49-51
	41178-S8 Screw (hex-hd self tapping)-No. 10-24 x 3/8"-cable to front apron & frame also engine rear support	2or3	9L,9H	49
	42007-S7 Screw (hex-hd self tapping)-No. 10-12 x 3/8"-cable to front fender apron	2	9L,9H	49

# Lincoln and Lincoln Cosmopolitan

## CHASSIS PARTS CATALOGUE

PART NUMBER	CLASS	PART NAME	NO. REQ'D	MODEL	YEAR 19 _____
-------------	-------	-----------	-----------	-------	------------------

### Emergency Brake and Hand Brake Lever—Continued

		31527-S7 Screw (hex washer hd self tap.) -No. 14-14 x 1/2"-for attaching 86H-17264-A to frame	1	9H,OH,1H	49-51
		8M-2275 Cable and conduit assy (hand brake) -rear-137-3/4" overall length	1	9L,OL	49-50
		OM-2275 Cable and conduit assy (hand brake) -rear-134-1/2" long	1	OL,1L	50-51
		8H-2275 Cable and conduit assy (hand brake) -rear-136-1/4" overall length	1	9H,OH	49-50
		OH-2275 Cable and conduit assy (hand brake) -rear-135-7/8" long	1	OH,1H	50-51

## Front Suspension

8M 3020-A	Bumper assy (front suspension lower arm)-2-1/4" overall length of Rubber-use in pairs	2	9L,9H	49
8M 3020-B	Bumper assy (front suspension lower arm)-2-3/4" overall length of Rubber-use in pairs	2	9L,9H,OL,OH,1L,1H	49-51
	34807-S2 Lockwasher-3/8"	2	9L,9H,OL,OH,1L,1H	49-51
	33800-S2 Nut (hex)-3/8"-24	2	9L,9H,OL,OH,1L,1H	49-51
8M 3025	Bumper (front suspension rebound)-upper-1-9/16" overall length-used in pairs	2	9L,9H	49
8L 3025	Bumper (front suspension rebound)-upper-2-1/2" overall length-used in pairs	2	9L,9H,OL,OH,1L,1H	49-51
8M 3042	Arm & inner shaft assy (front suspension)-lower	2	9L,9H,OL,OH,1L,1H	49-51
	24523-S8 Bolt (hex head)-3/8"-24 x 2"- lower arm to spindle support	2	9L,9H,OL,OH,1L,1H	49-51
	350811-S7 Bolt (hex head)-7/16"-20 x 1-3/8"-lower arm to frame cross member	8	9L,9H,OL,OH,1L,1H	49-51
	353031-AS7 Fitting (lubricator)-1/8" x 67-1/2°-rear	2	9L,9H,OL,OH,1L,1H	49-51
	353047-AS7 Fitting (lub.)-1/8"-27 x 1/2" straight-front	2	9L,9H,OL,OH,1L,1H	49-51
	34447-S2 Locknut (hex)-7/16"-20 lower arm to frame cross member	8	9L,9H,OL,OH,1L,1H	49-51
	34807-S2 Lockwasher-3/8"	2	9L,9H,OL,OH,1L,1H	49-51
8M 3044	Arm & inner shaft assy (front suspension)-upper	2	9L,9H,OL,OH,1L,1H	49-51
	24523-S8 Bolt (hex head)-3/8"-24 x 2"- upper arm to spindle support	2	9L,9H,OL,OH,1L,1H	49-51
	350790-S7 Bolt (hex head)-9/16"-18 x 1-27/32"-upper arm to frame cross member	4	9L,9H,OL,OH,1L,1H	49-51
	353031-AS7 Fitting (lubricator)-1/8" x 67-1/2°	4	9L,9H,OL,OH,1L,1H	49-51
	34451-S Locknut (hex)-9/16"-18-upper suspension arm to frame bolt	4	9L,9H,OL,OH,1L,1H	49-51
	34807-S2 Lockwasher-3/8"	4	9L,9H,OL,OH,1L,1H	49-51
8M 3046	NS Bushing (spindle support)-upper-replaced by 8M-3049 Kit	2	9L,9H,OL,OH,1L,1H	49-51

# Lincoln and Lincoln Cosmopolitan

## CHASSIS PARTS CATALOGUE

### Front Suspension—Continued

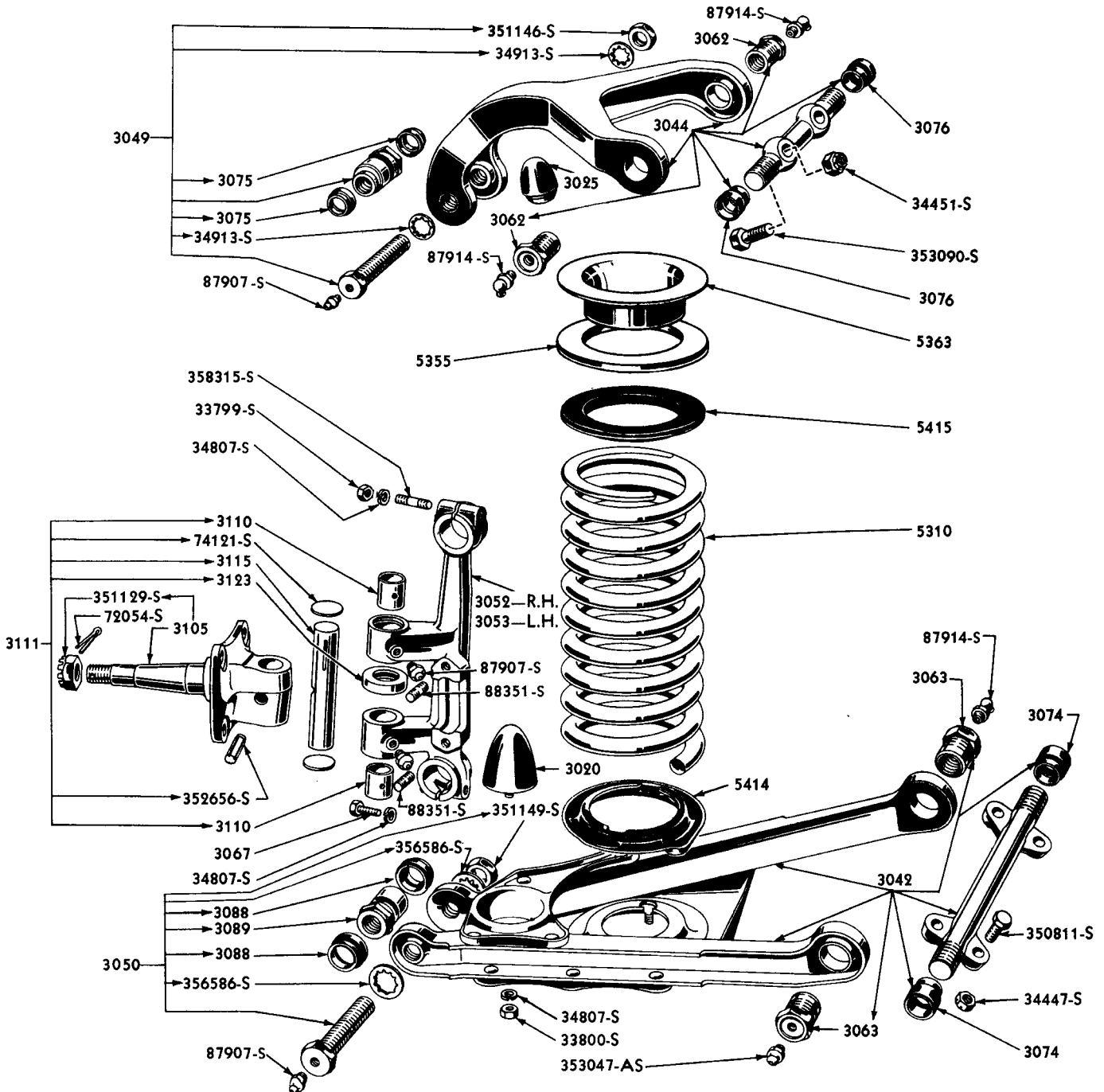

PL-732

### FRONT SUSPENSION

Basic numbers only shown on illustration. Order by Part Numbers shown in list of parts.

# Lincoln and Lincoln Cosmopolitan

## CHASSIS PARTS CATALOGUE

PART NUMBER	PART NAME	NO. REQ'D	MODEL	YEAR 19__
<b>Front Suspension—Continued</b>				
8M 3047	Kit (front suspension upper inner shaft)-consists of the following (1) 8M-3056 Shaft (2) 8M-3062 Bushing (2) 8M-3076 Seal	1	9L,9H,OL,OH,1L,1H	49-51
8M 3048	Kit (front suspension lower inner shaft)-consists of the following (1) 8M-3057 Shaft (2) 8M-3063 Bushing (2) 8M-3074 Seal	1	9L,9H,OL,OH,1L,1H	49-51
8M 3049	Kit (front suspension upper arm to spindle support bolt)-consists of the following (1) 8M-3046 Bushing (1) 8M-3072 Bolt (1) 8M-3075 Seal (2) 34913-S Lockwasher (1) 351146-S7 Nut	1	9L,9H,OL,OH,1L,1H	49-51
8M 3050	Kit (front suspension lower arm to spindle support bolt)-consists of the following (1) 8M-3073 Bolt (2) 8M-3088 Seal (1) 8M-3089 Bushing (1) 351149-S7 Nut (1) 356586-S2 Lockwasher	1	9L,9H,OL,OH,1L,1H	49-51
8M 3052	Support assy (spindle)-RH	1	9L,9H,OL,OH,1L,1H	49-51
8M 3053	Support assy (spindle)-LH	1	9L,9H,OL,OH,1L,1H	49-51
	8M-3067 Bolt (spindle support clamping)-hex head-3/8"-24 x 1-29/32"	2	9L,9H,OL,OH,1L,1H	49-51
NS	8M-3110 Bushing (front wheel spindle pin)-replaced by 8M-3111 Kit	4	9L,9H,OL,OH,1L,1H	49-51
	353043-AS7 Fitting (lubricator)-short-1/4"-28 x 1/2"	4	9L,9H,OL,OH,1L,1H	49-51
	34807-S2 Lockwasher-3/8"-spindle support	4	9L,9H,OL,OH,1L,1H	49-51
	33799-S7 Nut (hex)-3/8"-16-spindle support-upper	2	9L,9H,OL,OH,1L,1H	49-51
	74121-S Plug (expansion)-1-1/4"-spindle support	4	9L,9H,OL,OH,1L,1H	49-51
	88351-S8 Stud-5/16"-18 & 5/16"-24 x 7/8"-stabilator to support	4	9L,9H,OL,OH,1L,1H	49-51
	352755-S8 Stud-3/8"-16 and 3/8"-24 x 2-1/16"-spindle support-upper	2	9L,9H,OL,OH,1L,1H	49-51
8M 3056	NS Shaft (front suspension upper arm)-inner-replaced by 8M-3047 Kit	2	9L,9H,OL,OH,1L,1H	49-51
	353031-AS7 Fitting (lubricator)-1/8"-27 x 67-1/2°	4	9L,9H,OL,OH,1L,1H	49-51
8M 3057	NS Shaft (front suspension lower arm)-inner-replaced by 8M-3048 Kit	2	9L,9H,OL,OH,1L,1H	49-51
	353047-AS7 Fitting (lubricator)-1/8"-27 x 1/2"-forward end	2	9L,9H,OL,OH,1L,1H	49-51
	353031-AS7 Fitting (lubricator)-1/8"-27 x 67-1/2°-rear end	2	9L,9H,OL,OH,1L,1H	49-51
8M 3062	Bushing assy (front suspension upper arm inner shaft)	4	9L,9H,OL,OH,1L,1H	49-51
8M 3063	Bushing assy (front suspension lower arm inner shaft)	4	9L,9H,OL,OH,1L,1H	49-51

# Lincoln and Lincoln Cosmopolitan

## CHASSIS PARTS CATALOGUE

PART NUMBER	QTY	PART NAME	NO. REQ'D	MODEL	YEAR 19__
<b>Front Suspension—Continued</b>					
8M 3067		Bolt (spindle support clamping)-lower-hex head- 3/8"-24 x 1-29/32"	2	9L,9H,OL,OH,1L,1H	49-51
8M 3072	NS	Bolt (front suspension upper arm to spindle support) -replaced by 8M-3049 Kit	2	9L,9H,OL,OH,1L,1H	49-51
		353043-AS7 Fitting (lubricator)-short-1/4" -28 x 1/2"-straight	2	9L,9H,OL,OH,1L,1H	49-51
		34913-S Lockwasher (internal tooth)-3/4"	4	9L,9H,OL,OH,1L,1H	49-51
		351146-S7 Nut (hex)-3/4"-11	2	9L,9H,OL,OH,1L,1H	49-51
8M 3073	NS	Bolt (front suspension lower arm to spindle support) -replaced by 8M-3050 Kit	2	9L,9H,OL,OH,1L,1H	49-51
		353043-AS7 Fitting (lubricator)-short-1/4" -28 x 1/2"-straight	2	9L,9H,OL,OH,1L,1H	49-51
		356586-S2 Lockwasher (internal tooth)-7/8"	4	9L,9H,OL,OH,1L,1H	49-51
		351149-S7 Nut (hex)-7/8"-11	2	9L,9H,OL,OH,1L,1H	49-51
8M 3074		Seal (front suspension lower arm shaft)-inner	4	9L,9H,OL,OH,1L,1H	49-51
8M 3075		Seal (front suspension upper arm)-outer	4	9L,9H,OL,OH,1L,1H	49-51
8M 3076		Seal (front suspension upper arm shaft)-inner	4	9L,9H,OL,OH,1L,1H	49-51
8M 3088		Seal (front suspension lower arm)-outer	4	9L,9H,OL,OH,1L,1H	49-51
8M 3089	NS	Bushing (spindle pin support)-lower-repl. by 8M-3050 Kit	2	9L,9H,OL,OH,1L,1H	49-51
8M 3105		Spindle assy (front wheel)-includes nut	2	9L,9H,OL,OH,1L,1H	49-51
		72054-S Cotter pin-5/32" x 1-1/4"	2	9L,9H,OL,OH,1L,1H	49-51
		351129-S Nut (hex slotted)-3/4"-16	2	9L,9H,OL,OH,1L,1H	49-51
8M 3110	NS	Bushing (front wheel spindle pin)-replaced by 8M-3111 Kit	4	9L,9H,OL,OH,1L,1H	49-51
8M 3111		Kit (spindle bolt & bushing)-consists of the follow- ing (4) 8M-3110 Bushing (2) 8M-3115 Pin (2) HB-3123-A Bearing (4) 74121-S Plug (2) 352656-S8 Pin	1	9L,9H,OL,OH,1L,1H	49-51
8M 3115	NS	Pin (front wheel spindle)-replaced by 8M-3111 Kit	2	9L,9H,OL,OH,1L,1H	49-51
		352656-S8 Pin (grooved)-7/16" diameter x 1-3/4" long	2	9L,9H,OL,OH,1L,1H	49-51
HB 3123-A		Bearing assy (spindle bolt)-roller type-.938"/.944" I.D. x 1.770"/1.780" O.D. x .534" thick	2	9L,9H,OL,OH,1L,1H	49-51
8M 3130		Arm (spindle steering)-RH	1	9L,9H,OL,OH,1L,1H	49-51
8M 3131		Arm (spindle steering)-LH	1	9L,9H,OL,OH,1L,1H	49-51



# Lincoln and Lincoln Cosmopolitan

## CHASSIS PARTS CATALOGUE

### Steering Linkage

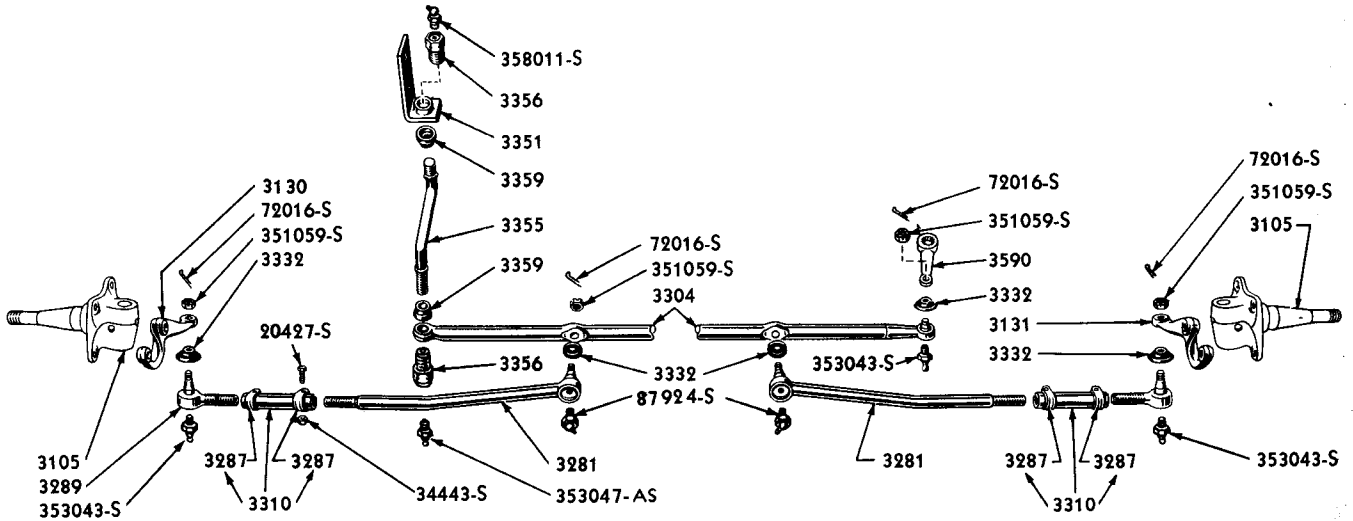

PM-555

### STEERING LINKAGE

Basic numbers only shown on illustration. Order by Part Numbers shown in list of parts.

PART NUMBER	QUANTITY	PART NAME	NO. REQ'D	MODEL	YEAR 19__
GM 3270		Kit (steering spindle connecting rod end)-consists of the following (1) GM-3289 End Assy (1) GM-3332 Seal (1) 72016-S Cotter pin(1) 351059-S7 Nut (1) 353043-AS7 Fitting	1	9L,9H,OL,OH,1L,1H	49-51
GM 3281		Rod & ball stud Assy (tie)	2	9L,9H,OL,OH,1L,1H	49-51
		72016-S8 Cotter pin-3/32" x 3/4"	2	9L,9H,OL,OH,1L,1H	49-51
		353043-AS7 Fitting (lubricator)-straight-1/4"-28 x 1/2"	2	9L,9H,OL,OH,1L,1H	49-51
		353023-S7 Fitting (lubricator)-short-1/4"-28 x 1/2"-elbow type	2	9L,9H,OL,OH,1L,1H	49-51
		351059-S7 Nut (hex slotted)-1/2"-20	2	9L,9H,OL,OH,1L,1H	49-51
48 3287		Clamp (spindle connecting rod)	4	9L,9H,OL,OH,1L,1H	49-51
GM 3289	NS	End Assy (spindle conn. rod)-replaced by GM-3270 Kit	2	9L,9H,OL,OH,1L,1H	49-51
		72016-S Cotter pin-3/32" x 3/4"	2	9L,9H,OL,OH,1L,1H	49-51
		353043-AS7 Fitting (lubricator)-straight-1/4"-28 x 1/2"	2	9L,9H,OL,OH,1L,1H	49-51
		351059-S Nut (castle)-1/2"-20	2	9L,9H,OL,OH,1L,1H	49-51
GM 3304		Connecting link and ball stud Assy (steering)-idler arm to steering arm	1	9L,9H,OL,OH,1L,1H	49-51
		72016-S8 Cotter pin-3/32" x 1"	2	9L,9H,OL,OH,1L,1H	49-51
		353043-AS7 Fitting (lubricator)-straight-1/4"-28 x 1/2"	1	9L,9H,OL,OH,1L,1H	49-51
		351059-S7 Nut (hex slotted)-1/2"-20	2	9L,9H,OL,OH,1L,1H	49-51

# Lincoln and Lincoln Cosmopolitan

## CHASSIS PARTS CATALOGUE

PART NUMBER	PART NAME	NO. REQ'D	MODEL	YEAR
<b>Steering Linkage—Continued</b>				
11A 3310	Sleeve assy (drag link adjusting)	2	9L,9H,OL,OH,1L,1H	49-51
	20427-S8 Bolt (hex head)-5/16"-24 x 1-1/4"	4	9L,9H,OL,OH,1L,1H	49-51
	34443-S7 Locknut (hex)-5/16"-24	4	9L,9H,OL,OH,1L,1H	49-51
8M 3332	Seal (steering linkage ball stud)-Rubber	5	9L,9H,OL,OH,1L,1H	49-51
8M 3351	Support (steering idler arm)-to frame	1	9L,9H,OL,OH	49-50
1M 3351	Bracket (steering idler arm mounting)-to frame	1	1L,1H	51
	24391-S7 Bolt (hex head)-7/16"-20 x 1"	2	9L,9H,OL,OH,1L,1H	49-51
	34808-S8 Lockwasher-7/16"	2	9L,9H,OL,OH,1L,1H	49-51
HAK 3352-A	Kit (steering idler arm)-consists of the following (1) 8M-3355 Arm (2) 0M-3356 Bushing (2) 8M-3359 Seal (1) 353047-AS7 Fitting (1) 358011-S7 Fitting	1	9L,9H,OL,OH,1L,1H	49-51
8M 3355	Arm (steering idler)	1	9L,9H,OL,OH,1L,1H	49-51
8M 3356	Bushing assy (steering idler arm)-1-3/4" overall length	2	9L,9H,OL,OH	49-50
0M 3356	Bushing assy (steering idler arm)-2-1/16" overall length	2	9L,9H,OL,OH,1L,1H	49-51
	358011-S7 Fitting (lubricator)-1/8" x 90°-elbow type	1	9L,9H,OL,OH,1L,1H	49-51
	353047-AS7 Fitting (lubricator)-1/8" pipe thread-straight	1	9L,9H,OL,OH,1L,1H	49-51
8M 3359	Seal (steering idler arm)-Rubber	2	9L,9H,OL,OH,1L,1H	49-51

# Steering Gear

8H 3504-A	NS	Gear assy (steering)-with friction type bushings in steering gear case for sector shaft-47-13/32" long from threaded end of shaft to center of sector adjusting screw-replaced by 8H-3504-B	1	9H,OH	49-50
8H 3504-B		Gear assy (steering)-20.4 to 1 ratio-with needle point type bearings in steering gear case for sector shaft-47-13/32" long from threaded end of shaft to center of sector adjusting screw-tube has Yellow daub of paint identification marking	1	9H,OH	49-50
OH 3504		Gear assy (steering)-22.3 to 1 ratio-with needle point type bearings in steering gear case for sector shaft-47-13/32" long from threaded end of shaft to center of sector adjusting screw-tube has White daub of paint identification marking	1	9H,OH,1H	49-51
8L 3504-A	NS	Gear assy (steering)-with friction type bushings in steering gear case for sector shaft-48-7/8" long from threaded end of shaft to center of sector adjusting screw-repl. by OL-3504	1	9L,OL	49-50
8L 3504-B	NS	Gear assy (steering)-20.4 to 1 ratio-with needle point type bearings in steering gear case for sector shaft-48-7/8" long from threaded end of shaft to center of sector adjusting screw-tube has Yellow daub of paint identification marking-replaced by OL-3504	1	9L,OL	49-50
OL 3504		Gear assy (steering)-22.3 to 1 ratio-with needle point type bearings in steering gear case for sector shaft-48-7/8" long from threaded end of shaft to center of sector adjusting screw-tube has White daub of paint identification marking	1	9L,OL,1L	49-51

# Lincoln and Lincoln Cosmopolitan

## CHASSIS PARTS CATALOGUE

### Steering Gear—Continued

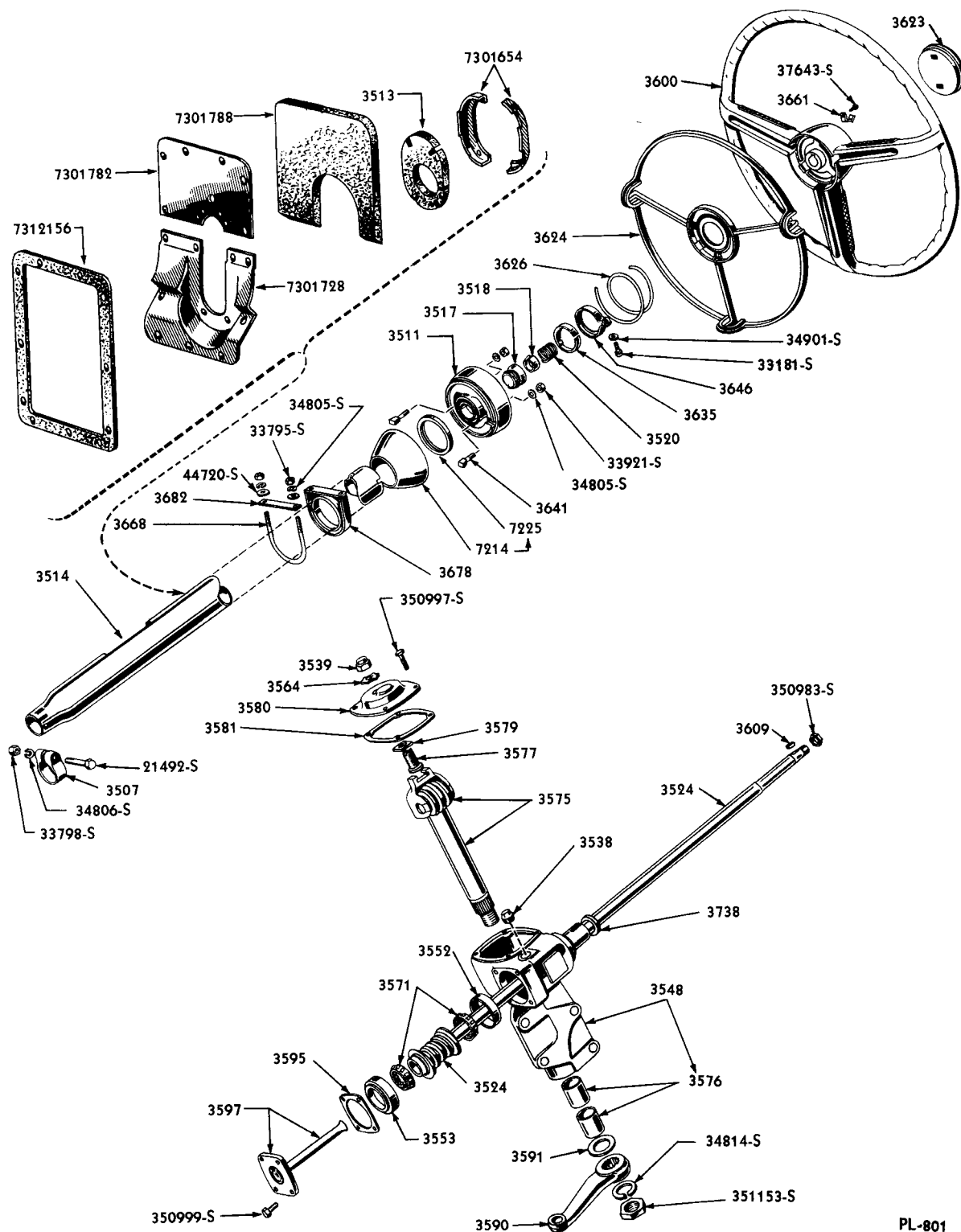

PL-801

### STEERING GEAR ASSEMBLY AND RELATED PARTS (W/O HYDRA-MATIC TRANSMISSION)

Basic numbers only shown on illustration. Order by Part Numbers shown in list of parts.

# Lincoln and Lincoln Cosmopolitan

## CHASSIS PARTS CATALOGUE

PART NUMBER	CLASS	PART NAME	NO. REQ'D	MODEL	YEAR
<b>Steering Gear—Continued</b>					
		350781-S8 Bolt (hex head pointed)-7/16" 20 x 4-1/4"-to frame	4	9L,9H,OL,OH,LL,1H	49-51
		34808-S8 Lockwasher-7/16"-to frame	3or4	9L,9H,OL,OH,LL,1H	49-51
		33802-S2 Nut (hex)-7/16"-20-to frame	3or4	9L,9H,OL,OH,LL,1H	49-51
		44730-S8 Washer (flat)-7/16"-to frame	4	9H,OH,1H	49-51
B 3507		Clamp (steering column)-at lower end of steering column tube	1	9L,9H,OL,OH,LL,1H	49-51
		21492-S2 Bolt (hex head)-5/16"-24 x 1-7/8"	1	9L,9H,OL,OH,LL,1H	49-51
		34806-S2 Lockwasher-5/16"	1	9L,9H,OL,OH,LL,1H	49-51
		33798-S8 Nut (hex)-5/16"-24	1	9L,9H,OL,OH,LL,1H	49-51
●8H 3509-BE		Flange assy (steering column tube)-in Prime-includes (1) 21A-3517 Bearing and (1) 8L-7225-B Bearing	1	9L,9H,OL,OH,LL,1H	49-51
*8H 3509-CP		Flange assy (steering column tube)-in Prime includes (1) 21A-3517 Bearing and (1) 8L-7225-C Bearing	1	9L,9H,OL,OH,LL,1H	49-51
*LL 3509-AP		Flange assy (steering column tube)-in Prime-with lugs	1	LL,1H	51
*8L 3511-AA	NS	Flange (steering column tube)-Gold Fleck Dark Gray Metallic Finish-repl. by 8M-3511-AE	1	9L,9H	49
*8M 3511-AE		Flange (steering column tube)-in Prime	1	9L,9H	49
		*8M-3641-A Wedge (steering column tube flange) -tapered wedge type	2	9L,9H	49
		**8M-3641-B Bolt (steering column tube flange)- hook type	2	9L,9H,OL,OH,LL,1H	49-51
		34805-S8 Lockwasher (external tooth)- 1/4"	2	9L,9H,OL,OH,LL,1H	49-51
		33921-S13 Nut (hex)-1/4"-28	2	9L,9H,OL,OH,LL,1H	49-51
8M 3513-A		Sealer (steering column opening weather)-Sponge Rubber	1	9L	49
8M 3513-B		Sealer (steering column opening weather)-Black Rubber with beaded collar at upper opening	1	OL,OH,LL,1H	50-51
		8M-7001654-A Retainer (steering column opening sealer)	2	9L	49
		8M-7001654-B Retainer (steering column opening sealer)	2	OL,OH,LL,1H	50-51
		42021-S7 Screw (hex head self tapping)- No. 10-12 x 3/4"	4	9L,OL,LL	49-51
		8M-7001698-A Plate (steering column to dash cover)-upper	1	9L	49
		8M-7001698-B Plate (steering column to dash cover)-upper	1	OL,LL	50-51

\* Use in steering gear assy with gear shift lever and insulator opening approximately 2-1/4" in length-cars without HYDRA-MATIC transmission

\*\* Use in steering gear assy with gear shift lever and insulator opening approximately 3-1/2" in length-also cars with HYDRA-MATIC transmission

● Use in steering gear assy with gear shift lever and insulator opening approximately 3-1/2" in length-also cars without HYDRA-MATIC transmission

+ Use with HYDRA-MATIC transmission

# Lincoln and Lincoln Cosmopolitan

## CHASSIS PARTS CATALOGUE

### Steering Gear—Continued

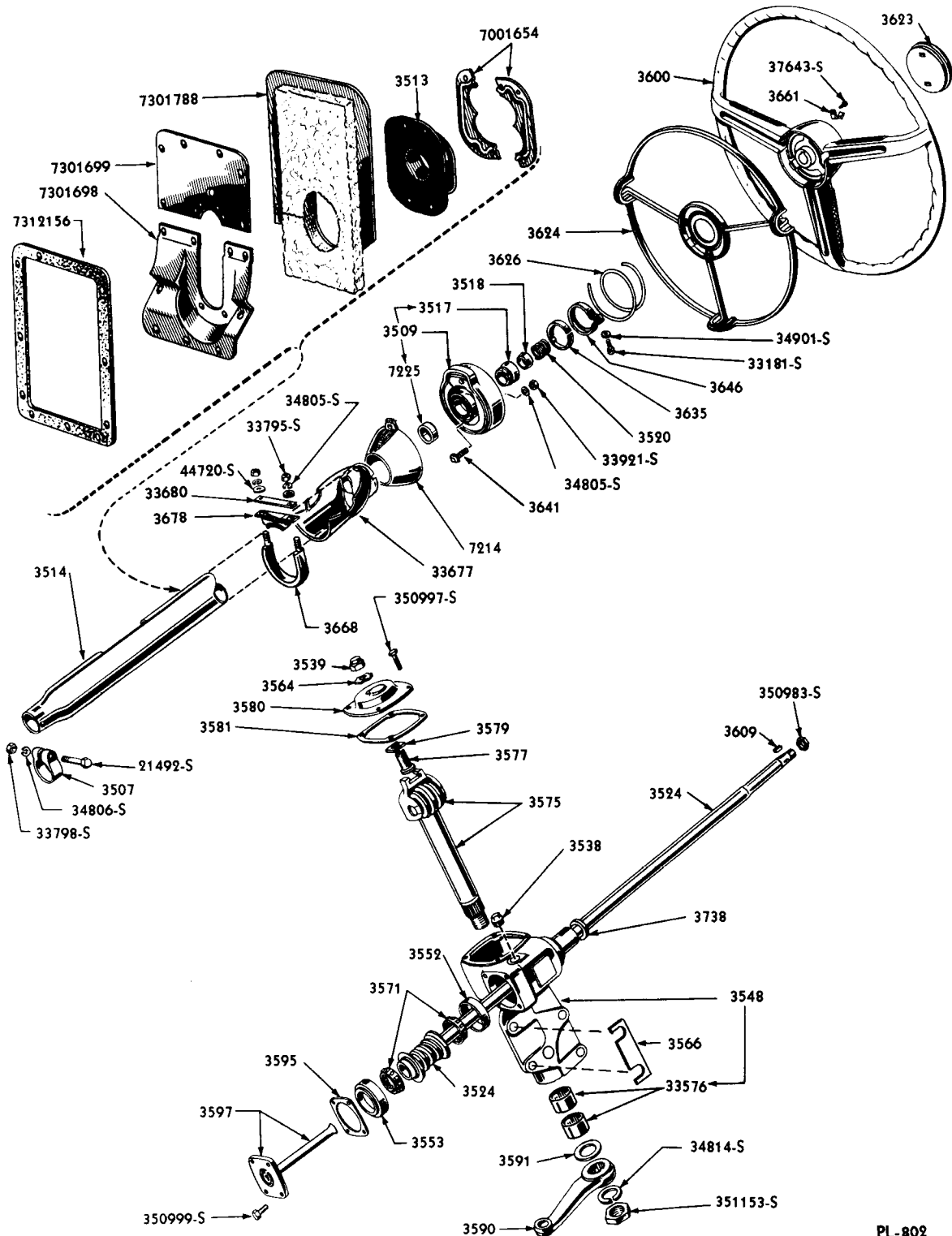

PL-802

### STEERING GEAR ASSEMBLY AND RELATED PARTS (HYDRA-MATIC TRANSMISSION)

Basic numbers only shown on illustration. Order by Part Numbers shown in list of parts.

# Lincoln and Lincoln Cosmopolitan

## CHASSIS PARTS CATALOGUE

PART NUMBER	C L A S S	PART NAME	NO. REQ'D	MODEL	YEAR 19
<b>Steering Gear—Continued</b>					
		8M-7001699-A Plate (steering column to dash cover)-lower	1	9L	49
		8M-7001699-B Plate (steering column to dash cover)-lower	1	0L,1L	50-51
		42014-S8 Screw (hex head self tapping)- No. 10-12 x 5/8"	6	9L,0L,1L	49-51
		8M-7012156-A Weatherstrip (steering column to dash cover plates)-Sprong Rubber -7-3/8" wide x 9-1/2" long x 3/4" wide x 9/64" thick	2	9L,0L,1L	49-51
7EH 3513		Sealer (steering column opening weather)-Sponge Rubber	1	9H	49
		7EH-7301654 Retainer (steering column opening sealer)-half oval shaped	2	9H	49
		42037-S8 Screw (hex-hd self tapping)- No. 10-12 x 1-1/4"	4	9H,0H,1H	49-51
		7EH-7301728 Plate (steering column to dash cover)-lower	1	9H	49
		8H-7301698 Plate (steering column to dash cover)-lower	1	0H,1H	50-51
		7EH-7301782 Plate (steering column to dash cover)-upper	1	9H	49
		8H-7301699 Plate (steering column to dash cover)-upper	1	0H,1H	50-51
		42014-S8 Screw (hex head self tapping)- No. 10-12 x 5/8"	13	9H,0H,1H	49-51
		8H-7301788-A Insulator (steering column to dash cover plate)-Sponge Rubber-8-1/8" wide x 8-7/8" long x 3/4" thick	1	9H	49
		0H-7301788 Insulator assy (steering column to dash cover plate)-8" wide x 11-7/8" long	1	0H,1H	50-51
		7EH-7312156 Weatherstrip (steering column dash cover plate)-Sponge Rubber- 7-25/32" wide x 12-5/16" long x 3/4" wide x 1/4" thick	1	9H,0H,1H	49-51
*8H 3514-AA		Tube & retainer assy (steering column)-Gold Fleck Dark Gray Metallic Finish-approx. 42-19/32" long 1-15/32" from upper end of tube to upper end of wiring slot	1	9H	49
*8L 3514-AA	NS	Tube & retainer assy (steering column)-Gold Fleck Dark Gray Metallic Finish-approx. 44-1/32" overall length-replaced by 8L-3514-AE	1	9L	49
*8H 3514-AE		Tube & retainer assy (steering column)-in Prime-approx. 42-19/32" o/all length-1-15/32" from upper end of tube to upper end of wiring slot	1	9H	49
*8L 3514-AE		Tube & retainer assy (steering column)-in Prime-approximately 44-1/32" overall length	1	9L	49

\* Use in steering gear assy with gear shift lever and insulator opening approximately 2-1/4" in length-not used with HYDRA-MATIC transmission

# Lincoln and Lincoln Cosmopolitan

## CHASSIS PARTS CATALOGUE

PART NUMBER	PART NAME	NO. REQ'D	MODEL	YEAR 19__
<b>Steering Gear—Continued</b>				
**8H 3514-BE	Tube assy (steering column)-in Prime-42-17/32" o/all length-16-7/8" from upper end of tube to lower end of wiring slot-2-21/64" from upper end of tube to upper end of wiring slot	1	9H,OH	49-50
**8L 3514-BE	Tube assy (steering column)-in Prime-43-31/32" o/all length-16-7/8" from upper end of tube to lower end of wiring slot	1	9L,OL	49-50
**OH 3514-AP	Tube assy (steering column)-in Prime-42-17/32" o/all length-19-7/8" from upper end of tube to lower end of wiring slot	1	OH,1H	50-51
**OL 3514-AP	Tube assy (steering column)-in Prime-43-31/32" o/all length-19-7/8" from upper end of tube to lower end of wiring slot	1	OL,1L	50-51
+8H 3514-CP	Tube assy (steering column)-in Prime-42-17/32" overall length-16-7/8" from upper end of tube to lower end of wiring slot	1	9H	49
+8L 3514-CP	Tube assy (steering column)-in Prime-43-31/32" overall length-16-7/8" from upper end of tube to lower end of wiring slot	1	9L	49
+OH 3514-BP	Tube assy (steering column)-in Prime-42-17/32" overall length with 5/16" slot at top of tube	1	OH,1H	50-51
+OL 3514-BP	Tube assy (steering column)-in Prime-43-31/32" overall length with 5/16" slot at top of tube	1	OL,1L	50-51
+1H 3514-AP	Tube assy (steering column)-in Prime-42-17/32" over- all length-19-7/8" from upper end of tube to lower end of wiring slot-with 39/64" tapered slot at top of tube	1	1H	51
+1L 3514-AP	Tube assy (steering column)-in Prime-43-31/32" over- all length-19-7/8" from upper end of tube to lower end of wiring slot-with 39/64" tapered slot at top of tube	1	1L	51
	OH-33677-A Boot (steering column to instrument panel)-Rubber-replaced by OH-33677-B	1	OH	50
	OH-33677-B Boot (steering column to instrument panel)-Rubber-Light Gray	1	OH	50
	OL-33677-A Boot (steering column to instrument panel)-Rubber-replaced by OL-33677-B	1	OL	50
	OL-33677-B Boot (steering column to instrument panel)-Rubber-Light Gray	1	OL	50

+ Used with HYDRA-MATIC transmission

\*\* Use in steering gear assy with gear shift lever and insulator opening approximately 3-1/2" in length-not used with HYDRA-MATIC transmission



# Lincoln and Lincoln Cosmopolitan

## CHASSIS PARTS CATALOGUE

PART NUMBER	PART NAME	NO. REQ'D	MODEL	YEAR 19
<b>Steering Gear—Continued</b>				
21A 3517	Bearing assy (steering column)-upper-1.442"/1.445" O.D. with 22 round balls	1	9L,9H,OL,OH,1L,1H	49-51
8M 3518	Sleeve (steering column bearing)-upper-tapered-with 3/32" width slot	1	9L,9H,OL,OH,1L,1H	49-51
8M 3520	Spring (steering column bearing)-upper-25/32" I.D. x 29/32" overall free length	1	9L,9H,OL,OH,1L,1H	49-51
8H 3524	Shaft & worm assy (steering column)-20.4 to 1 ratio-49-5/32" overall length-used with 8L-3575-B	1	9H,OH	49-50
OH 3524	Shaft & worm assy (steering column)-22.3 to 1 ratio-49-5/32"-overall length-used with OL-3575-B -with White daub of paint	1	OH,1H	50-51
8L 3524	Shaft & worm assy (steering column)-20.4 to 1 ratio-50-39/64" overall length-used with 8L-3575-B	1	9L,OL	49-50
OL 3524	Shaft & worm assy (steering column)-22.3 to 1 ratio-50-39/64"-overall length-used with OL-3575-B -with White daub of paint	1	OL,1L	50-51
	350983-S Nut (hex thin)-5/8"-18	1	9L,9H,OL,OH,1L,1H	49-51
B 3538	Plug (steering gear oil filler)-3/4"-20 tapered thread x 5/8" hex head	1	9L,9H,OL,OH,1L,1H	49-51
78 3539-A	Locknut assy (steering thrust screw)-1/2"-20 tapped hole x 3/4" hex	1	9L,9H,OL,OH,1L,1H	49-51
8L 3548-A	NS Housing and bushing assy (steering gear)-with friction type bushings for sector shaft-replaced by 8L-3548-B	1	9L,9H,OL,OH	49-50
8L 3548-B	Housing and bearing assy (steering gear)-with needle point type bearings for sector shaft	1	9L,9H,OL,OH,1L,1H	49-51
	8L-33576 Bearing (steering gear shaft)- needle point rollers type	2	9L,9H,OL,OH,1L,1H	49-51
BB 3552	Cup (steering gear worm bearing)-upper-29/64" wide x 1-15/16" O.D.	1	9L,9H,OL,OH,1L,1H	49-51
81T 3553	Cup (steering gear worm bearing)-lower-11/16" wide x 2-1/4" O.D.	1	9L,9H,OL,OH,1L,1H	49-51
78 3564	Washer (steering thrust screw lock)-6 pointed with lettering "This Side Up"	1	9L,9H,OL,OH,1L,1H	49-51
OL 3566-A	Spacer (steering gear housing to frame)-between strg. housing and frame for alignment	as reqd	OL,OH,1L,1H	50-51
81T 3568-B	NS Plate (steering gear housing end)-order O1T-3597-B	1	9L,9H,OL,OH	49-50
81T 3571-A	Roller assy (steering gear worm bearing)	2	9L,9H,OL,OH,1L,1H	49-51
8L 3575-B	Shaft assy (steering gear sector)-20.4 to 1 ratio-stamped "05"-used with 8L-3524 and 8H-3524	1	9L,9H,OL,OH	49-50
OL 3575-A	NS Shaft assy (steering gear sector)-22.3 to 1 ratio- without needle point bearing-repl. by OL-3575-B	1	OL,OH,1L,1H	50-51
OL 3575-B	Shaft assy (steering gear sector)-22.3 to 1 ratio- with needle point bearing	1	OL,OH,1L,1H	50-51

# Lincoln and Lincoln Cosmopolitan

## CHASSIS PARTS CATALOGUE

PART NUMBER	CLASS	PART NAME	NO. REQ'D	MODEL	YEAR 19 _____
<b>Steering Gear—Continued</b>					
81T 3576-A	NS	Bushing (steering worm sector)-1-5/16" O.D. x 1-3/16" overall length-replaced by 7RT-3576-A	2	9L,9H	49
7RT 3576-A		Bushing (steering worm sector)-1-5/16" O.D. x 1-5/16" overall length-used with 8L-3548-A Hsg.	2	9L,9H,OL,OH	49-50
78 3577		Screw (steering sector shaft thrust)-1/2"-20 x 1-1/4" overall length	1	9L,9H,OL,OH,LL,LH	49-51
7RT 3579		Washer (steering sector shaft thrust)-.760" wide x .880" long x .520" dia hole x .082"/.083" thick	1	9L,9H,OL,OH,LL,LH	49-51
7RT 3580		Cover (steering gear housing)-with tapped hole for adjustment screw	1	9L,9H,OL,OH,LL,LH	49-51
		350997-S Screw (special hex head)-5/16"- 18 x 9/16"	4	9L,9H,OL,OH,LL,LH	49-51
7RT 3581		Gasket (steering gear housing cover)-Asbestos with four 11/32" diameter holes	1	9L,9H,OL,OH,LL,LH	49-51
8M 3582		Plug (steering gear worm cover)-1-7/32" O.D. x 17/64" overall thickness-depressed type	1	9L,9H,OL,OH,LL,LH	49-51
8M 3590		Arm (steering gear)	1	9L,9H,OL,OH,LL,LH	49-51
		34814-S Lockwasher-7/8"	1	9L,9H,OL,OH,LL,LH	49-51
		351153-S Nut (hex slotted)-7/8"-14	1	9L,9H,OL,OH,LL,LH	49-51
8M 3591		Seal assy (steering gear housing oil)-1-15/64" I.D. x 1-43/64" O.D. steel washer bonded to Synthetic Rubber	1	9L,9H,OL,OH,LL,LH	49-51
81T 3593	NS	Gasket (steering gear housing cap)-upper-.005"-.006" thick-replaced by 81T-3595	as reqd	9L,9H	49
81T 3594	NS	Gasket (steering gear housing end plate)-.010"-.012" thick-replaced by 81T-3595	as reqd	9L,9H	49
81T 3595		Gasket (steering gear housing end plate)-.002"-.003" thick-Paper	as reqd	9L,9H,OL,OH,LL,LH	49-51
OLT 3597-B		Plate assy (steering gear housing end)	1	9L,9H,OL,OH,LL,LH	49-51
		350999-S Screw (spec. hex-hd)-5/16"-18 x 3/4"-cover to strg. gear hsg.	4	9L,9H,OL,OH,LL,LH	49-51
8L 3600-AA		Wheel assy (steering)-Gold Fleck Dark Gray Metallic Finish	1	9L,9H	49
8H 3600-AB		Wheel assy (steering)-Green plastic & Prime skirt- use on cars with Green interiors	1	9L,9H	49
8H 3600-AC		Wheel assy (steering)-Blue plastic & Prime skirt- use on cars with Blue interiors	1	9L,9H	49
8H 3600-AD		Wheel assy (steering)-Tan plastic & Prime skirt- use on cars with Tan, Maroon or Yellow interiors	1	9L,9H	49
OL 3600-A	NS	Wheel assy (steering)-Black rim and Light Gray Metallic hub-replaced by 1L-3600-A	1	OL,OH	50
OL 3600-B		Wheel assy (steering)-Black rim and Gray finish hub	1	OL,OH	50
OL 3600-C	NS	Wheel assy (steering)-Black rim and Chrome hub-with cross line design spokes-replaced by (1) 1L-3600-A and (1) 1L-3623	1	OL72C,OH72C	50
1L 3600-A		Wheel assy (steering)-Black rim and Chrome hub- with parallel line design spokes	1	OL,OH,LL,LH	50-51
1L 3600-B		Wheel assy (steering)-Oyster White rim and Chrome hub-with parallel line design spokes	1	1L72C,1H72C	51
		7CM-3661 Spring (steering wheel emblem)	2	9L,9H,OL,OH	49-50
		1L-3661 Clip (steering wheel emblem)	2	1L,1H	51
		37643-S7 Screw (Phillister head)-No. 6- 32 x 7/16"	2	9L,9H,OL,OH,LL,LH	49-51

# Lincoln and Lincoln Cosmopolitan

## CHASSIS PARTS CATALOGUE

PART NUMBER	PART NAME	NO. REQ'D	MODEL	YEAR
<b>Steering Gear—Continued</b>				
B 3609	Key (woodruff)-No. 9-.240"/.245" depth x .1875"/.1885" thick-wheel to steering gear tube	1	9L,9H,OL,OH,1L,1H	49-51
8L 3623-AA	Cap & emblem assy (steering wheel)-Gold Fleck Derk Gray Metallic Finish	1	9L,9H	49
8L 3623-AB	Cap & emblem assy (steering wheel)-Green-use on cars with Green interiors-Gold emblem	1	9L,9H	49
8L 3623-AC	Cap & emblem assy (steering wheel)-Blue-use on cars with Blue interiors-Gold emblem	1	9L,9H	49
8L 3623-AD	Cap & emblem assy (steering wheel)-Tan-use on cars with Tan, Maroon or Yellow interiors-Gold emblem	1	9L,9H	49
OL 3623-A	Cap and emblem assy (steering wheel)-Light grey metallic-Chrome emblem	1	OL,OH	50
OL 3623-B	Cap and emblem assy (steering wheel)-Black Metallic-Bright Gold emblem	1	OL72C,OH72C	50
1L 3623	Cap and emblem assy (steering wheel)	1	1L,1H	51
	51754-S8 Screw (cross-recessed)-No. 6-32 x 3/8"	4	1L,1H	51
8L 3624	Ring (horn)-31/32" from ring face to hub face	1	9L,9H	49
OL 3624	Ring (horn)-1-1/32" from ring face to hub face	1	9L,9H,OL,OH	49-50
1L 3624	Ring (horn)-with 5/8" long slot	1	1L,1H	51
8M 3626-A	Spring (horn ring)-.120" diameter spring wire	1	9L,9H,OL,OH,1L,1H	49-51
8M 3626-B	Spring (horn ring)-.127" diameter spring wire	1	9L,9H	49
8M 3635	Insulator (horn wire terminal)-Fibre	1	9L,9H,OL,OH,1L,1H	49-51
*8M 3641-A	Wedge (steering column tube flange)-tapered wedge type	2	9L,9H	49
**8M 3641-B	Bolt (steering column tube flange)-hook type-1/4"-28	2	9L,9H,OL,OH,1L,1H	49-51
	34805-S8 Lockwasher-1/4"	2	9L,9H,OL,OH,1L,1H	49-51
	34081-S7 Nut (hex)-1/4"-28	2	9L,9H,OL,OH,1L,1H	49-51
8M 3646	Support (horn button wire contact)	1	9L,9H,OL,OH,1L,1H	49-51
	34901-S7 Lockwasher (internal tooth)-No. 6	1	9L,9H,OL,OH,1L,1H	49-51
	33181-S7 Screw (binding head self tap.)-No. 6-20 x 1/2"	1	9L,9H,OL,OH,1L,1H	49-51
7CM 3661	Spring (steering wheel emblem)-retains cap and emblem to wheel-1/2" wide x 11/16" long x 19/32" high	2	9L,9H,OL,OH	49-50
1L 3661	Clip (steering wheel emblem)-retains cap and emblem to wheel-19/64" wide x 25/32" long	2	1L,1H	51
	37643-S7 Screw (fillister head)-No. 6-32 x 7/16"	2	9L,9H,OL,OH,1L,1H	49-51
8L 3667	Spacer (steering column housing to fender apron)-Sponge Rubber-2" x 2-1/2" x 1/4" thick	1	9L,9H,OL,OH,1L,1H	49-51
8M 3668	Bolt (steering column bracket "U")-1/4"-20-without Rubber insulation	1	9L,9H	49
OL 3668-C	Bolt (steering column to instrument panel "U")-1/4"-20-threads-with Gray Rubber insulation	1	OL,OH	50
1M 3668-A	Bolt (steering column to instrument panel "U")-1/4"-20 threads with Platinum Rubber insulation	1	1L,1H	51

\* Use in steering gear assy with gear shift lever and insulator opening approximately 2-1/4" in length-not used with HYDRA-MATIC transmission

\*\* Use in steering gear assy with gear shift lever and insulator opening approximately 3-1/2" in length-also cars with HYDRA-MATIC transmission

# Lincoln and Lincoln Cosmopolitan

## CHASSIS PARTS CATALOGUE

PART NUMBER	QUANTITY	PART NAME	NO. REQ'D	MODEL	YEAR 19__
<b>Steering Gear—Continued</b>					
1M 3668-B		Bolt (steering column bracket "U")-1/4"-20-with Black Rubber insulation	1	9L,9H,OL,OH	49-50
		34805-S8 Lockwasher-1/4"	2	9L,9H,OL,OH,1L,1H	49-51
		33795-S7 Nut (hex)-1/4"-20	2	9L,9H,OL,OH,1L,1H	49-51
		44720-S8 Washer (flat)-1/4"	2	9L,9H,OL,OH,1L,1H	49-51
8L 3678-AA		Bracket (steering column)-Gold Fleck-Dark Gray Metallic Finish	1	9L,9H	49
8M 3678-AE		Bracket (steering column)-in Prime	1	9L,9H	49
OL 3678		Saddle assy (steering column "U" bolt)	1	OL,OH,1L,1H	50-51
		OL-33680 Anti squeak (strg. column saddle)- Fibre	1	OL,OH,1L,1H	50-51
8L 3682		Shim (steering column bracket)-Rubber-49/64" wide x 3-1/4" long x 3/32" thick	1	9L,9H	49
8M 3682		Shim (steering column bracket)-Paper	1	9L,9H	49
OL 3682	NS	Insulator (steering column saddle)-11/16" wide x 1-7/8" long x 1/8" thick-make locally	1	OL,OH,1L,1H	50-51
8H 3685		Key (ignition and door lock)	2	9L,9H,OL,OH,1L,1H	49-51
		8H-11582-A Cylinder and keys (ign. switch lock)	1	9L,9H,OL,OH	49-50
		8H-11582-B Cylinder and keys (ign. switch lock)	1	9L,9H,OL,OH,1L,1H	49-51
		8H-18306 Key (glove compartment and rear deck compartment lock)	2	9L,9H,OL,OH,1L,1H	49-51
8L 3687-A		Lock set assy (primary)-consists of ignition lock cylinder with keys & door lock cylinder and sleeve	1	9L	49
8H 3687-A	NS	Lock set assy (primary)-consists of ignition lock cylinder with keys & door lock cylinder & sleeve -replaced by OH-3687-A	1	9H	49
OH 3687-A		Lock set assy (primary)-consists of ignition lock cyl. with keys and door lock cylinder and sleeve	1	9L,OH	49-50
OH 3687-B		Lock set assy (primary)-consists of ignition lock cylinder with keys and door lock cylinder & sleeve	1	1H	51
OM 3687-A		Lock set assy (primary)-consists of ignition lock cyl. with keys and door lock cylinder and sleeve	1	OL72-74	50
OM 3687-C		Lock set assy (primary)-consists of ignition lock cylinder with keys and door lock cylinder & sleeve	1	1L	51
		355114-S7 Screw (headless set)-No. 10-32 x 1/2"	2	9L,9H,OL,OH,1L,1H	49-51
8L 3689-A		Lock set assy (secondary)-has glove compt. lock with oblong face plate-consists of glove compt. lock assy with keys and rear deck lock cylinder	1	9L	49
8H 3689-A		Lock set assy (secondary)-has glove compt. lock with oblong face plate-consists of glove compt. lock assy with keys and rear deck lock cylinder	1	9H	49
OL 3689-A		Lock set assy (secondary)-consists of glove compt. lock assy with keys and rear deck lock cylinder	1	OL,OH	50
OL 3689-B		Lock set assy (secondary)-has glove compartment lock with oblong face plate-consists of glove compt. lock assy with keys and rear deck lock cylinder	1	OL,OH,1L,1H	50-51
7RT 3738		Washer (steering shaft)-Felt-27/32" I.D. x 1-5/16" O.D. x 3/16" thick	1	9L,9H,OL,OH,1L,1H	49-51
8L 3765		Bracket (ignition switch light)	1	9L,9H	49
		33169-S8 Screw (pan head self tap.)- No. 8-32 x 1/4"-bracket to instrument panel	1	9L,9H	49

*Lincoln and Lincoln Corporation*  
CHASSIS PARTS CATALOGUE

Rear Axle

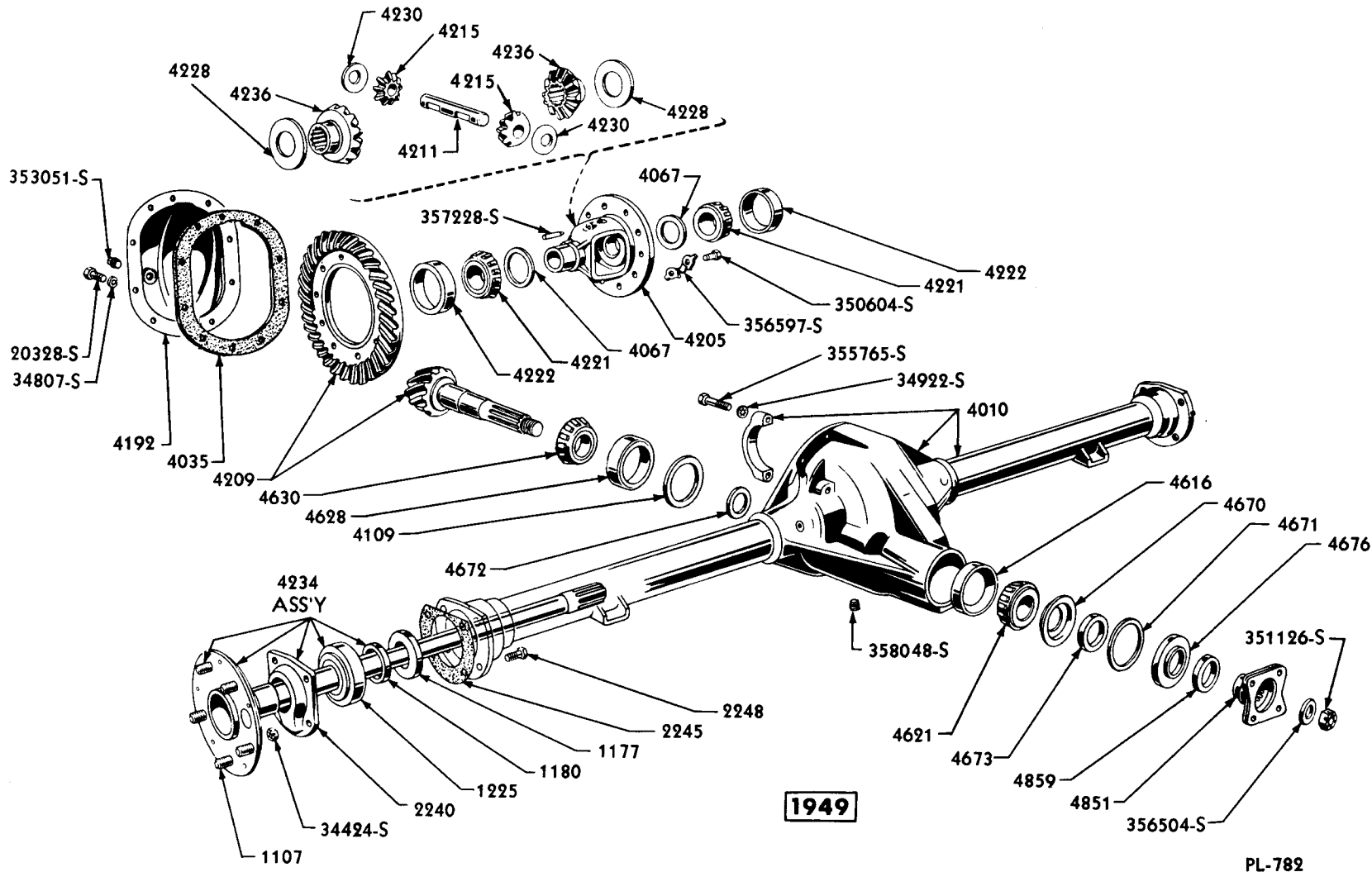

REAR AXLE

Basic numbers only shown on illustration. Order by Part Numbers shown in list of parts.

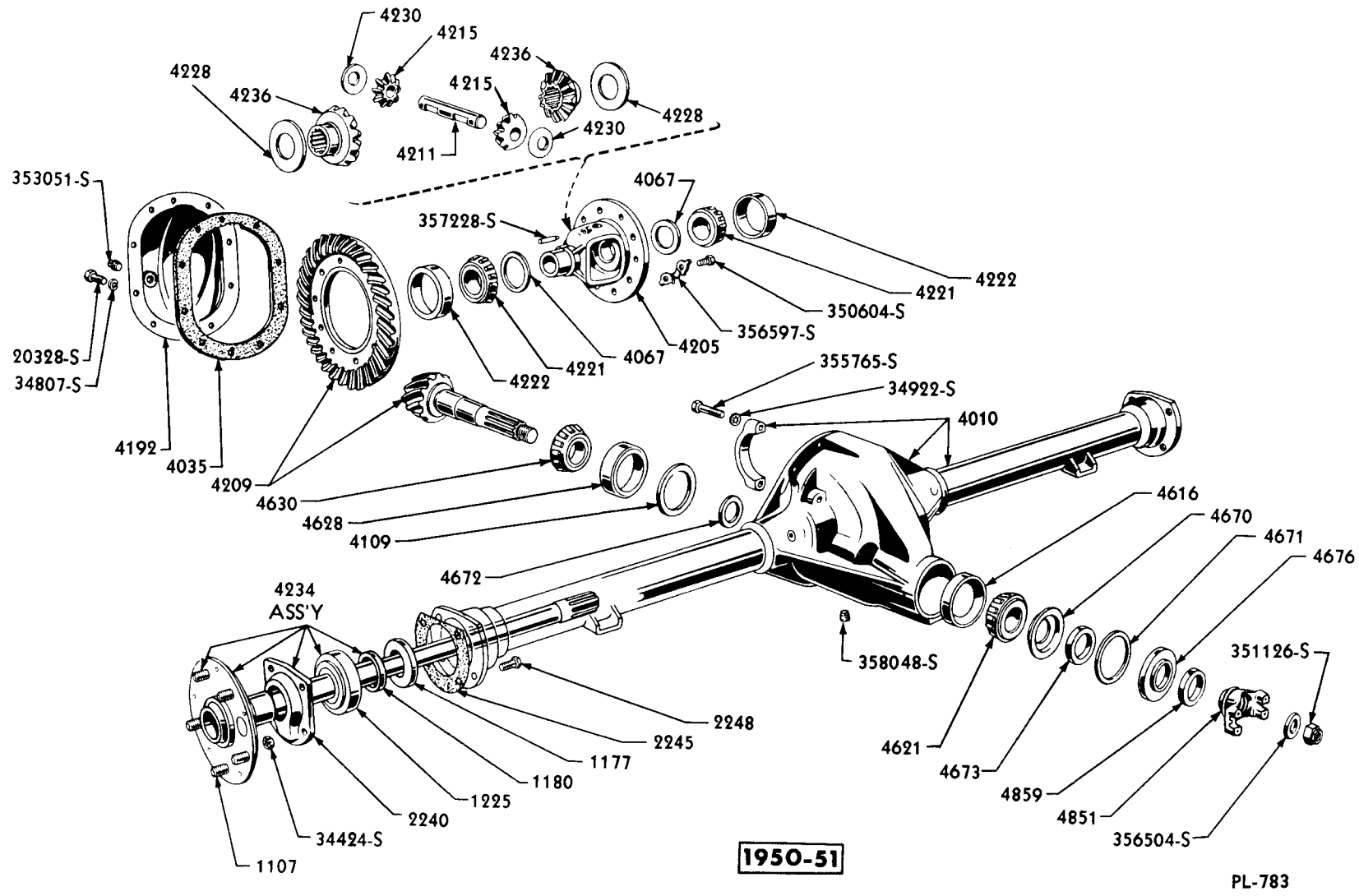

1950-51

PL-783

**REAR AXLE**

Basic numbers only shown on illustration. Order by Part Numbers shown in list of parts.

# Lincoln and Lincoln Cosmopolitan

## CHASSIS PARTS CATALOGUE

PART NUMBER	PART NAME	NO. REQ'D	MODEL	YEAR
<b>Rear Axle—Continued</b>				
††8H 4006-B	Axle assy (rear)-less brakes & axle shafts-4.27 to 1 ratio-uses flat face type flange assy (8L-4851-A)- attached to drive shaft with (4) hex head bolts	1	9H	49
†8H 4006-C	Axle assy (rear)-less brakes & axle shafts-3.31 to 1 ratio-uses flat face type flange assy (8L-4851-A)- attached to drive shaft with (4) hex head bolts	1	9H,OH	49-50
††8L 4006-A	Axle assy (rear)-less brakes & axle shafts 3.91 to 1 ratio-uses flat face type flange assy (8L-4851-A)- attached to drive shaft with (4) hex head bolts	1	9L	49
††8L 4006-B	Axle assy (rear)-less brakes & axle shafts-4.27 to 1 ratio-uses flat face type flange assy (8L-4851-A) attached to drive shaft with (4) hex head bolts	1	9L	49
†8L 4006-C	Axle assy (rear)-less brakes & axle shafts-3.31 to 1 ratio-uses flat face type flange assy (8L-4851-A)- attached to drive shaft with (4) hex head bolts	1	9L,OL	49-50
††1H 4006-B	Axle assy (rear) less brakes and axle shafts-4.27 to 1 ratio-uses offset face type flange assy (8C-4851)-connected by (2) "U" bolts (01Y-5429) to drive shaft	1	9H,OH,1H	49-51
†1H 4006-C	Axle assy (rear)-less brakes and axle shafts-3.31 to 1 ratio-uses offset face type flange assy (8C-4851)-connected by 2" "U" bolts (01Y-4529) to drive shaft	1	OH,1H	50-51
††1L 4006-A	Axle assy (rear) less brakes and axle shaft-3.91 to 1 ratio-uses offset face type flange assy (8C-4851)-connected by (2) "U" bolts (01Y-5429) to drive shaft	1	9L,OL,1L	49-51
††1L 4006-B	Axle assy (rear) less brakes and axle shafts-4.27 to 1 ratio-uses offset face type flange assy (8C-4851)-connected by (2) "U" bolts (01Y-5429) to drive shaft	1	9L,OL,1L	49-51
†1L 4006-C	Axle assy (rear)-less brakes and axle shafts-3.31 to 1 ratio-uses offset face type flange assy (8C-4851)-connected by 2 "U" bolts (01Y-4529) to drive shaft	1	OL,1L	50-51

† Used with HYDRA-MATIC transmission

†† Not used with HYDRA-MATIC transmission

# Lincoln and Lincoln Cosmopolitan

## CHASSIS PARTS CATALOGUE

### Rear Axle—Continued

#### REAR AXLE CHART

PART NUMBER	CLASS	PART NAME	REAR AXLE																		
			++8H-4006-B	+8H-4006-C	++8L-4006-A	++8L-4006-B	+8L-4006-C	++1H-4006-B	+1H-4006-C	++1L-4006-A	++1L-4006-B	+1L-4006-C									
			NUMBER REQUIRED																		
8H 4010		Housing assy (rear axle)-7-5/8" from face of flange to center line of spring pad -4-1/16" width spring pad	1	1																	
8L 4010		Housing assy (rear axle)-5-1/4" from face of flange to center line of spring pad -3-15/16" width spring pad			1	1	1														
OH 4010		Housing assy (rear axle)-7-5/8" from face of flange to center line of spring pad-1-7/8" width spring pad	1	1					1	1											
OL 4010		Housing assy (rear axle)-5-1/4" from face of flange to center line of spring pad-1-15/16" width spring pad			1	1	1					1	1	1							
		OM-2245 Gasket (wheel bearing retainer)-Paper	2	2	2	2	2	2	2	2	2	2	2	2	2	2	2	2	2	2	2
		OM-1177-B Seal assy (rear wheel inner oil)-with flanged metal reinforcement	2	2	2	2	2	2													
		OM-1177-A Seal assy (wheel bearing inner oil)-1/4" thick	2	2	2	2	2	2	2	2	2	2	2	2	2	2	2	2	2	2	2
		355765-S Bolt (hex-hd)-1/2"-13 x 2-1/4"-cap to differential case	4	4	4	4	4	4	4	4	4	4	4	4	4	4	4	4	4	4	4
		34922-S Lockwasher (internal tooth)-1/2"	4	4	4	4	4	4	4	4	4	4	4	4	4	4	4	4	4	4	4
		358048-S Pipe plug-3/4"-drain	1	1	1	1	1	1	1	1	1	1	1	1	1	1	1	1	1	1	1
8L 4033	NS	Cover assy (rear axle carrier)-with clip-replaced by 8L-4192	1	1	1	1	1	1													
8L 4035		Gasket (rear axle carrier cover)	1	1	1	1	1	1	1	1	1	1	1	1	1	1	1	1	1	1	1
8L 4067-A		Shim (differential bearing adjusting)-.0025"/.0035" thick	as reqd	as reqd	as reqd	as reqd	as reqd	as reqd	as reqd	as reqd	as reqd	as reqd	as reqd	as reqd	as reqd	as reqd	as reqd	as reqd	as reqd	as reqd	as reqd
8L 4067-B		Shim (differential bearing adjusting)-.0045"/.0055" thick	as reqd	as reqd	as reqd	as reqd	as reqd	as reqd	as reqd	as reqd	as reqd	as reqd	as reqd	as reqd	as reqd	as reqd	as reqd	as reqd	as reqd	as reqd	as reqd
8L 4067-C		Shim (differential bearing adjusting)-.009"/.011" thick	as reqd	as reqd	as reqd	as reqd	as reqd	as reqd	as reqd	as reqd	as reqd	as reqd	as reqd	as reqd	as reqd	as reqd	as reqd	as reqd	as reqd	as reqd	as reqd
8L 4067-D		Shim (differential bearing adjusting)-.027"/.033" thick	as reqd	as reqd	as reqd	as reqd	as reqd	as reqd	as reqd	as reqd	as reqd	as reqd	as reqd	as reqd	as reqd	as reqd	as reqd	as reqd	as reqd	as reqd	as reqd
*8H 4078		Control assy (transmission overdrive)-special equipment	Refer to Basic Number 6903																		
*8L 4078		Control assy (transmission overdrive)-special equipment	Refer to Basic Number 6903																		
OM 4078		Control assy (transmission overdrive)-special equipment	Refer to Basic Number 6903																		

\* Used with but not part of Basic number 4006 assembly

+ Used with HYDRA-MATIC transmission

++ Not used with HYDRA-MATIC transmission



# Lincoln and Lincoln Cosmopolitan

## CHASSIS PARTS CATALOGUE

### Rear Axle—Continued

#### REAR AXLE CHART—CONTINUED

PART NUMBER	CLASS	PART NAME	REAR AXLE												
			++8H-4006-B	+8H-4006-C	++8L-4006-A	++8L-4006-B	+8L-4006-C	++1H-4006-B	+1H-4006-C	++1L-4006-A	++1L-4006-B	+1L-4006-C			
			NUMBER REQUIRED												
8L 4109-A		Shim (driving pinion rear bearing adj.)-.0025"/.0035" thick	as reqd	as reqd	as reqd	as reqd	as reqd	as reqd	as reqd	as reqd	as reqd	as reqd	as reqd	as reqd	as reqd
8L 4109-B		Shim (driving pinion rear bearing adj.)-.0045"/.0055" thick	as reqd	as reqd	as reqd	as reqd	as reqd	as reqd	as reqd	as reqd	as reqd	as reqd	as reqd	as reqd	as reqd
8L 4109-C		Shim (driving pinion rear bearing adj.)-.009"/.011" thick	as reqd	as reqd	as reqd	as reqd	as reqd	as reqd	as reqd	as reqd	as reqd	as reqd	as reqd	as reqd	as reqd
OL 4120		Bracket (O/Drive control to instr. panel)	Refer to Basic Number 6903												
8L 4192		Cover (rear axle carrier)-without clip	1	1	1	1	1	1	1	1	1	1	1	1	1
		20328-S Bolt (hex-hd)-3/8"-16 x 5/8"	9	9	9	9	9	9	9	9	9	9	9	9	9
		34807-S2 Lockwasher-3/8"	9	9	9	9	9	9	9	9	9	9	9	9	9
		353051-S Plug (extended head pipe)-3/4"-filler	1	1	1	1	1	1	1	1	1	1	1	1	1
8L 4205-A		Case (differential gear)-11/32" from inside face of ring gear flange to center line of differential pinion shaft hole	1		1	1		1			1	1			
8L 4205-B		Case (differential gear)-1-5/8" from inside face of ring gear flange to center line of differential pinion shaft hole		1			1		1					1	
		357228-S Pin (spec. lock)-15/64" x 1-7/16"	1	1	1	1	1	1	1	1	1	1	1	1	1
8L 4209-A		Ring gear & pinion (rear axle)-matched set 3.91 to 1 ratio			1							1			
8L 4209-B		Ring gear & pinion (rear axle)-matched set 4.27 to 1 ratio	1			1		1					1		
8L 4209-C		Ring gear & pinion (rear axle)-matched set 3.31 to 1 ratio		1			1		1					1	
8L 4209-F		Ring gear & pinion (rear axle)-matched set 4.27 to 1 ratio	1			1		1					1		
		350604-S Bolt (hex-hd)-7/16"-20 x 15/16"	12	12	12	12	12	12	12	12	12	12	12	12	12
		356597-S Plate (locking)-ring gear to diff. case	6	6	6	6	6	6	6	6	6	6	6	6	6
8L 4211		Shaft (differential pinion)	1	1	1	1	1	1	1	1	1	1	1	1	1
8M 4215		Pinion (differential)-small-10 teeth	2	2	2	2	2	2	2	2	2	2	2	2	2
8L 4221		Cone & roller assy (rear axle diff.)	2	2	2	2	2	2	2	2	2	2	2	2	2
8L 4222		Cup (rear axle differential bearing)	2	2	2	2	2	2	2	2	2	2	2	2	2

+ Used with HYDRA-MATIC transmission

++ Not used with HYDRA-MATIC transmission

# Lincoln and Lincoln Cosmopolitan

## CHASSIS PARTS CATALOGUE

### Rear Axle—Continued

#### REAR AXLE CHART—CONTINUED

PART NUMBER	CLASS	PART NAME	REAR AXLE												
			††8H-4006-B	†8H-4006-C	††8L-4006-A	††8L-4006-B	†8L-4006-C	††1H-4006-B	†1H-4006-C	††1L-4006-A	††1L-4006-B	†1L-4006-C			
			NUMBER REQUIRED												
8L 4228		Washer (differential gear thrust)	2	2	2	2	2	2	2	2	2	2	2	2	
8M 4230		Washer (differential pinion thrust)	2	2	2	2	2	2	2	2	2	2	2	2	
★8L 4234-B		Shaft & bearing assy (rear axle)-with cardboard protector tubes	2	2	2	2	2	2	2	2	2	2	2	2	
		★8M-1225-B Bearing (rear wheel)	2	2	2	2	2	2	2	2	2	2	2	2	
		★8M-1107 Bolt (rd-hd spec.)-1/2"-20 x 1-5/16"-rear axle shaft to drum	10	10	10	10	10	10	10	10	10	10	10	10	
		★8M-1180 Retainer (rear wheel brg.) -inner-1-17/32" I.D. x 2-1/8" O.D. x 3/8" thick	2	2	2	2	2	2	2	2	2	2	2	2	
		★8M-2240 Retainer (rear wheel brg.) -2-1/4" I.D. x 4-3/8" wide	2	2	2	2	2	2	2	2	2	2	2	2	
		★8M-2248 Bolt (spec-hd)-1/2"-20 x 1-1/8"-rear axle brake housing	8	8	8	8	8	8	8	8	8	8	8	8	
		★34424-S7 Locknut (hex)-1/2"-20	8	8	8	8	8	8	8	8	8	8	8	8	
8L 4236		Gear (differential side)-large-16 teeth-20 splines	2	2	2	2	2	2	2	2	2	2	2	2	
8L 4296		Clip (overdrive control cable)	Refer to Basic Number 6903												
★01Y 4529		Bolt (universal joint "U")-5/16"-24 threads -arm shaft to rear axle						2	2	2	2	2	2	2	
★8H 4602-A		Shaft & universal joint assy (drive)-62-3/8" long overall	1												
★8H 4602-B		Shaft & universal joint assy (drive)-52-3/4" long overall		1											
★8L 4602-A		Shaft & universal joint assy (drive)-56-1/2" long overall			1	1									
★8L 4602-B		Shaft & universal joint assy (drive)-52-3/4" long overall					1								
★1H 4602-A		Shaft & universal joint assy (drive)-62-3/16" approx. o/all length-w/o yoke (8L-4866)						1							
★1H 4602-B		Shaft & universal joint assy (drive)-58-3/16" approx. o/all length-w/o yoke (8L-4866)							1						
★1L 4602-A		Shaft & universal joint assy (drive)-56-15/32" approx. o/all length-w/o yoke (8L-4866)									1	1			
★1L 4602-B		Shaft & universal joint assy (drive) 52-7/16" approx. overall length w/o yoke (8L-4866)												1	

★ Used with but not part of Basic number 4006 assembly

† Used with HYDRA-MATIC transmission

†† Not used with HYDRA-MATIC transmission

# Lincoln and Lincoln Cosmopolitan

## CHASSIS PARTS CATALOGUE

### Rear Axle—Continued

#### REAR AXLE CHART—CONTINUED

PART NUMBER	CLASS	PART NAME	REAR AXLE																		
			++8H-4006-B	+8H-4006-C	++8L-4006-A	++8L-4006-B	+8L-4006-C	++1H-4006-B	+1H-4006-C	++1L-4006-A	++1L-4006-B	+1L-4006-C									
			NUMBER REQUIRED																		
8A 4616		Cup (rear axle driving pinion brg.)-front -2-7/8" O.D. x 7/8" wide	1	1	1	1	1	1	1	1	1	1	1	1	1	1	1	1	1	1	1
8M 4621		Cone & roller assy (rear axle driving pinion)-front	1	1	1	1	1	1	1	1	1	1	1	1	1	1	1	1	1	1	1
8L 4628		Cup (rear axle driving pinion brg.)-rear -3-3/8" O.D. x 15/16" wide	1	1	1	1	1	1	1	1	1	1	1	1	1	1	1	1	1	1	1
8L 4630		Cone & roller assy (rear axle driving pinion bearing)-rear	1	1	1	1	1	1	1	1	1	1	1	1	1	1	1	1	1	1	1
8M 4670		Slinger (driving pinion shaft oil)	1	1	1	1	1	1	1	1	1	1	1	1	1	1	1	1	1	1	1
8M 4671		Gasket (driving pinion oil seal)-Paper- 2-3/4" I.D. x 3-9/64" O.D. x .030"/.040" thick	1	1	1	1	1	1	1	1	1	1	1	1	1	1	1	1	1	1	1
8M 4672-A		Shim (driving pinion front bearing adj.)-. .003" thick	as reqd	as reqd	as reqd	as reqd	as reqd	as reqd	as reqd	as reqd	as reqd	as reqd	as reqd	as reqd	as reqd	as reqd	as reqd	as reqd	as reqd	as reqd	as reqd
8M 4672-B		Shim (driving pinion front bearing adj.)-. .005" thick	as reqd	as reqd	as reqd	as reqd	as reqd	as reqd	as reqd	as reqd	as reqd	as reqd	as reqd	as reqd	as reqd	as reqd	as reqd	as reqd	as reqd	as reqd	as reqd
8M 4672-C		Shim (driving pinion front bearing adj.)-. .010" thick	as reqd	as reqd	as reqd	as reqd	as reqd	as reqd	as reqd	as reqd	as reqd	as reqd	as reqd	as reqd	as reqd	as reqd	as reqd	as reqd	as reqd	as reqd	as reqd
8M 4672-D		Shim (driving pinion front bearing adj.)-. .030" thick	as reqd	as reqd	as reqd	as reqd	as reqd	as reqd	as reqd	as reqd	as reqd	as reqd	as reqd	as reqd	as reqd	as reqd	as reqd	as reqd	as reqd	as reqd	as reqd
8M 4673		Wick (driving pinion shaft oil seal)- 1-9/16" I.D. x 2" O.D. x 1/4" thick	1	1	1	1	1	1	1	1	1	1	1	1	1	1	1	1	1	1	1
8M 4676-A		Seal assy (rear axle driving pinion oil)- 1-3/4" I.D.-reinf. lined with leather- also coil spring around edge of leather	1	1	1	1	1	1	1	1	1	1	1	1	1	1	1	1	1	1	1
8L 4841-A		Knuckle assy (universal joint)-front	1		1	1		1		1		1	1		1		1		1		1
8L 4841-B		Knuckle assy (universal joint)-front		1				1		1				1					1		1
8L 4851-A		Flange assy (universal joint)-axle end	1	1	1	1	1														
8L 4851-B		Flange assy (universal joint)-axle end- marked with Yellow paint	1	1	1	1	1														
8C 4851		Flange assy (universal joint)-axle end							1	1	1	1	1	1	1	1	1	1	1	1	1
1L 4851-A		Flange assy (universal joint)-axle end							1	1	1	1	1	1	1	1	1	1	1	1	1
		351126-S Locknut (hex)-3/4"-16	1	1	1	1	1	1	1	1	1	1	1	1	1	1	1	1	1	1	1
		356504-S Washer (driving pinion nut)-25/32" I.D. x 1-1/2" O.D. x 1/8" thick	1	1	1	1	1	1	1	1	1	1	1	1	1	1	1	1	1	1	1
8M 4859		Deflector (driving pinion oil seal dust)	1	1	1	1	1	1	1	1	1	1	1	1	1	1	1	1	1	1	1
8L 4866		Yoke (coupling shaft flange)	1	1	1	1	1	1													
		357901-S8 Bolt (hex-hd)-3/8"-24 x 1-3/16"-drive shaft to rear axle	4	4	4	4	4	4													
		72017-8 Cotter pin-1/8" x 3/4"	4	4	4	4	4	4													
		34807-S2 Lockwasher-3/8"	4	4	4	4	4	4													
		357900-S8 Nut (hex)-3/8"-24	4	4	4	4	4	4													

+ Used with HYDRA-MATIC transmission

++ Not used with HYDRA-MATIC transmission

# Lincoln and Lincoln Cosmopolitan

## CHASSIS PARTS CATALOGUE

### Drive Shaft and Universal Joint

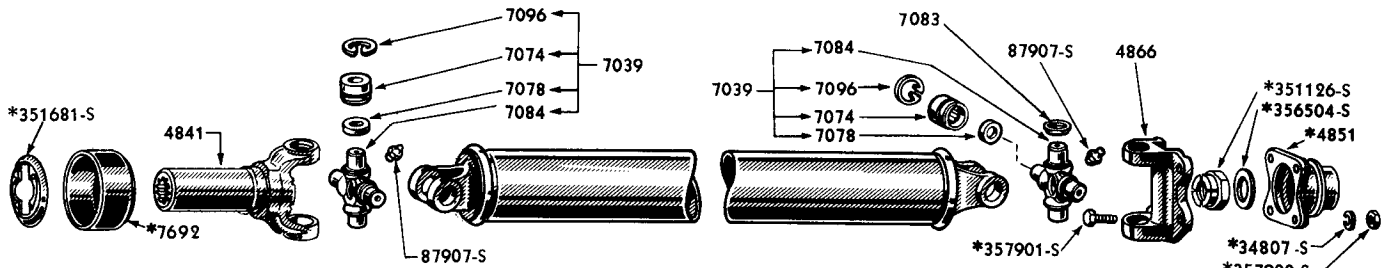

\*NOT INCLUDED IN BASIC NO. 4602 ASSEMBLY

1949-50

PL-784

### DRIVE SHAFT ASSEMBLY AND RELATED PARTS

Basic numbers only shown on illustration. Order by Part Numbers shown in list of parts.

PART NUMBER	QTY	PART NAME	NO. REQ'D	MODEL	YEAR
	++	8H-4602-A Shaft & univ. joint assy (drive)-62-3/8" overall length	1	9H	49
	+	8H-4602-B Shaft & univ. joint assy (drive)-58-15/32" overall length	1	9H,OH	49-50
	++	8L-4602-A Shaft & univ. joint assy (drive)-56-1/2" overall length	1	9L	49
	+	8L-4602-B Shaft & univ. joint assy (drive)-52-3/4" overall length	1	9L,OL	49-50
	++	1H-4602-A Shaft & universal joint assy (drive)-62-3/16" approx. o/all length-w/o yoke (8L-4866)	1	9H,OH,1H	49-51
	+	1H-4602-B Shaft & univ. joint assy (drive)-58-3/16" overall length-w/o yoke (8L-4866)	1	OH,1H	50-51
	++	1L-4602-A Shaft & universal joint assy (drive)-56-15/32" approx. o/all length-w/o yoke (8L-4866)	1	9L,OL,1L	49-51
	+	1L-4602-B Shaft & univ. joint assy (drive)-52-7/16" overall length-w/o yoke (8L-4866)	1	OL,1L	50-51
		01Y-4529 Bolt (universal joint "U")-5/16"-24 threads-drive shaft to rear axle	2	OL,OH,1L,1H	50-51
		34806-S7 Lockwasher-5/16"	4	OL,OH,1L,1H	50-51
		33798-S8 Nut (hex)-5/16"-24	4	OL,OH,1L,1H	50-51

+

Used with HYDRA-MATIC transmission

++

Not used with HYDRA-MATIC transmission

# Lincoln and Lincoln Cosmopolitan

## CHASSIS PARTS CATALOGUE

### Drive Shaft and Universal Joint—Continued

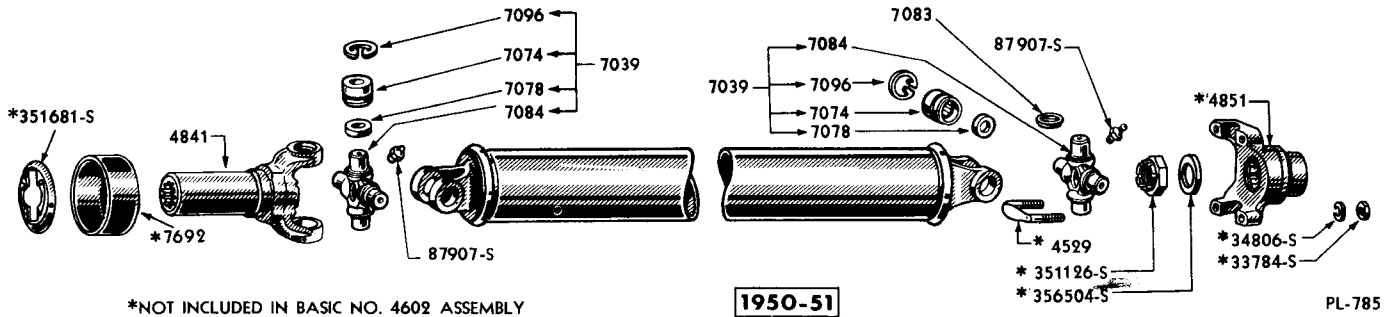

### DRIVE SHAFT ASSEMBLY AND RELATED PARTS

Basic numbers only shown on illustration. Order by Part Numbers shown in list of parts.

PART NUMBER	PART NAME	NO. REQ'D	MODEL	YEAR
01Y-7039	Kit (univ. joint)-consists of the following (4) 01Y-7074 Bearing (1) 01Y-7084 Spider (4) 01Y-7096 Snap ring	2	9L,9H,0L,0H,1L,1H	49-51
87907-S8	Fitting (lubricator)-1/4"-28 x 1/2"-for univ./jt. spider	2	9L,9H,0L,0H,1L,1H	49-51
*8L-4841-A	Knuckle assy (univ. joint)-front	1	9L,9H	49
*8L-4841-B	Knuckle assy (univ. joint)-front	1	9L,9H,0L,0H,1L,1H	49-51
*8L-7692	Shield (trans. ext. rear oil seal)	1	9L,9H,0L,0H,1L,1H	49-51
*351681-S32	Nut (spring)-2-23/32" x 2-11/16" O.D. x grip fit for 1-3/4" diameter shaft	1	9L,9H,0L,0H,1L,1H	49-51

# Frame

<b>+</b> 8H 5005-A 	NS	Frame assy-replaced by 8H-5005-C plus HAK-6054-A Kit and HAK-6028-A Kit	1	9H except 76	49
<b>+</b> 8H 5005-B 	NS	Frame assy-replaced by 8H-5005-D plus HAK-6054-A Kit and HAK-6028-A Kit	1	9H76	49
<b>+</b> 8H 5005-C 		Frame assy	1	9H,0H,1H except 76	49-51
<b>+</b> 8H 5005-D 		Frame assy	1	9H76,0H76,1H76	49-51

**+** Used with HYDRA-MATIC transmission

**+** Not used with HYDRA-MATIC transmission

# Lincoln and Lincoln Cosmopolitan

## CHASSIS PARTS CATALOGUE

### Frame—Continued

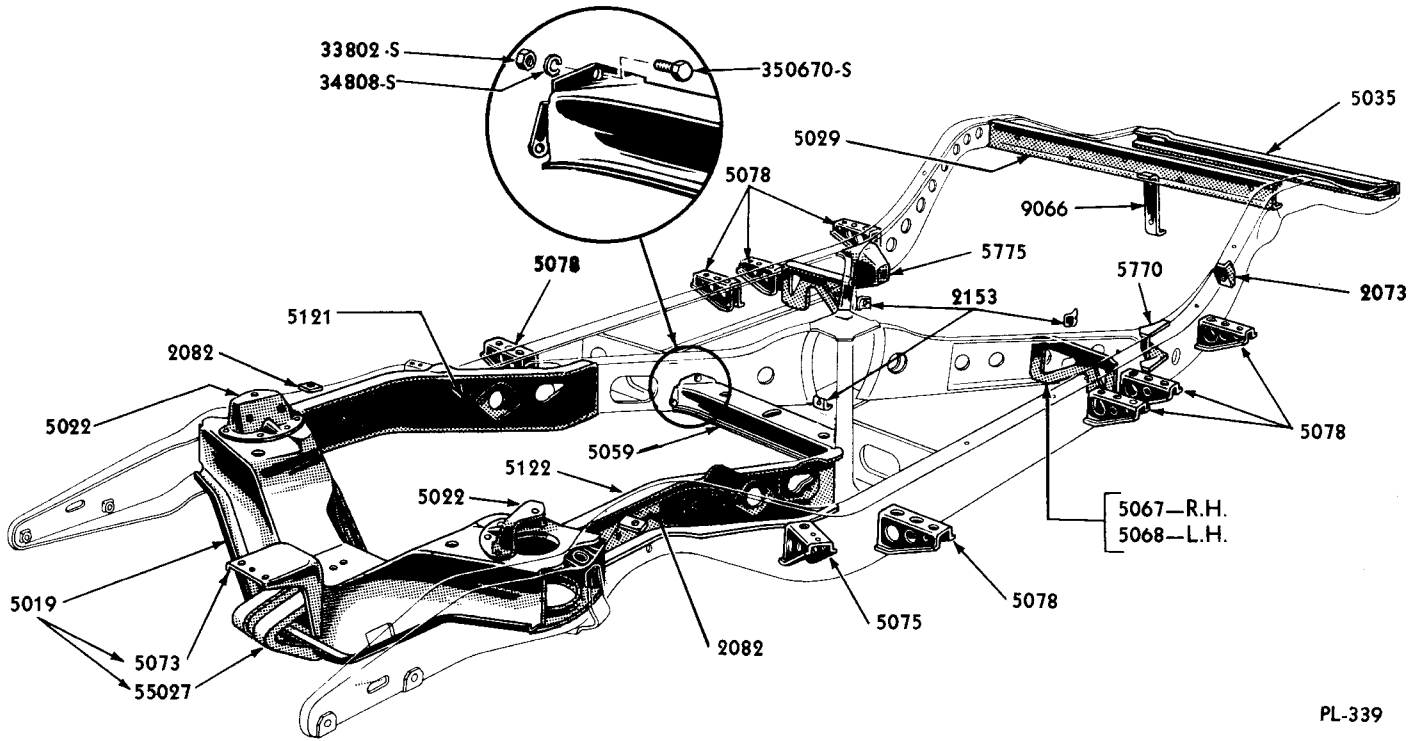

PL-339

### FRAME (8H-5005-C)

Basic numbers only shown on illustration. Order by Part Numbers shown in list of parts.

PART NUMBER	QTY	PART NAME	NO. REQ'D	MODEL	YEAR
*8L 5005-A	NS	Frame assy-not used with HYDRA-MATIC trans.- replaced by 8L-5005-D plus HAK-6054-A Kit and HAK-6028-A Kit	1	9L except 76	19 49
*8L 5005-C		Frame assy-not used with HYDRA-MATIC trans.	1	9L76	49
*8L 5005-D		Frame assy-use with HYDRA-MATIC trans.-does not include QM-2530-1	1	9L72-74, 0L, 1L	49-51
		356006-S2 Retainer nut-3/8"-24-frame rear "X" to body	2	9L, 0L, 1L	49-51

\* Does not include 8M-5078 and 8M-9066

# Lincoln and Lincoln Cosmopolitan

## CHASSIS PARTS CATALOGUE

### Frame—Continued

#### FRAME CHART

PART NUMBER	CLASS	PART NAME	FRAME							
			††8H-5005-A	††8H-5005-B	†8H-5005-C	†8H-5005-D	††8L-5005-A	††8L-5005-C	†8L-5005-D	
			NUMBER REQUIRED							
†8L 5019-A		Member assy (frame cross)-front-41/64" dia. motor support bolt holes					1	1		
8L 5019-B		Member assy (frame cross)-front-1-9/32" dia. motor support holes								1
†8H 5019-A		Member assy (frame cross)-front-41/64" dia. motor support bolt holes	1	1						
8H 5019-B		Member assy (frame cross)-front-1-9/32" dia. motor supports hole			1	1				
8M 5022-A	NS	Bracket (suspension arm and shock mounting) -upper-replaced by 8M-5022-B	2	2			2	2		
8M 5022-B		Bracket (suspension arm and shock mounting) -upper	2	2	2	2	2	2	2	2
		65044-S Rivet (rd-hd pointed)-5/16" x 15/16"-8M-5002-B to front cross member	8	8	8	8	8	8	8	8
8H 5029		Member assy (frame cross)-intermediate	1	1	1	1				
8M 5029-A		Member assy (frame cross)-intermediate- includes (1) 8M-5261					1	1	1	
1L 5034		Bracket assy (front license)			1	1				1
8H 5035		Member assy (frame cross)-rear	1	1	1	1				
8M 5035-A		Member assy (frame cross)-rear					1	1	1	
		356006-S2 Retainer nut-3/8"-24					2	2	2	
8L 5059-A		Bracket assy (engine rear support)-weld on type					1	1		
8L 5059-B		Bracket assy (engine rear support)-bolt on type								1
8H 5059-A		Bracket assy (engine rear support)-weld on type	1	1						
8H 5059-B		Bracket assy (engine rear support)-bolt on type			1	1				
		350670-S8 Bolt (hex-hd)-7/16"-20 x 7/8"-engine support bracket to frame cross member			6	6				6
		34808-S8 Lockwasher-7/16"			6	6				6
		33802-S8 Nut (hex)-7/16"-20			6	6				6

† Used with HYDRA-MATIC transmission

†† Not used with HYDRA-MATIC transmission

‡ When replacing 8L-5019-A with 8L-5019-B, 8H-5019-A with 8H-5019-B use HAK-6028-A Kit



# Lincoln and Lincoln Cosmopolitan

## CHASSIS PARTS CATALOGUE

### Frame—Continued

#### FRAME CHART—CONTINUED

PART NUMBER	CLASS	PART NAME	FRAME								
			††8H-5005-A	††8H-5005-B	†8H-5005-C	†8H-5005-D	††8L-5005-A	††8L-5005-C	†8L-5005-D		
			NUMBER REQUIRED								
8H 5067		Brace (frame side member to rear cross member)-RH	1	1	1	1					
8H 5068		Brace (frame side member to rear cross member)-LH	1	1	1	1					
8L 5073		Bracket (radiator support)-3-9/32" height from top of bracket to front cross member						1	1	1	
8H 5073		Bracket (radiator support)-2-11/16" height from top of bracket to front cross member	1	1	1	1					
8M 5075		Bracket (frame to body)-front-3-1/2" overall length						6	6	6	
8H 5075-B		Bracket (frame to body)-front-4" overall length-with offset for body mount	2	2	2	2					
8H 5078		Bracket (frame to body)-6-11/32" long	8	8	8	8					
8M 5078		Bracket (frame to body)-rear-7" long						2	2	2	
		20347-S2 Bolt (hex-hd)-5/16"-24 x 3/4"							8		
		34393-S7 Locknut (hex)-5/16"-24							8		
8L 5121-A		Bar Assy (frame "K")-RH						1	1		
8L 5121-B		Bar Assy (frame "K")-RH								1	
8H 5121-A		Bar Assy (frame "K")-RH	1	1							
8H 5121-B		Bar Assy (frame "K")-RH			1	1					
8L 5122-A		Bar Assy (frame "K")-LH						1	1		
8L 5122-B		Bar Assy (frame "K")-LH								1	
8H 5122-A		Bar Assy (frame "K")-LH	1	1							
8H 5122-B		Bar Assy (frame "K")-LH			1	1					
8L 5123		Gusset (front cross member to frame)	2	2	2	2	2	2	2	2	
		8L-5818 Plate (frame frt. cross member lower reinf.)-RH							1		
		8H-5818 Plate (frame frt. cross member lower reinf.)-RH		1							
		8L-5819 Plate (frame frt. cross member lower reinf.)-LH							1		
		8H-5819 Plate (frame frt. cross member lower reinf.)-LH		1							
		8L-5822 Plate (frame rear cross member lower reinf.)-RH							1		

† Used with HYDRA-MATIC transmission

†† Not used with HYDRA-MATIC transmission

# Lincoln and Lincoln Cosmopolitan

## CHASSIS PARTS CATALOGUE

### Frame—Continued

#### FRAME CHART—CONTINUED

PART NUMBER	CLASS	PART NAME	FRAME								
			††8H-5005-A	††8H-5005-B	††8H-5005-C	††8H-5005-D	††8L-5005-A	††8L-5005-C	††8L-5005-D		
			NUMBER REQUIRED								
	8H-5822	Plate (frame rear cross member lower reinf.)-RH		1							
	8L-5823	Plate (frame rear cross member lower reinf.)-LH						1			
	8H 5823	Plate (frame rear cross member lower reinf.)-LH		1							
	8M-55027	Guard (front cross member) -"V" shape	1	1	1	1	1	1	1	1	
	OM-55052	Retainer assy (speed grip nut)-includes 3/8"-24 square nut								8	
	60444-S	Rivet (round head)-5/16"-7/8"				as reqd					
	65041-S	Rivet (rd-hd pointed)-5/16" x 3/4"			as reqd		as reqd	as reqd	as reqd	as reqd	
	65042-S	Rivet (rd-hd pointed)-5/16" x 13/16"					as reqd	as reqd	as reqd		
	65043-S	Rivet (rd-hd pointed)-5/16" x 7/8"			as reqd		as reqd	as reqd	as reqd		
	65044-S	Rivet (rd-hd)-5/16" x 15/16"					as reqd	as reqd	as reqd		
	65071-S	Rivet (rd-hd pointed)-3/8" x 1-3/16"					as reqd	as reqd	as reqd		
	65072-S	Rivet (rd-hd pointed)-3/8" x 1-1/4"					as reqd	as reqd	as reqd		

### Battery Clamp

PART NUMBER	QUANTITY	PART NAME	NO. REQ'D	MODEL	YEAR 19__
8L-10732		Tray and support assy (battery)	1	9L,OL,1L	49-51
8H-10732		Tray and support assy (battery)	1	9H,OH,1H	49-51
24666-S7		Bolt (fl-hd)-5/16"-18 x 3/4"-support to splash pan	2	9L,9H,OL,OH,1L,1H	49-51
42789-S7		Bolt and lockwasher assy (hex head)-5/16"-18 x 3/4"-support to splash pan	4	9L,9H,OL,OH,1L,1H	49-51
OL 5162-B		Cover assy (battery box)	1	OL,OH,1L,1H	50-51
51A 5165-B		Clamp assy (battery)-with side flange open at corners	1	9L,9H	49
OL 5167-B		Lid (battery cover inspection)	1	OL,OH,1L,1H	50-51
7EH 5175		Bolt (battery clamp)-3/8"-16	2	9L,9H,OL,OH,1L,1H	49-51
		33799-S7 Nut (hex)-3/8"-16	2	9L,9H,OL,OH,1L,1H	49-51
		356409-S8 Washer (flat)-3/8"	2	9L,9H,OL,OH,1L,1H	49-51

† Used with HYDRA-MATIC transmission

†† Not used with HYDRA-MATIC transmission

# Lincoln and Lincoln Cosmopolitan

## CHASSIS PARTS CATALOGUE

### Muffler

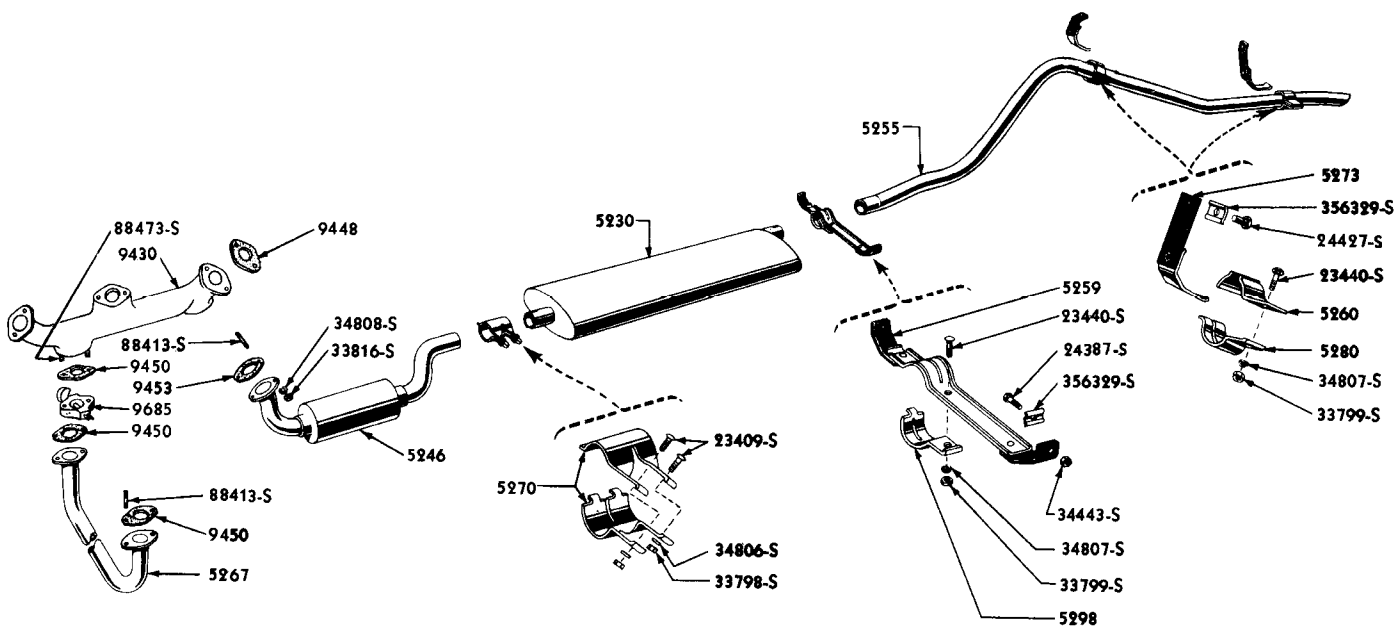

PL-804

### MUFFLER, RESONATOR AND INLET PIPE

Basic numbers only shown on illustration. Order by Part Numbers shown in list of parts.

PART NUMBER	UNITS	PART NAME	NO. REQ'D	MODEL	YEAR
8L 5230-A		Muffler assy-used on cars with resonator	1	9L,9H	1949
8L 5230-B		Muffler assy-used on cars w/o resonator	1	9L,9H,OL,OH,1L,1H	1949-51
1L 5230-A		Muffler assy-used on cars w/o resonator	1	1L,1H	1951
8EL 5246-A		Resonator & inlet pipe assy (muffler)-used on cars with resonator	1	9L	1949
8EL 5246-B		Pipe assy (muffler inlet)-used on cars w/o resonator	1	9L,OL,1L	1949-51
8EH 5246-A		Resonator & inlet pipe assy (muffler)-used on cars with resonator	1	9H	1949
8EH 5246-B		Pipe assy (muffler inlet)-use on cars w/o resonator	1	9H,OH,1H	1949-51
		34808-S2 Lockwasher-7/16"	2	9L,9H,OL,OH,1L,1H	1949-51
		33816-S Nut (hex)-7/16"-20	2	9L,9H,OL,OH,1L,1H	1949-51

# Lincoln and Lincoln Cosmopolitan

## CHASSIS PARTS CATALOGUE

PART NUMBER	PART NAME	NO. REQ'D	MODEL	YEAR
<b>Muffler—Continued</b>				
8L 5255-A	Pipe (muffler outlet)-85-3/4" long o/all	1	9L,OL,LL	49-51
8H 5255	Pipe (muffler outlet)-95-3/4" long o/all	1	9H,OH	49-50
1H 5255	Pipe (muffler outlet)-96-9/16" long o/all	1	1H	51
8L 5259	Bracket & insulator assy (muffler outlet pipe)-upper front	1	9L,9H,OL,OH,LL,1H	49-51
8M-5298	Clamp (muffler inlet pipe)-lower	1	9L,9H,OL,OH,LL,1H	49-51
23440-S8	Bolt (rd-hd)-3/8"-16 x 1-1/4" attaches muffler outlet pipe to muffler	1	9L,9H,OL,OH,LL,1H	49-51
24387-S8	Bolt (hex-hd)-5/16"-24 x 1" -attaches bracket & insulator to frame	2	9L,9H,OL,OH,LL,1H	49-51
34443-S7	Locknut (hex)-5/16"-24	2	9L,9H,OL,OH,LL,1H	49-51
34807-S2	Lockwasher-3/8"	1	9L,9H,OL,OH,LL,1H	49-51
33799-S7	Nut (hex)-3/8"-16-for attaching clamp & bracket to outlet pipe & muffler	1	9L,9H,OL,OH,LL,1H	49-51
356329-S	Washer (rectangular)-1" wide x 1-1/4" long	2	9L,9H,OL,OH,LL,1H	49-51
8L 5260-B	Clamp (muffler outlet pipe)-upper rear and intermediate-with bolt hole flanged end offset 3/16"	2	9L,9H,OL,OH,LL,1H	49-51
8L-5280	Clamp (muffler outlet pipe)-lower rear and intermediate	2	9L,9H,OL,OH,LL,1H	49-51
23440-S8	Bolt (rd-hd)-3/8"-16 x 1-1/4"	2	9L,9H,OL,OH,LL,1H	49-51
34807-S2	Lockwasher-3/8"	2	9L,9H,OL,OH	49-50
33799-S7	Nut (hex)-3/8"-16	2	9L,9H,OL,OH,LL,1H	49-51
8M 5261	Bracket assy (muffler outlet pipe)-part of 8M 5029-A	1	9L,OL,LL	49-51
8EH 5267	Pipe assy (exhaust crossover)	1	9H,OH,1H	49-51
8EL 5267	Pipe assy (exhaust crossover)	1	9L,OL,LL	49-51
34808-S8	Lockwasher-7/16"	4	9L,9H,OL,OH,LL,1H	49-51
33816-S	Nut (hex)-7/16"-20	6	9L,9H,OL,OH,LL,1H	49-51
88413-S	Stud 7/16"-20 & 7/16"-14 x 1-3/4"-LH-exhaust manifold to crossover pipe	2	9L,9H,OL,OH,LL,1H	49-51
88413-S	Stud-7/16"-20 & 7/16"-14 x 1-3/4"-exhaust manifold to inlet pipe	2	9L,9H,OL,OH,LL,1H	49-51
88473-S	Stud-7/16"-20 & 7/16"-14 x 2-1/2"-RH-exhaust manifold to crossover pipe	2	9L,9H,OL,OH,LL,1H	49-51
8L 5270	Clamp (muffler inlet pipe)	2	9L,9H,OL,OH,LL,1H	49-51
23409-S7	Bolt (hex head)-5/16"-24 x 1"-for attaching clamp	2	9L,9H,OL,OH,LL,1H	49-51
34806-S7	Lockwasher-5/16"	2	9L,9H,OL,OH,LL,1H	49-51
33798-S8	Nut (hex)-5/16"-24	2	9L,9H,OL,OH,LL,1H	49-51

# Lincoln and Lincoln Cosmopolitan

## CHASSIS PARTS CATALOGUE

PART NUMBER	U.S. & F.C.	PART NAME	NO. REQ'D	MODEL	YEAR 19 _____
-------------	-------------	-----------	-----------	-------	------------------

### Muffler—Continued

8M 5273-A		Bracket & insulator assy (muffler outlet pipe)- intermediate and rear	2	9L,9H,OL,OH,1L,1H	49-51
	23440-S8	Bolt (rd-hd)-3/8"-16 x 1-1/4"	2	9L,9H,OL,OH,1L,1H	49-51
	24367-S7	Bolt (hex hd)-5/16"-24 x 7/8"- outlet pipe bracket and insulator assy to frame	2	9L,9H,OL,OH,1L,1H	49-51
	34807-S2	Lockwasher-3/8"	2	9L,9H,OL,OH,1L,1H	49-51
	33799-S7	Nut (hex)-3/8"-16	2	9L,9H,OL,OH,1L,1H	49-51
	356329-S	Washer (rectangular)-1" wide x 1-1/4" long	2	9L,9H,OL,OH,1L,1H	49-51
8L 5280		Clamp (muffler outlet pipe)-lower rear and intermediate	2	9L,9H,OL,OH,1L,1H	49-51
	8L-5260-A	Clamp (muffler outlet pipe)-upper rear and intermediate	2	9L,9H	49
	8L-5260-B	Clamp (muffler outlet pipe)-upper rear and intermediate-with bolt hole flanged end offset 3/16"	2	9L,9H,OL,OH,1L,1H	49-51
	23440-S8	Bolt (rd-hd)-3/8"-16 x 1-1/4"	2	9L,9H,OL,OH,1L,1H	49-51
	34807-S2	Lockwasher-3/8"	2	9L,9H,OL,OH,1L,1H	49-51
	33799-S7	Nut (hex)-3/8"-16	2	9L,9H,OL,OH,1L,1H	49-51
8M 5298		Clamp (muffler inlet pipe)-lower-used with 8L-5259	1	9L,9H,OL,OH,1L,1H	49-51

## Front Spring

8L 5310-A		Spring (front)-identification markings-Red paint spots	2	9L,9H,0L,1L	49-51
8L 5310-B		Spring (front)-heavy duty-spec. equipment-identification markings-Blue paint spots	2	9L,9H,0L,0H,1L	49-51
8H 5310-B		Spring (front)-identification markings-White paint spots	2	9H,0H	49-50
0H 5310-A		Spring (front)-identification markings-Orange paint spots	2	0H76	50
1H 5310-A		Spring (front)-identification markings-Gray paint spots	2	1H72-74	51
1H 5310-B		Spring (front)-heavy duty-special equipment-identification markings-Brown paint spots	2	1L,1H	51
1H 5310-C		Spring (front)-identification markings-Orange paint spots	2	1H76	51
1H 5310-D	NS	Spring (front)-heavy duty-special equipment-identification markings-Purple paint spots-replaced by 1H-5310-B	2	1H76	51
8A 5333		Nut (rear spring clip)-1/2"-20	8	9L,9H,0L,0H,1L,1H	49-51
OM 5334		Liner (rear spring clamp)-Rubber-cut to length-used with OM-5724-A, B, C, D or E, 1M-5724-A clamps	as reqd	9L,9H,0L,0H,1L,1H	49-51
OM 5355		Shim (front spring)	as reqd	9L,9H,0L,0H,1L,1H	49-51
OM 5363		Retainer (front spring shim)	as reqd	9L,9H,0L,0H	49-50
8M 5414-A		Insulator (front suspension coil spring)-lower	2	9L,9H,0L,0H,1L,1H	49-51
8M 5415-A		Insulator (front suspension coil spring)-upper	2	9L,9H,0L,0H,1L,1H	49-51

# Lincoln and Lincoln Cosmopolitan

## CHASSIS PARTS CATALOGUE

### Front Stabilator

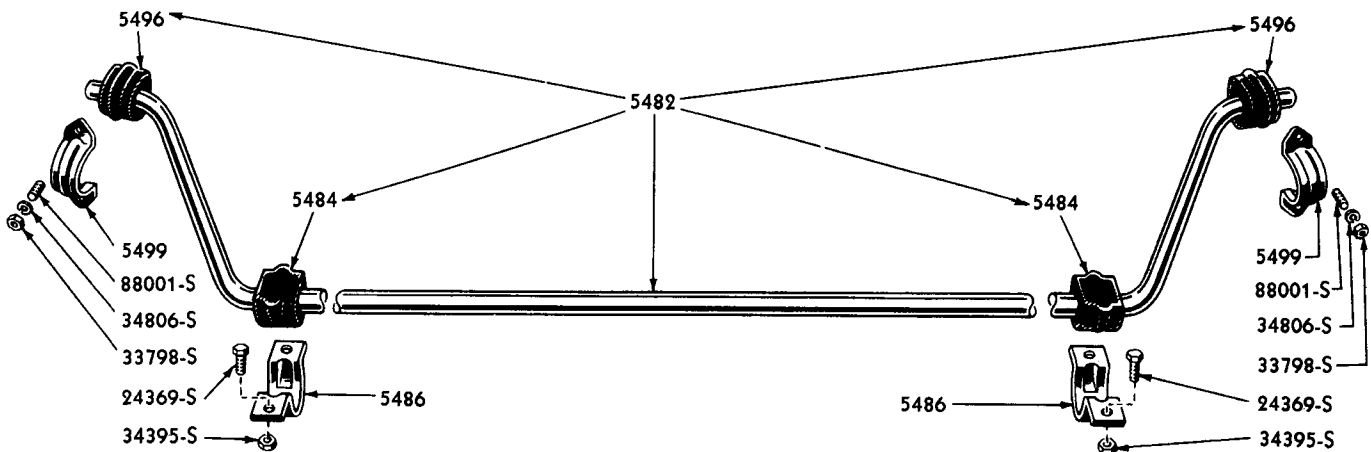

PL-156

### FRONT STABILATOR

Basic numbers only shown on illustration. Order by Part Numbers shown in list of parts.

PART NUMBER	QUANTITY	PART NAME	NO. REQ'D	MODEL	YEAR 19
8L 5482		Stabilator assy-consists of (2) 8M-5484, (1) 8L-5494, (2) 8L-5496	1	9L,9H,OL,OH,1L,1H	49-51
8L 5484		Insulator (stabilator bar to frame)-Rubber	2	9L,9H,OL,OH,1L,1H	49-51
8M 5486		Bracket (stabilator to frame)	2	9L,9H,OL,OH,1L,1H	49-51
		24369-S8 Bolt (hex-hd)-3/8"-24 x 7/8"-stabilator bracket to frame	4	9L,9H,OL,OH,1L,1H	49-51
		34395-S7 Locknut (hex)-3/8"-24	4	9L,9H,OL,OH,1L,1H	49-51
8L 5494	NS	Bar (stabilator)-order 8L-5482	1	9L,9H,OL,OH,1L,1H	49-51
8M 5496		Bushing (stabilator to spindle support)-Rubber	2	9L,9H,OL,OH,1L,1H	49-51
8M 5499		Bracket (stabilator to spindle support)	2	9L,9H,OL,OH,1L,1H	49-51
		34806-S7 Lockwasher-5/16"	4	9L,9H,OL,OH,1L,1H	49-51
		33798-S8 Nut (hex)-5/16"-24	4	9L,9H,OL,OH,1L,1H	49-51
		88001-S8 Stud-5/16"-18 and 5/16"-24 x 7/8"-stabilator bracket to spindle support	4	9L,9H,OL,OH	49-50
		88351-S8 Stud-5/16"-18 and 5/16"-24 x 7/8"-stabilator bracket to spindle support	4	9L,9H,OL,OH,1L,1H	49-51

# Lincoln and Lincoln Cosmopolitan

## CHASSIS PARTS CATALOGUE

### Rear Springs, Hangers and Clips

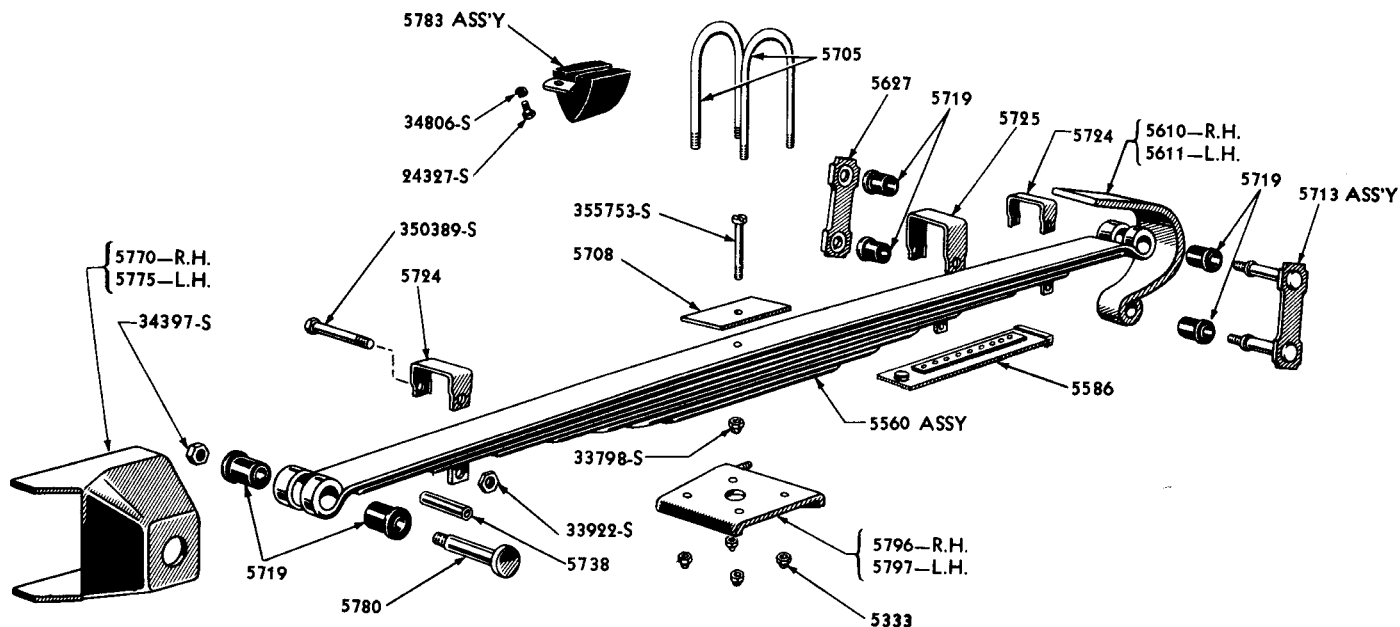

PL-803

### REAR SPRINGS, HANGERS AND CLIPS

Basic numbers only shown on illustration. Order by Part Numbers shown in list of parts.

PART NUMBER	QTY	PART NAME	NO. REQ'D	MODEL	YEAR
		8L-19580-A Grease (spring lubrication)-5 lb.	as reqd	9L, 0L, 9H, 0H, 1L, 1H	49-51
		8L-19580-B Grease (spring lubrication)-quart	as reqd	9L, 0L, 9H, 0H, 1L, 1H	49-51
*8H 5560-A		Spring assy (rear)-standard-8 leaf-1100 pound load	2	9H	49
*8H 5560-B		Spring assy (rear)-heavy duty-9 leaf-1100 pound load	2	9H, 0H, 1H	49-51
*0H 5560-A		Spring assy (rear)-standard-8 leaf-1050 pound load	2	9H, 0H, 1H	49-51
*0H 5560-B	NS	Spring assy (rear)-heavy duty-replaced by 8H-5560-B	2	0H	50
		351656-S2 Bolt (special head spring center)-5/16"-24 x 3-1/4"	2	9H, 0H, 1H	49-51
		355789-S Bolt (special head)-5/16"-24 x 2-7/8"	2	9H, 0H, 1H	49-51
		350389-S2 Bolt (special head)-5/16"-18 x 2-7/16"	6	9H, 0H, 1H	49-51
		356700-S Bolt (special head)-center-5/16"-24 x 3-3/4"	2	9H, 0H, 1H	49-51
		33798-S8 Nut (hex)-5/16"-24	2	9H, 0H, 1H	49-51
		33922-S2 Nut (hex check)-5/16"-18	6	9H, 0H, 1H	49-51

\* Part number stamped on under side of bottom leaf



# Lincoln and Lincoln Cosmopolitan

## CHASSIS PARTS CATALOGUE

PART NUMBER	PART NAME	NO. REQ'D	MODEL	YEAR
<b>Rear Springs, Hangers and Clips - Continued</b>				
*8L 5560-A	Spring assy (rear)-standard-8 leaf-940 pound load	2	9L74-76, 0L74, 1L74	49-51
*8L 5560-B	Spring assy (rear)-heavy duty-9 leaf-940 pound load	2	9L74-76, 0L74, 1L74	49-51
*8L 5560-C	Spring assy (rear)-standard-8 leaf-800 pound load	2	9L76	49
*8M 5560-A	Spring assy (rear)-standard-8 leaf-880 pound load	2	9L72, 0L72, 1L72	49-51
*8M 5560-D	Spring assy (rear)-heavy duty-9 leaf- 880 pound load	2	9L72, 0L72, 1L72	49-51
*8L 5560-A	Spring assy (rear)-standard-8 leaf-940 pound load- used on approximately 250 cars	2	9L72	49
	355753-S Bolt (special head)-5/16"-24 x 2-3/4"	2	9L, 0L, 1L	49-51
	351656-S2 Bolt (special head spring center)-5/16"-24 x 3-1/4"	2	9L, 0L, 1L	49-51
	350389-S2 Bolt (special head spring clamps)-5/16"-18 x 2-7/16"	6	9L, 0L, 1L	49-51
	33798-S8 Nut (hex)-5/16"-24	2	9L, 0L, 1L	49-51
	33922-S2 Nut (hex check)-5/16"-18	6	9L, 0L, 1L	49-51
LAK 5560-A	Kit (rear spring service leaf)-consists of the following (2) 0M-5565 Leaf (2) 33798-S8 Nut (2) 355753-S Bolt	1	9L, 0L	49-50
8M 5586	Insert assy (rear spring)-packaged 8 pieces to carton-amount necessary for one rear spring	16	9L, 9H, 0L, 0H, 1L, 1H	49-51
8H 5610	Hanger (rear spring shackle)-rear-RH	1	9H	49
0H 5610	Hanger (rear spring shackle)-rear-RH	1	0H, 1H	50-51
8M 5610	Hanger (rear spring shackle)-rear-RH	1	9L	49
0M 5610	Hanger (rear spring shackle)-rear-RH	1	0L, 1L	50-51
8H 5611	Hanger (rear spring shackle)-rear-LH	1	9H	49
0H 5611	Hanger (rear spring shackle)-rear-LH	1	0H, 1H	50-51
8M 5611	Hanger (rear spring shackle)-rear-LH	1	9L	49
0M 5611	Hanger (rear spring shackle)-rear-LH	1	0L, 1L	50-51
	350018-S2 Bolt (hex-hd)-3/8"-24 x 1"	2	9L, 0L, 1L	49-51
	34807-S2 Lockwasher-3/8"	2	9L, 0L, 1L	49-51
	34445-S7 Nut (hex)-3/8"-24	2	9L, 0L, 1L	49-51
	65071-S Rivet (rd-hd pointed)-3/8" x x 1-3/16"	as reqd	9L, 0L, 1L	49-51
8M 5627-A	NS Bar (rear spring shackle)-outer-ends cut out at corners-replaced by 8M-5630-A	2	9L, 9H	49
8M 5627-B	Bar (rear spring shackle)-outer	2	9L, 9H	49
0M 5627	Bar (rear spring shackle)-outer	2	0L, 0H, 1L, 1H	50-51
	34397-S8 Locknut (hex)-7/16"-20	6	9L, 9H, 0L, 0H, 1L, 1H	49-51
8M 5630-A	Kit (rear spring rear shackle and front bolt)- consists of the following (1) 8M-5627-A Bar (1) 8M-5713-A Studs & shackle (6) 8M-5719 Bushing (1) 8M-5780-A Pin (3) 34397-S8 Locknut	2	9L, 9H	49
0M 5630	Kit (rear spring rear shackle and front bolt)- consists of the following (1) 0M-5627 Bar (1) 0M-5713 Studs & shackle (6) 8M-5719 Bushing (1) 8M-5780-A Pin (3) 34397-S8 Locknut	2	0L, 0H, 1L, 1H	50-51

\* Part number stamped on under side of bottom leaf

# Lincoln and Lincoln Cosmopolitan

## CHASSIS PARTS CATALOGUE

### Rear Springs, Hangers and Clips—Continued

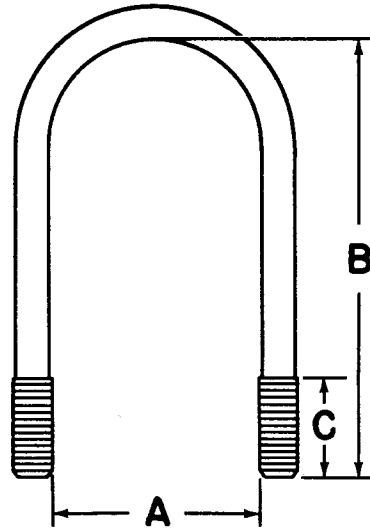

PL-923

#### REAR SPRING CLIP CHART

PART NUMBER	CLASS.	A	B	C	THREAD SIZE	NO. REQ'D	MODEL	YEAR 19__
8L 5705-A		2-49/64"	7-1/4"	1-1/4"	1/2"-20	4	9L72-74-76,9H	49
●8L 5705-B	NS	2-49/64"	7-51/64"	1-1/4"	1/2"-20	4	9L72-74-76,9H	49
●8L 5705-D	NS	2-49/64"	7-13/16"	1-1/4"	1/2"-20	4	9L72-74-76,9H	49
★8L 5705-E		2-49/64"	7-1/4"	1-1/4"	1/2"-20	4	9L,9H,0L,0H,1L,1H	49-51
★8L 5705-F		2-49/64"	7-51/64"	1-1/4"	1/2"-20	4	9L,9H,0L,0H,1L,1H	49-51
8L 5705-G		2-49/64"	8-1/4"	2-1/2"	1/2"-20	4	9L,9H,0L,0H,1L,1H	49-51
8M 5705-B		2-1/2"	7-45/64"	1-1/4"	1/2"-20	4	9L72	49
★8M 5705-H		2-1/2"	7-25/32"	1-1/4"	1/2"-20	4	9L72,0L72	49-50

PART NUMBER	CLASS.	PART NAME	NO. REQ'D	MODEL	YEAR 19__
8A 5703		Spacer (spring clamp)-11/32" O.D. x 1" long-slotted-used with OM-5724 and 1M-5724	as reqd.	1L,1H	51
		8A-5333 Nut (rear spring clip)-1/2"-20	8	9L,9H,0L,0H,1L,1H	49-51
8M 5708		Plate (rear spring center bolt)	2	9L,9H,0L,0H,1L,1H	49-51
8M 5713-A	NS	Studs & shackle assy (rear spring)-replaced by 8M-5630-A	2	9L,9H	49
OM 5713-A	NS	Studs & shackle assy (rear spring)-replaced by OM-5630	2	0L,0H	50
		34397-S2 Locknut (hex)-7/16"-20	4	9L,9H,0L,0H,1L,1H	49-51
8M 5719		Bushing (rear spring shackle)	12	9L,9H,0L,0H,1L,1H	49-51

● Replaced by 8L-5705-F

★ With flat at closed end, inner side

# Lincoln and Lincoln Cosmopolitan

## CHASSIS PARTS CATALOGUE

### Rear Springs, Hangers and Clips – Continued

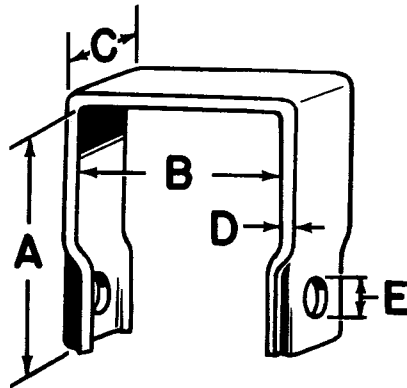

PL-222

REAR SPRING OUTER CLAMP CHART

PART NUMBER	CLAS	A	B	C	D	E	NO. REQ'D	MODEL	YEAR 19__
8H 5724		2.100"	2.110"	1.00"	.090"	.340"	4	9L, 9H, 0L, 0H, 1L, 1H	49-51
†8M 5724-A	NS	1.880"	2.110"	1.00"	.090"	.340"	4	9L74-76	49
8M 5724-B		1.940"	2.110"	1.00"	.090"	.340"	4	9L, 0L, 1L	49-51
●8M 5724-A		1-1/8"	2-3/16"	5/8"	3/32"	9/32"	as req'd	9L, 0L, 1L	49-51
●8M 5724-B		1-3/16"	2-3/16"	5/8"	3/32"	9/32"	as req'd	9L74-76, 9H, 0L74, 0H, 1L74	49-51
●8M 5724-C		1-13/16"	2-3/16"	5/8"	3/32"	9/32"	as req'd	9L74-76, 0L74, 1L74	49-51
●8M 5724-D		1-15/16"	2-3/16"	5/8"	3/32"	9/32"	as req'd	9L74-76, 9H, 0L74, 0H, 1L72-74, 1H	49-51
●8M 5724-E		2-5/16"	2-3/16"	5/8"	3/32"	9/32"	as req'd	9H, 0H, 1H	49-51
●1M 5724-A		1-5/8"	2-3/16"	5/8"	3/32"	9/32"	as req'd	1L, 1H	51

PART NUMBER	CLAS	PART NAME	NO. REQ'D	MODEL	YEAR 19__
OM-5334		Liner (rear spring clamp)-Rubber-cut to length-used with OM-5724-A -B-C-D-E & 1M-5724-A clamps	as	9L, 9H, 0L, 0H, 1L, 1H	49-51
21481-S2		Bolt (hex-hd)-1/4"-20 x 1-3/4" -for OM-5724-A, B, C, D & E; 1M-5724-A to rear spring	4	9L, 9H, 0L, 0H	49-50
33795-S7		Nut (hex)-1/4"-20-used with 21481-S2	4	9L, 9H, 0L, 0H	49-50
34805-S8		Lockwasher-1/4"	4	9L, 9H, 0L, 0H, 1L, 1H	49-51

† Replaced by 8M-5724-B

● Used as replacements on springs originally equipped with strap type clip

# Lincoln and Lincoln Cosmopolitan

## CHASSIS PARTS CATALOGUE

### Rear Springs, Hangers and Clips – Continued

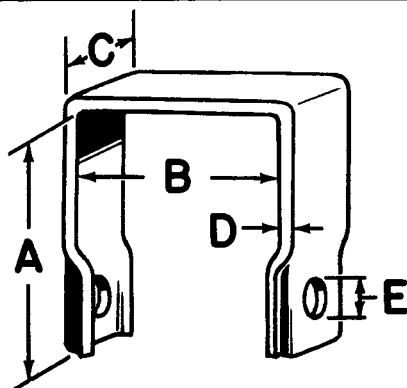

PL-222

#### REAR SPRING INNER CLAMP CHART

PART NUMBER	UNDF.C.	A	B	C	D	E	NO. REQ'D	MODEL	YEAR 19__
8M 5725-A		2.790"	2.110"	1.00"	.090"	.340"	2	9L,OL,1L	49-51
**8M 5725-B	NS	2.570"	2.110"	1.00"	.090"	.340"	2	9L,9H	49
††8M 5725-C	NS	3.060"	2.110"	1.00"	.090"	.340"	2	9L	49
8E 5725-A		2.790"	2.110"	1.00"	.090"	.340"	2	9H,OH,1H	49-51
8H 5725-B		3.150"	2.110"	1.00"	.090"	.340"	2	9L,9H,OL,OH,1L,1H	49-51

PART NUMBER	UNDF.C.	PART NAME	NO. REQ'D	MODEL	YEAR 19__
		350389-S2 Bolt (hex head)-5/16"-18 x 2-7/16"-for spring clamp	6	9L,9H,OL,OH,1L,1H	49-51
		33922-S2 Nut (hex)-5/16"-18	6	9L,9H,OL,OH,1L,1H	49-51
8M 5738		Spacer (rear spring clip clamp)-21/64" I.D. x 13/32" O.D. x 1-3/4" long	6	9L,9H,OL,OH,1L,1H	49-51
8M 5770		Hanger assy (rear spring)-front-RH	1	9L,OL,1L	49-51
8H 5770		Hanger (rear spring)-front-RH	1	9H,OH,1H	49-51
8M 5775		Hanger assy (rear spring)-front-LH	1	9L,OL,1L	49-51
8H 5775		Hanger (rear spring)-front-LH	1	9H,OH,1H	49-51
8M 5780-A	NS	Pin assy (rear spring)-front-replaced by 8M-5630-A or 8M-5630	2	9L,9H,OL,OH	49-50
8M 5783-A		Bumper assy (rear axle)-2-1/4" long-use in pairs-conical	2	9L,9H	49
8M 5783-A		Bumper assy (floor pan)-conical	1	9H	49
8M 5783-C		Bumper assy (rear axle)-oblong tapered-use in pairs	2	9L,9H,OL,OH,1L,1H	49-51
8M 5783-C		Bumper assy (floor pan)-oblong tapered	1	9L,9H,OL,OH,1L,1H	49-51
		24327-S2 Bolt (hex head)-5/16"-24 x 5/8"-bumper to frame	4	9L,9H,OL,OH	49-50
		24327-S2 Bolt (hex head)-5/16"-24 x 5/8"-bumper to floor pan	2	9L,9H,OL,OH,1L,1H	49-51
		34806-S7 Lockwasher-5/16"	6	9L,9H,OL,OH,1L,1H	49-51
		40156-S8 Screw (hex-hd)-5/16"-18 x 5/8"-bumper to frame	4	1L,1H	51

\*\* Replaced by 8M-5725-A

†† Replaced by 8H-5725-B

# Lincoln and Lincoln Cosmopolitan

## CHASSIS PARTS CATALOGUE

### Rear Springs, Hangers and Clips – Continued

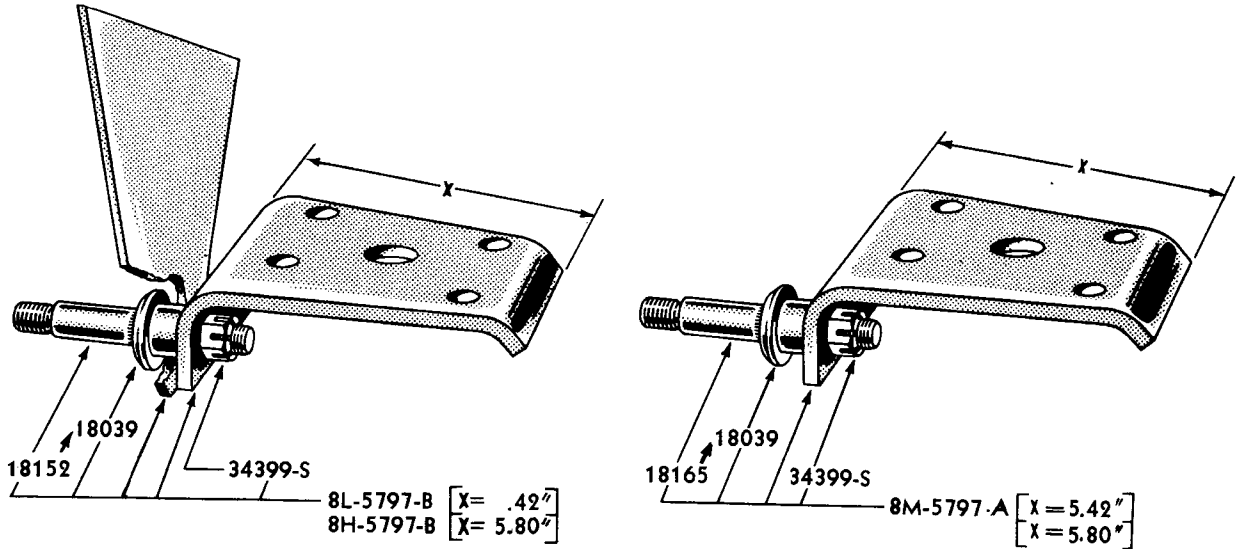

PL-811

### REAR SPRING CLIP PLATES

Basic numbers only shown on illustration. Order by Part Numbers shown in list of parts.

PART NUMBER	CLASS	PART NAME	NO. REQ'D	MODEL	YEAR
8L 5796-A		Plate assy (rear spring clip)-RH-includes 8M-18165-A Stud-use with Standard Spring	1	9L	49
8L 5796-B		Plate, stone guard & stud assy (rear spring clip)-RH-includes 8M-18165-B Stud-use with heavy duty spring	1	9L,OL,1L	49-51
8L 5796-C		Plate assy (rear spring clip)-RH-includes 8M-18152 Stud-use with Standard Spring	1	9L,OL,1L,1H	49-51
8H 5796-A		Plate assy (rear spring clip)-RH-includes 8M-18165-A Stud-use with Standard Spring	1	9H	49
8H 5796-B		Plate, stone guard & stud assy (rear spring clip)-RH-includes 8M-18165-B Stud-use with H/D springs	1	9H,OH,1H	49-51
8H 5796-C		Plate assy (rear spring clip)-RH-includes 8M-18152 Stud-use with Standard Spring	1	9H,OH,1H	49-51
8L 5797-A		Plate assy (rear spring clip)-LH-includes 8M-18165-A Stud-use with Standard Spring	1	9L	49
8L 5797-B		Plate, stone guard & stud assy (rear spring clip)-LH-includes 8M-18165-B Stud-use with H/D springs	1	9L,OL,1L	49-51
8L 5797-C		Plate assy (rear spring clip)-LH-includes 8M-18152 Stud-use with Standard Spring	1	9L,OL,1L	49-51
8H 5797-A		Plate assy (rear spring clip)-LH-includes 8M-18165-A Stud-use with Standard Spring	1	9H	49
8H 5797-B		Plate, stone guard & stud assy (rear spring clip)-LH-includes 8M-18165-B Stud-use with H/D springs	1	9H,OH,1H	49-51
8H 5797-C		Plate assy (rear spring clip)-LH-includes 8M-18152 Stud-use with Standard Spring	1	9H,OH,1H	49-51
		8M-18165-A Stud & washer assy (rear shock absorber)-upper & lower-use with std. springs-see chart on page 300	4	9L,9H,OL,OH	49-50

# Lincoln and Lincoln Cosmopolitan

## CHASSIS PARTS CATALOGUE

PART NUMBER	CLASS	PART NAME	NO. REQ'D	MODEL	YEAR 19 _____
<b>Rear Springs, Hangers and Clips – Continued</b>					
		8M-18165-B Stud & washer assy (rear shock absorber)-lower-use with H/D springs-see chart on page 300	2	9L,9H,0L,0H	49-50
		8M-18152 Stud assy (rear shock absorber)-upper-used with H/D springs-also lower with 8L-5796-7-C, 8H-5796-7-C-see chart on page 300	2	9L,9H,0L,0H,1L,1H	49-51
		34399-S2 Locknut (hex)-1/2"-20-stud to plate	2	9L,9H,0L,0H,1L,1H	49-51
8L 5818		Plate (frame front cross member lower reinf.)-RH	1	9L76	49
8H 5818		Plate (frame front cross member lower reinf.)-RH	1	9H76	49
8L 5819		Plate (frame front cross member lower reinf.)-LH	1	9L76	49
8H 5819		Plate (frame front cross member lower reinf.)-LH	1	9H76	49
8L 5822		Plate (frame rear cross member lower reinf.)-RH	1	9L76	49
8H 5822		Plate (frame rear cross member lower reinf.)-RH	1	9H76	49
8L 5823		Plate (frame rear cross member lower reinf.)-LH	1	9L76	49
8H 5823		Plate (frame rear cross member lower reinf.)-LH	1	9H76	49

# Lincoln and Lincoln Cosmopolitan

## CHASSIS PARTS CATALOGUE

PART NUMBER	PART NAME	NO. REQ'D	MODEL	YEAR
<b>Rear Springs, Hangers and Clips – Continued</b>				
	8M-18165-B Stud & washer assy (rear shock absorber)-lower-use with H/D springs-see chart on page 300	2	9L,9H,OL,OH	49-50
	8M-18152 Stud assy (rear shock absorber)-upper-used with H/D springs-also lower with 8L-5796-7-C, 8H-5796-7-C-see chart on page 300	2	9L,9H,OL,OH,1L,1H	49-51
	34399-82 Locknut (hex)-1/2"-20-stud to plate	2	9L,9H,OL,OH,1L,1H	49-51
8L 5818	Plate (frame front cross member lower reinf.)-RH	1	9L76	49
8H 5818	Plate (frame front cross member lower reinf.)-RH	1	9H76	49
8L 5819	Plate (frame front cross member lower reinf.)-LH	1	9L76	49
8H 5819	Plate (frame front cross member lower reinf.)-LH	1	9H76	49
8L 5822	Plate (frame rear cross member lower reinf.)-RH	1	9L76	49
8H 5822	Plate (frame rear cross member lower reinf.)-RH	1	9H76	49
8L 5823	Plate (frame rear cross member lower reinf.)-LH	1	9L76	49
8H 5823	Plate (frame rear cross member lower reinf.)-LH	1	9H76	49

## Cylinder and Engine Supports

8EL 6008	Kit (engine overhaul gasket)-consists of the following (1) 8EL-6020 Gasket (2) 8EL-6051-D Gasket (1) 8EL-6344-B Gasket (1) 8EL-6521 Gasket (1) 8EL-6626 Gasket (2) 8EL-6643 Seal (1) 8EL-6659 Gasket (1) 8EL-6669 Gasket (1) 8EL-6698 Gasket (1) 8EL-6700 Packing (2) 8EL-6701-B Packing (1) 8EL-6707 Packing (2) 8EL-6710 Gasket (1) B-6734 Gasket (2) 8EL-8255-C Gasket (1) 8EL-8507-B Gasket (1) 8EL-8508-B Gasket (1) 8EL-9374 Gasket (1) 7RA-9417 Gasket (6) 7EH-9448-A Gasket (3) 8EL-9450 Gasket (1) 8EL-9453 Gasket (1) 7EH-9603 Spacer (1) 8EL-9654 Gasket	1	9L,9H,OL,OH,1L,1H	49-51
++LEL 6009-A	Cylinder assy-with rotatable valves	1	9L,9H,OL,OH,1L,1H	49-51
+LEL 6009-B	Cylinder assy-with rotatable valves-includes 8EL-6394-B	1	9L,9H,OL,OH,1L,1H	49-51
+LEL 6009-C	Cylinder assy-with rotatable valves-includes 1EL-6394-A	1	1L,1H	51
+8EL 6010-B	Block assy (cylinder)-includes 8EL-6394-B	1	9L,9H,OL,OH	49-50
++8EL 6010-C	Block assy (cylinder)-with undercut between cyl. bores & intake ports-when replacing 8EL-6010-A also use (8) OEL-6110-A and (1) OEL-6149-A	1	9L,9H,OL,OH,1L,1H	49-51
+8EL 6010-D	Block assy (cylinder)-with undercut between cyl. bores & intake ports-includes 8EL-6394-B-when replacing 8EL-6010-B also use (8) OEL-6110-A and (1) OEL-6149-A	1	9L,9H,OL,OH,1L,1H	49-51
+LEL 6010-A	Block assy (cylinder)	1	1L,1H	51
	++HAK-66010-A Cylinder block with fitted pistons-consists of the following (1) 8EL-6010-C Cylinder block (8) OEL-6110-A Pistons	1	9L,9H,OL,OH,1L,1H	49-51
	++HAK-66010-B Cylinder block with fitted pistons-consists of the following (1) 8EL-6010-D Cylinder block (8) OEL-6110-A Pistons	1	9L,9H,OL,OH,1L,1H	49-51

++ Not used with HYDRA-MATIC transmission

+ Used with HYDRA-MATIC transmission

# Lincoln and Lincoln Cosmopolitan

## CHASSIS PARTS CATALOGUE

### Cylinder and Engine Supports—Continued

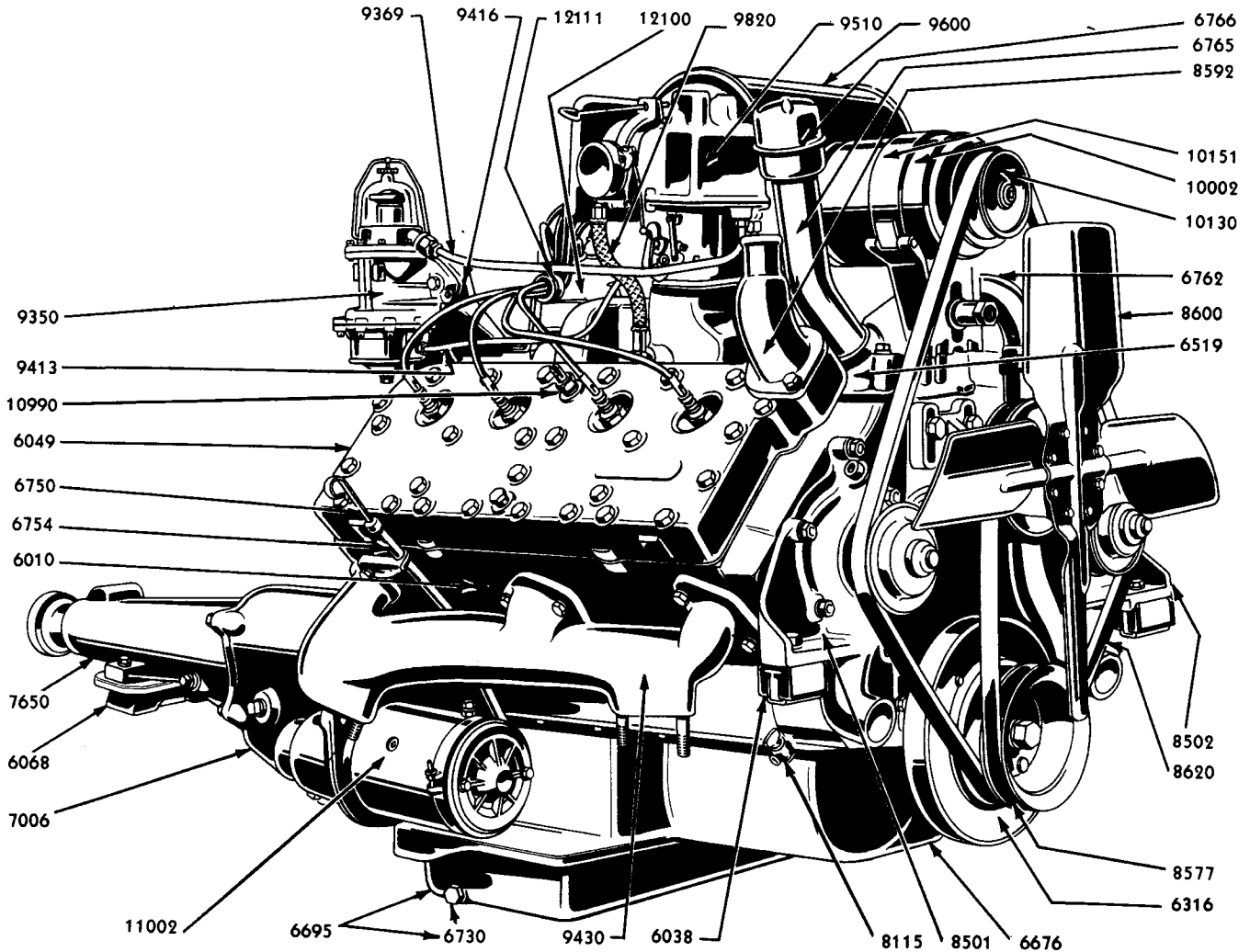

RIGHT FRONT VIEW

ENGINE (WITH TRANSMISSION)

PL-210

Basic numbers only shown on illustration. Order by Part Numbers shown in list of parts.

PART NUMBER	QTY	PART NAME	NO. REQ'D	MODEL	YEAR 19__
73259-S		Dowel pin-3/8" x 1/2"-front cover to cylinder block	2	9L,9H,OL,OH,1L,1H	49-51
18-6026-A		Plug (tapered thread)-1/4"-18-tappet oil line	2	9L,9H,OL,OH,1L,1H	49-51
7HA-6026-A		Plug (tapered thread)-3/8"-18-cylinder block main oil line	1	9L,9H,OL,OH,1L,1H	49-51
8EL-6026		Plug (tapered thread)-3/8"-18-cylinder block oil line-rear-use when hole in block is threaded	1	9L,9H,OL,OH,1L,1H	49-51



# Lincoln and Lincoln Cosmopolitan

## CHASSIS PARTS CATALOGUE

### Cylinder and Engine Supports—Continued

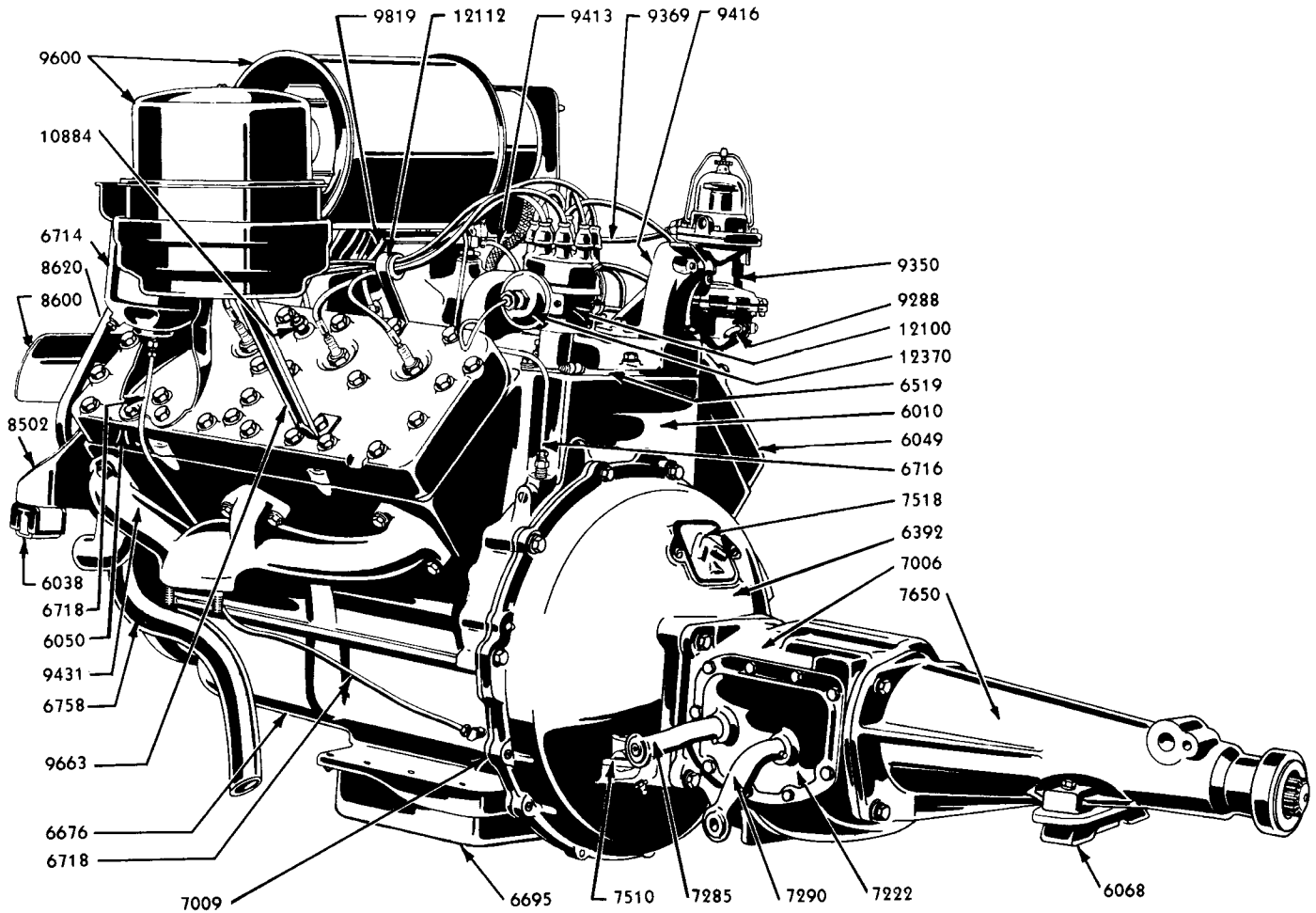

LEFT REAR VIEW

PL-191

### ENGINE (WITH TRANSMISSION)

Basic numbers only shown on illustration. Order by Part Numbers shown in list of parts.

PART NUMBER	QUANTITY	PART NAME	NO. REQ'D	MODEL	YEAR
358132-S		Plug (expansion)-35/64"-cyl. block oil line-rear-use when hole in block is not threaded	1	9L,9H,OL,OH,1L,1H	49-51
358066-S8		Plug (tapered thread)-3/8"-cyl. block oil line	1	9L,9H,OL,OH,1L,1H	49-51
358097-S		Plug (expansion)-1-3/8"	2	9L,9H,OL,OH,1L,1H	49-51
358099-S		Plug (expansion)-1-3/4"	2	9L,9H,OL,OH,1L,1H	49-51
358132-S		Plug (expansion)-35/64"-cyl. block oil line-rear-use when hole in block is not threaded	1	9L,9H,OL,OH,1L,1H	49-51
†353055-S7		Plug (pipe)-1/4"-18	1	9L,9H,OL,OH,1L,1H	49-51

† Used with HYDRA-MATIC transmission

# Lincoln and Lincoln Cosmopolitan

## CHASSIS PARTS CATALOGUE

PART NUMBER	PART NAME	NO. REQ'D	MODEL	YEAR
<b>Cylinder and Engine Supports—Continued</b>				
++88452-S7	Stud-3/8"-24 & 3/8"-16 x 2-1/4" -water pump to cyl. block	1	9L,9H	49
++88512-S7	Stud-3/8"-24 and 3/8"-16 x 3" -water pump to cylinder block	1	9L,9H	49
8EL-6654	Spring (front oil relief valve)- 21/64" I.D. x 27/32" long-7 coils	1	9L,9H,OL,OH,1L,1H	49-51
8EL-6663	Plunger (front oil relief valve)- 7/16" O.D. x 21/32" long	1	9L,9H,OL,OH,1L,1H	49-51
8EL-6666	Cap (hex-hd)-13/16"-16 x 45/64" -front oil relief valve	1	9L,9H,OL,OH,1L,1H	49-51
9N-8115	Cook assy (drain)-straight type	2	9L,9H,OL,OH,1L,1H	49-51

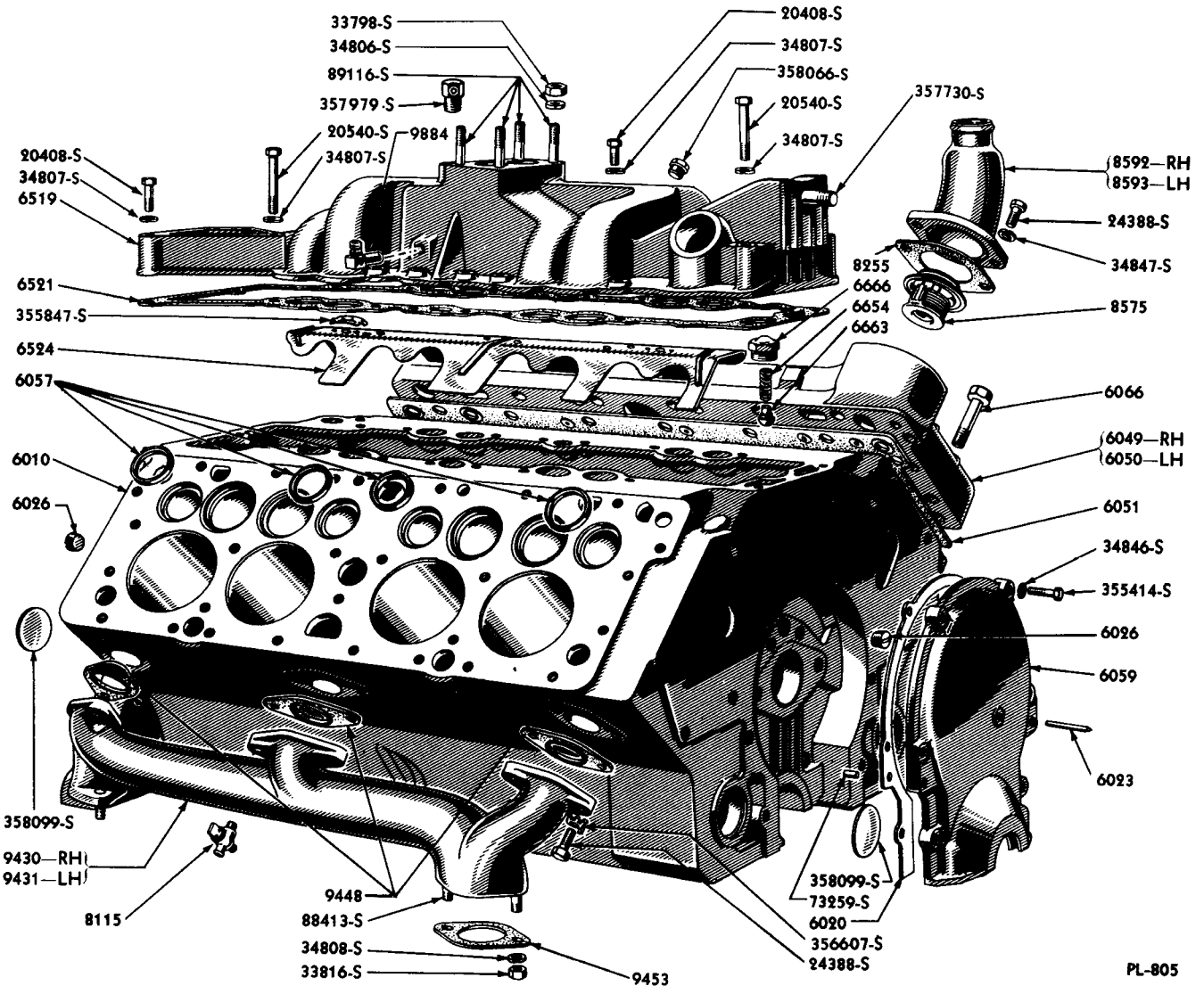

### CYLINDER BLOCK AND RELATED PARTS

Basic numbers only shown on illustration. Order by Part Numbers shown in list of parts.

PL-805

++ Not used with HYDRA-MATIC transmission

# Lincoln and Lincoln Cosmopolitan

## CHASSIS PARTS CATALOGUE

PART NUMBER	PART NAME	NO. REQ'D	MODEL	YEAR
<b>Cylinder and Engine Supports—Continued</b>				
8EL 6011-A	Cylinder assy	1	9L,9H	49
8EL 6011-C	Cylinder assy-with undercut between cylinder bores and intake ports	1	9L,9H	49
8EL 6011-D	NS Cylinder assy-with undercut between cyl. bores and intake ports-includes 8EL-6394-B-replaced by 1EL-6009-B	1	9L,9H,OL,OH	49-50
8EL 6020	Gasket (cylinder front cover)	1	9L,9H,OL,OH,1L,1H	49-51
8EL 6023	Pointer (timing)	1	9L,9H,OL,OH,1L,1H	49-51
18 6026-A	Plug (tapered thread)-1/4"-18-tappet oil line	2	9L,9H,OL,OH,1L,1H	49-51
7HA 6026-A	Plug (tapered thread)-3/8"-18 x 25/64" thick-cylinder block main oil line-front	1	9L,9H,OL,OH,1L,1H	49-51
8EL 6026	Plug (tapered thread)-3/8"-18-cylinder block oil line-rear-use when hole in block is threaded	1	9L,9H	49
1GA 6026-A	Plug (tapered thread)-3/8"-18 x 5/16" thick-cylinder block main oil line-front	1	1L,1H	51

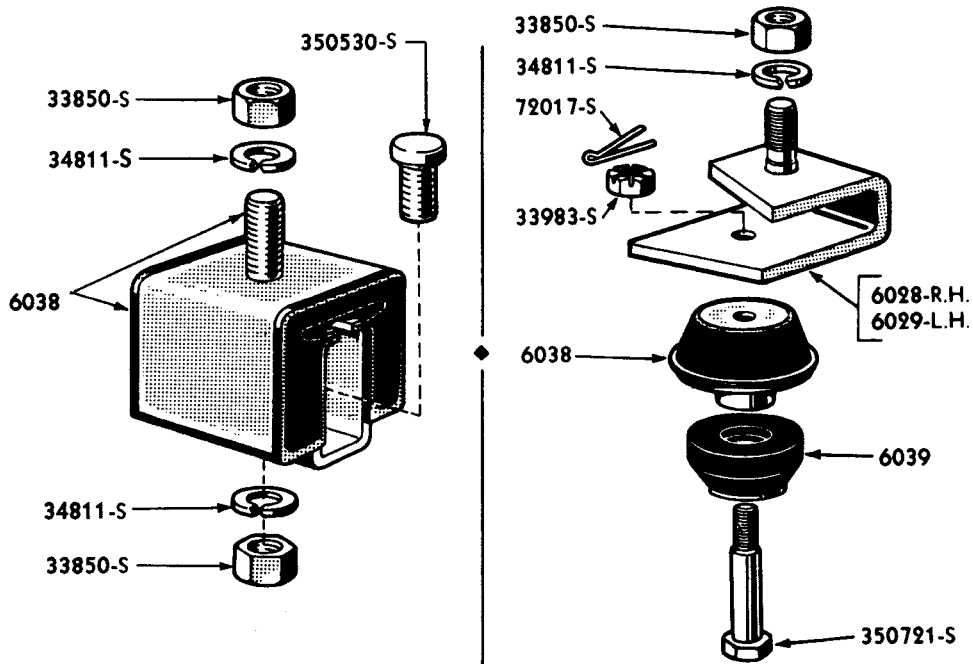

PL-459

### ENGINE FRONT SUPPORTS

Basic numbers only shown on illustration. Order by Part Numbers shown in list of parts.

+ Used with HYDRA-MATIC transmission

++ Not used with HYDRA-MATIC transmission

# Lincoln and Lincoln Cosmopolitan

## CHASSIS PARTS CATALOGUE

PART NUMBER	PART NAME	NO. REQ'D	MODEL	YEAR 19
<b>Cylinder and Engine Supports—Continued</b>				
*8M 6028	Bracket assy (engine front support)-R.H.	1	9L,9H,OL,OH,1L,1H	49-51
HAK 6028-A	Kit (frame conversion)-engine front supports- consists of the following (1) 8M-6028 Bracket (1) 8M-6029 Bracket (2) 8L-6038-B Insulator (2) 8L-6039 Insulator (2) 34811-S2 Washer (2) 33850-S2 Nut (2) 33983-S7 Nut (2) 350721-S8 Bolt	1	9L,9H,OL,OH,1L,1H	49-51
*8M 6029	Bracket assy (engine front support)-L.H.	1	9L,9H,OL,OH,1L,1H	49-51
**8L 6038-A	Support assy (engine front)	2	9L,9H	49
*8L 6038-B	Insulator assy (engine front support)-upper	2	9L,9H,OL,OH,1L,1H	49-51
	350530-S8B Bolt (shoulder)-5/8"-18 x 1-1/16"-support to frame- used with 8L-6038-A	2	9L,9H	49
	34811-S2 Lockwasher-5/8"-support to engine	2	9L,9H,OL,OH,1L,1H	49-51
	34811-S2 Lockwasher-5/8"-support to frame-used with 8L-6038-A	2	9L,9H	49
	33850-S2 Nut (hex)-5/8"-18-support to engine	2	9L,9H,OL,OH,1L,1H	49-51
	33850-S2 Nut (hex)-5/8"-18-support to frame-used with 8L-6038-A	2	9L,9H	49
*8L 6039	Insulator assy (engine rear support rebound)-lower	1	9L,9H,OL,OH,1L,1H	49-51
*8L 6039	Insulator assy (engine front support rebound)-lower	2	9L,9H,OL,OH,1L,1H	49-51
	*350721-S8 Bolt (hex head shoulder)-1/2"- 20 x 3-1/4"	2	9L,9H,OL,OH,1L,1H	49-51
	*72017-S Cotter pin-1/8" x 3/4"	2	9L,9H,OL,OH,1L,1H	49-51
	*33983-S7 Nut (hex slotted)-1/2"-20	2	9L,9H,OL,OH,1L,1H	49-51
8EL 6049-B	Head (cylinder)-RH	1	9L,9H,OL,OH,1L,1H	49-51
	358066-S8 Plug (tapered pipe thread)-3/8" -cyl. head heater connection	2	9L,9H,OL,OH,1L,1H	49-51
8EL 6050-B	Head (cylinder)-LH	1	9L,9H,OL,OH,1L,1H	49-51
	351025-S7 Nut (hex)-7/16"-20-cylinder head to block	49	9L,9H	49
	352771-S Stud-7/16"-20 and 7/16"-14 x 3-11/64"-cyl. head to block	54	9L,9H	49
	8BA-6066-A Bolt (cyl. head)-7/16"-14 x 2-5/8"	54	9L,9H,OL,OH,1L,1H	49-51
	8A-10884 Bulb assy (electric heat indicator) -single terminal	1	9L,9H,OL,OH,1L,1H	49-51
	8A-10990 Bulb assy (excessive heat indicator) -two terminals	1	9L,9H,OL,OH,1L,1H	49-51
	34802-S7 Lockwasher-No. 8	2	9L,9H,OL,OH,1L,1H	49-51
	27687-S Screw (round head)-No. 8-32 x 3/16"-wiring to excessive heat indicator	2	9L,9H,OL,OH,1L,1H	49-51
8EL 6051-D	NS Gasket (cylinder head)-replaced by OEL-6051	2	9L,9H,OL,OH	49-50
OEL 6051	Gasket (cylinder head)-1/16" thick-w/o tab at end	2	OL,OH,1L,1H	50-51
*LEL 6051-A	Gasket (cylinder head)-5/64" thick-with tab at end	2	9L,9H,OL,OH,1L,1H	49-51

\* Used with Frames 8H-5005-C, 8H-5005-D, 8L-5005-D also Front Cross Member Assemblies 8L-5019-B and 8H-5019-B.

\*\* Used with Frames 8H-5005-A, 8H-5005-B, 8L-5005-A, 8L-5005-C also Front Cross Member Assemblies 8L-5019-A and 8H-5019-A.

# Lincoln and Lincoln Cosmopolitan

## CHASSIS PARTS CATALOGUE

PART NUMBER	PART NAME	NO. REQ'D	MODEL	YEAR
<b>Cylinder and Engine Supports—Continued</b>				
✚ 8L 6054-A	Plate assy (engine rear support)-5-27/64" long x 3" wide	1	9L,9H,OL,OH,1L,1H	49-51
✚✚ 8L 6054-B	Plate assy (engine rear support adapter)-5-13/16" long x 5-1/4" wide	1	9L,9H,OL,OH,1L,1H	49-51
HAK 6054-A	Kit (frame conversion)-engine rear supports-consists of the following (1) 8M-2153-A Bracket (1) 8L-6039 Insulator (1) 8L-6054-B Plate (1) 8L-6068-D Insulator (1) 8L-66073 "U" Bolt (1) 24389-S8 Bolt (1) 34445-S7 Locknut (3) 34449-S7 Nut (2) 34809-S2 Lockwasher (1) 356474-S8 Washer (2) 20392-S Nut	1	9L,9H,OL,OH,1L,1H	49-51
	20350-S7 Bolt (hex)-7/16"-14 x 3/4"-used with 8L-6054-A only	2	9L,9H,OL,OH,1L,1H	49-51
	✚✚ 20392-S Bolt (hex-hd)-2"-13 x 1"-support to transmission	2	9L,9H,OL,OH,1L,1H	49-51
	34449-S7 Locknut (hex)-1/2"-20	lor3	9L,9H,OL,OH,1L,1H	49-51
	34808-S7 Lockwasher-7/16"-used with 8L-6054-A only	2	9L,9H,OL,OH,1L,1H	49-51
	✚✚ 34809-S8 Lockwasher-1/2"-support to transmission	2	9L,9H,OL,OH,1L,1H	49-51
	356474-S8 Washer (flat)-1/2" I.D. x 1" O.D. x 7/64" thick	1	9L,9H,OL,OH,1L,1H	49-51
	8L-6039 Insulator assy (engine rear support rebound)-lower	1	9L,9H,OL,OH,1L,1H	49-51
	8L-6068-D Insulator assy (engine rear support)-upper-use with 8L-6054-B	1	9L,9H,OL,OH,1L,1H	49-51
	✚✚ 8L-66073 "U" Bolt (engine rear support)-1/2"-20-used with 8L-6054-B Plate	1	9L,9H,OL,OH,1L,1H	49-51
8EL 6057-A	Insert (exhaust valve seat)	8	9L,9H,OL,OH,1L,1H	49-51
8EL 6057-C	Insert (exhaust valve seat)	8	9L,9H,OL,OH,1L,1H	49-51
8EL 6059-A1	Cover (cylinder front)-Cast Iron	1	9L,9H,OL,OH,1L,1H	49-51
8EL 6059-A2	Cover (cylinder front)-Aluminum Die Cast	1	9L,9H,OL,OH,1L,1H	49-51
	355414-S7 Bolt (hex-hd)-5/16"-18 x 15/16"-cover to cylinder block	6	9L,9H,OL,OH,1L,1H	49-51
	34846-S2 Lockwasher-5/16"-cover to cylinder block	6	9L,9H,OL,OH,1L,1H	49-51
	73259-S Pin (dowel)-3/8" diameter x 1/2" long	2	9L,9H,OL,OH,1L,1H	49-51
8BA 6066-A	Bolt (cylinder head)-7/16"-14 x 2-5/8"	54	9L,9H,OL,OH,1L,1H	49-51

✚ Used with HYDRA-MATIC transmission.

✚✚ Not used with HYDRA-MATIC transmission - Used when replacing Frames 8H-5005-A with 8H-5005-C, 8H-5005-B with 8H-5005-D, 8L-5005-A with 8L-5005-D.

# Lincoln and Lincoln Cosmopolitan

## CHASSIS PARTS CATALOGUE

### Cylinder and Engine Supports—Continued

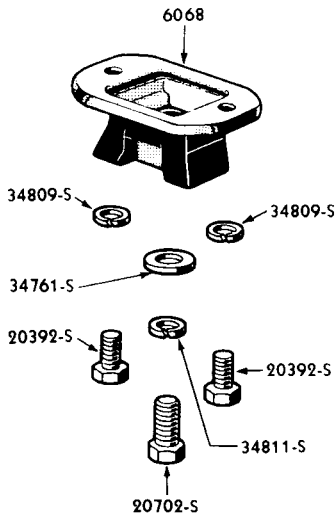

9L, 9H,  
USED WITH 8H-5005-A & B FRAMES  
USED WITH 8L-5005-A, B & C FRAMES

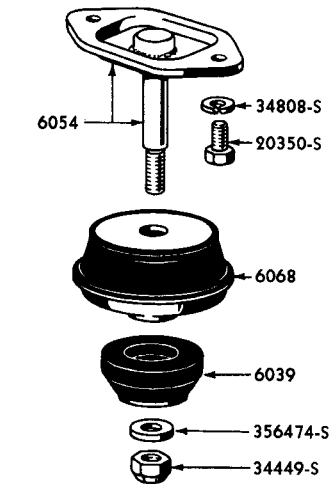

9L, 9H, 0H, 0L, 1L, 1H,  
+USED WITH 8H-5005-C & D FRAMES  
+USED WITH 8L-5005-D FRAME

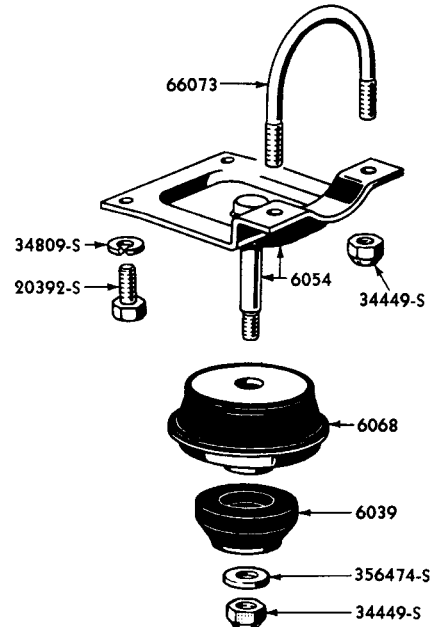

9L, 9H, 0L, 0H, 1L, 1H,  
++USED WHEN REPLACING 8H-5005-A FRAME  
WITH 8H-5005-C FRAME  
++USED WHEN REPLACING 8H-5005-B FRAME  
WITH 8H-5005-D FRAME  
++USED WHEN REPLACING 8L-5005-A FRAME  
WITH 8L-5005-D FRAME

## ENGINE REAR SUPPORTS

PL-806

Basic numbers only shown on illustration. Order by Part Numbers shown in list of parts.

PART NUMBER	UNIT	PART NAME	NO. REQ'D	MODEL	YEAR
**8L 6068-B		Support assy (engine rear)-5-11/16" long x 2-31/32" wide x 1-29/32" high	1	9L, 9H	49
		20702-S Bolt (hex-hd)-5/8"-18 x 1-1/4" support to frame	1	9L, 9H	49
		34811-S2 Lockwasher-5/8"-support to frame	1	9L, 9H	49
		34761-S7 Washer (flat)-5/8"-support to frame	1	9L, 9H	49
*8L 6068-D		Insulator assy (engine rear support)-upper-o/all height 1-59/64"-4-1/16" O.D.	1	9L, 9H, 0L, 0H, 1L, 1H	49-51
8L 6071	NS	Anti squeak (engine rear support insulator)-Rubber 1-5/16" I.D. x 3-19/32" O.D. x 1/16" thick-secure locally	1	9L, 9H, 0L, 0H, 1L, 1H	49-51
8EL 6073-A	NS	Tee (oil pressure gauge indicator)-for 1/4" flared tube & 1/4" pipe thread-repl. by OEL-6073	1	9L, 9H	49
OEL 6073		Tee assy (oil pressure gauge indicator relief valve)-with 1/4"-18 and 7/16"-14 tapped holes	1	0L, 0H, 1L, 1H	50-51
HBK 6079-A		Kit (cylinder head gasket)-consists of the following (2) OEL-6051 Gasket (1) 8EL-6521 Gasket	1	9L, 9H, 0L, 0H, 1L, 1H	49-51

\* Used with Frames 8H-5005-C, 8H-5005-D and 8L-5005-D.

\*\* Used with Frames 8H-5005-A, 8H-5005-B, 8L-5005-A and 8L-5005-C.

# Lincoln and Lincoln Cosmopolitan

## CHASSIS PARTS CATALOGUE

### Piston and Connecting Rod

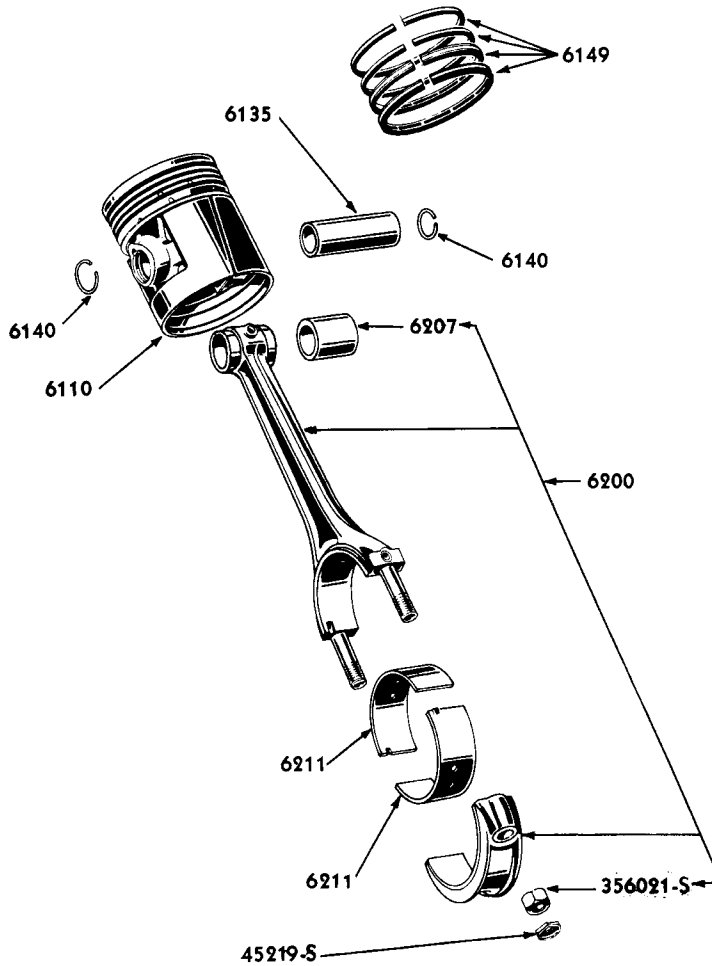

PL-585

### PISTON AND CONNECTING ROD

Basic numbers only shown on illustration. Order by Part Numbers shown in list of parts.

FART NUMBER	NS	PART NAME	NO. REQ'D	MODEL	YEAR 19
8EL 6110-A	NS	Piston-Standard-order 8EL-6110-G	8	9L,9H	49
8EL 6110-B	NS	Piston-.0025" O/S-order 8EL-6110-H	8	9L,9H	49
8EL 6110-C		Piston-.020" O/S-4 ring type	8	9L,9H	49
8EL 6110-D		Piston-.030" O/S-4 ring type	8	9L,9H	49
8EL 6110-E		Piston-.040" O/S-4 ring type	8	9L,9H	49
8EL 6110-G		Piston-Standard-4 ring type	8	9L,9H	49
8EL 6110-H		Piston-.0025" O/S-4 ring type	8	9L,9H	49
OEL 6110-A		Piston-Standard-3 ring type	8	OL,OH,1L,1H	50-51
OEL 6110-B		Piston-.0025" O/S-3 ring type	8	OL,OH,1L,1H	50-51
OEL 6110-C		Piston-.020" O/S-3 ring type	8	OL,OH,1L,1H	50-51
OEL 6110-D		Piston-.030" O/S-3 ring type	8	OL,OH,1L,1H	50-51
OEL 6110-E		Piston-.040" O/S-3 ring type	8	OL,OH,1L,1H	50-51

# Lincoln and Lincoln Cosmopolitan

## CHASSIS PARTS CATALOGUE

PART NUMBER	PART NAME	NO. REQ'D	MODEL	YEAR
<b>Piston and Connecting Rod—Continued</b>				
8EL 6135-A	Pin (piston)-Standard-marked with Green paint	8	9L,9H,OL,OH,1L,1H	49-51
8EL 6135-B	Pin (piston)-.001" O/S-marked with Blue paint	8	9L,9H,OL,OH,1L,1H	49-51
8EL 6135-C	Pin (piston)-.002" O/S-marked with Yellow paint	8	9L,9H,OL,OH,1L,1H	49-51
7HA 6140	Retainer (piston pin)	16	9L,9H,OL,OH,1L,1H	49-51
●8EL 6149-F	Ring set (piston)-Standard-4 ring type piston	1	9L,9H	49
●8EL 6149-G	Ring set (piston)-.020" O/S-4 ring type piston	1	9L,9H	49
●8EL 6149-H	Ring set (piston)-.030" O/S-4 ring type piston	1	9L,9H	49
●8EL 6149-J	Ring set (piston)-.040" O/S-4 ring type piston	1	9L,9H	49
●8ELS 6149-A	Ring set (piston)-Standard-4 ring type piston	1	9L,9H	49
●8ELS 6149-B	Ring set (piston)-.020" O/S-4 ring type piston	1	9L,9H	49
●8ELS 6149-C	Ring set (piston)-.030" O/S-4 ring type piston	1	9L,9H	49
●8ELS 6149-D	Ring set (piston)-.040" O/S-4 ring type piston	1	9L,9H	49
●OELS 6149-A	Ring set (piston)-Standard-3 ring type piston	1	OL,OH,1L,1H	50-51
●OELS 6149-B	Ring set (piston)-.020" O/S-3 ring type piston	1	OL,OH,1L,1H	50-51
●OELS 6149-C	Ring set (piston)-.030" O/S-3 ring type piston	1	OL,OH,1L,1H	50-51
●OELS 6149-D	Ring set (piston)-.040" O/S-3 ring type piston	1	OL,OH,1L,1H	50-51
●OELS 6149-E	Ring set (piston)-Standard-3 ring type piston	1	OL,OH,1L,1H	50-51
●OELS 6149-F	Ring set (piston)-.020" O/S-3 ring type piston	1	OL,OH,1L,1H	50-51
●OELS 6149-G	Ring set (piston)-.030" O/S-3 ring type piston	1	OL,OH,1L,1H	50-51
●OELS 6149-H	Ring set (piston)-.040" O/S-3 ring type piston	1	OL,OH,1L,1H	50-51
OEL 6178	Tube assy (cylinder block water)-RH-23-1/8" o/all length	1	1L,1H	51
OEL 6179	Tube assy (cylinder block water)-LH-22" o/all length	1	1L,1H	51
8EL 6200	Rod assy (connecting)	8	9L,9H,OL,OH,1L,1H	49-51
	356021-S Nut (hex)-7/16"-20	16	9L,9H,OL,OH,1L,1H	49-51
	45219-S Nut (stamped)-7/16"-20	16	9L,9H,OL,OH,1L,1H	49-51
2GA 6207-B	Bushing (piston pin)-53/64" I.D. x 1-19/64" long	8	9L,9H,OL,OH,1L,1H	49-51
8EL 6211-A	Bearing (connecting rod)-Standard-Copper Lead base	16	9L,9H,OL,OH	49-50
8EL 6211-B	Bearing (connecting rod)-.002" U/S-Copper Lead base	16	9L,9H,OL,OH	49-50
8EL 6211-C	Bearing (connecting rod)-.010" U/S-Copper Lead base	16	9L,9H,OL,OH	49-50
8EL 6211-D	Bearing (connecting rod)-.020" U/S-Copper Lead base	16	9L,9H,OL,OH	49-50
8EL 6211-E	Bearing (connecting rod)-.030" U/S-Copper Lead base	16	9L,9H,OL,OH	49-50
8EL 6211-F	Bearing (connecting rod)-.040" U/S-Copper Lead base	16	9L,9H,OL,OH	49-50
OEL 6211-A	Bearing (connecting rod)-Standard-Lead base	16	9L,9H,OL,OH,1L,1H	49-51
OEL 6211-B	Bearing (connecting rod)-.002" U/S-Lead base	16	9L,9H,OL,OH,1L,1H	49-51
OEL 6211-C	Bearing (connecting rod)-.010" U/S-Lead base	16	9L,9H,OL,OH,1L,1H	49-51
OEL 6211-D	Bearing (connecting rod)-.020" U/S-Lead base	16	9L,9H,OL,OH,1L,1H	49-51
OEL 6211-E	Bearing (connecting rod)-.030" U/S-Lead base	16	9L,9H,OL,OH,1L,1H	49-51
OEL 6211-F	Bearing (connecting rod)-.040" U/S-Lead base	16	9L,9H,OL,OH,1L,1H	49-51
7HA 6212	Nut (hex-hd slotted)-3/8"-24-drive shaft to rear axle assy	4	9L,9H,OL,OH	49-50

● Basic number 6149 contains the necessary compression and oil control rings to re-ring one engine



# Lincoln and Lincoln Cosmopolitan

## CHASSIS PARTS CATALOGUE

### Camshaft and Crankshaft

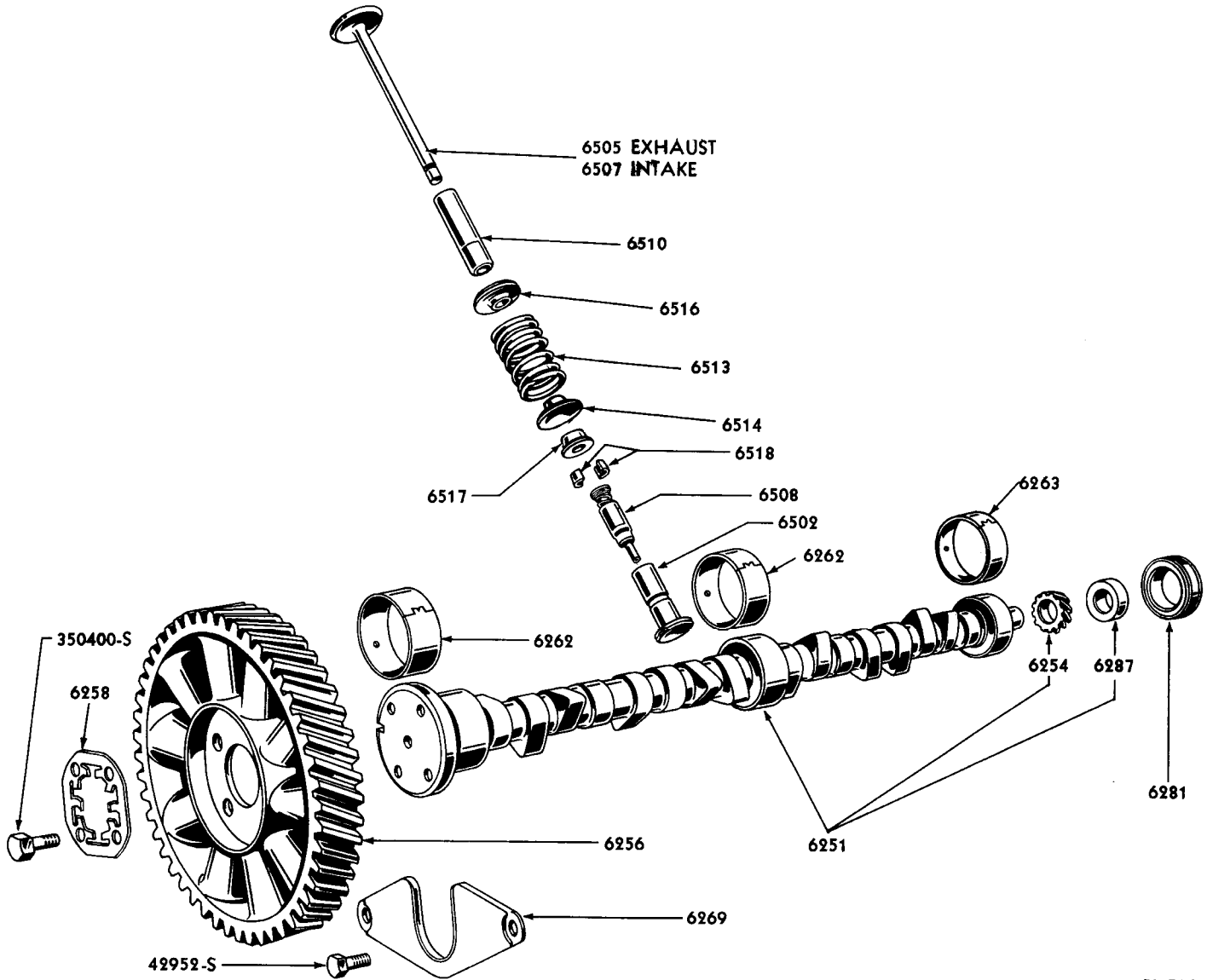

PL-786

### CAMSHAFT, GEAR, BEARINGS, ETC. (8EL)

Basic numbers only shown on illustration. Order by Part Numbers shown in list of parts.

PART NUMBER	CLAS	PART NAME	NO. REQ'D	MODEL	YEAR
8EL 6251-B		Camshaft assy	1	9L,9H,OL,OH,LL,1H	19 49-51
8EL 6254-B		Gear (oil pump drive)-43/64" I.D. x 1-11/32" O.D. x 35/64" thick-12 teeth-on rear end of camshaft	1	9L,9H,OL,OH,LL,1H	49-51
1GA 6256-A		Gear (camshaft)-Standard-48 teeth-Aluminum-alternate with 1GA-6256-D	1	9L,9H,OL,OH,LL,1H	49-51
1GA 6256-B		Gear (camshaft)-.006" O/S-48 teeth-Aluminum-alternate with 1GA-6256-E	1	9L,9H,OL,OH,LL,1H	49-51
1GA 6256-C		Gear (camshaft)-.012" O/S-48 teeth-Aluminum-alternate with 1GA-6256-F	1	9L,9H,OL,OH,LL,1H	49-51

# Lincoln and Lincoln Cosmopolitan

## CHASSIS PARTS CATALOGUE

PART NUMBER	PART NAME	NO. REQ'D	MODEL	YEAR 19__
<b>Camshaft and Crankshaft—Continued</b>				
1GA 6256-D	Gear (camshaft)-Standard-48 teeth-Fibre-alternate with 1GA-6256-A	1	9L, 9H, OL, OH, 1L, 1H	49-51
1GA 6256-E	Gear (camshaft)-.006" O/S-48 teeth-Fibre-alternate with 1GA-6256-B	1	9L, 9H, OL, OH, 1L, 1H	49-51
1GA 6256-F	Gear (camshaft)-.012" O/S-48 teeth-Fibre-alternate with 1GA-6256-C	1	9L, 9H, OL, OH, 1L, 1H	49-51
	350400-S Bolt (hex-hd)-5/16"-24 x 39/64" -camshaft gear to camshaft	4	9L, 9H, OL, OH, 1L, 1H	49-51
91A 6258	Ring (camshaft gear locking)	1	9L, 9H, OL, OH, 1L, 1H	49-51
8EL 6262-C	Bearing (camshaft front & intermediate)-Standard I.D. and Standard O.D.-finished	2	9L, 9H, OL, OH, 1L, 1H	49-51
8EL 6262-D	Bearing (camshaft front & intermediate)-Standard I.D. and .080" O/S O.D.-finished	2	9L, 9H, OL, OH, 1L, 1H	49-51
8EL 6262-E	Bearing (camshaft front & intermediate)-.015" U/S I.D. and Standard O.D.-must be reamed finished in assembly	2	9L, 9H, OL, OH, 1L, 1H	49-51
8EL 6263-C	Bearing (camshaft rear)-Standard I.D. and Std. O.D.-finished	1	9L, 9H, OL, OH, 1L, 1H	49-51
8EL 6263-D	Bearing (camshaft rear)-Std. I.D. and .080" O/S O.D.-finished	1	9L, 9H, OL, OH, 1L, 1H	49-51
8EL 6263-E	Bearing (camshaft rear)-.015" U/S I.D. and Std. O.D.-must be reamed finished in assembly	1	9L, 9H, OL, OH, 1L, 1H	49-51
8EL 6269-A	Plate (camshaft thrust)	1	9L, 9H, OL, OH, 1L, 1H	49-51
	42952-S Bolt (hex head self locking)-5/16"-18 x 1/2"-camshaft plate to cylinder block	2	9L, 9H, OL, OH, 1L, 1H	49-51
8EL 6281-A	Bushing assy (camshaft fuel pump drive eccentric)-with bearing	1	9L, 9H, OL, OH	49-50
8EL 6281-B	Bushing assy (camshaft fuel pump drive eccentric)-without bearing	1	9L, 9H, OL, OH, 1L, 1H	49-51
8EL 6287-B	Eccentric (fuel pump drive camshaft)	1	9L, 9H, OL, OH, 1L, 1H	49-51
++8FL 6303-B	Crankshaft and plugs assy	1	9L, 9H, OL, OH, 1L, 1H	49-51
+8EL 6303-C	Crankshaft, plugs, pilot bearing and retainer assy	1	9L, 9H, OL, OH, 1L, 1H	49-51
	357985-S Plug (std. pipe thread)-1/2"	4	9L, 9H, OL, OH, 1L, 1H	49-51
	+8L-7938 Bearing (trans. pilot)-Bronze-19/32" I.D. x 1-3/32" O.D. x 3/4" thick	1	9L, 9H, OL, OH, 1L, 1H	49-51
	+8L-7942 Retainer (trans. pilot bearing)-19/32" I.D. x 1-37/64" O.D. x 7/32" deep	1	9L, 9H, OL, OH, 1L, 1H	49-51
HAK 6303-A	Kit (crankshaft conversion)-consists of the following (1) 8EL-6303-B C/shaft (2) 8L-7936 Bearing (1) 8L-7942 Retainer	1	9L, 9H, OL, OH, 1L, 1H	49-51
1GA 6306-B	Gear (crankshaft)-24-LH helical teeth	1	9L, 9H, OL, OH, 1L, 1H	49-51
	356658-S Key (woodruff)-7/8" x 1/4"	1	9L, 9H, OL, OH, 1L, 1H	49-51
8EL 6310	Slinger (crankshaft oil)-1-5/16" I.D. x 2-7/8" O.D. x 1/4" deep	1	9L, 9H, OL, OH, 1L, 1H	49-51

+ Used with HYDRA-MATIC transmission

++ Not used with HYDRA-MATIC transmission

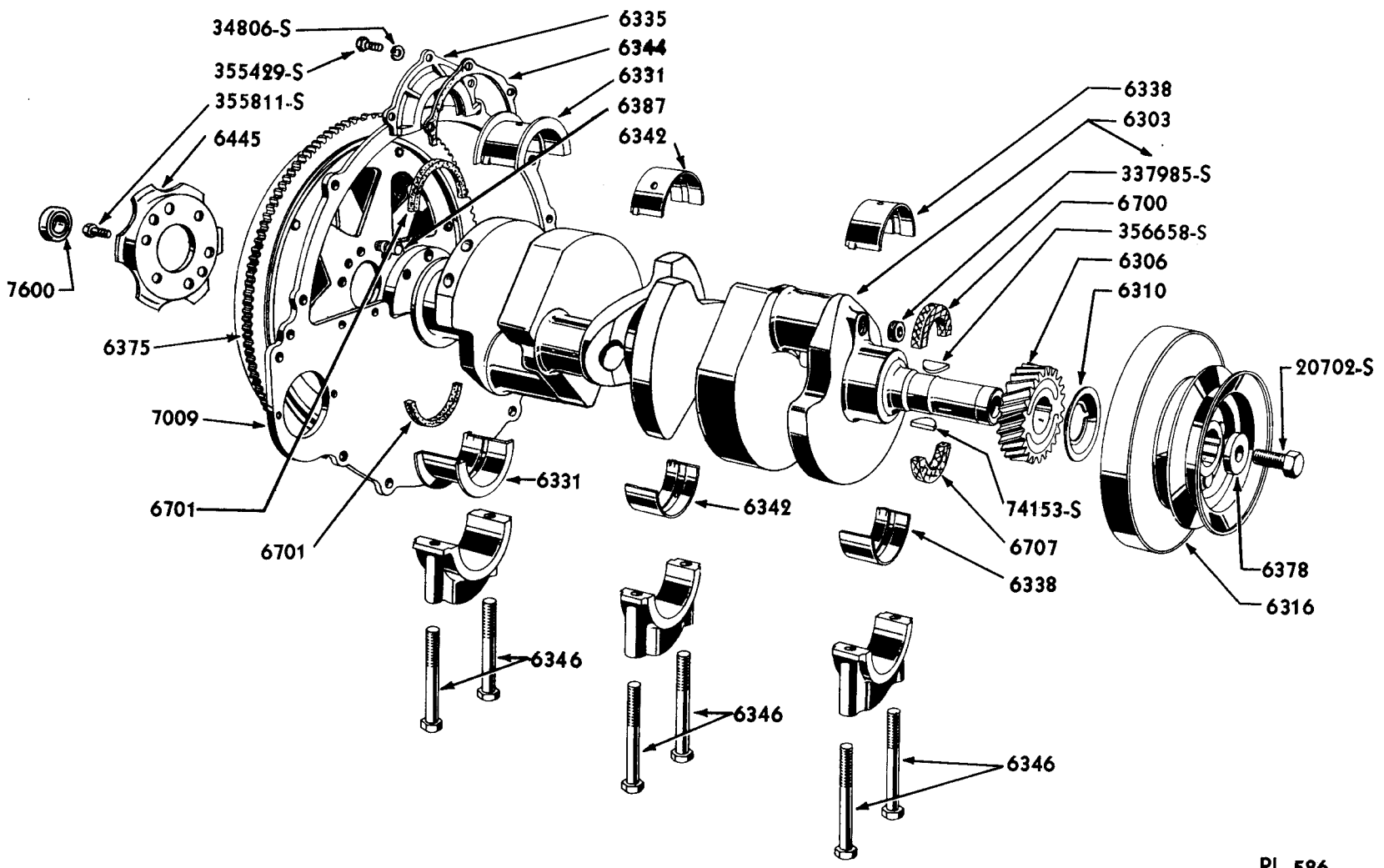

**CRANKSHAFT, FLYWHEEL AND RELATED PARTS**

Basic numbers only shown on illustration. Order by Part Numbers shown in list of parts.

PL-586

# Lincoln and Lincoln Cosmopolitan

## CHASSIS PARTS CATALOGUE

PART NUMBER	PART NAME	NO. REQ'D	MODEL	YEAR 19__
<b>Camshaft and Crankshaft—Continued</b>				
8EL 6316-A	Dampener assy (vibration)-has two piece brazed pulley-uses wide belt	1	9L, 9H	49
8EL 6316-B	Dampener assy (vibration)-has one piece pulley-uses narrow belt	1	9L, 9H, 0L, 0H	49-50
OEL 6316	Dampener assy (vibration)-pulley & dampener intergral-uses narrow belt	1	9L, 9H, 0L, 0H, 1L, 1H	49-51
	20702-S Bolt (hex-hd)-5/8"-18 x 1-7/16" -vibration dampener to crankshaft	1	9L, 9H, 0L, 0H, 1L, 1H	49-51
	74153-S Key (woodruff)-1" x 1/4"	1	9L, 9H, 0L, 0H, 1L, 1H	49-51
	8EL-6378 Washer (plain special)-1.520" x .66" x .209"-vibration dampener assy to crankshaft	1	9L, 9H, 0L, 0H, 1L, 1H	49-51

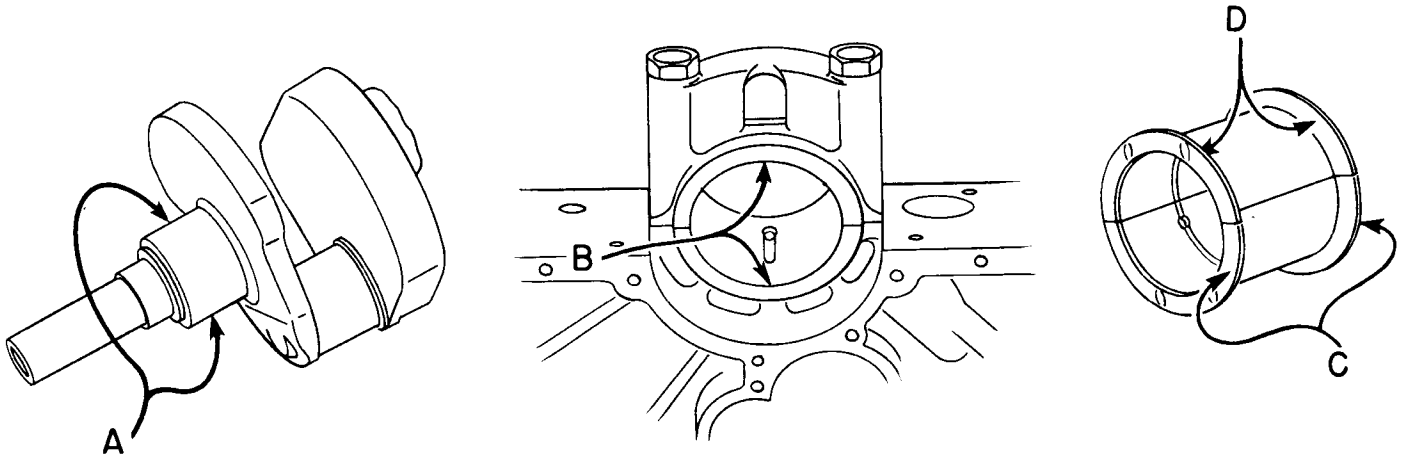

PL-319

### REAR MAIN BEARING LINER CHART

PART NUMBER	CLASS	A CRANKSHAFT DIAMETER	B CYLINDER BLOCK MAIN BEARING BORE	C OVERALL LENGTH	D LENGTH BETWEEN FLANGES	NO. REQ'D
8EL 6331-A		2.8735"/2.8740" (Std)	3.066"/3.067" (Std)	2.397"/2.399" (Std)	2.199"/2.201" (Std)	2
8EL 6331-B		.002" U/S	3.066"/3.067" (Std)	2.397"/2.399" (Std)	2.199"/2.201" (Std)	2
8EL 6331-C		.010" U/S	3.066"/3.067" (Std)	2.397"/2.399" (Std)	2.199"/2.201" (Std)	2
8EL 6331-D		.020" U/S	3.066"/3.067" (Std)	2.397"/2.399" (Std)	2.199"/2.201" (Std)	2
8EL 6331-E		.030" U/S	3.066"/3.067" (Std)	2.397"/2.399" (Std)	2.199"/2.201" (Std)	2
8EL 6331-F		.040" U/S	3.066"/3.067" (Std)	2.397"/2.399" (Std)	2.199"/2.201" (Std)	2
OEL 6331-A		2.8735"/2.8740" (Std)	3.066"/3.067" (Std)	2.397"/2.399" (Std)	2.199"/2.201" (Std)	2
*OEL 6331-B	NS	.002" U/S	3.066"/3.067" (Std)	2.397"/2.399" (Std)	2.199"/2.201" (Std)	2
OEL 6331-C		.010" U/S	3.066"/3.067" (Std)	2.397"/2.399" (Std)	2.199"/2.201" (Std)	2
OEL 6331-D		.020" U/S	3.066"/3.067" (Std)	2.397"/2.399" (Std)	2.199"/2.201" (Std)	2
OEL 6331-E		.030" U/S	3.066"/3.067" (Std)	2.397"/2.399" (Std)	2.199"/2.201" (Std)	2
OEL 6331-F		.040" U/S	3.066"/3.067" (Std)	2.397"/2.399" (Std)	2.199"/2.201" (Std)	2

\* Replaced by OEL-6331-A

++ Not used with HYDRA-MATIC transmission

# Lincoln and Lincoln Cosmopolitan

## CHASSIS PARTS CATALOGUE

PART NUMBER	PART NAME	NO. REQ'D	MODEL	YEAR 19__
<b>Camshaft and Crankshaft—Continued</b>				
8EL 6335	Retainer (crankshaft rear bearing oil seal)	1	9L,9H,OL,OH,1L,1H	49-51
	355429-S Bolt (hex-hd shoulder)-5/16"-18 x 49/64"	3	9L,9H,OL,OH,1L,1H	49-51
	34806-S7 Lockwasher-5/16"	3	9L,9H,OL,OH,1L,1H	49-51

### FRONT MAIN BEARING LINER CHART

PART NUMBER	A CRANKSHAFT DIAMETER	B CYLINDER BLOCK MAIN BEARING BORE	C OVERALL LENGTH	NO. REQ'D
8EL 6338-A	2.8735"/2.8740" (Std)	3.066"/3.067" (Std)	1.344"/1.354" (Std)	2
8EL 6338-B	.002" U/S	3.066"/3.067" (Std)	1.344"/1.354" (Std)	2
8EL 6338-C	.010" U/S	3.066"/3.067" (Std)	1.344"/1.354" (Std)	2
8EL 6338-D	.020" U/S	3.066"/3.067" (Std)	1.344"/1.354" (Std)	2
8EL 6338-E	.030" U/S	3.066"/3.067" (Std)	1.344"/1.354" (Std)	2
8EL 6338-F	.040" U/S	3.066"/3.067" (Std)	1.344"/1.354" (Std)	2
OEL 6338-A	2.8735"/2.8740" (Std)	3.066"/3.067" (Std)	1.344"/1.354" (Std)	2
*OEL 6338-B NS	.002" U/S	3.066"/3.067" (Std)	1.344"/1.354" (Std)	2
OEL 6338-C	.010" U/S	3.066"/3.067" (Std)	1.344"/1.354" (Std)	2
OEL-6338-D	.020" U/S	3.066"/3.067" (Std)	1.344"/1.354" (Std)	2
OEL 6338-E	.030" U/S	3.066"/3.067" (Std)	1.344"/1.354" (Std)	2
OEL 6338-F	.040" U/S	3.066"/3.067" (Std)	1.344"/1.354" (Std)	2

### INTERMEDIATE MAIN BEARING LINER CHART

PART NUMBER	A CRANKSHAFT DIAMETER	B CYLINDER BLOCK MAIN BEARING BORE	C OVERALL LENGTH	NO. REQ'D
8EL 6342-A	2.8735"/2.8740" (Std)	3.066"/3.067" (Std)	1.470"/1.480" (Std)	2
8EL 6342-B	.002" U/S	3.066"/3.067" (Std)	1.470"/1.480" (Std)	2
8EL 6342-C	.010" U/S	3.066"/3.067" (Std)	1.470"/1.480" (Std)	2
8EL 6342-D	.020" U/S	3.066"/3.067" (Std)	1.470"/1.480" (Std)	2
8EL 6342-E	.030" U/S	3.066"/3.067" (Std)	1.470"/1.480" (Std)	2
8EL 6342-F	.040" U/S	3.066"/3.067" (Std)	1.470"/1.480" (Std)	2
OEL 6342-A	2.8735"/2.8740" (Std)	3.066"/3.067" (Std)	2.199"/2.201" (Std)	2
**OEL 6342-B NS	.002" U/S	3.066"/3.067" (Std)	2.199"/2.201" (Std)	2
OEL 6342-C	.010" U/S	3.066"/3.067" (Std)	2.199"/2.201" (Std)	2
OEL 6342-D	.020" U/S	3.066"/3.067" (Std)	2.199"/2.201" (Std)	2
OEL 6342-E	.030" U/S	3.066"/3.067" (Std)	2.199"/2.201" (Std)	2
OEL 6342-F	.040" U/S	3.066"/3.067" (Std)	2.199"/2.201" (Std)	2

PART NUMBER	PART NAME	NO. REQ'D	MODEL	YEAR 19__
8EL 6344-A	Gasket (crankshaft rear bearing oil seal)-has no flat spot on I.D.-Paper	1	9L,9H	49
8EL 6344-B	Gasket (crankshaft rear bearing oil seal)-has flat spot on I.D.-Paper	1	9L,9H,OL,OH,1L,1H	49-51
1EL 6344-A	Gasket (crankshaft rear bearing oil seal)-Cork Fibre	1	1L,1H	51
8EL 6346-A	Bolt (crankshaft bearing cap)-9/16"-12 x 4-3/16"	6	9L,9H,OL,OH,1L,1H	49-51
	34850-S Lockwasher-9/16"	6	9L,9H,OL,OH,1L,1H	49-51

\* Replaced by OEL-6338-A

\*\* Replaced by OEL-6342-A

# Lincoln and Lincoln Cosmopolitan

## CHASSIS PARTS CATALOGUE

PART NUMBER	PART NAME	NO. REQ'D	MODEL	YEAR
<b>Flywheel and Valves</b>				
+8EL 6366	Cover and seal assy (flywheel housing front dust)-18-29/32" wide	1	9L,9H,OL,OH,1L,1H	49-51
	+20310-S8 Bolt (hex-hd)-5/16"-18 x 1/2"	2	9L,9H,OL,OH,1L,1H	49-51
	+24346-S7 Bolt (hex-hd)-5/16"-18 x 3/4"	2	9L,9H,OL,OH,1L,1H	49-51
	+34806-S2 Lockwasher-5/16"	4	9L,9H,OL,OH,1L,1H	49-51
+8EL 6375-A	Flywheel assy	1	9L,9H,OL,OH,1L,1H	49-51
	+355811-S Bolt (hex head self locking)-7/16"-20 x 1"-flywheel to crankshaft	6	9L,9H,OL,OH,1L,1H	49-51
+8EL 6375-C	Flywheel assy	1	9L,9H,OL,OH,1L,1H	49-51
	+8EL-6379 Bolt (flywheel to crankshaft)-7/16"-20 x 13/16"	6	9L,9H,OL,OH,1L,1H	49-51
+8EL 6377	Gasket (flywheel to crankshaft)-2-7/16" I.D. x 4-51/64" O.D.	1	9L,9H,OL,OH,1L,1H	49-51
8EL 6378	Washer (plain special)-33/64" x 21/32" x 13/54"-vibration dampener to crankshaft	1	9L,9H,OL,OH,1L,1H	49-51
+8EL 6379	Bolt (flywheel to crankshaft)-7/16"-20 x 13/16"	6	9L,9H,OL,OH,1L,1H	49-51
+8EL 6387-B	Dowel (flywheel to crankshaft)-7/16"-20 x 1-11/32" long	2	9L,9H,OL,OH,1L,1H	49-51
+8EL 6387-C	Dowel (flywheel to crankshaft)-15/32" Std. O.D.-3/8"-24 x 1-9/32" long	2	9L,9H,OL,OH,1L,1H	49-51
+8EL 6387-E	Dowel (flywheel to crankshaft)-.015" O/S O.D.-3/8"-24 x 1-9/32" long	2	9L,9H,OL,OH,1L,1H	49-51
+8EL 6392	Housing assy (flywheel)	1	9L,9H,OL,OH,1L,1H	49-51
	24450-S8 Bolt (hex-hd)-7/16"-14 x 1-3/8"-flywheel hsg. to cyl. block	6	9L,9H,OL,OH,1L,1H	49-51
	20247-S Bolt (hex-hd)-7/16"-20 x 2-1/2"-flywheel housing to oil pan	2	9L,9H,OL,OH,1L,1H	49-51
	353027-AS7 Fitting (lubricator)-1/8"-check valve type	2	9L,9H	49
	34808-S8 Lockwasher-7/16"-flywheel housing to cylinder block	6	9L,9H,OL,OH,1L,1H	49-51
	34808-S8 Lockwasher-7/16"-flywheel housing to oil pan	2	9L,9H,OL,OH,1L,1H	49-51
	33802-S8 Nut (hex)-7/16"-20-flywheel housing to oil pan	2	9L,9H,OL,OH,1L,1H	49-51
+8EL-6394-C	Housing (flywheel)-with trans. pilot hole reamed to size	1	9L,9H,OL,OH,1L,1H	49-51
+8EL 6394-B	Housing (flywheel)-with trans. pilot hole reamed to size-counterbored	1	1L,1H	51
	+24430-S8 Bolt (hex head)-7/16"-14 x 1-1/4"-flywheel housing to cylinder block	4	9L,9H,OL,OH,1L,1H	49-51
	+20550-S8 Bolt (hex-head)-7/16"-14 x 2-3/4"-flywheel housing to cylinder block	2	9L,9H,OL,OH,1L,1H	49-51
	+34808-S8 Lockwasher-7/16"-flywheel housing to cylinder block	6	9L,9H,OL,OH,1L,1H	49-51
	+34809-S8 Lockwasher-1/2" flywheel-housing to transmission	4	9L,9H,OL,OH,1L,1H	49-51

+ Used with HYDRA-MATIC transmission

+ Not used with HYDRA-MATIC transmission

# Lincoln and Lincoln Cosmopolitan

## CHASSIS PARTS CATALOGUE

### Flywheel and Valves—Continued

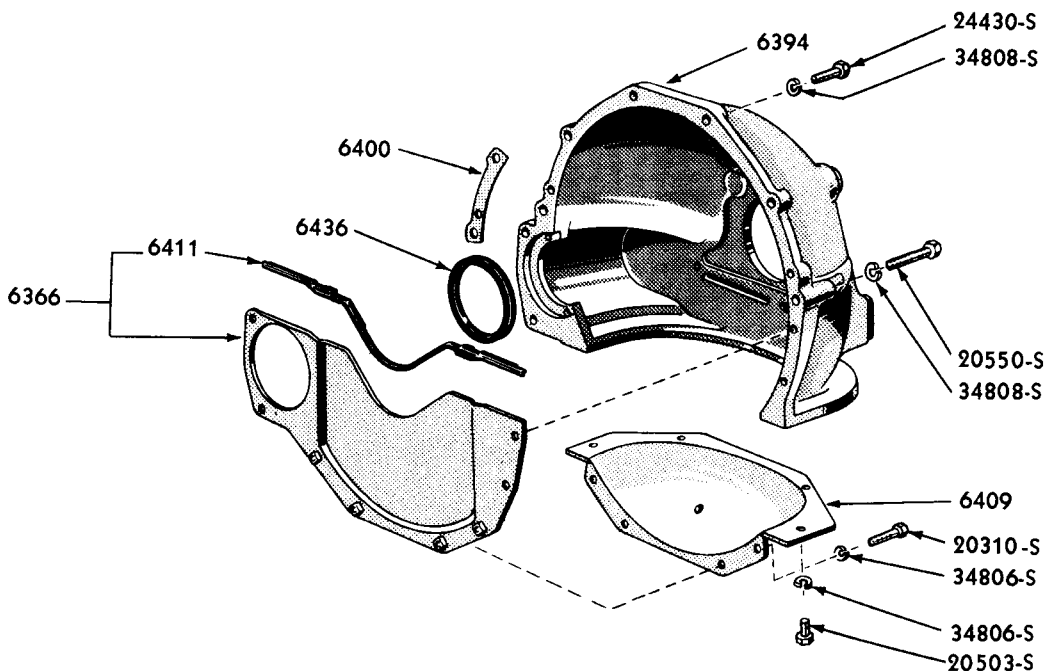

PL-787

### FLYWHEEL HOUSING AND RELATED PARTS (8EL-6394-C)

Basic numbers only shown on illustration. Order by Part Numbers shown in list of parts.

PART NUMBER	QUANTITY	PART NAME	NO. REQ'D	MODEL	YEAR
+8EL 6397-A		Dowel (cylinder block to flywheel housing)-3/8" x 3/32"	2	9L, 9H, 0L, 0H, 1L, 1H	49-51
+8EL 6397-B		Dowel (cylinder block to flywheel housing)-3/8" x 1"	2	9L, 9H, 0L, 0H, 1L, 1H	49-51
+8EL 6400		Shim (flywheel housing to cylinder block)-5-59/64" overall length-Steel	as reqd	9L, 9H, 0L, 0H, 1L, 1H	49-51
+8EL 6409		Cover (flywheel housing)-12-7/8" wide	1	9L, 9H, 0L, 0H, 1L, 1H	49-51
		+20303-S8 Bolt (hex-hd)-5/16"-24 x 3/8"	4	9L, 9H, 0L, 0H, 1L, 1H	49-51
		+20310-S8 Bolt (hex-hd)-5/16"-18 x 1/2"	4	9L, 9H, 0L, 0H, 1L, 1H	49-51
		+34806-S7 Lockwasher-5/16"	8	9L, 9H, 0L, 0H, 1L, 1H	49-51
+8EL 6411		Seal (flywheel housing front cover)-17-45/64" overall length-Rubber	1	9L, 9H, 0L, 0H, 1L, 1H	49-51
+8EL 6436		Seal (starter motor to dust cover)-3-1/2" I.D. x 3-23/32" O.D. x 5/32" thick-Rubber	1	9L, 9H, 0L, 0H, 1L, 1H	49-51
+8EL 6445		Retainer assy (flywheel to friction disc)	1	9L, 9H, 0L, 0H, 1L, 1H	49-51
8EL 6502-A		Body (hydraulic tappet)-.7183"/.7188" diameter	16	9L, 9H, 0L, 0H, 1L, 1H	49-51
8EL 6502-B		Body (hydraulic tappet)-.7490"/.7495" diameter	16	9L, 9H, 0L, 0H, 1L, 1H	49-51
8EL 6505-A		Valve (exhaust)-1.484" diameter of head	8	9L, 9H, 0L, 0H, 1L, 1H	49-51
8EL 6507-A		Valve (intake)-1.80" Standard diameter of head	8	9L, 9H, 0L, 0H, 1L, 1H	49-51
8EL 6507-B		Valve (intake)-.070" O/S diameter of head	8	9L, 9H, 0L, 0H, 1L, 1H	49-51
8EL 6508-A		Valve assy (hydraulic tappet check)	16	9L, 9H, 0L, 0H, 1L, 1H	49-51

+ Used with HYDRA-MATIC transmission

+ Not used with HYDRA-MATIC transmission

# Lincoln and Lincoln Cosmopolitan

## CHASSIS PARTS CATALOGUE

PART NUMBER	PART NAME	NO. REQ'D	MODEL	YEAR 19
<b>Flywheel and Valves—Continued</b>				
8EL 6510-A	Bushing (exhaust and intake guide)-11/32" I.D. x 47/64" O.D. x 2-21/32" long	16	9L,9H,OL,OH,1L,1H	49-51
8EL 6513	Spring (valve)-1-1/8" I.D. x 2-5/64" long-6 coils	16	9L,9H,OL,OH,1L,1H	49-51
8EL 6514	Retainer (valve spring)-lower-1-1/2" O.D. x 23/64" thick	16	9L,9H,OL,OH	49-50
**1EL 6514-A	Retainer (valve spring)-lower-1-1/2" O.D. x 7/16" thick	16	1L,1H	51
8EL 6516-B	Retainer (valve spring)-upper-3/4" I.D. x 1-29/64" O.D. x 25/64" thick	16	9L,9H,OL,OH,1L,1H	49-51
**1EL 6517-A	Sleeve (valve spring retainer)-7/8" max. O.D. x 17/32" O.D. at tapered end x 31/64" thick	16	1L,1H	51
7HA 6518	Key (valve spring retainer)-11/32" I.D. x 1/2" O.D. x 3/8" thick	32	9L,9H,OL,OH,1L,1H	49-51

## Intake Manifold

*8EL 6519	Manifold assy (intake)	1	9L,9H	49
*OEL 6519	Manifold assy (intake)	1	OL,OH,1L,1H	50-51
	20408-S7 Bolt (hex-hd)-3/8"-16 x 1-1/8"-intake manifold to cyl. block	as reqd	9L,9H,OL,OH,1L,1H	49-51
	24448-S8 Bolt (hex-hd)-3/8"-16 x 1-3/8"-intake manifold thru "Z" bar to cylinder block	1	OL,OH,1L,1H	50-51
	351704-S32 Clip (heat indicator cross over wiring to carburetor mounting stud)	1	9L,9H	49
	34307-S2 Lockwasher-3/8"-intake manifold to cylinder block	as reqd	9L,9H,OL,OH,1L,1H	49-51
	358050-S Plug (expansion)-1/2"	1	9L,9H,OL,OH,1L,1H	49-51
	74117-S Plug (expansion)-1"	2	9L,9H,OL,OH,1L,1H	49-51
	89116-S7 Stud-5/16"-24 and 5/16"-18 x 1-13/16"-carburetor to intake manifold	4	9L,9H,OL,OH,1L,1H	49-51
	352740-S7 Stud-9/16"-18 and 9/16"-12 x 2-39/64"-gen. brkt. to intake manifold	1	9L,9H,OL,OH,1L,1H	49-51
	B-9242 Ferrule (compression nut)-for 1/4" O.D. pipe	1	9L,9H,OL,OH,1L,1H	49-51
	357980-S Nut (hex compression)-for 1/4" O.D. pipe	1	9L,9H,OL,OH,1L,1H	49-51
	96H-9242 Ferrule (compression nut)-for 5/16" O.D. pipe	1	9L,9H,OL,OH,1L,1H	49-51
	358248-S Nut (hex-compression)-1/2"-20-for 5/16" diameter tube	1	9L,9H,OL,OH,1L,1H	49-51
	8EL-9819 Tube (thermostat choke control)-outlet-1/4" O.D. x 5-47/64" overall length	1	9L,9H,OL,OH,1L,1H	49-51

\* Generator bracket stud shipped loose with manifold

\*\* When used to replace 8EL-6514 for service, complete set of 16 is to be used



# Lincoln and Lincoln Cosmopolitan

## CHASSIS PARTS CATALOGUE

PART NUMBER	CLAS	PART NAME	NO. REQ'D	MODEL	YEAR
<b>Intake Manifold—Continued</b>					
		8EL-9820 Tube (thermostat choke control)-inlet-5/16" O.D.	1	9L,9H	49
		0EL-9820 Tube (thermostat choke control)-inlet-5/16" O.D. pipe	1	0L,0H,1L,1H	50-51
		8CM-9877-C Elbow (thermostatic choke control tube)-inlet-90°-5/16" female and 21/64" male	1	9L,9H,0L,0H,1L,1H	49-51
		8CM-9884-C Elbow (thermostatic choke control tube)-outlet-90°-1/4" female and 21/64" male	1	9L,9H	49
		0EL-9888 Bushing (heat tube to intake manifold)	1	0L,0H,1L,1H	50-51
		8EL-9890-B Tube (thermostatic choke control heat)	1	9L,9H	49
		0EL-9890 Tube (thermostatic choke control heat)	1	0L,0H,1L,1H	50-51
8EL 6521		Gasket (intake manifold)-Steel and Asbestos	1	9L,9H,0L,0H,1L,1H	49-51
8EL 6524-A		Baffle assy (valve chamber oil)	1	9L,9H,0L,0H	49-50
8EL 6524-B		Baffle assy (valve chamber oil)	1	0L,0H,1L,1H	50-51
		355847-S Nut (spring)-3/3"-valve chamber baffle to block	2	9L,9H,0L,0H,1L,1H	49-51

## Oil Pump

8EL 6603-C		Body assy (oil pump)	1	9L,9H,0L,0H,1L,1H	49-51
56H 6606-A		Stud (oil pump idler)-1/2" O.D. x 2-11/16" long	1	9L,9H,0L,0H,1L,1H	49-51
8EL 6608-C		Shaft assy (oil pump)	1	9L,9H,0L,0H,1L,1H	49-51
8EL 6610-B		Gear (oil pump driven)-8 teeth-right hand helix	1	9L,9H,0L,0H,1L,1H	49-51
B 6612-A		Bushing (oil pump)-31/64" I.D. x 5/8" O.D. x 7/8" long	2	9L,9H,0L,0H,1L,1H	49-51
8EL 6615-B		Cover assy (oil pump screen)	1	9L,9H,0L,0H,1L,1H	49-51
8EL 6621-B		Pump assy (oil)-less cover and screen assy	1	9L,9H,0L,0H,1L,1H	49-51
		355411-S2 Screw & lockwasher assy (hex-hd)-5/16"-18 x 3/4"-oil pump to cylinder block	1	9L,9H,0L,0H,1L,1H	49-51
8EL 6622-B		Cover and screen assy (oil pump)	1	9L,9H,0L,0H,1L,1H	49-51
		24325-S8 Bolt (hex-hd)-1/4"-28 x 5/8"-oil pump screen to pump	4	9L,9H,0L,0H,1L,1H	49-51
		34805-S2 Lockwasher-1/4"	4	9L,9H,0L,0H,1L,1H	49-51
8BA 6623-A		Screen assy (oil pump)	1	9L,9H,0L,0H,1L,1H	49-51
8EL 6626		Gasket (oil pump flange)-Paper	1	9L,9H,0L,0H,1L,1H	49-51
8BA 6628-A		Spring (oil pump screen)-5-9/16" long	1	9L,9H,0L,0H,1L,1H	49-51
8EL 6637-A		Cover assy (oil pump)	1	9L,9H,0L,0H,1L,1H	49-51
		24309-S2 Bolt (hex-hd)-1/4"-28 x 1/2"-oil pump cover to body	6	9L,9H,0L,0H,1L,1H	49-51
		34805-S8 Lockwasher-1/4"	6	9L,9H,0L,0H,1L,1H	49-51
8EL 6643		Seal (oil pump body to cylinder block)-1-1/8" I.D. x 9/64" thick	2	9L,9H,0L,0H,1L,1H	49-51
8EL 6652		Gear (oil pump shaft)-12 teeth-left hand helix	1	9L,9H,0L,0H,1L,1H	49-51

# Lincoln and Lincoln Cosmopolitan

## CHASSIS PARTS CATALOGUE

### Oil Pump—Continued

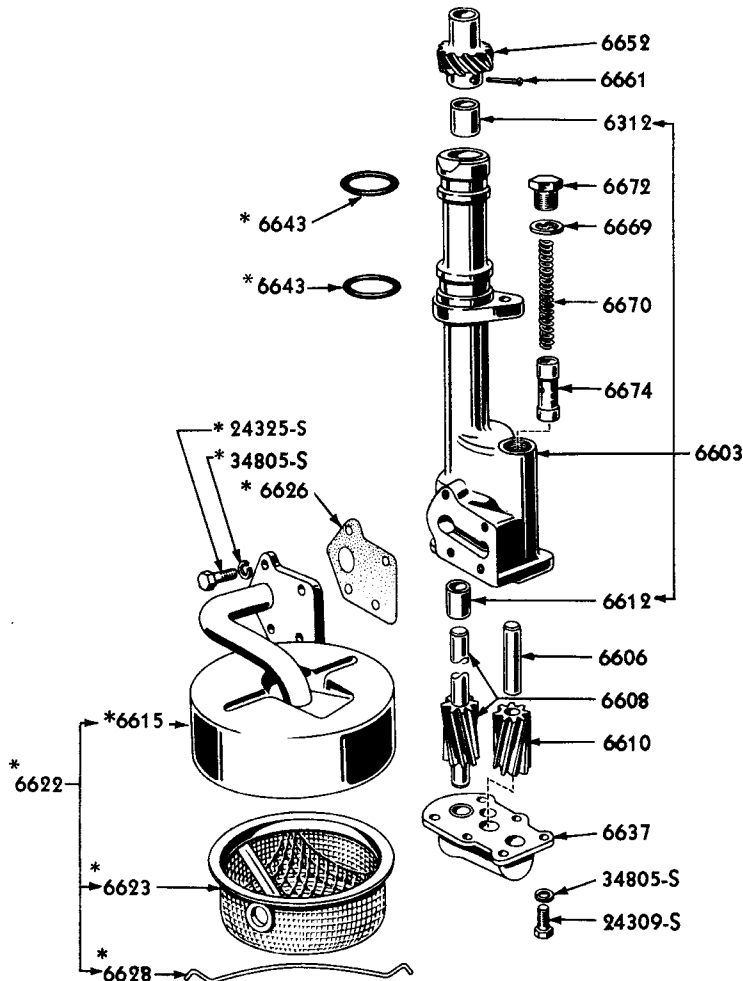

\*NOT INCLUDED IN 8EL-6621-B ASS'Y

PL-788

### OIL PUMP (8EL-6621-B)

Basic numbers only shown on illustration. Order by Part Numbers shown in list of parts.

PART NUMBER	QUANTITY	PART NAME	NO. REQ'D	MODEL	YEAR 19__
86H 6654		Spring (oil relief valve)-used with 353082-S	1	0L,0H,1L,1H	50-51
		353082-S Ball (cyl. block oil relief valve)-front-used with 86H-6654	1	0L,0H,1L,1H	50-51
8EL 6654		Spring (cylinder block front oil relief valve)-front-21/64" I.D. x 27/32" long-7 coils-replaced by (1) 86H-6654 & (1) 353082-S	1	9L,9H,0L,0H	49-50
18 6655-A		Gear assy (oil pump drive idler)-25 teeth-left hand helix	1	9L,9H,0L,0H,1L,1H	49-51
8BA 6656-B		Shaft (oil pump drive idler gear)-3/8"-16 tapped and not drilled thru	1	9L,9H,0L,0H	49-50
8EL 6656-B		Shaft (oil pump drive idler gear)-3/8"-16 tapped and drilled thru	1	9L,9H,0L,0H,1L,1H	49-51

# Lincoln and Lincoln Cosmopolitan

## CHASSIS PARTS CATALOGUE

### Oil Pump—Continued

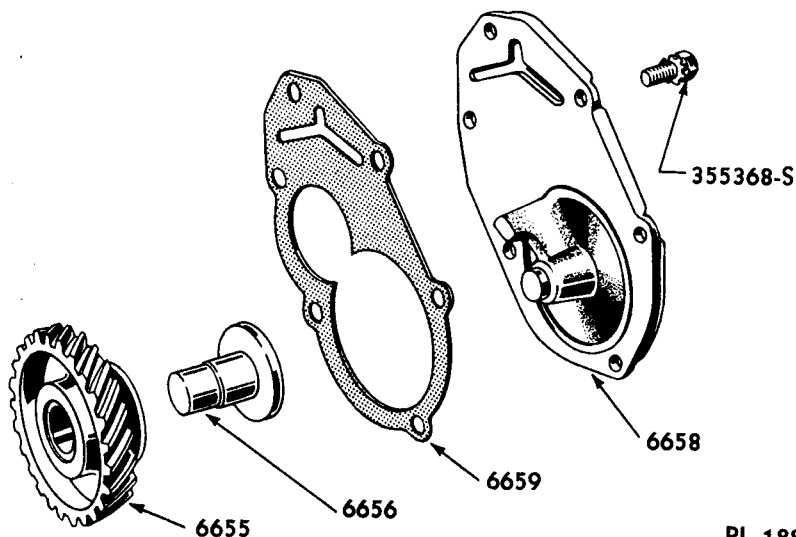

PL-188

### OIL PUMP DRIVE COVER AND RELATED PARTS

Basic numbers only shown on illustration. Order by Part Numbers shown in list of parts.

PART NUMBER	CLASS	PART NAME	NO. REQ'D	MODEL	YEAR
18 6657-A		Bushing (oil pump drive idler)	1	9L,9H,OL,OH,1L,1H	49-51
8EL 6658-B		Cover (oil pump drive)	1	9L,9H,OL,OH,1L,1H	49-51
		355368-S Screw and external tooth lockwasher assy (hex head)-5/16"-18 x 5/8"-oil pump drive cover to block	6	9L,9H,OL,OH,1L,1H	49-51
8EL 6659		Gasket (oil pump drive cover)	1	9L,9H,OL,OH,1L,1H	49-51
18 6661		Pin (oil pump shaft upper gear)-1/8" O.D. x 1-1/16" long	1	9L,9H,OL,OH,1L,1H	49-51
8EL 6663		Plunger (cylinder block oil relief valve)-front-21/32" overall length-replaced by (1) 86H-6654 and (1) 353082-S	1	9L,9H,OL,OH	49-50
		353082-S Ball (cylinder block oil relief valve)-used with 86H-6654	1	OL,OH,1L,1H	50-51
8EL 6666		Cap (hex-hd)-13/16"-16 x 45/64"-front oil relief valve	1	9L,9H,OL,OH,1L,1H	49-51
8EL 6669		Gasket (oil pump relief valve)-41/64" I.D. x 7/8" O.D. x 3/64" thick	1	9L,9H,OL,OH,1L,1H	49-51
8EL 6670-C		Spring (oil pump relief valve)-23/64" diameter x 2-51/64" overall length-18 coils	1	9L,9H,OL,OH,1L,1H	49-51
8EL 6672		Plug (oil pump relief valve)-5/8"-18 x 3/4"	1	9L,9H,OL,OH,1L,1H	49-51
8EL 6674-C		Plunger (oil pump relief valve)-9/16" O.D. x 1-1/2" long	1	9L,9H,OL,OH,1L,1H	49-51

# Lincoln and Lincoln Cosmopolitan

## CHASSIS PARTS CATALOGUE

### Oil Pan

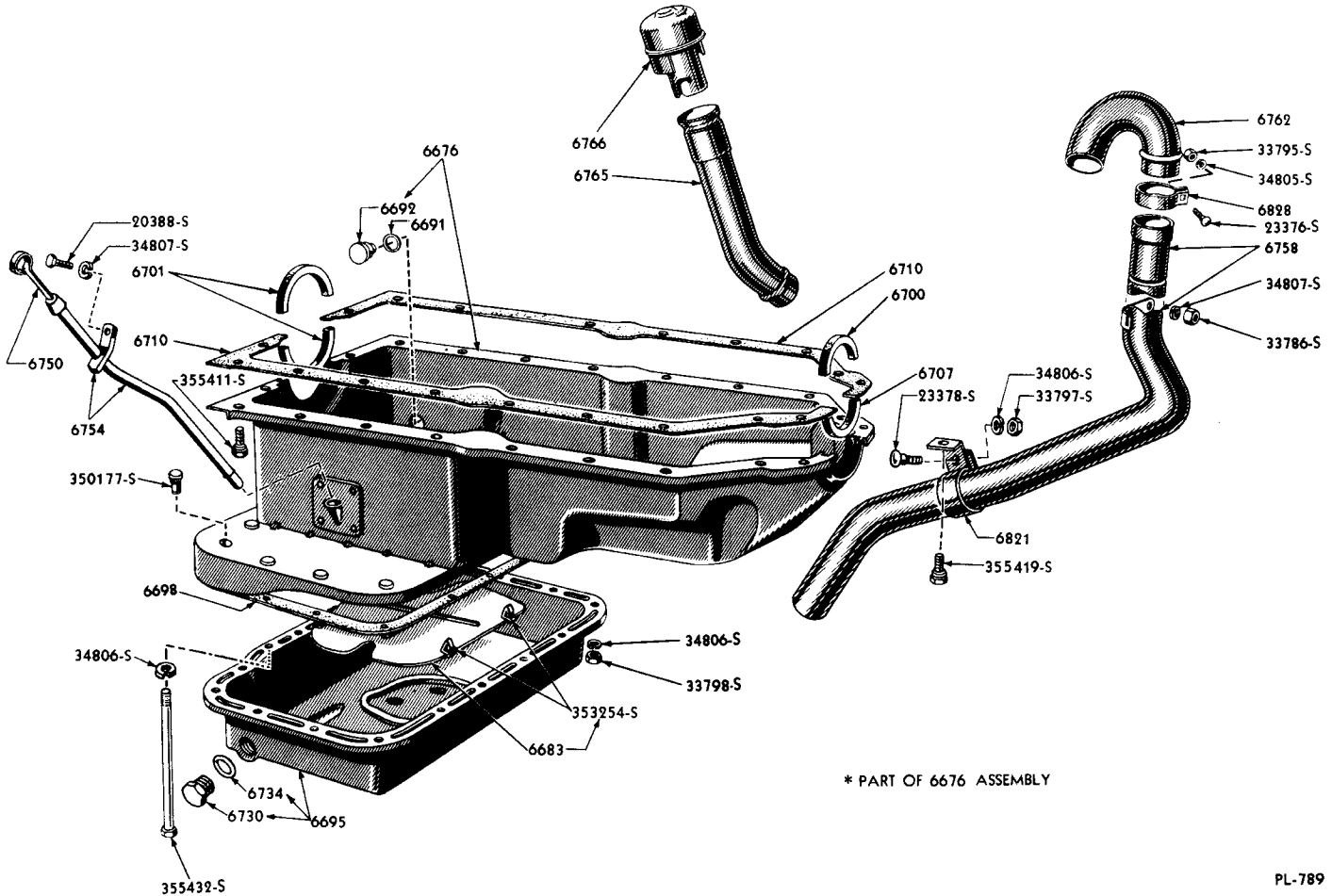

PL-789

### OIL PAN AND RELATED PARTS

Basic numbers only shown on illustration. Order by Part Numbers shown in list of parts.

PART NUMBER	UNDPFC	PART NAME	NO. REQ'D	MODEL	YEAR
8EL-6781		Kit (oil pan gasket)-consists of the following (1) 8EL-6701-B Packing (1) 8EL-6707 Packing (2) 8EL-6710 Gasket	1	9L,9H,0L,0H,1L,1H	49-51
8EL 6676-B		Body assy (oil pan)-does not include accelerator bellcrank inner bracket assy	1	9L,9H	49
8EL 6676-C		Body assy (oil pan)-includes accelerator bellcrank inner bracket assy	1	9L,9H,0L,0H,1L,1H	49-51
		355432-S Bolt (hex-hd)-5/16"-18 x 5-1/2"-oil pan body to engine	2	9L,9H,0L,0H,1L,1H	49-51
		355411-S2 Bolt and lockwasher assy (hex-hd)-5/16"-18 x 3/4"-oil pan body to cylinder block	18	9L,9H,0L,0H,1L,1H	49-51
		34806-S7 Lockwasher-5/16"-oil pan body to cylinder block	2	9L,9H,0L,0H,1L,1H	49-51
18 6677-B		Cover (starter pinion)	1	9L,9H	49

+ Used with HYDRA-MATIC transmission

++ Not used with HYDRA-MATIC transmission

# Lincoln and Lincoln Cosmopolitan

## CHASSIS PARTS CATALOGUE

PART NUMBER	PART NAME	NO. REQ'D	MODEL	YEAR
<b>Oil Pan—Continued</b>				
8EL 6683-C	Baffle assy (oil pan)	1	9L,9H,OL,OH,LL,1H	49-51
	353254-S Clip (speed)-oil pan baffle	4	9L,9H,OL,OH,LL,1H	49-51
11A 6691	Gasket (oil filter return pipe to oil pan)-59/64" O.D. x 13/16" I.D. x 1/32" thick	1	9L,9H,OL,OH,LL,1H	49-51
8EL 6692	Boss (oil filter return pipe to oil pan)	1	9L,9H,OL,OH,LL,1H	49-51
8EL 6695-B	Sump assy (oil pan)	1	9L,9H,OL,OH,LL,1H	49-51
	350177-S Bolt (serrated shoulder)-5/16"-24 x 9/16"-sump assy to oil pan	16	9L,9H,OL,OH,LL,1H	49-51
	34806-S7 Lockwasher-5/16"-oil sump to oil pan	16	9L,9H,OL,OH,LL,1H	49-51
	33798-S8 Nut (hex)-5/16"-24-sump to pan	16	9L,9H,OL,OH,LL,1H	49-51
	B-6730 Plug (oil pan drain)-3/4"-24	1	9L,9H,OL,OH,LL,1H	49-51
	B-6734 Gasket (oil pan drain plug)	1	9L,9H,OL,OH,LL,1H	49-51
8EL 6698	Gasket (oil pan body to sump)-Cork	1	9L,9H,OL,OH,LL,1H	49-51
8EL 6700	Packing (crankshaft front)-upper half-Asbestos	1	9L,9H,OL,OH,LL,1H	49-51
8EL 6701-B	Packing (crankshaft rear)-Asbestos	2	9L,9H,OL,OH,LL,1H	49-51

## Oil Filter

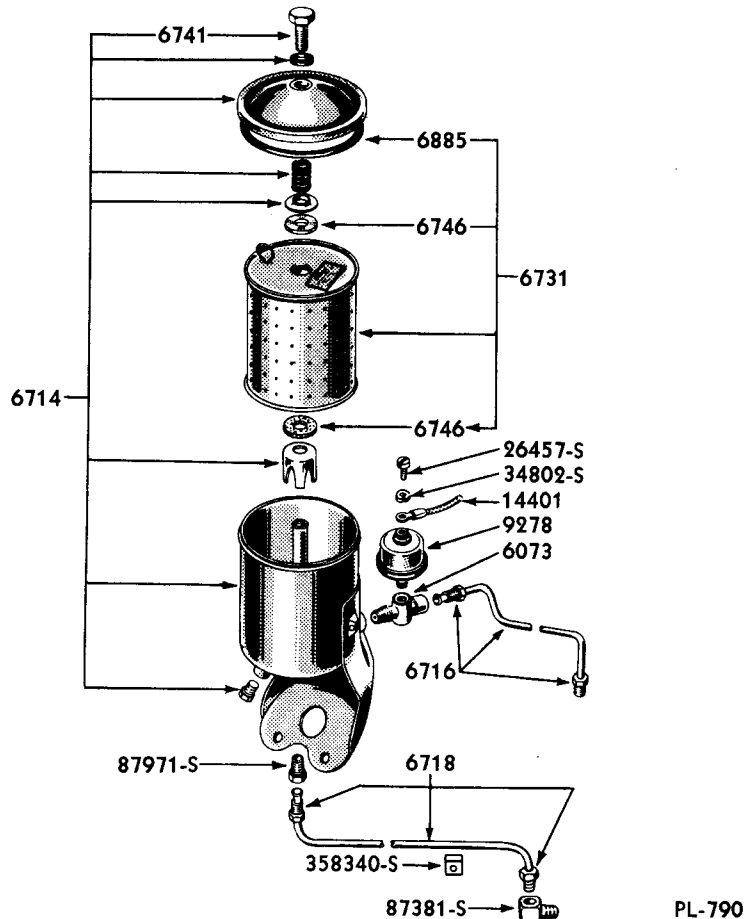

### OIL FILTER AND RELATED PARTS (8EL-6714-C)

Basic numbers only shown on illustration. Order by Part Numbers shown in list of parts.

# Lincoln and Lincoln Cosmopolitan

## CHASSIS PARTS CATALOGUE

PART NUMBER	PART NAME	NO. REQ'D	MODEL	YEAR 19__
<b>Oil Filter—Continued</b>				
8EL 6707	Packing (crankshaft front)-lower half-Asbestos	1	9L,9H,OL,OH,LL,LH	49-51
8EL 6710	NS Gasket (oil pan)-Cork-serviced in 8EL-6781 Kit	2	9L,9H,OL,OH,LL,LH	49-51
	8EL-6073-A Tee (oil pressure gauge)-for 1/4" flared tube and 1/4" pipe thread	1	9L,9H	49
	OEL-6073 Tee assy (oil pressure gauge relief valve)-with 1/4"-18 and 7/16"-14 tapped holes	1	OL,OH,LL,LH	50-51
8EL 6714-C	Filter assy (oil)	1	9L,9H	49
OEL 6714-A	Filter assy (oil)	1	OL,OH,LL,LH	50-51
	24387-S7 Bolt (hex head)-5/16"-24 x 1"-oil filter clamp to oil filter bracket	1	OL,OH,LL,LH	50-51
	24348-S8 Bolt (hex head)-3/8"-16 x 3/4"-oil filter to intake manifold	1	OL,OH,LL,LH	50-51
	24428-S8 Bolt (hex hd)-3/8"-16 x 1-1/4"-oil filler to intake manifold to cylinder	2	OL,OH,LL,LH	50-51
	34807-S2 Lockwasher-3/8"-to intake manifold and cylinder	3	OL,OH,LL,LH	50-51
	34806-S2 Lockwasher-5/16"-oil filter clamp to oil filter bracket	1	OL,OH,LL,LH	50-51
	33798-S8 Nut (hex)-5/16"-24-oil filter clamp to oil filter bracket	1	OL,OH,LL,LH	50-51
	351377-S7 Washer (flat)-3/8"-oil filter to intake manifold & cyl.	3	OL,OH,LL,LH	50-51
	01A-6741-B Screw (oil filter cover)	1	9L,9H,OL,OH,LL,LH	49-51
	01A-6746 Gasket (oil filter element)-Cork	1	9L,9H,OL,OH,LL,LH	49-51
8EL 6716	Tube assy (oil filter inlet)-1/4" O.D. x approx. 9/16" overall formed length-Steel	1	9L,9H	49
OEL 6716	Tube assy (oil filter inlet)-1/4" O.D. x approx. 17-1/8" overall formed length-Steel	1	OL,OH,LL,LH	50-51
	87971-S Connector-1/8"-pipe male thread and 7/16"-24 female thread-inlet connection to cylinder block	1	OL,OH,LL,LH	50-51
††8EL 6718-A	Tube assy (oil filter outlet)-1/4" O.D.-Steel	1	9L,9H	49
†8EL 6718-B	Tube assy (oil filter outlet)-1/4" O.D.-Steel	1	9L,9H	49
OEL 6718	Tube assy (oil filter outlet)-1/4" O.D.-Steel	1	OL,OH,LL,LH	50-51
	358340-S Clip (oil filter return line)-for .25" O.D. tube	1	9L,9H	49
	87971-S Connector-1/8"-pipe male thread and 7/16"-24 female thread-oil filter outlet connection and inlet to cylinder block	2	9L,9H	49
	87381-S Elbow-1/8"-taper thread and 7/16"-24 female thread-oil filter outlet tube to oil pan	1	9L,9H,OL,OH,LL,LH	49-51
	357908-S Elbow-1/8"-pipe thread and 7/16"-24 female thread-oil filter outlet connection	1	OL,OH,LL,LH	50-51

† Used with HYDRA-MATIC transmission

†† Not used with HYDRA-MATIC transmission

# Lincoln and Lincoln Cosmopolitan

## CHASSIS PARTS CATALOGUE

### Oil Filter—Continued

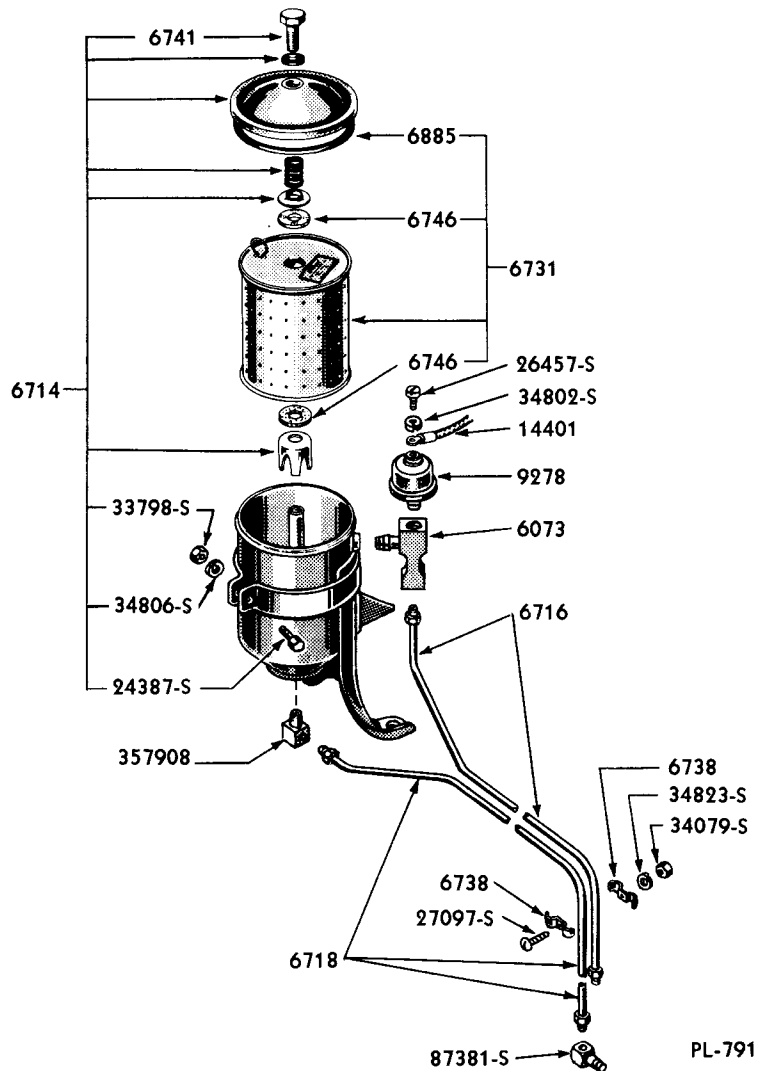

### OIL FILTER AND RELATED PARTS (OEL-6714-A)

Basic numbers only shown on illustration. Order by Part Numbers shown in list of parts.

PART NUMBER	CLAS	PART NAME	NO. REQ'D	MODEL	YEAR
B 6730		Plug (oil pan drain)-3/4"-24	1	9L, 9H, 0L, 0H, 1L, 1H	49-51
8CM 6731-A		Kit (oil filter element)-consists of the following (1) 7HA-6744-A Element (2) 01A-6746 Gasket (1) 01A-6885 Gasket	1	9L, 9H, 0L, 0H, 1L, 1H	49-51
B 6734		Gasket (oil pan drain plug)-Brass with Asbestos filler	1	9L, 9H, 0L, 0H, 1L, 1H	49-51
1CM 6734-A		Gasket (oil pan drain plug)-Nylon	1	1L, 1H	51

# Lincoln and Lincoln Cosmopolitan

## CHASSIS PARTS CATALOGUE

PART NUMBER	PART NAME	NO. REQ'D	MODEL	YEAR
<b>Oil Filter—Continued</b>				
OEL 6738	Clip (oil filter tube)-attaches oil filter inlet tube to oil filter outlet tube	2	OL,OH,LL,1H	50-51
	34823-S2 Lockwasher-No. 10	1	OL,OH,LL,1H	50-51
	34079-S7 Nut (hex)-No. 10-32-oil filter pipe clips to oil filter inlet and outlet pipes	1	OL,OH,LL,1H	50-51
	27097-S2 Screw (round head)-No. 10-32 x 5/8"-oil filter pipe clip to oil filter inlet and outlet pipes	1	OL,OH,LL,1H	50-51
OIA 6741-B	Screw (oil filter cover)	1	9L,9H,OL,OH,LL,1H	49-51
OIA 6746	Gasket (oil filter element)-1-1/4" O.D.-Cork	2	9L,9H,OL,OH,LL,1H	49-51

## Oil Filler and Crankcase Ventilation

8EL 6750-B	Indicator assy (oil level)	1	9L,9H	49
OEL 6750	Indicator assy (oil level)	1	OL,OH,LL,1H	50-51
8EL 6754-B	Tube assy (oil level indicator)-with indicator opening same diameter throughout tube	1	9L,9H	49
OEH 6754	Tube assy (oil level indicator)-with funnel type indicator opening and attaching clip with 2 holes crosswise with bracket	1	OH,1H	50-51
OEL 6754	Tube assy (oil level indicator)-with funnel type indicator opening and attaching clip with 2 holes lengthwise with bracket	1	OL,LL	50-51
	20388-S Bolt (hex hd)-3/8"-16 x 1"-tube brkt. to cyl. block	1or2	9L,9H,OL,OH,LL,1H	49-51
	34807-S Lockwasher-3/8"-tube brkt. to cyl. block	1or2	9L,9H,OL,OH,LL,1H	49-51
8EL 6758-B	Tube assy (crankcase ventilation)-lower	1	9L,9H,OL,OH,LL,1H	49-51
	20506-S7 Bolt (hex-hd)-3/8"-16 x 1-3/4"-vent tube bracket to block	1	9L,9H,OL,OH,LL,1H	49-51
	34807-S2 Lockwasher-3/8"-vent tube brkt. to block	1	9L,9H,OL,OH,LL,1H	49-51
	33786-S7 Nut (hex)-3/8"-24-vent tube bracket to block	1	9L,9H,OL,OH,LL,1H	49-51
	88512-S7 Stud-3/8"-24 and 3/8"-16 x 3"-vent tube bracket to block	1	9L,9H,OL,OH,LL,1H	49-51
8EL 6762-B	Elbow (crankcase ventilation)	1	9L,9H,OL,OH,LL,1H	49-51
86H 6765-B	Pipe (oil filler)	1	9L,9H,OL,OH,LL,1H	49-51
OEL 6766-A	Cap assy (breather cap)	1	9L,9H,OL,OH,LL,1H	49-51
8M 6780	Anti squeak (left & right hand shield assys)	4	9L,9H,OL,OH,LL,1H	49-51
8EL 6781	Kit (oil pan gasket)-consists of the following (1) 8EL-6701-B Packing (1) 8EL-6707 Packing (2) 8EL-6710 Gasket	1	9L,9H,OL,OH,LL,1H	49-51
8EL 6821-C	Bracket (crankcase ventilation tube)-lower	1	9L,9H,OL,OH,LL,1H	49-51
	23378-S7 Bolt (rd-hd)-5/16"-18 x 3/4"-crankcase vent tube lower bracket to crankcase	1	9L,9H,OL,OH,LL,1H	49-51



# Lincoln and Lincoln Cosmopolitan

## CHASSIS PARTS CATALOGUE

PART NUMBER	PART NAME	NO. REQ'D	MODEL	YEAR 19___
<b>Oil Filler and Crankcase Ventilation—Continued</b>				
	23409-S7 Bolt (hex hd)-5/16"-24 x 1"	1	9L,9H,OL,OH,1L,1H	49-51
	355411-S8 Bolt & washer (hex hd)-5/16"-18 x 3/4"-vent tube lower bracket to crankcase	1	9L,9H,OL,OH,1L,1H	49-51
	34806-S2 Lockwasher-5/16"-to attach brkt.	1	9L,9H,OL,OH,1L,1H	49-51
	33797-S7 Nut (hex)-5/16"-18-lower vent tube bracket	1	9L,9H,OL,OH,1L,1H	49-51
	33798-S8 Nut (hex)-5/16"-24	1	9L,9H,OL,OH,1L,1H	49-51
8EL 6828	Clamp (crankcase ventilation tube)-upper	1	9L,9H,OL,OH,1L,1H	49-51
	23376-S Bolt (carriage)-1/4"-20 x 3/4"-crankcase vent tube upper bracket	1	9L,9H,OL,OH,1L,1H	49-51
	34805-S8 Lockwasher-1/4"-upper vent tube clamp	1	9L,9H,OL,OH,1L,1H	49-51
	33795-S7 Nut (hex)-1/4"-20-upper vent tube clamp	1	9L,9H,OL,OH,1L,1H	49-51
8EL 6841	NS Cartridge assy (air filter ventilation tube)-not replaced	1	9L,9H,OL,OH,1L,1H	49-51
01A 6885	Gasket (oil filter cover)-4-5/16" I.D. x 4-23/32" O.D.	1	9L,9H,OL,OH,1L,1H	49-51

# Transmission Overdrive

	8H-4078	Control assy (trans. overdrive)- housing is 55-1/2" long	1	9H	49
	8L-4078	Control assy (trans. overdrive)- housing is 53" long	1	9L	49
	OM-4078	Cable assy (trans. o/drive)-approx. 46" long	1	OL,OH,LL,1H	50-51
	OL-4120	Bracket (O/Drive control to instr. panel)	1	OL,OH,LL,1H	50-51
	23901-84	Bolt (carriage)-1/4"-20 x 5/8"	1	OL,OH,LL,1H	50-51
	34805-82	Lockwasher-1/4"	1	OL,OH,LL,1H	50-51
	33795-87	Nut (hex)-1/4"-20	1	OL,OH,LL,1H	50-51
	8L-4296	Clip (overdrive control cable to gear shift housing)	1	9L,9H,OL,OH,LL,1H	49-51
	34941-87	Lockwasher-(external tooth)- 5/16"-overdrive control cable to gear shift housing	1	9L,9H,OL,OH,LL,1H	49-51
	20366-82	Screw (hex-hd)-5/16"-18 x 7/8"- overdrive control cable to gear shift housing	1	9L,9H,OL,OH,LL,1H	49-51
	21A-14605-A	Grommet (overdrive cable thru dash)  -Rubber-replaced by 352963-S	1	9L,9H,OL,OH,LL,1H	49-51
	352963-S	Grommet (overdrive cable thru dash)-Rubber	1	9L,9H,OL,OH,LL,1H	49-51
	34909-88	Lockwasher (internal tooth)- 1/2"-overdrive control to instrument panel	1	9L,9H,OL,OH,LL,1H	49-51
	351052-88	Nut (hex)-1/2"-20-overdrive control to instrument panel	1	9L,9H,OL,OH,LL,1H	49-51

# Lincoln and Lincoln Cosmopolitan

## CHASSIS PARTS CATALOGUE

### Transmission Overdrive—Continued

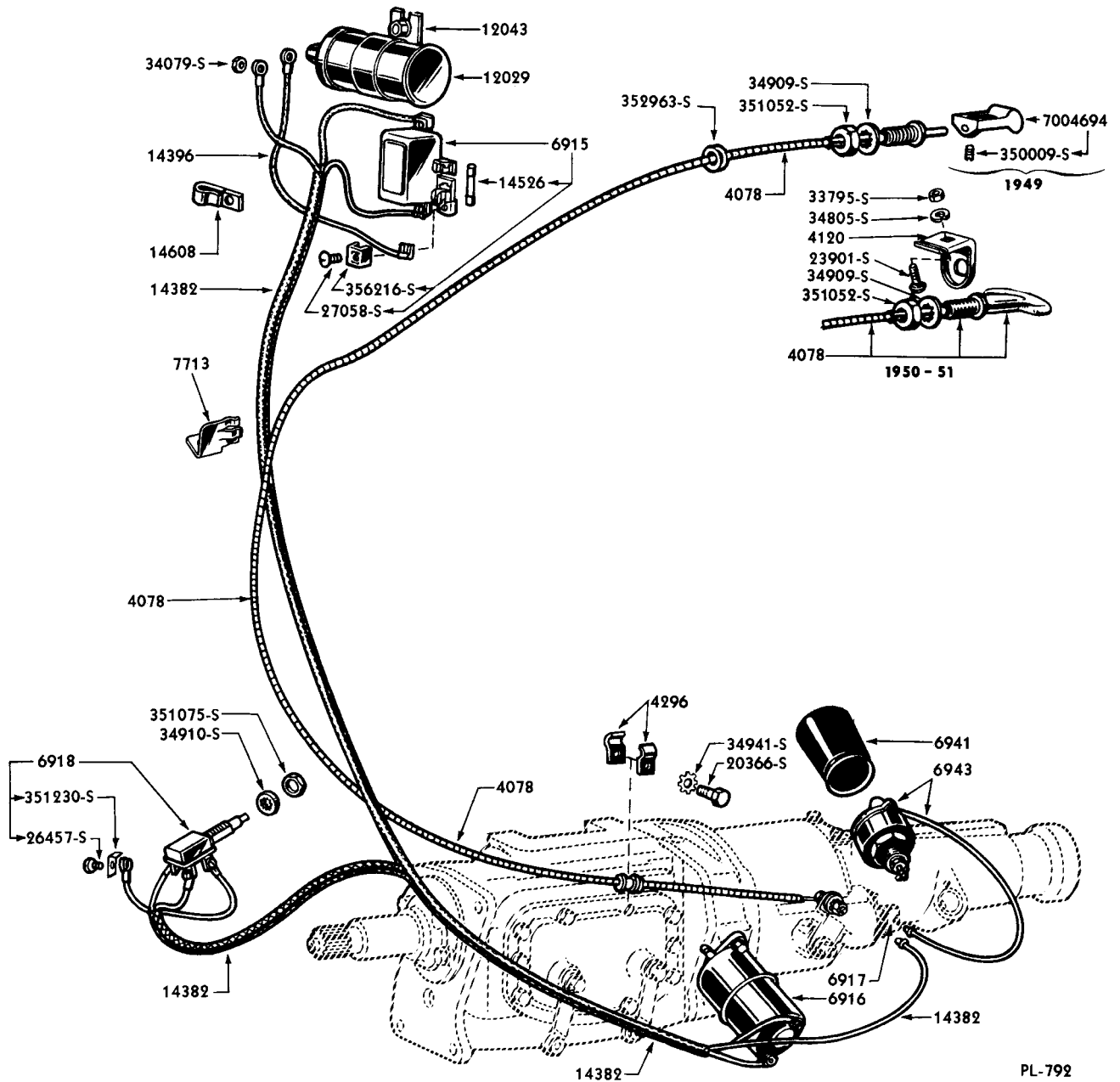

PL-792

## TRANSMISSION OVERDRIVE CONTROLS AND RELATED PARTS

Basic numbers only shown on illustration. Order by Part Numbers shown in list of parts.

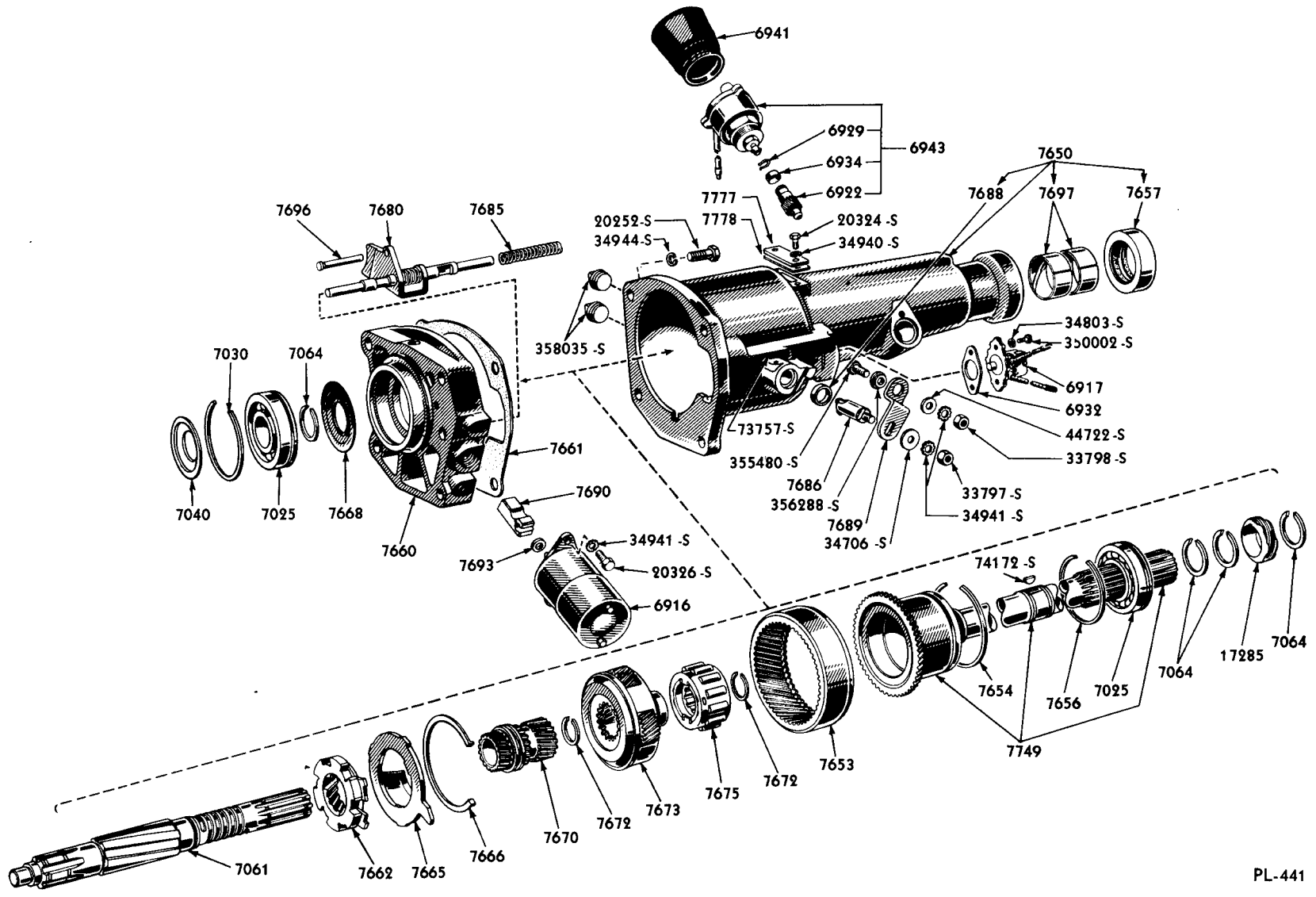

**TRANSMISSION OVERDRIVE**

Basic numbers only shown on illustration. Order by Part Numbers shown in list of parts.

PL-441

# Lincoln and Lincoln Cosmopolitan

## CHASSIS PARTS CATALOGUE

PART NUMBER	PART NAME	NO. REQ'D	MODEL	YEAR
<b>Transmission Overdrive—Continued</b>				
	8EL-7713 Clip (trans. overdrive control cable to engine)	1	9L,9H,0L,0H,1L,1H	49-51
	351025-S7 Nut (hex)-7/16"-20-clip to engine	1	9L,9H,0L,0H,1L,1H	49-51
	8L-7004694-B Tray assy (instrument control panel)	1	9L,9H	49
	350009-S8 Screw (headless set)-No. 8-32 x 5/16"-overdrive control cable to tray	1	9L,9H	49
8L 6903	Gear & case assy (transmission overdrive)	1	9L,9H,0L,0H,1L,1H	49-51
	358035-S Plug (extended head pipe)-1/2"-drain and fill	2	9L,9H,0L,0H,1L,1H	49-51
8M 6915	Relay assy (transmission overdrive)	1	9L,9H,0L,0H	49-50
1M 6915-A	Relay assy (transmission overdrive)	1	1L,1H	51
	31527-S7 Screw (hex washer head self tapping)-No. 14-10 x 1/2"-overdrive relay to dash panel	2	9L,9H,0L,0H,1L,1H	49-51
8M 6916-A	Solenoid assy (transmission overdrive gear shift)	1	9L,9H,0L,0H,1L,1H	49-51
	20326-S7 Bolt (hex-hd)-5/16"-18 x 5/8"-solenoid to overdrive	2	9L,9H,0L,0H,1L,1H	49-51
	34941-S7 Lockwasher (external tooth)-5/16"-solenoid to overdrive	2	9L,9H,0L,0H,1L,1H	49-51
8M 6917-A	Switch assy (overdrive rail)-without wiring	1	9L,9H	49
8M 6917-B	Switch assy (overdrive relay)-with two wires attached	1	9L,9H,0L,0H,1L,1H	49-51
	34803-S7 Lockwasher-No. 10-lockout switch to transmission hsg.	2	9L,9H,0L,0H,1L,1H	49-51
	350002-S8 Screw (slotted hex-hd)-No. 10-24 x 7/16"-lockout switch to trans. housing	2	9L,9H,0L,0H,1L,1H	49-51
8A 6918-A	Switch assy (trans. overdrive accel. kick down)-with (2) upper terminals located off angle with switch	1	9L,9H	49
8A 6918-B	Switch assy (trans. overdrive accel. kick down)-with (2) upper terminals located at right angle to switch	1	9L,9H,0L,0H,1L,1H	49-51
	351075-S Locknut-9/16"-kickdown switch to floor board	2	9L,9H,0L,0H,1L,1H	49-51
	34910-S2 Lockwasher-9/16"-kickdown switch to floor board	2	9L,9H,0L,0H,1L,1H	49-51
8M 6919	NS Switch assy (transmission overdrive governor)-replaced by 8M-6943	1	9L,9H	49
8M 6922	Gear (transmission overdrive governor driven)-18 teeth	1	9L,9H,0L,0H,1L,1H	49-51
16H 6929	Ring (transmission overdrive governor driven gear retaining)	1	9L,9H,0L,0H,1L,1H	49-51
16H 6930	Grommet (male clinch)-No. 5-used with trans. overdrive kick down switch	1	9L,9H,0L,0H,1L,1H	49-51
16H 6931	Grommet (female clinch)-No. 5-used with trans. overdrive kick down switch	1	9L,9H,0L,0H,1L,1H	49-51
56H 6932	Gasket (transmission overdrive control switch)	1	9L,9H,0L,0H,1L,1H	49-51

# Lincoln and Lincoln Cosmopolitan

## CHASSIS PARTS CATALOGUE

PART NUMBER	PART NAME	NO. REQ'D	MODEL	YEAR
<b>Transmission Overdrive—Continued</b>				
16H 6934	Sleeve (transmission governor gear pinion)	1	9L, 9H, 0L, 0H, 1L, 1H	49-51
8M 6941	Cover (transmission overdrive governor)-Rubber	1	9L, 9H, 0L, 0H, 1L, 1H	49-51
8M 6943	Governor and governor gear assy (trans. overdrive)	1	9L, 9H, 0L, 0H, 1L, 1H	49-51
	8A-7025 Bearing assy (trans. overdrive main shaft and ring gear assy ball)-1-3/8" I.D. x 2-53/64" O.D. x 21/32" wide	1	9L, 9H, 0L, 0H, 1L, 1H	49-51
	01A-7034 Vent assy (trans. overdrive housing assy)	1	9L, 9H, 0L, 0H, 1L, 1H	49-51
	8L-7061-B Shaft (trans. main)	1	9L, 9H, 0L, 0H, 1L, 1H	49-51
	8L-7064-A Snap ring (speedometer driving gear to trans. overdrive main shaft assy)-.086"/.088" thick	2	9L, 9H, 0L, 0H, 1L, 1H	49-51
	8L-7064-A Snap ring (trans. overdrive main shaft and ring assy bearing to shaft)-.086"/.088" thick	1	9L, 9H, 0L, 0H, 1L, 1H	49-51
	8L-7064-A Snap ring (trans. main shaft)-.086"/.088" thick	1	9L, 9H, 0L, 0H, 1L, 1H	49-51
	8L-7064-B Snap ring (trans. overdrive main shaft and ring assy bearing to shaft)-.089"/.091" thick	1	9L, 9H, 0L, 0H, 1L, 1H	49-51
	8L-7064-B Snap ring (trans. main shaft)-use on cars with trans. overdrive-.089"/.091" thick	1	9L, 9H, 0L, 0H, 1L, 1H	49-51
	8L-7064-C Snap ring (trans. overdrive main shaft and ring assy bearing to shaft)-.092"/.094" thick	1	9L, 9H, 0L, 0H, 1L, 1H	49-51
	8L-7064-C Snap ring (trans. main shaft)-use on cars with trans. overdrive-.092"/.094" thick	1	9L, 9H, 0L, 0H, 1L, 1H	49-51
	8L-7064-D Snap ring (trans. overdrive main shaft and ring assy bearing to shaft)-.095"/.094" thick	1	9L, 9H, 0L, 0H, 1L, 1H	49-51
	8L-7064-D Snap ring (trans. main shaft)-use on cars with trans. overdrive-.095"/.097" thick	1	9L, 9H, 0L, 0H, 1L, 1H	49-51
	8L-7650-B Housing assy (trans. overdrive)	1	9L, 9H, 0L, 0H, 1L, 1H	49-51
	20252-S2 Bolt (hex-hd)-1/2"-13 x 2-3/4"-overdrive housing assy to transmission	4	9L, 9H, 0L, 0H, 1L, 1H	49-51
	34944-S2 Lockwasher-1/2"-(external tooth)-overdrive housing assy to transmission	4	9L, 9H, 0L, 0H, 1L, 1H	49-51
NS	8L-7652 Shaft and ring gear assy (trans. overdrive main)-replaced by (1) 8A-7025, (1) 8L-7064-A, B or C, (2) 8L-7064-A, (1) 8L-7653, (1) 8L-7054-A, B or C, (1) 8L-7749, (1) 8L-17285, (1) 74172-S	1	9L, 9H, 0L, 0H, 1L, 1H	49-51
	8L-7653 Gear (trans. overdrive ring)-52 teeth-5-5/32" O.D.	1	9L, 9H, 0L, 0H, 1L, 1H	49-51

# Lincoln and Lincoln Cosmopolitan

## CHASSIS PARTS CATALOGUE

PART NUMBER	PART NAME	NO. REQ'D	MODEL	YEAR 19__
<b>Transmission Overdrive—Continued</b>				
8L-7654-A	Ring (trans. 0/Drive ring gear snap)-.054"/.056" thick	as reqd	9L, 9H, 0L, 0H, 1L, 1H	49-51
8L-7654-B	Ring (trans. 0/Drive ring gear snap)-.056"/.058" thick	as reqd	9L, 9H, 0L, 0H, 1L, 1H	49-51
8L-7654-C	Ring (trans. 0/Drive ring gear snap)-.058"/.060" thick	as reqd	9L, 9H, 0L, 0H, 1L, 1H	49-51
8M-7656	Snap ring (transmission overdrive main shaft bearing)-2-11/16" I.D. x 3-1/16" O.D. x .073" thick-open ends	1	9L, 9H, 0L, 0H, 1L, 1H	49-51
8L-7657-A	Seal assy (trans. main shaft oil)	1	9L, 9H, 0L, 0H, 1L, 1H	49-51
8L-7660	Adapter (transmission overdrive)	1	9L, 9H, 0L, 0H, 1L, 1H	49-51
8L-7661	Gasket (transmission overdrive housing adapter)	1	9L, 9H, 0L, 0H, 1L, 1H	49-51
8L-7662	Ring and gear plate assy (trans. overdrive balk)	1	9L, 9H, 0L, 0H, 1L, 1H	49-51
56H-7665	Plate and trough assy (cover)	1	9L, 9H, 0L, 0H, 1L, 1H	49-51
16H-7666-A	Snap ring (transmission overdrive cover plate)-.062" thick	1	9L, 9H, 0L, 0H, 1L, 1H	49-51
16H-7666-B	Snap ring (transmission overdrive cover plate)-.070" thick	1	9L, 9H, 0L, 0H, 1L, 1H	49-51
16H-7666-C	Snap ring (transmission overdrive cover plate)-.066" thick	1	9L, 9H, 0L, 0H, 1L, 1H	49-51
8L-7668	Baffle (trans. main shaft oil)	1	9L, 9H, 0L, 0H, 1L, 1H	49-51
8L-7670	Gear assy (trans. overdrive sun)	1	9L, 9H, 0L, 0H, 1L, 1H	49-51
8L-7672-A	Ring (trans. 0/Drive pinion cage to main shaft)-.062" thick	1	9L, 9H, 0L, 0H, 1L, 1H	49-51
8L-7672-B	Ring (trans. 0/Drive pinion cage to main shaft)-.068" thick	1	9L, 9H, 0L, 0H, 1L, 1H	49-51
8L-7672-C	Ring (trans. 0/Drive pinion cage to main shaft)-.074" thick	1	9L, 9H, 0L, 0H, 1L, 1H	49-51
8L-7673	Cage assy (trans. 0/Drive pinion)	1	9L, 9H, 0L, 0H, 1L, 1H	49-51
8L-7675	Cam, roller & cage assy (trans. overdrive free wheel)	1	9L, 9H, 0L, 0H, 1L, 1H	49-51
8L-7680	Fork and rail assy (transmission overdrive shift)	1	9L, 9H, 0L, 0H, 1L, 1H	49-51
16H-7685	Spring (trans. 0/Drive retractor)	1	9L, 9H, 0L, 0H, 1L, 1H	49-51
8L-7686	Shaft (trans. overdrive control)	1	9L, 9H, 0L, 0H, 1L, 1H	49-51
73757-S	Pin (taper)-No. 0 x 1-1/4"-overdrive control shaft to overdrive case	1	9L, 9H, 0L, 0H, 1L, 1H	49-51
56H-7688	Seal assy (shifter shaft oil)	1	9L, 9H, 0L, 0H, 1L, 1H	49-51
8M-7689	Lever (trans. overdrive control)	1	9L, 9H, 0L, 0H, 1L, 1H	49-51
355480-S8	Bolt (hex-hd)-5/16"-24 x 7/8"-overdrive control lever to overdrive control shaft	1	9L, 9H, 0L, 0H, 1L, 1H	49-51

# Lincoln and Lincoln Cosmopolitan

## CHASSIS PARTS CATALOGUE

PART NUMBER	PART NAME	NO. REQ'D	MODEL	YEAR 19__
<b>Transmission Overdrive—Continued</b>				
34941-S7	Lockwasher (external tooth)- 5/16"-overdrive control lever to overdrive control shaft	1	9L, 9H, 0L, 0H, 1L, 1H	49-51
33797-S7	Nut (hex)-5/16"-18 overdrive control lever to overdrive control shaft	1	9L, 9H, 0L, 0H, 1L, 1H	49-51
33798-S2	Nut (hex)-5/16"-24-overdrive control to overdrive control lever	1	9L, 9H, 0L, 0H, 1L, 1H	49-51
356288-S8	Spacer-overdrive control to overdrive control lever	1	9L, 9H, 0L, 0H, 1L, 1H	49-51
44722-S8	Washer (flat)-5/16"-overdrive control to overdrive control lever	1	9L, 9H, 0L, 0H, 1L, 1H	49-51
8L-7690	Pawl (trans. overdrive stationery gear)	1	9L, 9H, 0L, 0H, 1L, 1H	49-51
26H-7693	Seal (trans. overdrive pawl operating rod oil)	1	9L, 9H, 0L, 0H, 1L, 1H	49-51
8L-7696	Guide (trans. O/Drive shaft rail)	1	9L, 9H, 0L, 0H, 1L, 1H	49-51
8L-7697-B	Bearing (trans. main shaft)-rear	2	9L, 9H, 0L, 0H, 1L, 1H	49-51
8EL-7713	Clip (trans. O/Drive control cable support at engine)	1	9L, 9H, 0L, 0H, 1L, 1H	49-51
8L-7749	Shaft & ring assy (trans. overdrive main)	1	9L, 9H, 0L, 0H, 1L, 1H	49-51
8M-7777	Cover (trans. overdrive main shaft)	1	9L, 9H, 0L, 0H, 1L, 1H	49-51
24324-S7	Bolt (hex-hd)-1/4"-20 x 5/8"- main shaft cover	2	9L, 9H, 0L, 0H, 1L, 1H	49-51
34940-S7	Lockwasher (external tooth)- 1/4"-main shaft brg. cover	2	9L, 9H, 0L, 0H, 1L, 1H	49-51
8M-7778	Gasket (trans. O/Drive main shaft cover)	1	9L, 9H, 0L, 0H, 1L, 1H	49-51
8L-14381	Wiring assy (overdrive harness to to ignition coil)-3-1/2" long	1	9L	49
8H-14382	Wiring assy (overdrive solenoid to relay)	1	9H, 0H	49-50
8M-14382	Wiring assy (overdrive solenoid to relay)	1	9L, 0L	49-50
8L-14396	Wiring assy (ignition circuit to overdrive relay)-11-1/2" long	1	9L, 9H, 0L, 0H, 1L, 1H	49-51
353262-S	Clip (overdrive wiring to carburetor mounting screw)- 9/32" hole diameter 5/8" wide x 1-29/32" long	1	9L, 9H, 0L, 0H, 1L, 1H	49-51
353266-AS	Clip (overdrive wiring to floor pan)-9/32" hole diameter 5/8" wide x 2" long	3	9L, 9H	49
358122-S21	Clip (overdrive wiring to floor pan)-25/32" x 27/64" head size x 5/8" long	3	9L, 9H	49
8L-17285	Gear (speedometer driving)-7 teeth	1	9L, 9H, 0L, 0H, 1L, 1H	49-51
74172-S	Key (woodruff)-No. 3	1	9L, 9H, 0L, 0H, 1L, 1H	49-51



# Lincoln and Lincoln Cosmopolitan

## CHASSIS PARTS CATALOGUE

PART NUMBER	CHASSIS	PART NAME	NO. REQ'D	MODEL	YEAR
<b>Transmission</b>					
		8L-7650-A Extension, bearing and seal assy (trans.)-used on cars without Transmission Overdrive	1	9L,9H,OL,OH,LL,1H	49-51
		20132-S2 Bolt (hex-hd)-1/2"-13 x 1-1/4"-extension assy to trans. case	4	9L,9H,OL,OH,LL,1H	49-51
		34944-S2 Lockwasher (external tooth)-1/2"-extension, bearing and seal assy to transmission	4	9L,9H,OL,OH,LL,1H	49-51
		353064-S Plug (extended head pipe)-1/2" drain	1	9L,9H,OL,OH,LL,1H	49-51
		8L-7657-A Seal assy (trans. main shaft oil)	1	9L,9H,OL,OH,LL,1H	49-51
+8L 7003	NS	Transmission assy-identification serial plate prefixed L-49-replaced by OL-7003	1	9L,9H,OL,OH	49-50
+OL 7003		Transmission assy-identification serial plate prefixed L-50	1	OL,OH,LL,1H	50-51
+8L 7005		Case assy (transmission)-used with 8L-7003	1	9L,9H,OL,OH	49-50
+OL 7005		Case assy (transmission)-used with OL-7003	1	OL,OH,LL,1H	50-51
8L 7006-A		Case (transmission)	1	9L,9H,OL,OH,LL,1H	49-51
		24430-S8 Bolt (hex-hd)-7/16"-14 x 1-1/4"-trans. to flywheel housing	4	9L,9H,OL,OH,LL,1H	49-51
		34808-S8 Lockwasher-7/16"-transmission to flywheel housing	4	9L,9H,OL,OH,LL,1H	49-51
		353064-S Plug (extended head pipe)-1/2" drain and fill-replaces 358035-S	2	9L,9H,OL,OH,LL,1H	49-51
8EL 7009		Plate (engine rear)	1	9L,9H,OL,OH,LL,1H	49-51
		20376-S Bolt (hex head)-5/16"-18 x 15/16"-engine plate to cylinder block	4	9L,9H,OL,OH,LL,1H	49-51
		20378-S7 Bolt (hex head)-3/8"-16 x 15/16"-engine plate to flywheel housing	3	9L,9H,OL,OH,LL,1H	49-51
		24348-S8 Bolt (hex-hd)-3/8"-16 x 3/4"-engine plate to flywheel housing	2	9L,9H,OL,OH,LL,1H	49-51
		34807-S2 Lockwasher-3/8"-engine plate to flywheel housing	5	9L,9H,OL,OH,LL,1H	49-51
		34806-S2 Lockwasher-5/16"-engine plate to cylinder block	4	9L,9H,OL,OH,LL,1H	49-51
8L 7017		Gear (transmission main drive)	1	9L,9H,OL,OH,LL,1H	49-51
26H 7025		Bearing assy (transmission main drive gear)	1	9L,9H,OL,OH,LL,1H	49-51
26H 7025		Bearing assy (transmission main shaft)-rear	1	9L,9H,OL,OH,LL,1H	49-51
8A 7025		Bearing assy (trans. overdrive main shaft and ring gear assy)-ball	1	9L,9H,OL,OH,LL,1H	49-51
8L 7026		Snap ring (trans. main drive gear bearing retaining)-3-1/32" I.D. x 3-11/32" O.D. x 1/16" thick-open ends	1	9L,9H,OL,OH,LL,1H	49-51

+ Used with HYDRA-MATIC transmission

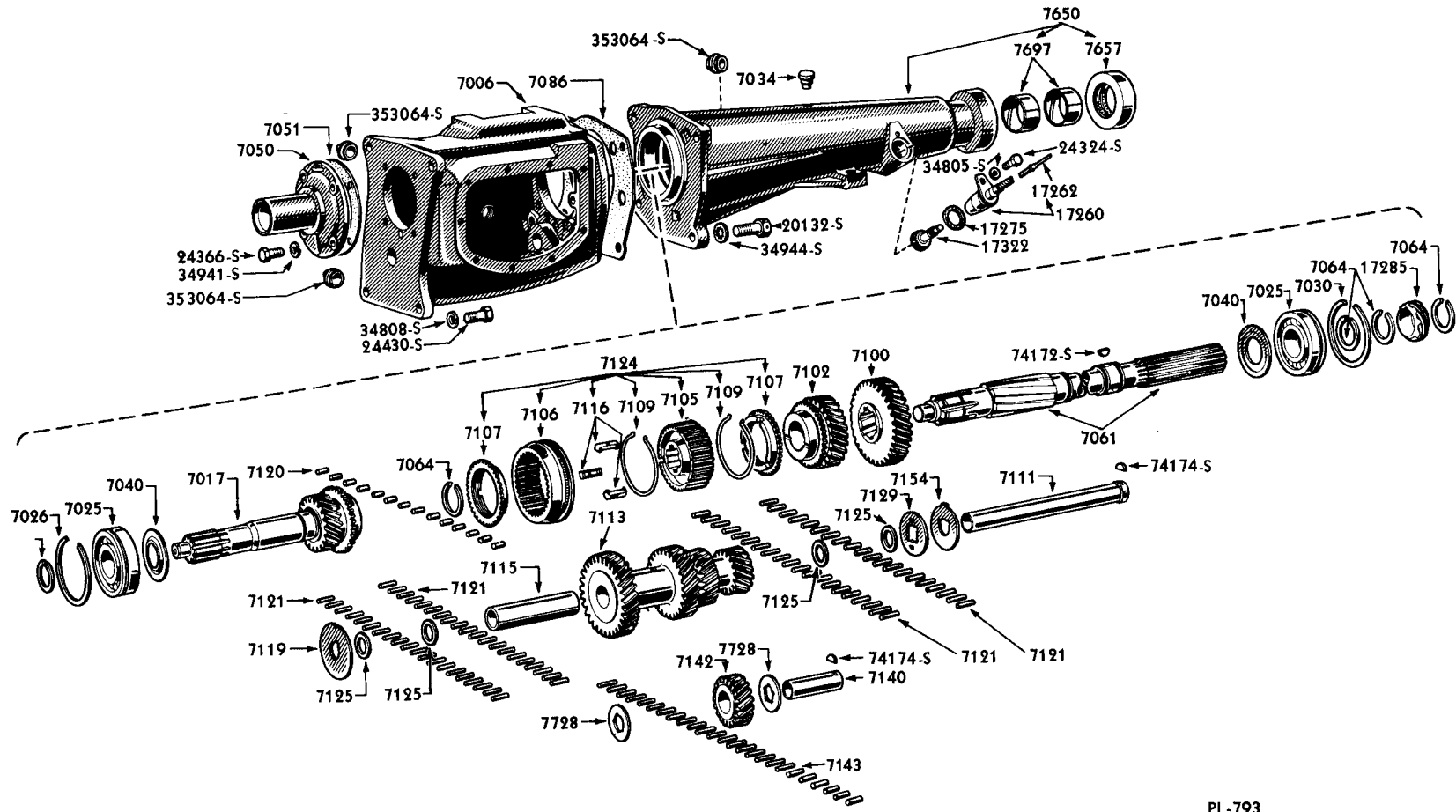

PL-793

**TRANSMISSION EXTENSION AND RELATED PARTS**

Basic numbers only shown on illustration. Order by Part Numbers shown in list of parts.

# Lincoln and Lincoln Cosmopolitan

## CHASSIS PARTS CATALOGUE

PART NUMBER	PART NAME	NO. REQ'D	MODEL	YEAR 19
<b>Transmission—Continued</b>				
8L 7030-A	Snap ring (trans. main shaft rear bearing)-.087"-.089" thick	1	9L,9H,OL,OH,LL,1H	49-51
8L 7030-B	Snap ring (trans. main shaft rear bearing)-.090"-.092" thick	1	9L,9H,OL,OH,LL,1H	49-51
8L 7030-C	Snap ring (trans. main shaft rear bearing)-.093"-.095" thick	1	9L,9H,OL,OH,LL,1H	49-51
8L 7030-D	Snap ring (trans. main shaft rear bearing)-.096"-.098" thick	1	9L,9H,OL,OH,LL,1H	49-51
8L 7030-E	Snap ring (trans. main shaft rear bearing)-.099"-.101" thick	1	9L,9H,OL,OH,LL,1H	49-51
01A 7034	Vent assy (trans. extension, bearing and seal assy)	1	9L,9H,OL,OH,LL,1H	49-51
01A 7034	Vent assy (transmission O/Drive housing assy)	1	9L,9H,OL,OH,LL,1H	49-51
01Y 7039	Kit (universal joint)-consists of the following (4) 01Y-707 <sup>4</sup> Bearing (1) 01Y-708 <sup>4</sup> Spider (4) 01Y-709 <sup>6</sup> Snap Ring	2	9L,9H,OL,OH,LL,1H	49-51
8L 7040	Baffle (transmission main drive gear oil)	2	9L,9H,OL,OH,LL,1H	49-51
8L 7050-A	NS Retainer (trans. main drive gear bearing)-has no oil return grooves-replaced by 8L-7050-B	1	9L,9H	49
8L 7050-B	Retainer (trans. main drive gear bearing)-has oil return grooves	1	9L,9H,OL,OH,LL,1H	49-51
	24366-S8 Bolt (hex-hd)-5/16"-18 x 7/8"-retainer to transmission case	4	9L,9H,OL,OH,LL,1H	49-51
	34941-S7 Lockwasher (external tooth)-5/16"-retainer to trans. case	4	9L,9H,OL,OH,LL,1H	49-51
8L 7051-A	Gasket (trans. main drive gear bearing retainer)-.010" thick	1	9L,9H,OL,OH,LL,1H	49-51
8L 7051-B	Gasket (trans. main drive gear bearing retainer)-.015" thick	1	9L,9H,OL,OH,LL,1H	49-51
8L 7051-C	Gasket (trans. main drive gear bearing retainer)-.020" thick	1	9L,9H,OL,OH,LL,1H	49-51
8L 7051-D	Gasket (trans. main drive gear bearing retainer)-.025" thick	1	9L,9H,OL,OH,LL,1H	49-51
78 7052	Seal (trans. main drive gear bearing oil)-use with 8L-7050-A	1	9L,9H,OL,OH,LL,1H	49-51
8L 7061-A	Shaft (trans. main)-27-3/64" long-used on cars w/o transmission overdrive	1	9L,9H,OL,OH,LL,1H	49-51
8L 7061-B	Shaft (trans. main)-14-39/64" long-used on cars with trans. overdrive	1	9L,9H,OL,OH,LL,1H	49-51
	8L-17285 Gear (speedometer driving)-7 teeth	1	9L,9H,OL,OH,LL,1H	49-51
	74172-S Key (woodruff)-No. 5-speedometer driving gear	1	9L,9H,OL,OH,LL,1H	49-51

# Lincoln and Lincoln Cosmopolitan

## CHASSIS PARTS CATALOGUE

PART NUMBER	QUANTITY	PART NAME	NO. REQ'D	MODEL	YEAR
					19__
<b>Transmission—Continued</b>					
8L 7064-A		Snap ring (speedometer driving gear to trans. main shaft)-.086"-.088" thick	2	9L,9H,0L,0H,1L,1H	49-51
8L 7064-A		Snap ring (trans. main shaft synchronizer)-.086"-.088" thick	1	9L,9H,0L,0H,1L,1H	49-51
8L 7064-A		Snap ring (trans. overdrive main shaft and ring assy bearing to shaft)-.086"-.088" thick	1	9L,9H,0L,0H,1L,1H	49-51
8L 7064-A		Snap ring (trans. main shaft)-.086"-.088" thick	1	9L,9H,0L,0H,1L,1H	49-51
8L 7064-A		Snap ring (trans. main drive gear bearing to shaft)-.086"-.088" thick	1	9L,9H,0L,0H,1L,1H	49-51
8L 7064-B		Snap ring (trans. overdrive main shaft and ring assy bearing to shaft)-.089"-.091" thick	1	9L,9H,0L,0H,1L,1H	49-51
8L 7064-B		Snap ring (trans. main shaft)-.089"-.091" thick	1	9L,9H,0L,0H,1L,1H	49-51
8L 7064-B		Snap ring (trans. main drive gear bearing to shaft)-.089"-.091" thick	1	9L,9H,0L,0H,1L,1H	49-51
8L 7064-C		Snap ring (trans. overdrive main shaft & ring assy bearing to shaft)-.092"-.094" thick	1	9L,9H,0L,0H,1L,1H	49-51
8L 7064-C		Snap ring (trans. main shaft)-.092"-.094" thick	1	9L,9H,0L,0H,1L,1H	49-51
8L 7064-C		Snap ring (trans. main drive gear bearing to shaft)-.092"-.094" thick	1	9L,9H,0L,0H,1L,1H	49-51
8L 7064-D		Snap ring (trans. overdrive main shaft & ring assy bearing to shaft)-.095"-.097" thick	1	9L,9H,0L,0H,1L,1H	49-51
8L 7064-D		Snap ring (trans. main shaft)-.095"-.097" thick	1	9L,9H,0L,0H,1L,1H	49-51
8L 7064-D		Snap ring (trans. main drive gear bearing to shaft)-.095"-.097" thick	1	9L,9H,0L,0H,1L,1H	49-51
01Y 7074	NS	Bearing assy (universal joint)-order 01Y-7039 Kit	8	9L,9H,0L,0H,1L,1H	49-51
01T 7078-A		Seal (universal joint grease)	8	9L,9H,0L,0H,1L,1H	49-51
01Y 7083		Ferrule (universal joint spider)	8	9L,9H,0L,0H,1L,1H	49-51
01Y 7084	NS	Spider assy (universal joint)-serviced in 01Y-7039 Kit	2	9L,9H,0L,0H,1L,1H	49-51
8L 7086-A		Gasket (transmission extension)	1	9L,9H,0L,0H,1L,1H	49-51
8L 7086-B		Gasket (transmission extension)	1	9L,9H,0L,0H,1L,1H	49-51
01Y 7096		Snap ring (universal joint spider brg. retaining)-1" x 1-3/16" O.D.-with curled open ends	6	9L,9H,0L,0H,1L,1H	49-51
8L 7100		Gear (transmission low and reverse sliding)	1	9L,9H,0L,0H,1L,1H	49-51
8L 7102		Gear & bushing assy (transmission intermediate)	1	9L,9H,0L,0H,1L,1H	49-51
8L 7105		Hub (transmission intermediate and high clutch)	1	9L,9H,0L,0H,1L,1H	49-51
8L 7106		Sleeve (transmission intermediate & high clutch hub)	1	9L,9H,0L,0H,1L,1H	49-51
8L 7107		Ring (transmission synchronizer blocking)	2	9L,9H,0L,0H,1L,1H	49-51
8L 7109		Spring (transmission intermediate & high clutch hub)	2	9L,9H,0L,0H,1L,1H	49-51
† Used with HYDRA-MATIC transmission					

# Lincoln and Lincoln Cosmopolitan

## CHASSIS PARTS CATALOGUE

PART NUMBER	CHASSIS	PART NAME	NO. REQ'D	MODEL	YEAR
<b>Transmission—Continued</b>					
8L 7111		Countershaft (transmission)	1	9L, 9H, 0L, 0H, 1L, 1H	49-51
		74172-S Key (woodruff)-No. 5-trans. countershaft retaining	1	9L, 9H, 0L, 0H, 1L, 1H	49-51
8L 7113		Gear (transmission countershaft)	1	9L, 9H, 0L, 0H, 1L, 1H	49-51
8L 7115		Spacer (transmission countershaft gear bearing)- .883" I.D. x 4.604" long	1	9L, 9H, 0L, 0H, 1L, 1H	49-51
8L 7116		Insert (transmission intermediate & high clutch hub)	3	9L, 9H, 0L, 0H, 1L, 1H	49-51
8L 7119		Washer (transmission countershaft gear thrust)-front -57/64" I.D. x 2-5/8" O.D. x 1/16" thick-Bronze	1	9L, 9H, 0L, 0H, 1L, 1H	49-51
70 7120		Bearing (transmission main shaft pilot)	14	9L, 9H, 0L, 0H, 1L, 1H	49-51
8L 7121		Bearing (transmission countershaft gear)-.158" dia. x .730" long	80	9L, 9H, 0L, 0H, 1L, 1H	49-51
8L 7124		Synchronizer assy (transmission)	1	9L, 9H, 0L, 0H, 1L, 1H	49-51
8L 7125		Spacer (transmission countershaft gear bearing)- .885" I.D. x 1.149" O.D. x .05" thick	4	9L, 9H, 0L, 0H, 1L, 1H	49-51
8L 7129		Washer (transmission countershaft gear thrust)-rear -57/64" I.D. x 2-1/8" O.D. x 1/16" thick-Steel	1	9L, 9H, 0L, 0H, 1L, 1H	49-51
8L 7140		Shaft (transmission reverse idler)	1	9L, 9H, 0L, 0H, 1L, 1H	49-51
		74174-S Key (woodruff)-No. 5-trans. reverse idler shaft retaining	1	9L, 9H, 0L, 0H, 1L, 1H	49-51
8L 7142		Gear (transmission reverse idler)	1	9L, 9H, 0L, 0H, 1L, 1H	49-51
8L 7143		Bearing (transmission reverse idler gear)	25	9L, 9H, 0L, 0H, 1L, 1H	49-51
8L 7153-A	NS	Kit (transmission and extension gasket)-replaced by 8L-7153-B	1	9L, 9H	49
8L 7153-B		Kit (transmission and overdrive gasket)-consists of the following (1) 56H-6932 Gasket (1) 8L-7051-A Gasket (1) 8L-7051-B Gasket (1) 8L-7051-C Gasket (1) 8L-7051-D Gasket (1) 8L-7086-A Gasket (1) 8L-7223 Gasket (1) 8L-7661 Gasket (1) 8M-7778 Gasket (1) 8M-17275 Gasket	1	9L, 9H, 0L, 0H, 1L, 1H	49-51
8L 7154-A		Washer (transmission countershaft gear thrust)-rear- 2-1/8" O.D. x 1/16" thick-with lug on O.D.	1	9L, 9H, 0L, 0H, 1L, 1H	49-51
8L 7160	NS	Snap ring (transmission main shaft)-replaced by 8L-7064-A	2	9L, 9H	49

# Lincoln and Lincoln Cosmopolitan

## CHASSIS PARTS CATALOGUE

### HYDRA-MATIC Transmission

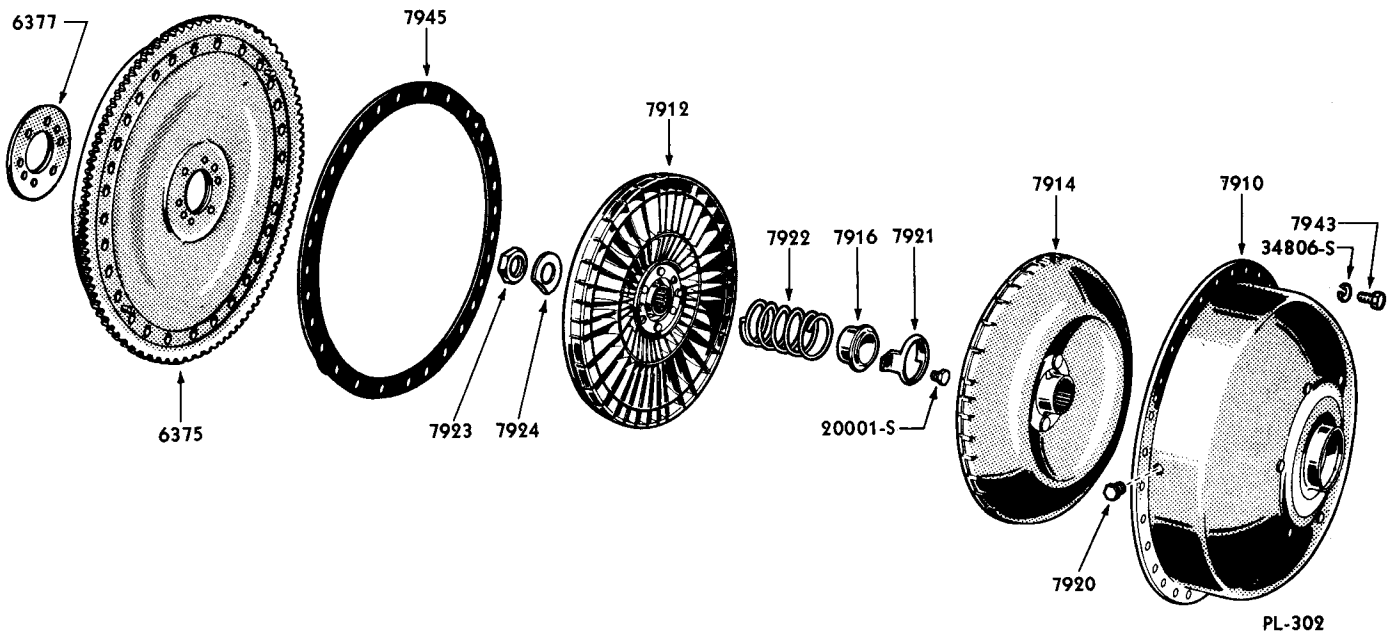

PL-302

### FLYWHEEL, TORUS MEMBERS AND COVER

Basic numbers only shown on illustration. Order by Part Numbers shown in list of parts.

PART NUMBER	CLASS	PART NAME	NO. REQ'D	MODEL	YEAR
		8L-19582-A Fluid for HYDRA-MATIC transmission-55 gallon drum container	as reqd	9L,9H,0L,0H,1L,1H	49-51
	NS	8L-19582-C Fluid for HYDRA-MATIC transmission-1 quart can container-order 8L-19582-D	as reqd	9L,9H,0L,0H,1L,1H	49-51
		8L-19582-D Fluid for HYDRA-MATIC transmission-case-consists of (24) 1 quart can containers	as reqd	9L,9H,0L,0H,1L,1H	49-51
		★8L-7325 Rod assy (manual shift)-18-45/64" overall length	1	9L,0L,1L	49-51
		★8H-7325-B Rod assy (manual shift)-17-27/32" overall length	1	9H,0H,1H	49-51
		★8L-14476 Wiring assy (starter switch to trans. lock switch)-50" long	1	9L,9H	49
		★0L-14476 Wiring assy (starter switch to trans. lock switch)-40" long	1	0L,0H,1L,1H	50-51

★ Used with but not a part of the HYDRA-MATIC transmission

# Lincoln and Lincoln Cosmopolitan

## CHASSIS PARTS CATALOGUE

PART NUMBER	PART NAME	NO. REQ'D	MODEL	YEAR
<b>HYDRA-MATIC Transmission—Continued</b>				
★8L-17260-B	Conduit and shaft assy (speedometer)-70-49/64" long	1	9L, 9H, 1H	49-51
★0L-17260-B	Conduit and shaft assy (speedometer)-64-15/16" long	1	0L, 1L	50-51
★8H-17260-B	Conduit and shaft assy (speedometer)-75-49/64" long	1	9H	49
★8L-17262-B	Shaft (speedometer)-71-1/8" long	1	9L, 9H, 1H	49-51
★8H-17262-B	Shaft (speedometer)-75-61/64" long	1	9H	49
★0L-17262-B	Shaft (speedometer)-65-3/16" long	1	0L, 1L	50-51
★8L-17269	Adapter (speedometer drive)	1	9L, 9H, 0L, 9H, 1L, 1H	49-51
★8L-17322-C	Gear assy (speedometer driven)-16 teeth-used with 8L-7003 and 0L-7003	1	9L, 9H, 0L, 9H, 1L, 1H	49-51
★1L-17322-A	Gear assy (speedometer driven)-19 teeth-used with 1L-7003-A	1	1L, 1H	51
NS 8L-7003	Transmission assy-identification serial plate prefixed L-49-replaced by 0L-7003	1	9L, 9H, 0L, 9H	49-50
0L-7003	Transmission assy-identification serial plate prefixed L-50	1	9L, 9H, 0L, 9H, 1L, 1H	49-51
1L-7003-A	Transmission assy-identification serial plate prefixed L-51-when used to replace 0L-7003 must also use (1) 1EL-6394-B and (1) 1L-17322-A	1	1L, 1H	51

### HYDRA-MATIC TRANSMISSION CHART

PART NUMBER	CLASS	PART NAME	HYDRA-MATIC TRANSMISSION					
			8L-7003	0L-7003	1L-7003-A			
			NUMBER REQUIRED					
8EL-6010-D		Block assy (cylinder)-includes 8EL-6394-C	●1	●1				
1EL-6010-A		Block assy (cylinder)-includes 1EL-6394-B			●1			
8EL-6375-C		Flywheel assy	●1	●1	●1			
8EL-6377		Gasket (flywheel to crankshaft)-2-7/16" I.D. x 4-51/64" O.D.	●1	●1	●1			
8EL-6379		Bolt (flywheel to crankshaft)-7/16"-20 x 13/16"	●6	●6	●6			
8EL-6394-C		Housing (flywheel)-with 4" diameter bore hole	●1	●1				
1EL-6394-B		Housing (flywheel)-with 4" diameter bore hole and 5-1/4" diameter counter bore hole			●1			
20550-S8		Bolt (hex-hd)-7/16"-14 x 2-3/4"-flywheel housing to cylinder block	●2	●2	●2			
24430-S8		Bolt (hex-hd)-7/16"-14 x 1-1/4"-flywheel housing to cylinder block	●4	●4	●4			
34808-S8		Lockwasher-7/16"-flywheel hsg. to cyl. block	●6	●6	●6			

★ Used with but not a part of the HYDRA-MATIC transmission

● Used with but not a part of basic number 7003 assembly

# Lincoln and Lincoln Cosmopolitan

## CHASSIS PARTS CATALOGUE

### HYDRA-MATIC Transmission—Continued

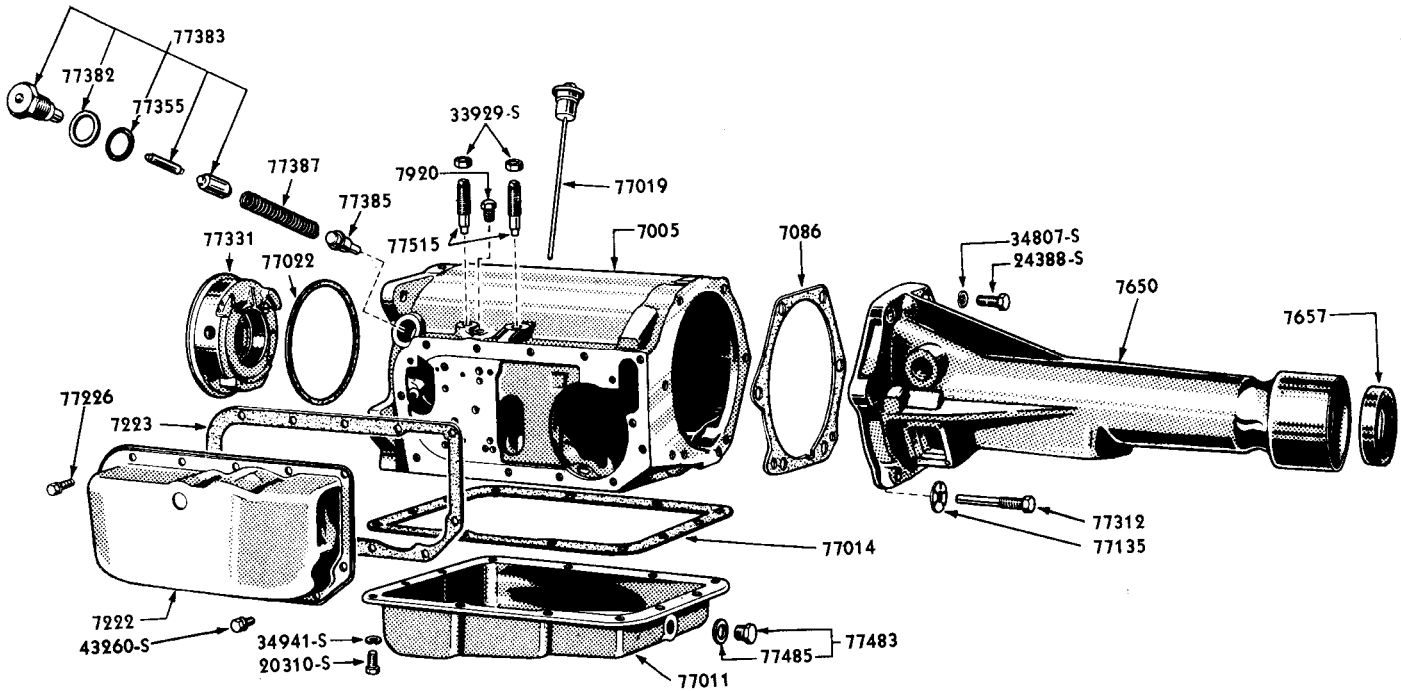

USED WITH 8L AND OL-7003

PL-812

### TRANSMISSION CASE AND RELATED PARTS

Basic numbers only shown on illustration. Order by Part Numbers shown in list of parts.

### HYDRA-MATIC TRANSMISSION CHART—CONTINUED

PART NUMBER	CLASS	PART NAME	HYDRA-MATIC TRANSMISSION				
			8L-7003	OL-7003	IL-7003-A		
			NUMBER REQUIRED				
8L-7005		Case Assy (transmission)	1				
OL 7005		Case Assy (transmission)		1			
1L-7006-A		Case Assy (transmission)			1		
1L-7030-A		Snap ring (trans. output shaft bearing retaining)- 2-37/64" O.D. x 2-17/64" I.D.			1		
1L-7070-A		Spacer (trans. output shaft rear bearing)- 1-9/16" O.D. x 1-25/64" I.D. x 1-5/16" thick			1		
8L-7086-B		Gasket (trans. extension)-Paper-6 holes	1	1			
1L-7086-A		Gasket (trans. extension)-8 holes			1		
8L-7222-B		Cover (trans. case)-side-lower corner bolt flange approximately 2-1/2" long	1	1			
1L-7222-A		Cover (trans. case)-side-lower corner bolt flange approximately 1-5/8" long			1		



# Lincoln and Lincoln Cosmopolitan

## CHASSIS PARTS CATALOGUE

### HYDRA-MATIC Transmission—Continued

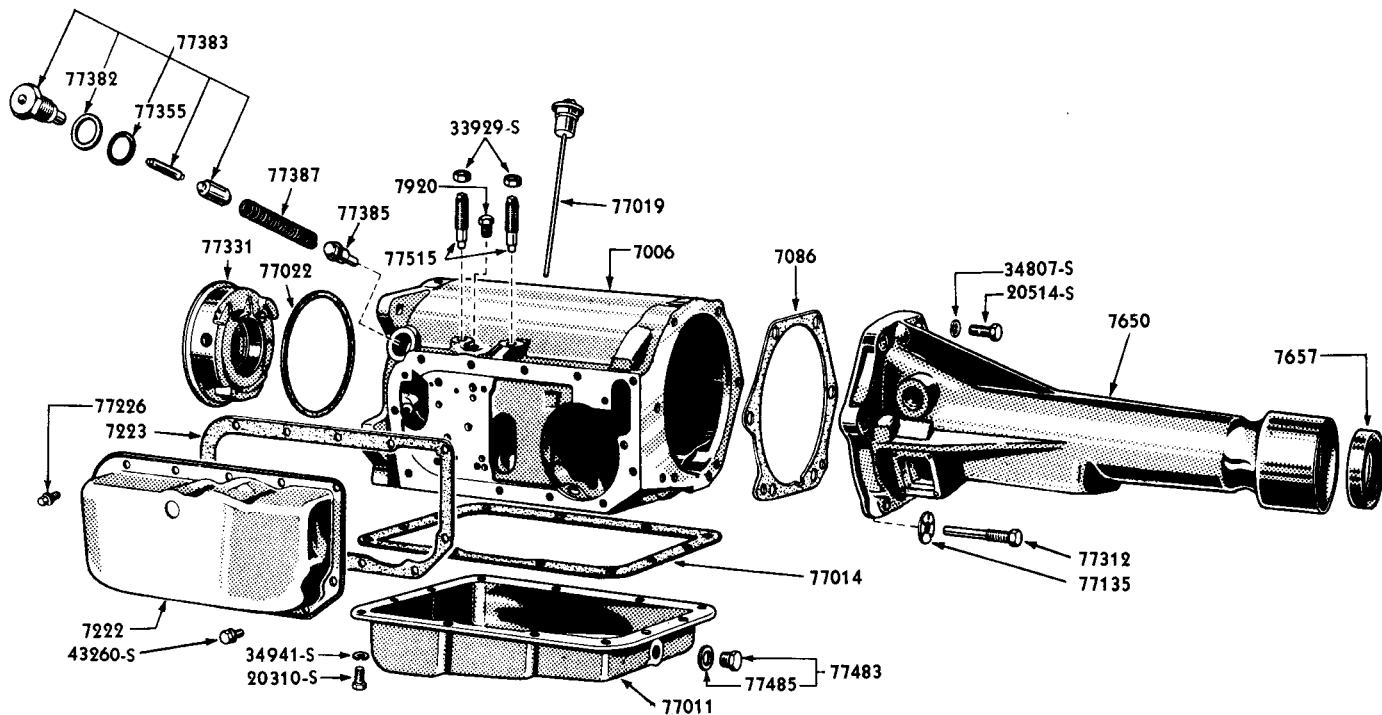

USED WITH IL-7003-A

PL-766

### TRANSMISSION CASE AND RELATED PARTS

Basic numbers only shown on illustration. Order by Part Numbers shown in list of parts.

### HYDRA-MATIC TRANSMISSION CHART—CONTINUED

PART NUMBER	CLASS	PART NAME	HYDRA-MATIC TRANSMISSION					
			8L-7003	OL-7003		IL-7003-A		
			NUMBER REQUIRED					
		8L-7223-B Gasket (transmission case side cover)	1	1				
		1L-7223-A Gasket (transmission case side cover)				1		
		8L-7285-C Lever (transmission outer shift)	1	1		1		
		50191-S Bolt (cross recessed fillister head)- 5/16"-24 x 1"-outer shift lever	1	1		1		
NS		8L-7622 Gasket (trans. to flywheel housing)-Paper- 6.38" O.D. x 4.02" I.D. x .015" thick-not repl.	●1	●1				
		8L-7650-C Extension assy (transmission)	1					
		OL-7650 Extension assy (trans.)-when used to replace 8L-7650-C it is also necessary to use OL-77133		1				
● Used with but not a part of basic number 7003 assembly								

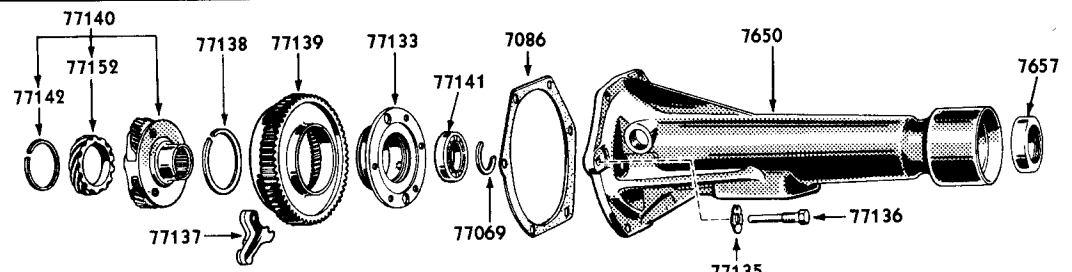
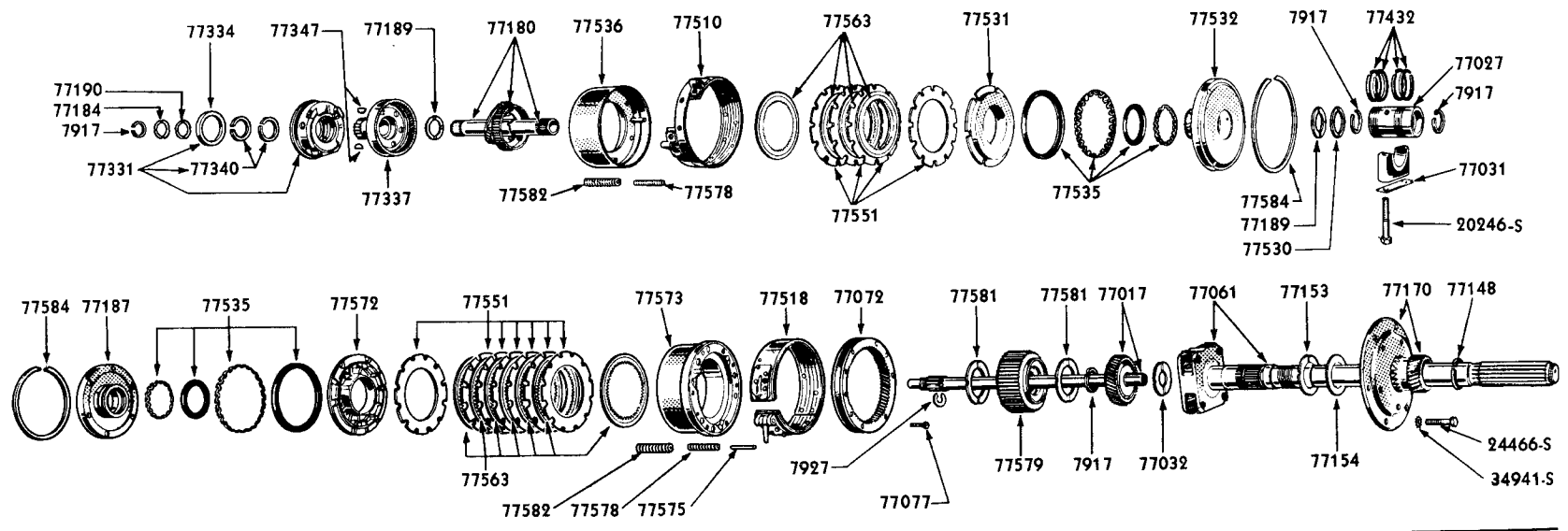

USED WITH 8L-7003 AND OL-7003

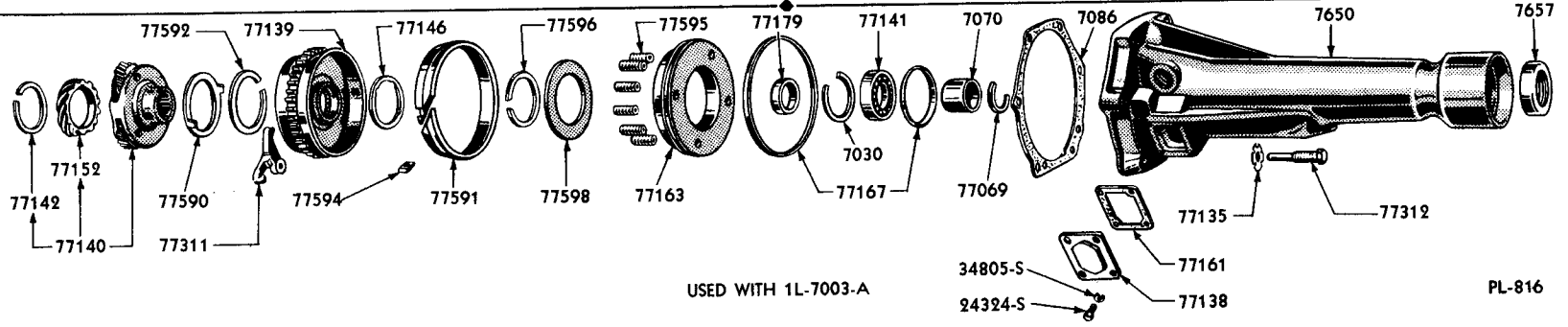

USED WITH 1L-7003-A

PL-816

**TRANSMISSION FRONT, CENTER AND REAR UNITS**

Basic numbers only shown on illustration. Order by Part Numbers shown in list of parts.

# Lincoln and Lincoln Cosmopolitan

## CHASSIS PARTS CATALOGUE

### HYDRA-MATIC Transmission—Continued

#### HYDRA-MATIC TRANSMISSION CHART—CONTINUED

PART NUMBER	CLASS	PART NAME	HYDRA-MATIC TRANSMISSION							
			8L-7003	OL-7003		IL-7003-A				
									NUMBER REQUIRED	
		1L-7650-A Extension assy (transmission)					1			
		20514-S7 Bolt (hex-hd)-3/8"-16 x 1-7/8"-extension assy to trans. case					5			
		24388-S8 Bolt (hex head)-3/8"-16 x 1"	5	5						
		34807-S2 Lockwasher-3/8"	5	5			5			
		8L-7657-B Oil seal assy (trans. ext. rear)-2.506" O.D. x 1.68" I.D. x 3/4" thick	1	1			1			
		8L-7692 Shield (transmission extension rear oil seal)-Steel	●1	●1			●1			
		8L-7910 Cover assy (transmission torus)	●1	●1			●1			
		8L-7912 Torus assy (transmission driven)	●1	●1			●1			
		8L-7914 Torus assy (transmission assy driving)	●1	●1			●1			
		8L-7916 Valve (transmission torus check)-1-5/32" I.D. of hole-used with 8L-7927	●1	●1						
		1L-7916-A Valve (transmission torus check)-1-3/32" I.D. of hole-used with 1L-7927-A	●1	●1			●1			
		8L-7917 Snap ring (torus retaining)	5	5			5			
		8L-7919 Lever (transmission throttle control outer)	●1	●1			●1			
		24385-S2 Bolt (hex-hd)-1/4"-28 x 1"-throttle control lever to trans. manual shaft	●1	●1			●1			
		8L-7920 Plug (hex head)-1/8" pipe-trans. case	1	1			1			
		8L-7920 Plug (hex head)-1/8" pipe-trans. torus cover	●1	●1			●1			
		8L-7920 Plug (hex head)-1/8" pipe-trans. front servo	1	1			1			
		8L-7921 Retainer (trans. torus check valve)	●1	●1			●1			
		20001-S7 Bolt (hex-hd)-1/4"-28 x 3/8"-transmission torus check valve retainer	●2	●2			●2			
		8L-7922 Spring (trans. torus check valve)-1-37/64" I.D. x 3-17/32" free length	●1	●1			●1			
		8L-7923 Nut (trans. main shaft)-hex-7/8"-16	●1	●1			●1			
		8L-7924 Washer (trans. main shaft nut lock)-optional with 1L-7924-A	●1	●1			●1			
		1L-7924-A Washer (trans. main shaft nut lock)-with inside flanged dia.-optional with 8L-7924	●1	●1			●1			
		8L-7927 Ring (trans. driven torus retainer)-53/64" opening-used with 8L-7916	●1	●1						
		1L-7927-A Snap ring (trans. driven torus)-3/16" opening-used with 1L-7916-A	●1	●1			●1			
		8L-7938 Bearing (trans. pilot)-Bronze-1-31/32" O.D. x 19/32" I.D. x 3/4" thick	1	1			1			
		8L-7942 Retainer (trans. pilot bearing)-Steel-1-37/64" O.D. x 19/32" I.D. x 13/64" thick	1	1			1			
		8L-7943 Bolt (torus cover to flywheel assy)-hex head-5/16"-24 x 45/64"	●30	●30			●30			
		34806-S7 Lockwasher-5/16"-torus cover to flywheel assy	●30	●30			●30			
		8L-7945 Gasket (flywheel to torus cover assy)	●1	●1			●1			
		8L-77008 Bolt (flywheel housing to trans.)-hex-hd-1/2"-13 x 1-1/2"	●4	●4			●4			
		34809-S8 Lockwasher-1/2"-flywheel housing to trans.	●4	●4			●4			

● Used with but not a part of basic number 7003 assembly

# Lincoln and Lincoln Cosmopolitan

## CHASSIS PARTS CATALOGUE

### HYDRA-MATIC Transmission—Continued

#### HYDRA-MATIC TRANSMISSION CHART—CONTINUED

PART NUMBER	CLASS	PART NAME	HYDRA-MATIC TRANSMISSION						
			8L-7003	OL-7003		1L-7003-A			
									NUMBER REQUIRED
		8L-77011 Pan assy (transmission oil)	1	1		1			
		20310-S8 Bolt (hex-hd)-5/16"-18 x 1/2"-oil pan to transmission case	12	12		12			
		34941-S7 Lockwasher (external tooth)-5/16"	12	12		12			
		8L-77014 Gasket (transmission oil pan)	1	1		1			
		8L-77016 Screen assy (trans. oil pump intake)	1	1		1			
		8L-77017 Gear and shaft assy (trans. main drive)	1	1		1			
		8L-77019 Indicator assy (trans. oil level)	1	1		1			
		8L-77020 Tube (trans. oil filler)	1	1		1			
		8L-77022 Gasket (trans. case front cover)	1	1		1			
		8L-77027 Sleeve assy (trans. oil supply to clutch)	1	1		1			
		8L-77031 Plate (trans. center bearing cap lock)	1	1		1			
		20246-S8 Bolt (hex-hd)-7/16"-14 x 2-1/2"-center bearing cap to case	2	2		2			
		8L-77032-A Washer (trans. main shaft thrust)-rear-.055"/.059" thick	as reqd	as reqd		as reqd			
		8L-77032-B Washer (trans. main shaft thrust)-rear-.063"/.067" thick	as reqd	as reqd		as reqd			
		8L-77032-C Washer (trans. main shaft thrust)-rear-.071"/.075" thick	as reqd	as reqd		as reqd			
		8L-77032-D Washer (trans. main shaft thrust)-rear-.079"/.083" thick	as reqd	as reqd		as reqd			
		8L-77032-E Washer (trans. main shaft thrust)-rear-.087"/.091" thick	as reqd	as reqd		as reqd			
		8L-77032-F Washer (trans. main shaft thrust)-rear-.095"/.099" thick	as reqd	as reqd		as reqd			
		8L-77032-G Washer (trans. main shaft thrust)-rear-.103"/.107" thick	as reqd	as reqd		as reqd			
		8L-77032-H Washer (trans. main shaft thrust)-rear-.111"/.115" thick	as reqd	as reqd		as reqd			
		8L-77061 Shaft assy (trans. output)-with snap ring groove at end	1						
		OL-77061 Shaft assy (trans. output)-with large chamfer at end of shaft also without snap ring groove	1	1					
		1L-77061-A Shaft assy (trans. output)-with approx. 45° spline end				1			
		8L-77069 Snap ring (trans. output shaft center bearing retainer)	1	1		1			
		8L-77072 Gear (rear internal)	1	1		1			
		1L-77072-A Gear (rear internal)				1			
		8L-77077 Screw (fillister-hd)-No. 10-24 x 1"-rear internal gear to rear drum	2	2		2			

# Lincoln and Lincoln Cosmopolitan

## CHASSIS PARTS CATALOGUE

### HYDRA-MATIC Transmission—Continued

#### HYDRA-MATIC TRANSMISSION CHART—CONTINUED

PART NUMBER	CLASS	PART NAME	HYDRA-MATIC TRANSMISSION						
			8L-7003	OL-7003		IL-7003-A			
									NUMBER REQUIRED
		8L-77126 Screw & washer assy (fillister-hd)-No. 10-24 x 1"-front valve body to inner valve body	3	3		3			
		8L-77126 Screw & washer assy (fillister-hd)-No. 10-24 x 1"-front valve body to cover plate				2			
		8L-77127 Screw & washer assy (fillister-hd)-No. 10-24 x 7/16"-front valve body cover plate	3	3		1			
		8L-77127 Screw & washer assy (fillister-hd)-No. 10-24 x 7/16"-outer valve body front cover	3	3		1			
		OL-77129 Piston (trans. reverse shifter block)-stamping	1	1					
		8L-77133 Support (trans. reverse internal gear)-with (5) bolt holes	1						
		OL-77133 Support (reverse internal gear)-with (4) bolt holes-when used to replace 8L-77133 it is also necessary to use OL-7650		1					
		24388-S8 Bolt (hex-hd)-3/8"-16 x 1"-attach reverse internal gear support to extension assy	5	5					
		8L-77134 Spring (trans. reverse anchor retractor)- 15/64" O.D. x 1-29/32" free length	1	1					
		8L-77135 Lock (trans. reverse anchor support bolt)	1	1		1			
		8L-77136 Bolt (hex head-dog point)-7/16"-20 x 2-9/32"- trans. reverse anchor support	1	1					
		8L-77137 Pawl (trans. reverse gear anchor)	1	1					
		8L-77138 Snap ring (trans. reverse internal gear retaining)	1	1					
		1L-77138-A Cover (trans. extension housing access)				1			
		24324-S7 Bolt (hex-hd)-1/4"-20 x 5/8"-cover to extension				4			
		34805-S8 Lockwasher-1/4"-cover to extension				4			
		8L-77139 Gear (trans. reverse internal)	1	1					
		1L-77139-A Gear assy (trans. reverse internal)				1			
		8L-77140 Carrier assy (trans. reverse planet)	1	1					
		1L-77140-A Carrier assy (trans. reverse planet)				1			
		8L-77141 Bearing assy (trans. output shaft)	1	1		1			
		8L-77142 Snap ring (trans. rear oil pump gear retaining)	1	1		1			
		8L-77144 Bearing (needle)-.0770"/.0772" diameter-.745" overall length-servo actuating lever pin	18	18		18			
		1L-77146-A Washer (trans. reverse internal gear thrust)- 3-1/4" O.D. x 2-9/16" I.D. x 3/32" thick				1			
		8L-77148 Snap ring (trans. reverse planet carrier retaining)-1.322"/1.342" I.D. x 1.572"/1.592" O.D. x .092"/.094" thick	1	1		1			
		8L-77152 Gear (trans. rear oil pump drive)	1	1		1			
		353080-S Ball-3/16" dia.-pump driver gear	1	1		1			

# Lincoln and Lincoln Cosmopolitan

## CHASSIS PARTS CATALOGUE

### HYDRA-MATIC Transmission—Continued

#### HYDRA-MATIC TRANSMISSION CHART—CONTINUED

PART NUMBER	CLASS	PART NAME	HYDRA-MATIC TRANSMISSION						
			8L-7003	OL-7003		IL-7003-A			
									NUMBER REQUIRED
		8L-77153 Washer (trans. reverse sun gear thrust)-Bronze-1-11/16" I.D. x 2-19/32" O.D. x .087"/.091" thick	1	1		1			
		8L-77154 Washer (trans. reverse sun gear backing thrust)-Steel-1-1/2" I.D. x 2-7/16" O.D. x .049"/.052" thick	1	1		1			
		1L-77155-A Spring (trans. reverse blocker piston)-5/16" O.D. x approx. 15/16" free length				1			
		8L-77156 Washer (flat)-3/8"-reverse internal gear support bolt	5						
		1L-77161-A Gasket (trans. extension housing access cover)				1			
		1L-77163-A Piston (trans. reverse)				1			
		1L-77164-A Pin (trans. reverse blocker piston stop)-1/8" diameter x 1-5/16" long				1			
	NS	1L-77167-A Seal (trans. reverse clutch piston)-outer-serviced in HBK-77167-A Kit				1			
		HBK-77167-A Kit (trans. reverse clutch piston seals)-consists of the following (1) 1L-77167-A Seal-outer (1) 1L-77174-A Seal-inner				1			
		8L-77170 Gear and flange assy (trans. reverse sun)	1	1		1			
		24466-S7 Bolt (hex-hd)-5/16"-18 x 1-1/2"-reverse drive flange to trans. rear drum & pin assy	6	6		6			
		34941-S7 Lockwasher (external tooth)-5/16"-reverse drive flange to trans. rear drum and pin assy	6	6		6			
	NS	1L-77174-A Seal (trans. reverse clutch piston)-inner-serviced in HBK-77167-A Kit				1			
		1L-77179-A Spacer (trans. reverse planet carrier)-1-11/16" O.D. x 1-25/64" I.D. x 23/64" thick				1			
		8L-77180 Carrier assy (trans. front planet)-complete	1						
		OL-77180 Carrier assy (trans. front planet)-complete	1	1		1			
		8L-77184 Washer (trans. front planetary assy front backing) Steel-1.340"/1.350" I.D. x 1.812"/1.822" O.D. x .088"/.092" thick	1	1		1			
		8L-77187 Drum assy (trans. rear clutch)	1						
		1L-77187-A Drum assy (trans. rear clutch)	1	1		1			
		8L-77189 Washer (trans. front clutch drum rear thrust)-Bronze-Grooved-1.377"/1.384" I.D. x 1.910"/1.917" O.D. x .087"/.091" thick	2	2		2			
		8L-77190 Washer (trans. front planetary assy front thrust)-Bronze-1-13/32" I.D. x 1-53/64" O.D. x .087"/.091" thick	1	1		1			

# Lincoln and Lincoln Cosmopolitan

## CHASSIS PARTS CATALOGUE

### HYDRA-MATIC Transmission—Continued

#### HYDRA-MATIC TRANSMISSION CHART—CONTINUED

PART NUMBER	CLASS	PART NAME	HYDRA-MATIC TRANSMISSION					
			8L-7003	OL-7003	IL-7003-A			
						NUMBER REQUIRED		
0L-77201		Valve assy (trans. oil control)-has end mill cut at corners of front valve body	1	1				
1L-77201-A		Valve assy (trans. oil control)			1			
34940-S2		Lockwasher (external tooth)-1/4"-control valve assy to transmission case	4	4	4			
8L-77211		Kit (trans. throttle shaft repair)-consists of the following (1) 72187-S7 Manual control shaft pin (1) 8L-77223 Throttle shaft seal (1) 351543-S Throttle shaft flat washer	1	1	1			
8L-77226		Bolt and washer assy (hex)-1/4"-20 x 1/2"-trans. side cover to case	5	5	5			
43260-S8		Screw & washer assy (hex)-1/4"-20 x 1/2"-trans. side cover to case	7	7	7			
8L-77231		Valve (trans. fourth to third speed down shift)	1	1	1			
8L-77232		Retainer (trans. fourth to third speed down shift valve)-with 7/16" inside loop diameter	1	1				
1L-77232-A		Retainer (trans. fourth to third speed down shift valve)-with 17/32" inside loop diameter	1	1	1			
8L-77234		Lever assy (trans. inside detent control)	1	1				
1L-77234-A		Lever assy (trans. inside detent control)			1			
8L-77284		Lever (trans. inside throttle valve control)	1	1	1			
72187-S7		Pin (grooved)-1/16" x 1/2"-throttle valve control lever	1	1	1			
351543-S		Washer (flat)-5/16"-to remove throttle shaft end play	as reqd	as reqd	as reqd			
1L-77285-A		Retainer assy (trans. detent plunger)			1			
8L-77291		Shim (trans. reverse shifter bracket)-Steel-.006"/.008" thick	1to6	1to6				
8L-77294		Piston (trans. reverse shifter blocker)-solid piece	1					
1L-77294-A		Piston (trans. reverse shifter blocker)			1			
8L-77295		Bracket and crank assy (trans. reverse shifter)	1					
OL-77295		Bracket and crank assy (trans. reverse shifter)	1	1				
1L-77295-A		Bracket and crank assy (trans. reverse shifter)			1			
352794-S		Bolt (hex-hd)-5/16"-18 x 2-1/16"	2	2	2			
34806-S2		Lockwasher-5/16"	2	2	2			
8L-77299		Roller (trans. reverse shifter crank)-5/16" I.D. x 3/4" O.D. x 1/4" thick	1	1	1			
1L-77311-A		Pawl (transmission parking)			1			
1L-77312-A		Bolt (hex-hd-dog point)-7/16"-20 x 2-61/64"-transmission parking pawl support			1			





# Lincoln and Lincoln Cosmopolitan

## CHASSIS PARTS CATALOGUE

### HYDRA-MATIC Transmission—Continued

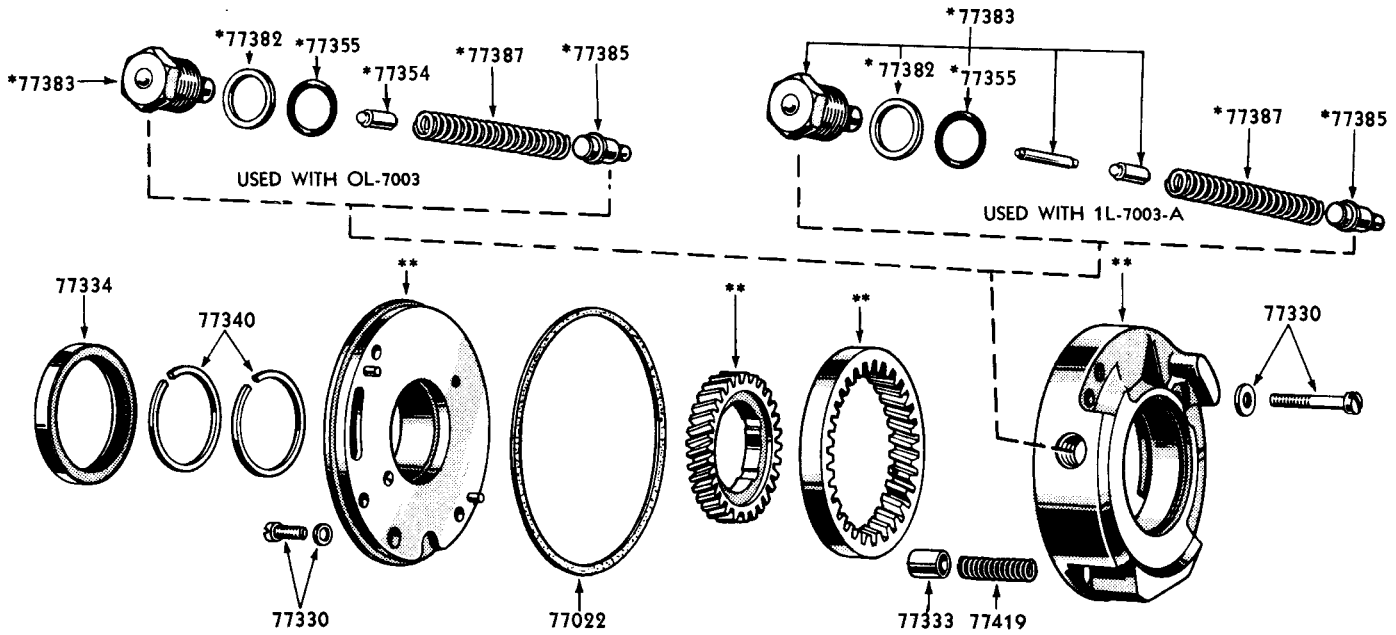

\*NOT INCLUDED IN BASIC NO. 77331 ASSEMBLY

\*\*SERVICED IN BASIC NO. 77331 ASSEMBLY.

PL-656

### TRANSMISSION FRONT OIL PUMP ASSY

Basic numbers only shown on illustration. Order by Part Numbers shown in list of parts.

### HYDRA-MATIC TRANSMISSION CHART—CONTINUED

PART NUMBER	CLASS	PART NAME	HYDRA-MATIC TRANSMISSION					
			8L-7003	OL-7003	IL-7003-A			
			NUMBER REQUIRED					
8L-77321		Pipe Assy (transmission front oil pump inlet)	1	1	1			
24324-37		Bolt (hex-hd)-1/4"-20 x 5/8"-intake pipe to front pump	2	2	2			
1L-77325-B		Spring (trans. parking blocker piston)-11/32" O.D. -approx. 1-1/32" free length			1			
1L-77327-B		Stop (transmission parking blocker piston spring)			1			
1L-77328-A		Piston (trans. parking blocker)-11/16" O.D. x 13/16" long			1			

# Lincoln and Lincoln Cosmopolitan

## CHASSIS PARTS CATALOGUE

### HYDRA-MATIC Transmission—Continued

#### HYDRA-MATIC TRANSMISSION CHART—CONTINUED

PART NUMBER	CLASS	PART NAME	HYDRA-MATIC TRANSMISSION						
			8L-7003	OL-7003		1L-7003-A			
			NUMBER REQUIRED						
8L-77330		Kit (trans. front pump screws & washers)-consists of the following (3) 352792-S Bolt (cover to pump body) (1) 8L-77339 Bolt (pump body to cover) (3) 8L-77336 Washer (flat)-special-Copper (1) 34805-S8 Lockwasher	1	1					
HBK-77330-A		Kit (trans. front pump screws and washers)-consists of the following (3) 352792-S Bolt (cover to pump body) (1) 1L-77339-A Bolt (pump body to cover) (3) 8L-77336 Washer (flat)-special-Copper (1) 34805-S8 Lockwasher				1			
8L-77331		Pump assy (transmission front oil)	1						
OL-77331		Pump assy (trans. front oil)-has raised numerals "905" cast on pump body	1	1					
1L-77331-A		Pump assy (transmission front oil)				1			
351772-S		Bolt (hex washer head)-5/16"-18 x 1/2"-pump assy to transmission case	2	2		2			
8L-77333		Valve (trans. front pump by pass)-1/2" O.D. x 13/32" I.D. x 5/8" long	1	1					
1L-77333-A		Valve (trans. front pump by pass)-9/16" O.D. x 15/32" I.D. x 5/8" long				1			
8L-77334		Seal (transmission front cover oil)	1	1		1			
8L-77336		Washer (trans. front cover to pump screw)-Copper-17/64" I.D. x 3/8" O.D. x 1/32" thick	3	3		3			
8L-77337		Gear (front unit drive)	1						
OL-77337		Gear assy (transmission front drive)		1		1			
8L-77340		Ring (transmission front oil pump seal)	2	2		2			
8L-77342		Washer (trans. front pump locating)-Steel-21/64" I.D.-1/2" O.D. x 3/32" thick	1	1		1			
8L-77346		Gasket (transmission front pump intake pipe)	1	1		1			
8L-77347		Key (woodruff)-.188"/.189" thick-trans. front pump drive	1	1		1			
8L-77348		Pipe (trans. front oil pump delivery)-3-15/16" overall length	1	1		1			
8L-77351		Pump assy (transmission rear oil)	1	1		1			
24388-S8		Bolt (hex head)-3/8"-16 x 1"-rear pump to transmission case	1	1		1			
24366-S8		Bolt (hex head)-5/16"-18 x 7/8"-rear pump to transmission case	2	2		2			
34806-S2		Lockwasher-5/16"	2	2		2			
8L-77353		Cover (transmission rear oil pump)	1	1		1			
42911-S		Bolt (hex-hd self locking)-1/4"-20 x 5/8"-rear pump cover to rear pump body	4	4		4			

# Lincoln and Lincoln Cosmopolitan

## CHASSIS PARTS CATALOGUE

### HYDRA-MATIC Transmission—Continued

#### HYDRA-MATIC TRANSMISSION CHART—CONTINUED

PART NUMBER	CLASS	PART NAME	HYDRA-MATIC TRANSMISSION						
			8L-7003	OL-7003	IL-7003-A				
			NUMBER REQUIRED						
		OL-77354 Plug (trans. throttle valve pressure regulator)		1					
		OL-77355 Seal (trans. pressure regulator to case)		1		1			
		8L-77360 Kit (trans. rear oil pump driven gear)-consists of the following (1) 8L-77358 Gear (rear oil pump driven) (1) 72869-S Pin (straight) (1) 72909-S Pin (straight)	1	1		1			
		72869-S Pin (straight)-3/16" x 7/8"-rear oil pump driven gear to shaft	1	1		1			
		8L-77366 Pipe (trans. rear oil pump discharge)-8-1/8" developed length	1						
		OL-77366 Pipe (trans. rear oil pump discharge)-w/o brass fitting		1		1			
		8L-77382 Gasket (trans. pressure regulator to case)-Fibre-1-5/64" I.D. x 1-5/16" O.D. x 3/32" thick	1						
		OL-77382 Gasket (trans. pressure regulator to case)-Copper		1		1			
		8L-77383 Plug assy (trans. pressure regulator valve)	1						
		OL-77383 Plug assy (trans. pressure regulator valve)		1					
	NS	1L-77383-A Plug assy (trans. pressure regulator valve)-serviced in HBK-77383-A				1			
		HBK-77383-A Kit (trans. pressure regulator plugs & gaskets)-consists of the following (1) OL-77355 Seal (1) OL-77382 Gasket (1) 1L-77383-A Plug assy (1) 1L-77384-A Valve (1) 1L-77745-A Valve				1			
	NS	1L-77384-A Valve (trans. pressure regulator reverse booster)-29/64" diameter x 7/8" long-serviced in HBK-77383-A Kit				1			
		8L-77385 Valve (trans. front pump pressure regulator)	1	1		1			
		8L-77387 Spring (trans. oil pressure regulator)-approx. 3-31/32" free length	1						
		OL-77387 Spring (trans. oil pressure regulator)-approx. 2-7/16" free length		1					
		1L-77387-A Spring (trans. oil pressure regulator)-3/4" O.D.-approx. 2-21/32" free length				1			
		8L-77388 Kit (trans. governor drive flange)-consists of the following (1) 8L-77389-B Flange (1) 72909-S Pin	1	1		1			

# Lincoln and Lincoln Cosmopolitan

## CHASSIS PARTS CATALOGUE

### HYDRA-MATIC Transmission—Continued

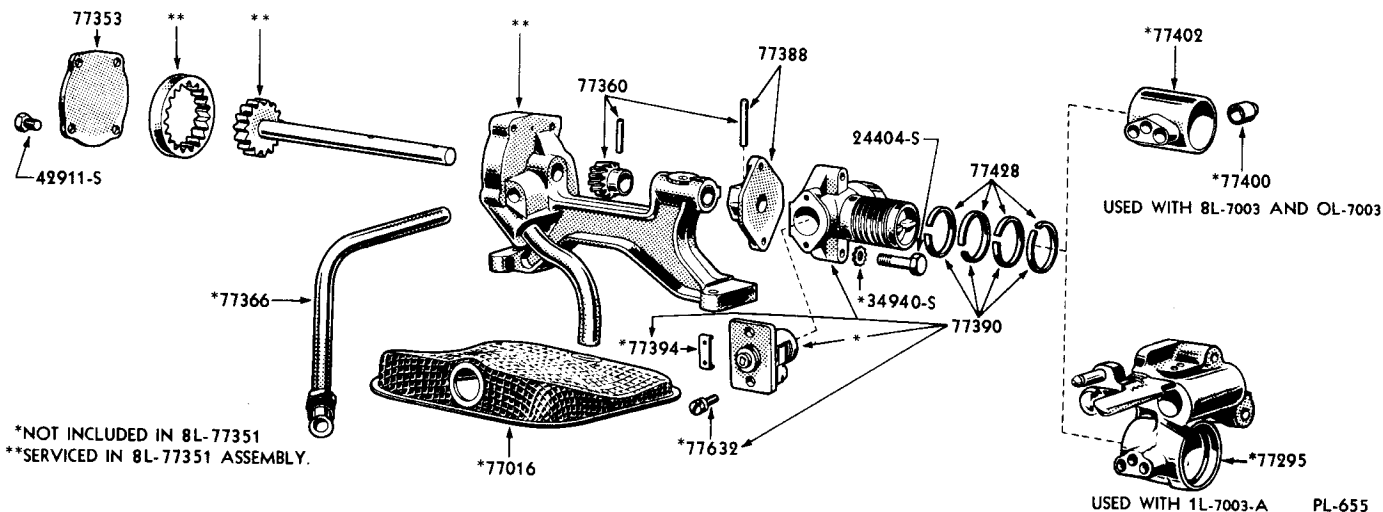

### TRANSMISSION REAR OIL PUMP AND RELATED PARTS

Basic numbers only shown on illustration. Order by Part Numbers shown in list of parts.

### HYDRA-MATIC TRANSMISSION CHART—CONTINUED

PART NUMBER	CLASS	PART NAME	HYDRA-MATIC TRANSMISSION				
			8L-7003	OL-7003	1L-7003-A		
			NUMBER REQUIRED				
NS	8L-77389-B	Flange (trans. governor drive)-serviced in 8L-77388 Kit	1	1	1		
	8L-77390	Governor assy (transmission)	1				
	OL-77390	Governor assy (transmission)		1			
	1L-77390-A	Governor assy (transmission)	1	1	1		
	24404-S7	Bolt (hex-hd)-1/4"-20 x 1-1/8"	2	2	2		
	34940-S2	Lockwasher-1/4"	2	2	2		
	72909-S2	Pin (straight)-3/16" x 1-1/4"-transmission governor drive shaft	1	1	1		
	8L-77391	Plunger & bushing assy (trans. governor high speed)	1	1	1		
	8L-77394	Stop (governor plunger)	2	2	2		
	OL-77395	Spring (trans. front servo check valve)		1	1		
	OL-77397	Ring (trans. front servo band release piston oil)		1	1		
	8L-77400	Plug (trans. governor sleeve)-3/4" o/all length	1	1			
	8L-77401	Pipe (trans. governor oil supply)	3	3	3		

# Lincoln and Lincoln Cosmopolitan

## CHASSIS PARTS CATALOGUE

### HYDRA-MATIC Transmission—Continued

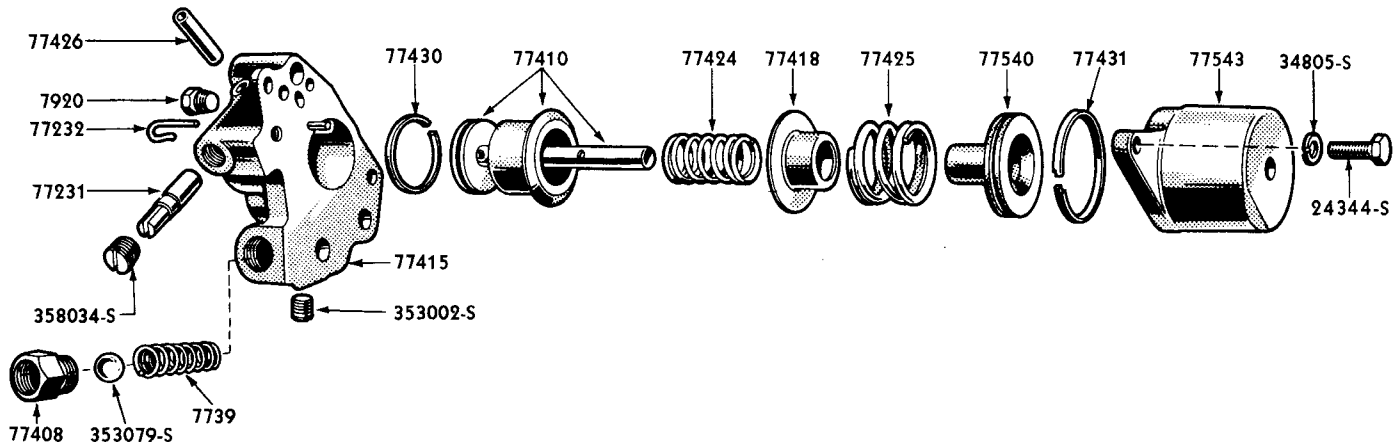

PL-654

### TRANSMISSION FRONT SERVO UNIT

Basic numbers only shown on illustration. Order by Part Numbers shown in list of parts.

### HYDRA-MATIC TRANSMISSION CHART—CONTINUED

PART NUMBER	CLASS	PART NAME	HYDRA-MATIC TRANSMISSION					
			8L-7003	OL-7003	IL-7003-A			
			NUMBER REQUIRED					
8L-77402		Sleeve (trans. governor oil delivery)	1	1				
8L-77404		Body assy (trans. front servo)	1					
8L-77408		Adapter (trans. rear pump tube)-11/16"-18 x 3/8" and 11/16"-18 female thread	1					
OL-77408		Adapter (trans. rear pump tube)-11/16"-18 x 1/2"		1		1		
1L-77409-A2		Body assy (trans. front servo exhaust valve)					1	
8L-77410		Piston assy (trans. front servo)	1					
OL-77410		Piston assy (trans. front servo)		1		1		
OL-77415		Body (trans. front servo)		1		1		
353079-S		Ball-1/2" diameter-trans. front servo		1		1		
24388-S8		Bolt (hex head)-3/8"-16 x 1"	1	1		1		
20222-S		Bolt (hex head)-3/8"-16 x 2"-front servo to case	1	1		1		
34807-S2		Lockwasher-3/8"	2	2		2		
73232-S		Pin (dowel)-1/8" x 1/2"-front servo piston locating	1	1		1		
353052-S5		Plug (slotted headless pipe)-1/8"	1	1		1		
358034-S		Plug (slotted headless pipe)-1/4"	1	1		1		

# Lincoln and Lincoln Cosmopolitan

## CHASSIS PARTS CATALOGUE

### HYDRA-MATIC Transmission—Continued

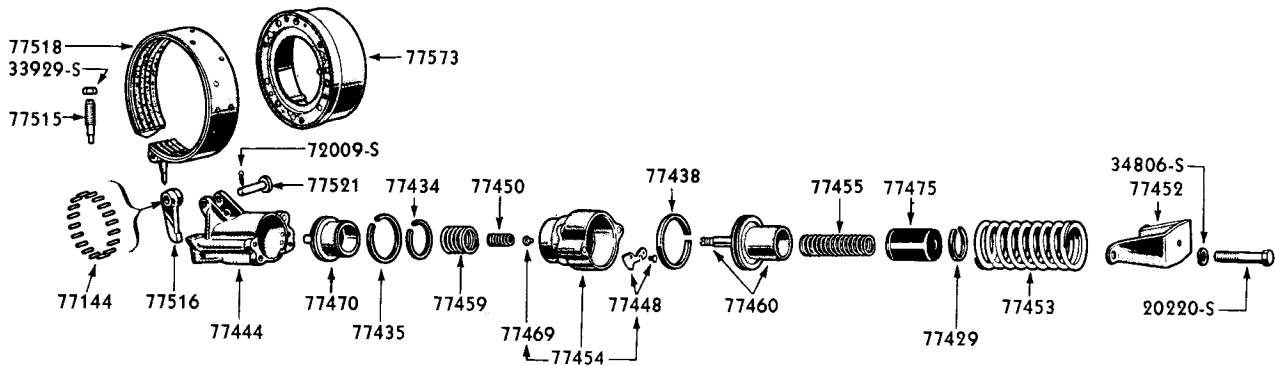

PL-814

### TRANSMISSION REAR SERVO UNIT AND RELATED PARTS

Basic numbers only shown on illustration. Order by Part Numbers shown in list of parts.

### HYDRA-MATIC TRANSMISSION CHART—CONTINUED

PART NUMBER	CLASS	PART NAME	HYDRA-MATIC TRANSMISSION					
			8L-7003	OL-7003	IL-7003-A			
			NUMBER REQUIRED					
8L-77418		Retainer (trans. front servo release spring)- 1-11/16" O.D.	1					
OL-77418		Retainer (trans. front servo release spring)- 1-13/16" O.D.		1	1			
8L-77419		Spring (trans. front pump by pass valve)- 3/8" O.D.-approx. 1-25/64" free length	1	1				
1L-77419-A		Spring (trans. front pump by pass valve)- 27/64" O.D.-approx. 1-23/32" free length			1			
8L-77424		Spring (trans. front servo retracting)- 13/16" O.D.-approx. 1-33/64" free length	1	1	1			
8L-77425		Spring (trans. front servo booster)-1-11/32" O.D.-approx. 61/64" free length	1	1	1			
8L-77426		Pipe (trans. servo oil transfer)-1-3/16" long	1	1	1			
8L-77428-B		Ring (trans. governor oil seal)-1-3/16" x 3/32"	4	5	5			
8L-77429-B		Ring (oil seal)-1-1/4" x 3/32"	1	1	1			
8L-77430		Ring (oil seal)-1-5/16" x 3/32"	1	1	1			
8L-77431		Ring (trans. governor oil collector)	1	1	1			
8L-77432-B		Ring (oil seal)-2" x 3/32"	4	4	4			
8L-77434-B		Ring (oil seal)-1-11/16" x 3/32"	1	1	1			
8L-77435-B		Ring (oil seal)-2-1/4" x 3/32"	1	1	1			
8L-77438		Ring (trans. rear servo accumulator oil seal)	1	1	1			

# Lincoln and Lincoln Cosmopolitan

## CHASSIS PARTS CATALOGUE

### HYDRA-MATIC Transmission—Continued

#### HYDRA-MATIC TRANSMISSION CHART—CONTINUED

PART NUMBER	CLASS	PART NAME	HYDRA-MATIC TRANSMISSION					
			8L-7003	OL-7003	IL-7003-A			
						NUMBER REQUIRED		
		8L-77444 Body assy (trans. rear servo)	1	1				
		1L-77444-A Body assy (trans. rear servo)			1			
		20222-S Bolt (hex-hd)-3/8"-16 x 2"-rear servo to case	2	2	2			
		34807-S2 Lockwasher-3/8"	2	2	2			
		8L-77448 Kit (trans. rear servo check valve)-consists of the following	1	1	1			
		(1) Rivet (flat head)						
		(1) Valve (rear servo check)						
		8L-77450 Spring (trans. rear servo pressure)-5/8" O.D.-approx. 1-15/64" free length	1	1	1			
		8L-77452 Retainer (trans. rear servo spring)	1	1	1			
		20220-S Bolt (hex-hd)-5/16"-18 x 2"-rear spring retainer to body	2	2	2			
		34806-S2 Lockwasher-5/16"	2	2	2			
		8L-77453 Spring (trans. rear servo compression)-1-29/32" O.D.-approx. 4-1/4" free length	1	1	1			
		8L-77454 Body assy (trans. rear servo accumulator)	1	1				
		1L-77454-A Body assy (trans. rear servo accumulator)			1			
		8L-77455 Spring (trans. rear servo)-inner-5/8" O.D.-approx. 3-25/32" free length	1	1	1			
NS		1L-77455 Spring (trans. rear servo)-1-5/64" O.D.-approx. 3-59/64" free length-serviced in HAK-77475-A Kit	1	1	1			
		8L-77459 Spring (trans. rear servo booster)-6-1/4 coils-1-5/16" O.D.-1-17/32" free length	1	1	1			
		8L-77460 Piston and stem assy (trans. rear servo accumulator)	1	1	1			
		8L-77465 Spring (trans. rear servo outer)-7/8" O.D.-approx. 3-15/32" free length	1	1	1			
		1L-77467-A Tube (trans. pressure regulator reverse oil)			1			
		8L-77469 Plunger (trans. rear servo check valve)	1	1	1			
		8L-77470 Piston & stem assy (trans. rear service booster)	1	1	1			
		8L-77475 Piston (trans. rear servo compensator)	1	1	1			
NS		1L-77475-A Piston (trans. rear servo compensator)-serviced in HAK-77475-A	1	1	1			
		HAK-77475-A Kit (trans. rear servo compensator piston and spring)-consists of the following	1	1	1			
		(1) 1L-77455-A Spring						
		(1) 1L-77475-A Piston						
		8L-77476 Body assy (trans. oil control valve inner)	1					
		8L-77483 Plug and gasket assy (trans. oil pan drain)	1	1	1			
		8L-77485 Gasket (trans. oil pan drain plug)	1	1	1			
		8L-77510 Band assy (trans. front)	1	1	1			

# Lincoln and Lincoln Cosmopolitan

## CHASSIS PARTS CATALOGUE

### HYDRA-MATIC Transmission—Continued

#### HYDRA-MATIC TRANSMISSION CHART—CONTINUED

PART NUMBER	CLASS	PART NAME	HYDRA-MATIC TRANSMISSION						
			8L-7003	OL-7003		1L-7003-A			
									NUMBER REQUIRED
8L-77515		Stop (trans. band anchor)	2	2		2			
33929-S7		Nut (hex)-1/2"-20-trans. band anchor stop	2	2		2			
8L-77516		Lever (trans. rear band actuating)	1	1		1			
8L-77518		Band assy (trans. rear)	1	1		1			
8L-77521		Pin (trans. rear band actuating lever)-3/8" dia. x 1-13/16" long-straight	1	1					
1L-77521-A		Pin (trans. rear band actuating lever)-3/8" dia. x 1-3/4" long-clevis	1	1		1			
72009-S		Cotter pin-3/32" x 5/8"	lor2	lor2		1			
8L-77530		Washer (trans. front clutch drum rear backing)- Steel-1-3/8" I.D. x 1-15/16" O.D. x 3/32" thick	1	1		1			
8L-77531		Piston (trans. front clutch cylinder)	1	1		1			
8L-77532		Drum assy (trans. front clutch)	1	1		1			
8L-77535		Kit (trans. clutch piston seal & expander)- consists of the following (1) Expander (piston oil seal)-inner (1) Expander (piston oil seal)-outer (1) Seal (piston)-2-7/8" diameter (1) Seal (piston)-5-1/8" diameter	2	2		2			
8L-77536		Drum and pin assy (trans. front)	1	1		1			
8L-77540		Piston (trans. front band release)-1-3/16" overall length	1						
OL-77540		Piston (trans. front band release)-1-1/8" overall length		1		1			
8L-77543		Cylinder (trans. front clutch band release)	1						
OL-77543		Cylinder (trans. front band release)-with milled slot and larger flat at edge		1		1			
24344-S7		Bolt (hex head)-1/4"-20 x 3/4"	2	2		2			
34805-S8		Lockwasher-1/4"	2	2		2			
8L-77551		Plate (trans. clutch driven)	11	11		11			
8L-77563		Plate assy (trans. clutch drive)	11	11		11			
8L-77572		Piston (trans. rear clutch cylinder)	1	1		1			
8L-77573		Drum and pin assy (trans. rear)	1	1		1			
1L-77573-A		Drum and pin assy (trans. rear)				1			
8L-77575		Pin (trans. rear clutch spring guide)-.116"/.122" diameter x 1-5/8" long	6	6		6			
8L-77578		Spring (trans. clutch release)-inner-15/64" O.D.-approx. 2-15/64" free length	12	12		12			
8L-77579		Hub (trans. rear clutch)	1	1		1			
8L-77581		Washer (trans. rear clutch hub thrust)-Bronze- grooved-2-7/8" O.D. x 1-15/16" I.D. x .087"/.091" thick	2	2		2			



# Lincoln and Lincoln Cosmopolitan

## CHASSIS PARTS CATALOGUE

### HYDRA-MATIC Transmission—Continued

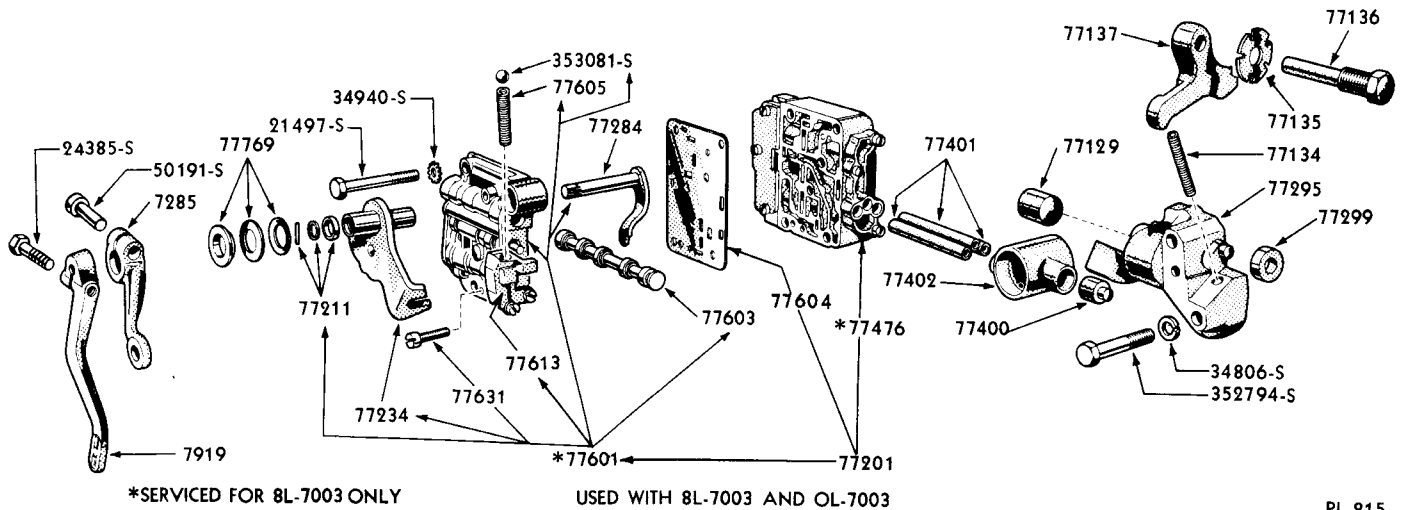

PL-815

### TRANSMISSION OIL CONTROL VALVE AND RELATED PARTS

Basic numbers only shown on illustration. Order by Part Numbers shown in list of parts.

### HYDRA-MATIC TRANSMISSION CHART—CONTINUED

PART NUMBER	CLASS	PART NAME	HYDRA-MATIC TRANSMISSION						
			8L-7003	OL-7003		1L-7003-A			
			NUMBER REQUIRED						
8L-77582		Spring (trans. clutch release)-outer-3/8" O.D. x 2-31/64" free length	12	12		12			
8L-77584		Ring (trans. rear clutch cylinder retainer)-6-3/8" O.D. x 5-7/8" I.D. x 3/32" thick	2	2		2			
1L-77590-A		Washer (trans. reverse clutch release spring retainer)-3-7/8" O.D. x 3-1/16" I.D.					1		
1L-77591-A		Cone (trans. reverse clutch stationary)-6-13/16" O.D. x 29/32" wide					1		
1L-77592-A		Spring (trans. reverse clutch release)-3-7/8" O.D. x 3-1/8" I.D.					1		
1L-77593-A		Tube (trans. reverse clutch oil)-3/8" O.D. x 6-7/16" long-"L" shaped					1		
1L-77594-A		Key (trans. reverse clutch stationary cone)-35/64" x 3/8" x 1/4"					1		
1L-77595-A		Spring (trans. reverse clutch piston release)-15/32" O.D.-approx. 1-11/32" free length					6		
1L-77596-A		Snap ring (trans. reverse clutch piston spring retainer)-3-1/4" O.D. x 2-7/8" I.D. x 1/16" thick					1		
1L-77598-A		Retainer (trans. reverse clutch piston spring)-4-1/4" O.D. x 3-5/32" I.D. x 5/64" thick					1		

# Lincoln and Lincoln Cosmopolitan

## CHASSIS PARTS CATALOGUE

### HYDRA-MATIC Transmission—Continued

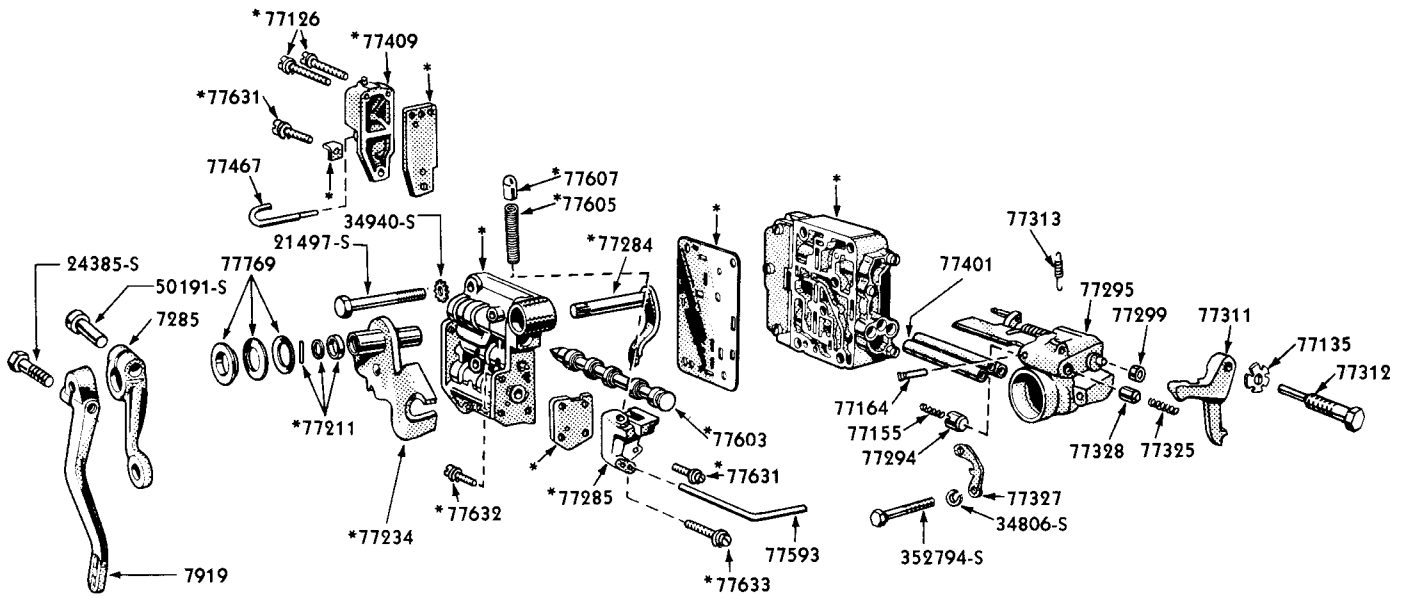

\*INCLUDED IN IL-77201-A ASSEMBLY

USED WITH IL-7003-A

PL-662

### TRANSMISSION OIL CONTROL VALVE AND RELATED PARTS

Basic numbers only shown on illustration. Order by Part Numbers shown in list of parts.

#### HYDRA-MATIC TRANSMISSION CHART—CONTINUED

PART NUMBER	CLASS	PART NAME	HYDRA-MATIC TRANSMISSION					
			8L-7003	OL-7003	IL-7003-A			
			NUMBER REQUIRED					
8L-77601		Body assy (trans. oil control valve outer)	1					
21497-S		Bolt (hex head)-1/4"-20 x 2"-control valve body to case	4	4	4			
34940-S2		Lockwasher (external tooth)-1/4"	4	4	4			
8L-77603		Valve (trans. manual control)-4-3/4" o/all length	1	1				
1L-77603-A		Valve (trans. manual control)-5-13/64" o/all length			1			
8L-77604		Plate (trans. valve body spacer)	1	1				
8L-77605		Spring (trans. manual valve detent)-9/32" O.D. -approx. 1-25/64" free length	1	1				
1L-77605-A		Spring (trans. manual valve detent)-13/64" O.D. -approx. 1-21/64" free length			1			
353081-S		Ball-5/16" diameter-manual valve detent	1	1				



# Lincoln and Lincoln Cosmopolitan

## CHASSIS PARTS CATALOGUE

### Steering Column Gear Shift

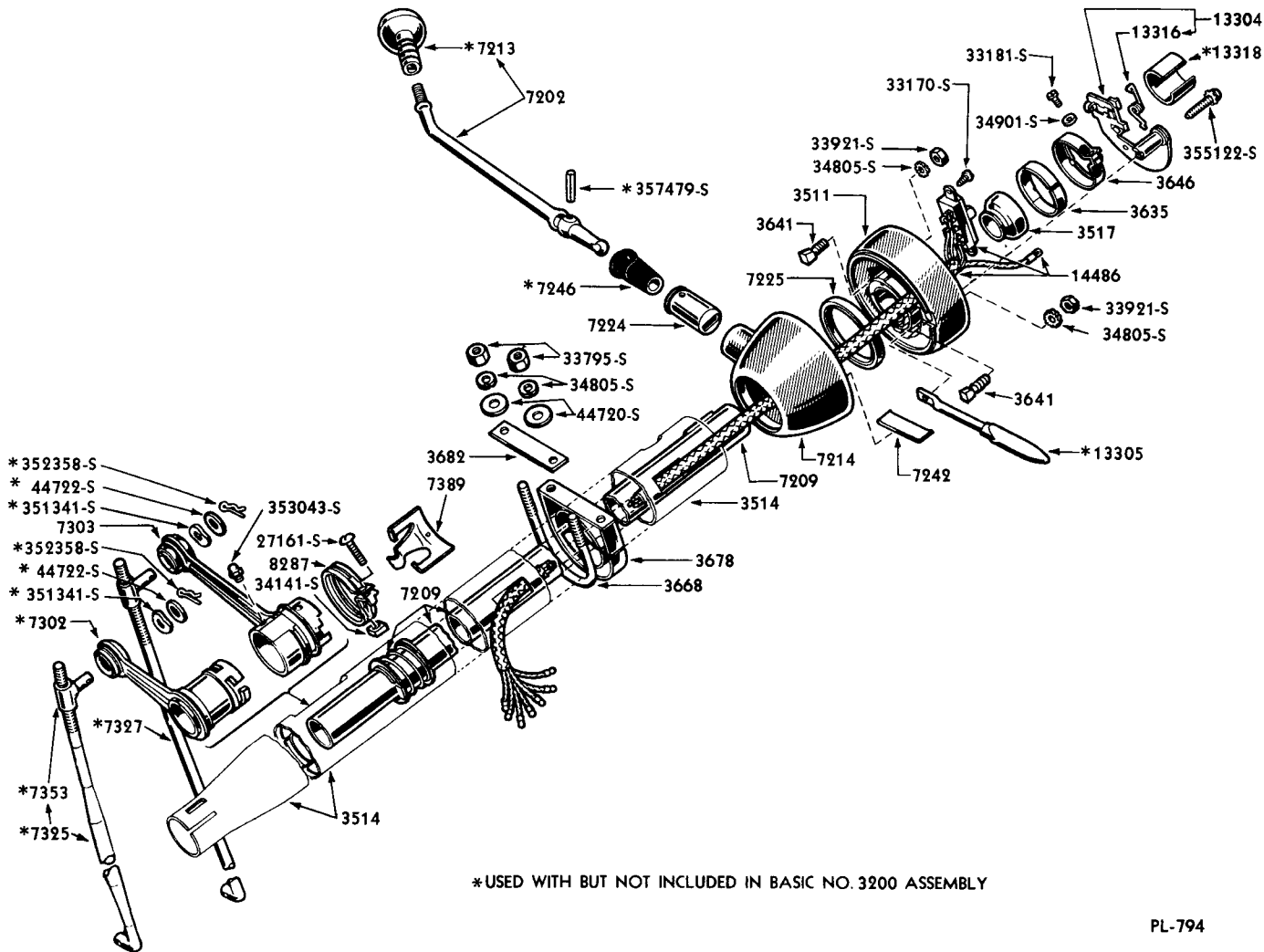

\*USED WITH BUT NOT INCLUDED IN BASIC NO. 3200 ASSEMBLY

PL-794

### STEERING COLUMN GEAR SHIFT (8L-7200-AA) AND RELATED PARTS

Basic numbers only shown on illustration. Order by Part Numbers shown in list of parts.

PART NUMBER	QTY	PART NAME	NO. REQ'D	MODEL	YEAR
8L 7200-AA		Gear shift assy (transmission)-Gold Fleck Derk Grey Metallic-gear shift lever and insulator opening approximately 2-1/4" in length	1	9L	49
8L 7200-AB	NS	Gear shift assy (transmission)-Lincoln Texture Green Metallic-gear shift lever and insulator opening approximately 2-1/4" in length-consisting parts same as used in 8L-7200-AA except painted parts- use 8L-7200-BE for service	1	9L	49
<p>++ Not used with HYDRA-MATIC transmission</p>					

# Lincoln and Lincoln Cosmopolitan

## CHASSIS PARTS CATALOGUE

### Steering Column Gear Shift-Continued

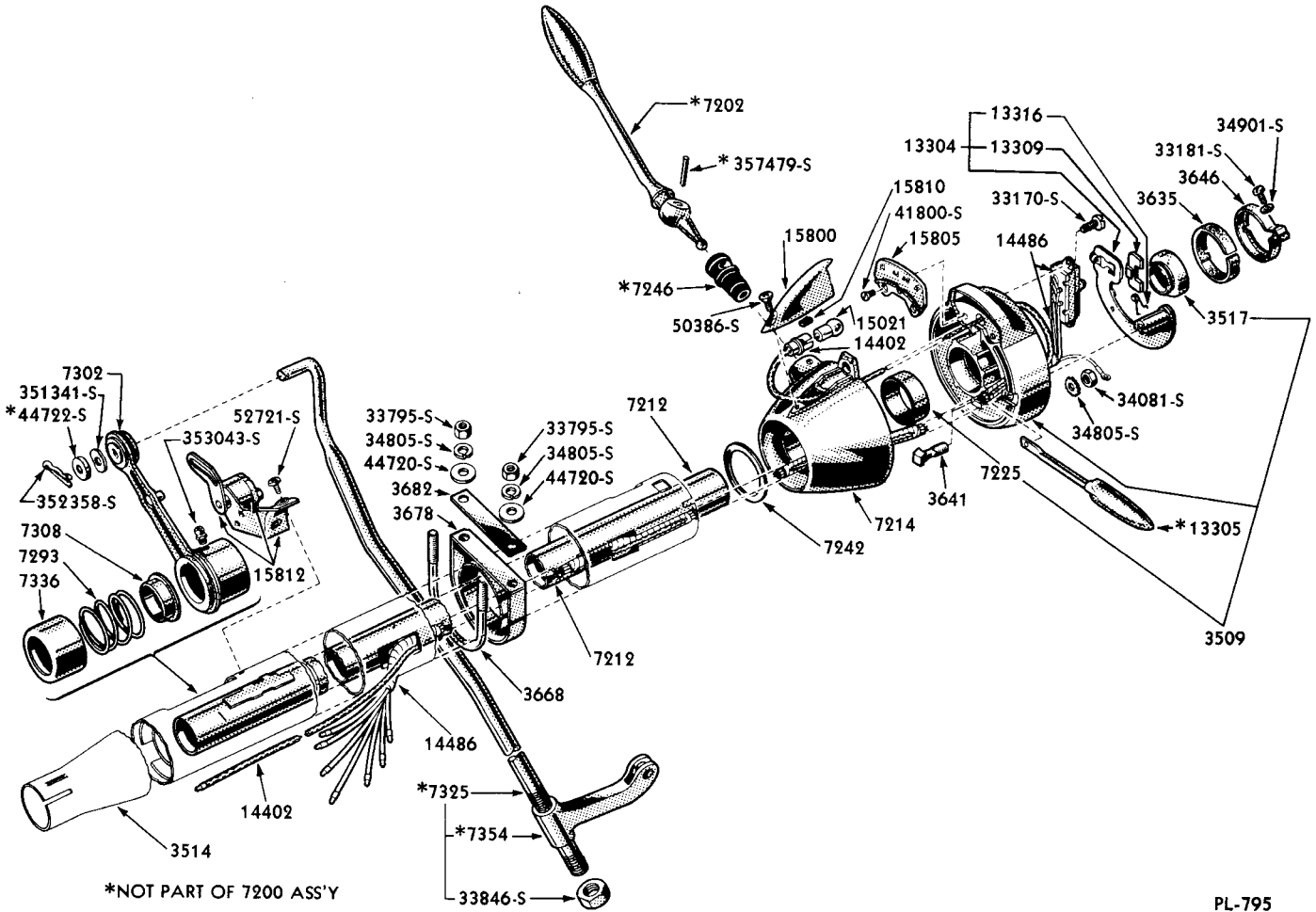

PL-795

### STEERING COLUMN GEAR SHIFT (8L-7200-CP) AND RELATED PARTS

Basic numbers only shown on illustration. Order by Part Numbers shown in list of parts.

PART NUMBER	UNDP	PART NAME	NO. REQ'D	MODEL	YEAR
**8L 7200-AC	NS	Gear shift assy (transmission)-Lincoln Texture Blue Metallic-gear shift lever and insulator opening approximately 2-1/4" in length-consisting parts same as used in 8L-7200-AA except painted parts-use 8L-7200-BE for service	1	9L	49
**8L 7200-AD	NS	Gear shift assy (transmission)-Lincoln Texture Tan Metallic-gear shift lever and insulator opening approximately 2-1/4" in length-consisting parts same as used in 8L-7200-AA except painted parts-use 8L-7200-BE for service	1	9L	49
** Not used with HYDRA-MATIC transmission					

# Lincoln and Lincoln Cosmopolitan

## CHASSIS PARTS CATALOGUE

PART NUMBER	QUANTITY	PART NAME	NO. REQ'D	MODEL	YEAR
<b>Steering Column Gear Shift—Continued</b>					
++8L 7200-BB	NS	Gear shift assy (transmission)-Lincoln Texture Green Metallic-gear shift lever and insulator opening approximately 3-1/2" in length-use 8L-7200-BE for service	1	9L	49
++8L 7200-BC	NS	Gear shift assy (transmission)-Lincoln Texture Blue Metallic-gear shift lever and insulator opening approximately 3-1/2" in length-use 8L-7200-BE for service	1	9L	49
++8L 7200-BD	NS	Gear shift assy (transmission)-Lincoln Texture Tan Metallic-gear shift lever and insulator opening approximately 3-1/2" in length-use 8L-7200-BE for service	1	9L	49
++8L 7200-BE		Gear shift assy (transmission)-in Prime-gear shift lever and insulator opening approximately 3-1/2" in length	1	9L	49
+8L 7200-CP		Gear shift assy (transmission)-in Prime-gear shift lever and insulator opening approximately 2-1/2" in length	1	9L	49
++8H 7200-AA	NS	Gear shift assy (transmission)-Gold Fleck Dark Gray Metallic-gear shift lever and insulator opening approx. 2-1/4" in length-repl. by 8H-7200-BE	1	9H	49
++8H 7200-AE		Gear shift assy (transmission)-in Prime-gear shift lever and insulator opening approximately 2-1/4" in length	1	9H	49
++8H 7200-BE		Gear shift assy (transmission)-in Prime-gear shift lever and insulator opening approximately 3-1/2" in length	1	9H	49
+8H 7200-CP		Gear shift assy (transmission)-in Prime-gear shift lever and insulator opening approximately 2-1/2" in length	1	9H	49
+OL 7200-BP		Gear shift assy (transmission)-in Prime-gear shift lever opening approx. 2-9/16" in length	1	OL	50
+OH 7200-BP		Gear shift assy (transmission)-in Prime-gear shift lever opening approx. 2-9/16" in length	1	OH	50
+1L 7200-BP		Gear shift assy (transmission)-in Prime	1	1L	51
+1H 7200-BP		Gear shift assy (transmission)-in Prime	1	1H	51
++OL 7200-AP	NS	Gear shift assy (trans.)-in Prime-service details	1	OL	50
++OH 7200-AP	NS	Gear shift assy (trans.)-in Prime-service details	1	OH	50
++1L 7200-AP	NS	Gear shift assy (trans.)-in Prime-service details	1	1L	51
++1H 7200-AP	NS	Gear shift assy (trans.)-in Prime-service details	1	1H	51

++ Not used with HYDRA-MATIC transmission

+ Used with HYDRA-MATIC transmission

# Lincoln and Lincoln Cosmopolitan

## CHASSIS PARTS CATALOGUE

### Steering Column Gear Shift—Continued

#### STEERING COLUMN GEAR SHIFT CHART

PART NUMBER	CLASS	PART NAME	STEERING COLUMN GEAR SHIFT														
			††8L-7200-AA	††8L-7200-BE	†8L-7200-CP	††8H-7200-AA	††8H-7200-AE	††8H-7200-BE	†8H-7200-CP	††0L-7200-AP	†0L-7200-BP	††0H-7200-AP	†0H-7200-BP	††1L-7200-AP	†1L-7200-BP	††1H-7200-AP	†1H-7200-BP
			NUMBER REQUIRED														
		8H-3509-BE Flange assy (steering column tube)-in Prime-includes (1) 21A-3517 Bearing and (1) 8L-7225-B Bearing		1					1		1		1		1		1
		8H-3509-CP Flange assy (steering column tube)-in Prime-includes (1) 21A-3517 Bearing and (1) 8L-7225-C Bearing			1				1		1		1		1		1
		1L-3509-AP Flange assy (steering column tube)-in Prime													1		1
		8L-3511-AA Flange (steering column tube) -Gold Fleck Dark Gray Metallic	1			1											
	NS	8L-3511-AB Flange (steering column tube) -Lincoln Texture Green Metallic-replaced by 8M-3511-AE	1														
	NS	8L-3511-AC Flange (steering column tube) -Mercury Texture Blue Metallic-replaced by 8M-3511-AE	1														
	NS	8L-3511-AD Flange (steering column tube) -Lincoln Texture Tan Metallic-replaced by 8M-3511-AE	1														
	NS	8L-3511-BB Flange (steering column tube) -Lincoln Texture Green Metallic-replaced by 8H-3509-BE		1													
	NS	8L-3511-BC Flange (steering column tube) -Mercury Texture Blue Metallic-replaced by 8H-3509-BE		1													
	NS	8L-3511-BD Flange (steering column tube) -Lincoln Texture Tan Metallic-replaced by 8H-3509-BE		1													
	NS	8H-3511-BE Flange (steering column tube) -in Prime-replaced by 8H-3509-BE		1				1									
		8M-3511-AE Flange (steering column tube) -in Prime	1														

† Used with HYDRA-MATIC transmission  
 †† Not used with HYDRA-MATIC transmission

# Lincoln and Lincoln Cosmopolitan

## CHASSIS PARTS CATALOGUE

### Steering Column Gear Shift—Continued

#### STEERING COLUMN GEAR SHIFT CHART—CONTINUED

PART NUMBER	CLASS	PART NAME	STEERING COLUMN GEAR SHIFT														
			††8L-7200-AA	††8L-7200-BE	†8L-7200-CP	††8H-7200-AA	††8H-7200-AE	††8H-7200-BE	†8H-7200-CP	††0L-7200-AP	†0L-7200-BP	††0H-7200-AP	†0H-7200-BP	††1L-7200-AP	†1L-7200-BP	††1H-7200-AP	†1H-7200-BP
			NUMBER REQUIRED														
8H-3514-AA		Tube and retainer assy (steering column)-Gold Fleck Dark Gray Metallic -approx. 42-19/32" o/ell length				1											
8H-3514-AE		Tube and retainer assy (steering column)-in Prime-approx. 42-19/32" overall length				1											
8L-3514-AE		Tube and retainer assy (steering column)-in Prime-approx. 44-1/32" overall length	1														
8H-3514-BE		Tube assy (steering column) -in Prime-approx. 42-17/32" overall length					1										
8L-3514-BB		Tube assy (steering column) -Lincoln Texture Green Metallic-approx. 43-31/32" overall length		1													
8L-3514-BC		Tube assy (steering column) -Mercury Texture Blue Metallic-approx. 43-31/32" overall length		1													
8L-3514-BD		Tube assy (steering column) -Lincoln Texture Tan Metallic-approx. 43-31/32" overall length		1													
8L-3514-BE		Tube assy (steering column) -in Prime-approx. 43-31/32" overall length		1													
8L-3514-CP		Tube assy (steering column) -in Prime-approx. 43-31/32" overall length			1												
8H-3514-CP		Tube assy (steering column) -in Prime-approx. 42-17/32" overall length						1									
0L-3514-AP		Tube assy (steering column) -in Prime							1				1				
0L-3514-BP		Tube assy (steering column)- in Prime-approx. 43-31/32" overall length							1		1						
0H-3514-AP		Tube assy (steering column) -in Prime									1				1		

† Used with HYDRA-MATIC transmission

†† Not used with HYDRA-MATIC transmission





# Lincoln and Lincoln Cosmopolitan

## CHASSIS PARTS CATALOGUE

### Steering Column Gear Shift—Continued

#### STEERING COLUMN GEAR SHIFT CHART—CONTINUED

PART NUMBER	CLASS	PART NAME	STEERING COLUMN GEAR SHIFT														
			#8L-7200-AA	#8L-7200-BE	#8L-7200-CP	#8H-7200-AA	#8H-7200-AE	#8H-7200-BE	#8H-7200-CP	#0L-7200-AP	#0L-7200-BP	#0H-7200-AP	#0H-7200-BP	#1L-7200-AP	#1L-7200-BP	#1H-7200-AP	#1H-7200-BP
			NUMBER REQUIRED														
		8L-3678-AA Bracket (steering column)- Gold Fleck Dark Gray Metallic	1			1											
		8M-3678-AE Bracket (steering column)- in Prime	1	1	1	1	1	1	1								
		OL-3678 Saddle assy (strg. column "U" bolt)-used with OL-3668							1	1	1	1	1	1	1	1	
		8L-3682 Shim (steering column brkt.)	2	2	2	2	2	2	2								
	NS	OL-3682 Insulator (strg. column saddle)-45/64" wide x 1-7/8" long x 1/8" wide- make locally							1	1	1	1	1	1	1	1	
8L 7201-B		Housing, levers, cam and shafts assy (trans. gear shift)	Refer to Trans. Gear Shift Housing, Levers, Cam & Shafts Group														
*8L 7202-AA		Lever, ball & insulator assy (trans. gear shift)-Gold Fleck Dark Gray Metallic lever- uses 7EH-7213 Gold Fleck Dark Gray Metallic and 8M-7246-A-53/64" O.D.	1			1											
*8L 7202-AB		Lever, ball & insulator assy (trans. gear shift)-Chrome finish lever-uses 8L-7213-AB Green Plastic and 8M-7246-A-53/64" O.D.	1				1										
*8L 7202-AC		Lever, ball & insulator assy (trans. gear shift)-Chrome finish lever-uses 8L-7213-AC Blue Plastic and 8M-7246-A-53/64" O.D.	1				1										
*8L 7202-AD		Lever, ball & insulator assy (trans. gear shift)-Chrome finish lever-uses 8L-7213-AD Tan Plastic and 8M-7246-A-53/64" O.D.	1				1										
*8L 7202-BB	NS	Lever, ball & insulator assy (trans. gear shift)-Chrome finish lever-uses 8L-7213-AB Green Plastic and 8M-7246-B-3/4" O.D. -replaced by 8L-7202-BC		1				1									
*8L 7202-BC		Lever, ball & insulator assy (trans. gear shift)-Chrome finish lever-uses 8L-7213-AC Blue Plastic and 8M-7246-B-3/4" O.D.		1				1									
*8L 7202-BD	NS	Lever, ball & insulator assy (trans. gear shift)-Chrome finish lever-uses 8L-7213-AD Tan Plastic and 8M-7246-B-3/4" O.D. -replaced by 8L-7202-BC		1				1									
*8L 7202-CA		Lever, knob & insulator assy (trans. gear shift)-Chrome finish lever-uses 8L-7213-BA Green Plastic and 8M-7246-B-3/4" O.D.			1				1								
*8L 7202-CB		Lever, knob & insulator assy (trans. gear shift)-Chrome finish lever-uses 8L-7213-BB Blue Plastic and 8M-7246-B-3/4" O.D.			1				1								

+ Used with HYDRA-MATIC transmission  
 ++ Not used with HYDRA-MATIC transmission  
 \* Used with but not part of 7200 assy

# Lincoln and Lincoln Cosmopolitan

## CHASSIS PARTS CATALOGUE

### Steering Column Gear Shift-Continued

#### STEERING COLUMN GEAR SHIFT CHART-CONTINUED

PART NUMBER	CLASS	PART NAME	STEERING COLUMN GEAR SHIFT														
			††8L-7200-AA	††8L-7200-BE	†8L-7200-CP	††8H-7200-AA	††8H-7200-AE	††8H-7200-BE	†8H-7200-CP	††0L-7200-AP	††0L-7200-BP	††0H-7200-AP	††0H-7200-BP	††1L-7200-AP	††1L-7200-BP	††1H-7200-AP	††1H-7200-BP
			NUMBER REQUIRED														
*8L 7202-CC		Lever, knob & insulator assy (trans. gear shift)-Chrome finish lever-uses 8L-7213-BC Tan Plastic and 8M-7246-B-3/4" O.D.			1				1								
0L 7202-A		Lever assy (trans. gear shift)-Black knob									1	1	1	1			
*0L 7202-B		Lever, knob & insulator assy (trans. gear shift)-Chrome lever & Black oblong knob									1	1	1	1			
*1L 7202-B		Lever, knob & insulator assy (trans. gear shift)-Chrome lever with Oyster White oblong knob												1	1		
		*357479-S15 Pin (grooved)-3/16" x 1" -gear shift lever to steering column	1	1	1	1	1	1	1	1	1	1	1	1	1	1	
8M 7209		Tube and selector spring assy (trans. gear shift)-32-3/4" overall length	1			1	1										
*8L 7210-AA	NS	Lever (trans. gear shift)-replaced by 8L-7202-AA	1			1	1										
8M 7212-B	NS	Tube assy (trans. gear shift)-31-15/16" from gear shift lever hole to shift lever lug -replaced by 8M-7212		1				1									
0M 7212		Tube assy (trans. gear shift)-31-23/32" from gear shift lever hole to lower shift lever lug		1				1	1		1		1		1		
8L 7212		Tube assy (trans. gear shift)-29-9/32" from gear shift lever hole to lower shift lever lug			1				1	1	1		1		1	1	
*7EH 7213		Ball assy (trans. gear shift lever)-Gold Fleck Dark Gray Metallic	1			1	1										
*8L 7213-AB		Ball assy (trans. gear shift lever)-Green Plastic		1			1	1									
*8L 7213-AC		Ball assy (trans. gear shift lever)-Blue Plastic		1			1	1									
*8L 7213-AD		Ball assy (trans. gear shift)-Tan Plastic		1			1	1									
*8L 7213-BA		Knob (trans. gear shift lever)-Green Plastic			1				1								
*8L 7213-EB		Knob (trans. gear shift lever)-Blue Plastic			1				1								
*8L 7213-BC		Knob (trans. gear shift lever)-Tan Plastic			1				1								
8L 7214-AA	NS	Socket assy (trans. gear shift lever)-Gold Fleck Dark Gray Metallic-replaced by 8M-7214-AE	1			1	1										
8M 7214-AE		Socket assy (trans. gear shift lever)-in Prime	1	1		1	1	1									
8H 7214-BP		Socket assy (trans. gear shift lever)-in Prime			1				1								
0L 7214-AP	NS	Socket assy (trans. gear shift lever)-In Prime -replaced by 1M-7214-CP								1		1		1		1	
1M 7214-CP		Socket assy (trans. gear shift lever)								1		1		1		1	

\* Used with but not part of the 7200 assy

† Used with HYDRA-MATIC transmission

†† Not used with HYDRA-MATIC transmission

# Lincoln and Lincoln Cosmopolitan

## CHASSIS PARTS CATALOGUE

### Steering Column Gear Shift—Continued

#### STEERING COLUMN GEAR SHIFT CHART—CONTINUED

PART NUMBER	CLASS	PART NAME	STEERING COLUMN GEAR SHIFT														
			++8L-7200-AA	++8L-7200-BE	+8L-7200-CP	++8H-7200-AA	++8H-7200-AE	++8H-7200-BE	+8H-7200-CP	++0L-7200-AP	+0L-7200-BP	++0H-7200-AP	+0H-7200-BP	++1L-7200-AP	+1L-7200-BP	++1H-7200-AP	+1H-7200-BP
			NUMBER REQUIRED														
8L 7222-A		Housing (trans. gear shift)	Refer to Trans. Gear Shift Housing, Levers, Cam & Shafts Group														
8L 7222-B		Cover (transmission case side)	Refer to HYDRA-MATIC Transmission Group														
8L 7223-A		Gasket (trans. gear shift housing)-LHD	Refer to Trans. Gear Shift Housing, Levers, Cam & Shafts Group														
8L 7223-B		Gasket (trans. case side cover)	Refer to HYDRA-MATIC Transmission Group														
8M 7224-A		Sleeve (trans. gear shift lever socket)	1			1	1										
8M 7225-A		Bearing (trans. gear shift lever socket)- 2.20" I.D. x 2.45" O.D. x .31" wide	1			1	1										
8M 7225-B		Bearing (trans. gear shift lever socket)- 1.31" I.D. x 1.50" O.D. x .50" wide		1	1		1	1	1	1	1	1	1	1	1		
8M 7225-C		Bearing (trans. gear shift lever socket)- 2.12" I.D. x 2.45" O.D. x .31" wide	1			1	1										
8H 7228-BE		Socket (trans. gear shift lever)-in Prime		1			1		1		1		1		1		
8L 7230		Fork (intermediate and high gear shifter)	Refer to Trans. Gear Shift Housing, Levers, Cam & Shafts Group														
8L 7231		Fork (low and reverse gear shifter)	Refer to Trans. Gear Shift Housing, Levers, Cam & Shafts Group														
8L 7233-A		Sleeve (trans. interlock)-1.287" long	Refer to Trans. Gear Shift Housing, Levers, Cam & Shafts Group														
8L 7233-B		Sleeve (trans. interlock)-1.291" long	Refer to Trans. Gear Shift Housing, Levers, Cam & Shafts Group														
8L 7233-C		Sleeve (trans. interlock)-1.295" long	Refer to Trans. Gear Shift Housing, Levers, Cam & Shafts Group														
8L 7233-D		Sleeve (trans. interlock)-1.299" long	Refer to Trans. Gear Shift Housing, Levers, Cam & Shafts Group														
8L 7234		Spring (trans. mesh lock)	Refer to Trans. Gear Shift Housing, Levers, Cam & Shafts Group														
8L 7235		Pin (gear shifter interlock)	Refer to Trans. Gear Shift Housing, Levers, Cam & Shafts Group														
8M 7242-A		Spring (gear shift anti vibrator)-2-1/32" long	1			1	1										
8M 7242-B		Spring (gear shift anti vibrator)-1-31/64" I.D. x 1-51/64" O.D.		1	1		1	1		1		1					
1M 7242-A		Spring (gear shift anti vibrator)-1-1/2" I.D. x 1-13/16" O.D. x 1/32" thick-dished						1		1		1	1	1	1		
*8M 7246-A		Insulator (trans. gear shift lever)-53/64" O.D.	1			1	1										
*8M 7246-B		Insulator (trans. gear shift lever)-3/4" O.D.		1	1		1	1	1	1	1	1	1	1	1		
8L 7280-B		Cam and shaft assy (trans. high and intermediate shift)	Refer to Trans. Gear Shift Housing, Levers, Cam & Shafts Group														
8L 7282-B		Cam and shaft assy (trans. low and reverse shift)	Refer to Trans. Gear Shift Housing, Levers, Cam & Shafts Group														
8L 7285-B		Lever assy (trans. high & intermediate shift)	Refer to Trans. Gear Shift Housing, Levers, Cam & Shafts Group														
8L 7285-C		Lever (trans. outer shifter)	Refer to HYDRA-MATIC Transmission Group														
8L 7290-B		Lever assy (trans. low and reverse shift)	Refer to Trans. Gear Shift Housing, Levers, Cam & Shafts Group														
8M 7293		Spring (trans. gear shift selector)-4 coils -1-5/16" O.D. x 1-3/8" long		1	1		1	1	1	1	1	1	1	1	1		

\* Used with but not part of the 7200 assembly  
 + Used with HYDRA-MATIC transmission  
 ++ Not used with HYDRA-MATIC transmission

# Lincoln and Lincoln Cosmopolitan

## CHASSIS PARTS CATALOGUE

### Steering Column Gear Shift-Continued

#### STEERING COLUMN GEAR SHIFT CHART-CONTINUED

PART NUMBER	CLASS	PART NAME	STEERING COLUMN GEAR SHIFT														
			††8L-7200-AA	††8L-7200-BE	†8L-7200-CP	††8H-7200-AA	††8H-7200-AE	††8H-7200-BE	†8H-7200-CP	††0L-7200-AP	†0L-7200-BP	††0H-7200-AP	†0H-7200-BP	††1L-7200-AP	†1L-7200-BP	††1H-7200-AP	†1H-7200-BP
			NUMBER REQUIRED														
8M 7302-A		Lever and insulator assy (trans. gear shift) -intermediate & high-hub is 2-5/32" long	1			1	1										
8M 7302-B		Lever and insulator assy (trans. gear shift) -intermediate & high-hub is 1-13/64" long		1				1		1		1			1		
8L 7302		Lever and insulator assy (trans. gear shift)			1				1		1			1		1	
8M 7303-A		Lever and insulator assy (trans. gear shift) -low and reverse-hub is 1-7/8" long	1			1	1									1	
8M 7303-B		Lever and insulator assy (trans. gear shift) -low and reverse-hub is 1-13/16" long		1				1		1		1			1		
		87907-S8 Fitting (lubricator)- 1/4"-28	1	1		1	1	1									
8M 7308-B		Retainer (trans. gear shift selector spring) -1-17/32" O.D.		1	1			1	1	1	1	1	1	1	1	1	
*8M 7325-B		Rod assy (trans. high and intermediate gear shift)-17-15/16" overall length	1	1													
*8H 7325-A		Rod assy (trans. high and intermediate gear shift)-17-5/8" overall length				1	1	1				1				1	
*8H 7325-B		Rod assy (manual shift)-17-27/32" overall length-replaced by 8L-7325							1		1		1		1	1	
†8L 7325		Rod assy (manual shift)-18-45/64" overall length			1				1		1		1		1	1	
*8M 7327		Rod assy (trans. low and reverse gear shift) -19-15/16" overall length	1	1													
*8H 7327		Rod assy (trans. low and reverse gear shift) -19-1/8" overall length				1	1	1				1				1	
		*352358-S2 Pin (self locking)-9/32" x 61/64"	2	2	1	2	2	2	1	2	1	2	1	2	1	2	
		*44722-S8 Washer (flat)-5/16"	2	2	1	2	2	2	1	2	1	2	1	2	1	2	
		*351341-S7 Washer (flat spring)- 21/64" I.D. x 5/8" O.D.	2	2	1	2	2	2	1	2	1	2	1	2	1	2	
8M 7336-B		Spacer (trans. gear shift arm hub)-1-39/64" O.D.		1	1			1	1	1	1	1	1	1	1	1	
*8M 7353		Sleeve (trans. gear shift rod adjustment)	2	2		2	2	2		2		2		2		2	
AB 7353-A		Sleeve (trans. gear shift connecting rod adjustment)	2	2		2		2		2		2		2		2	
*8L 7354		Clevis (manual shift rod)			1				1		1		1		1	1	
		*33846-S2 Nut (hex)-1/2"-20- attaches manual shift rod to clevis			1				1		1		1		1	1	
8M 7389		Spring (trans. gear shift neutral)	1	1		1	1	1		1		1		1		1	
8L 7442-A		Rod,nut and clevis assy (bell crank to trans. oil control valve)	Refer to Accelerator Group														

\* Used with but not part of the 7200 Assembly  
 † Used with HYDRA-MATIC transmission  
 †† Not used with HYDRA-MATIC transmission  
 † Adjust clevis (8L-7354) to proper length to make 8H-7325-B

# Lincoln and Lincoln Cosmopolitan

## CHASSIS PARTS CATALOGUE

### Steering Column Gear Shift—Continued

#### STEERING COLUMN GEAR SHIFT CHART—CONTINUED

PART NUMBER	CLASS	PART NAME	STEERING COLUMN GEAR SHIFT														
			††8L-7200-AA	††8L-7200-BE	†8L-7200-CP	††8H-7200-AA	††8H-7200-AE	††8H-7200-BE	†8H-7200-CP	††0L-7200-AP	†0L-7200-BP	††0H-7200-AP	†0H-7200-BP	††1L-7200-AP	†1L-7200-BP	††1H-7200-AP	†1H-7200-BP
			NUMBER REQUIRED														
8L 7442-B		Rod, nut and clevis assy (bell crank to valve shift lever)-22-29/32" overall length	Refer to Accelerator Group														
		B-8287-A Clamp assy (neutral spring to steering column)	1	1		1	1	1									
		34141-S7 Nut (plain)-No. 10-32	1	1		1	1	1									
		27161-S Screw (round head)-No. 10-32 x 1-1/4"	1	1		1	1	1									
		8L-13304 Plate assy (turn signal switch)	1	1	1	1	1	1	1	1	1	1					
		1M-13304-A Plate assy (turn signal switch)											1	1	1	1	
		*8L-13305-AA Handle & shank assy (turn signal switch)-Gold Fleck Dark Gray Metallic	1			1											
		*8L-13305-AB Handle & shank assy (turn signal switch)-Lincoln Texture Green Metallic	1	1	1		1	1	1								
		*8L-13305-AC Handle & shank assy (turn signal switch)-Lincoln Texture Blue Metallic	1	1	1		1	1	1								
		*8L-13305-AD Handle & shank assy (turn signal switch)-Lincoln Texture Tan Metallic	1	1	1		1	1	1								
		*0M-13305 Handle & shank assy (turn signal switch)								1	1	1	1				
		*1M-13305-A Handle & shank assy (turn signal switch)-Black handle												1	1	1	1
		*1M-13305-B Handle & shank assy (turn signal switch)-Oyster White handle													1		1
		*34939-S2 Lockwasher (external tooth)-No. 10-replaced by 355122-S8	1	1	1	1	1	1	1	1							
		*39147-S2 Screw (pan-head)-No. 10-32 x 1-1/8"-replaced by 355122-S8	1	1	1	1	1	1	1	1							
		*355122-S8 Screw & external tooth washer assy (hex-hd)-No. 10-32 x 1-1/8"	1	1	1	1	1	1	1	1	1	1	1	1	1	1	1
		8L-13309-B Pawl (turn signal switch)	1	1	1	1	1	1	1	1	1	1	1				
		1M-13309-A Pawl (turn signal switch)												1	1	1	1
		8L-13316 Spring (turn signal switch pawl)	1	1	1	1	1	1	1	1	1	1	1				
		1M-13316-A Spring (turn signal switch pawl)												1	1	1	1
		*8L-13318-A Cam (directional signal turn off)	1	1	1	1	1	1	1	1	1	1	1	1	1	1	1

\* Used with but not part of the 7200 Assembly

† Used with HYDRA-MATIC transmission

†† Not used with HYDRA-MATIC transmission

# Lincoln and Lincoln Cosmopolitan

## CHASSIS PARTS CATALOGUE

### Steering Column Gear Shift—Continued

#### STEERING COLUMN GEAR SHIFT CHART—CONTINUED

PART NUMBER	CLASS	PART NAME	STEERING COLUMN GEAR SHIFT																			
			††8L-7200-AA	††8L-7200-BE	†8L-7200-CP	††8H-7200-AA	††8H-7200-AE	††8H-7200-BE	†8H-7200-CP	††0L-7200-AP	††0L-7200-BP	††0H-7200-AP	†0H-7200-BP	††1L-7200-AP	†1L-7200-BP	††1H-7200-AP	†1H-7200-BP					
			NUMBER REQUIRED																			
		★OM-13322	Screw & external tooth lock-washer assy (hex-hd)-No. 10-32 x 1-1/4"-used with OM-13305									1	1	1	1			1		1		
		1M-13343-A	Spring (turn signal switch plate retainer)																1	1	1	1
		8L-14402	Wire and socket assy (trans. gear shift indicator lamp)			1				1		1		1					1		1	
		8L-14486	Switch and wiring assy (turn signal)	1	1	1	1	1	1	1	1	1		1					1		1	
		OL-14486	Switch and wiring assy (turn signal)									1		1								
		1M-14486-A	Switch and wiring assy (turn signal)																	1		1
		356632-S	Grommet-Rubber-for wiring thru steering column									1		1				1	1	1	1	
		33170-S7	Screw (pan-hd self tap.)-No. 10-12 x 1/4"	2	2	2	2	2	2	2	2	2	2	2	2	2	2	2	2	2	2	
		48-15021	Bulb (trans. gear shift indicator)-1 C.P.-S.C.			1				1		1		1				1		1		
		8H-15800-AP	Housing assy (trans. gear shift indicator lamp)-in Prime			1				1		1		1				1		1		
		50386-S13	Screw (cross recessed oval hd)-No. 6-32 x 1/2"			1				1		1		1				1		1		
		8L-15805	Dial (trans. gear shift indicator)			1				1												
		OL-15805	Dial (trans. gear shift indicator)									1		1				1		1		
		41800-S8	Screw (flat-hd self tap.)-No. 6-32 x 1/4"			2				2		2		2				2		2		
	NS	8L-15810	Pad (trans. gear shift indicator lamp)-Rubber-1/8" x 1/4" x 5/16"-secure locally			1				1		1		1				1		1		
		8L-15812	Switch and bracket assy (trans. gear shift neutral)			1				1		1		1				1		1		
		42360-S7	Screw (hex-hd self tap.)-No. 10-16 x 3/8"			2				2		2		2				2		2		
		34939-S8	Lockwasher (external tooth)-No. 10			2				2		2		2				2		2		
		OL-33680	Anti squeak (strg. column saddle)-Fibre-used with OL-3678									1	1	1	1	1	1	1	1	1		

★ Used with but not part of the 7200 Assembly

† Used with HYDRA-MATIC transmission

†† Not used with HYDRA-MATIC transmission

# Lincoln and Lincoln Cosmopolitan

## CHASSIS PARTS CATALOGUE

### Transmission Gear Shift Housing, Levers, Cam and Shafts

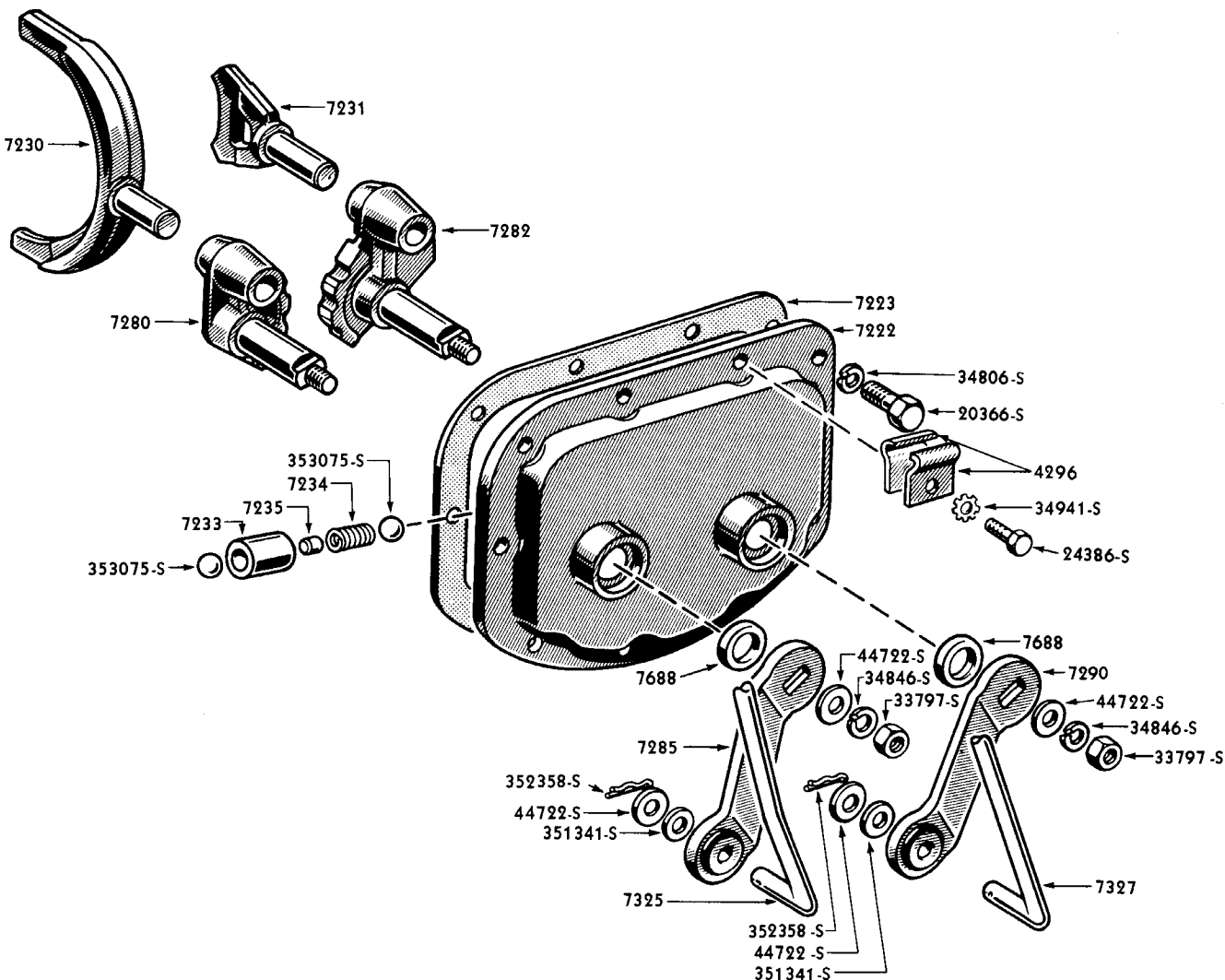

PL-807

### TRANSMISSION GEAR SHIFT HOUSING, LEVERS, CAM AND SHAFTS (8L-7201-B) AND RELATED PARTS

Basic numbers only shown on illustration. Order by Part Numbers shown in list of parts.

PART NUMBER	QTY	PART NAME	NO. REQ'D	MODEL	YEAR 19__
8L-4296		Clip (overdrive control cable)	1	9L,9H,OL,OH,1L,1H	49-51
34941-S7		Lockwasher (external tooth)- 5/16"-clip to gear shift hsg.	1	9L,9H,OL,OH,1L,1H	49-51
8L-7201-B		Housing assy (trans. gear shift)	1	9L,9H,OL,OH,1L,1H	49-51
24386-S8		Bolt (hex-hd)-5/16"-18 x 7/8"- gear shift housing assy to transmission	9	9L,9H,OL,OH,1L,1H	49-51
34806-S7		Lockwasher-5/16"-gear shift housing assy to transmission	9	9L,9H,OL,OH,1L,1H	49-51



# Lincoln and Lincoln Cosmopolitan

## CHASSIS PARTS CATALOGUE

PART NUMBER	PART NAME	NO. REQ'D	MODEL	YEAR
8L-7222-A	Housing (transmission gear shift)	1	9L,9H,OL,OH,LL,1H	49-51
8L-7223-A	Gasket (trans. gear shift housing)	1	9L,9H,OL,OH,LL,1H	49-51
8L-7230	Fork (inter. and high gear shifter)	1	9L,9H,OL,OH,LL,1H	49-51
8L-7231	Fork (low and reverse gear shifter)	1	9L,9H,OL,OH,LL,1H	49-51
8L-7233-A	Sleeve (transmission interlock)- 1.287" long	1	9L,9H,OL,OH,LL,1H	49-51
8L-7233-B	Sleeve (transmission interlock)- 1.291" long	1	9L,9H,OL,OH,LL,1H	49-51
8L-7233-C	Sleeve (transmission interlock)- 1.295" long	1	9L,9H,OL,OH,LL,1H	49-51
8L-7233-D	Sleeve (transmission interlock)- 1.299" long	1	9L,9H,OL,OH,LL,1H	49-51
8L-7234	Spring (transmission mesh lock)	1	9L,9H,OL,OH,LL,1H	49-51
8L-7235	Pin (gear shifter interlock)	1	9L,9H,OL,OH,LL,1H	49-51
353075-S	Ball (Steel)-3/8" diameter	2	9L,9H,OL,OH,LL,1H	49-51
8L-7280-B	Cam and shaft assy (transmission high and intermediate shift)	1	9L,9H,OL,OH,LL,1H	49-51
8L-7282-B	Cam and shaft assy (transmission low and reverse shift)	1	9L,9H,OL,OH,LL,1H	49-51
8L-7285-B	Lever assy (transmission high and intermediate shift)	1	9L,9H,OL,OH,LL,1H	49-51
8L-7290-B	Lever assy (trans. low and reverse shift)	1	9L,9H,OL,OH,LL,1H	49-51
34846-S2	Lockwasher-5/16"	2	9L,9H,OL,OH,LL,1H	49-51
33797-S2	Nut (hex)-5/16"-18	2	9L,9H,OL,OH,LL,1H	49-51
44722-S8	Washer (flat)-5/16"	2	9L,9H,OL,OH,LL,1H	49-51
8M-7325-B	Rod assy (trans. high and inter. gear shift)-17-15/16" overall length	1	9L,OL,LL	49-51
8H-7325-A	Rod assy (trans. high and inter. gear shift)-17-5/8" o/all length	1	9H,OH,1H	49-51
8M-7327	Rod assy (trans. low and reverse gear shift)-19-15/16" overall length	1	9L,OL,LL	49-51
8H-7327	Rod assy (trans. low and reverse gear shift)-19-1/8" o/all length	1	9H,OH,1H	49-51
72009-S	Cotter pin-3/32" x 5/8"	2	9L,9H,OL,OH,LL,1H	49-51
352358-S32	Pin (self locking)-9/32" x 61/64"	2	9L,9H,OL,OH,LL,1H	49-51
34746-S7	Washer (flat)-5/16"	2	9L,9H,OL,OH,LL,1H	49-51
351341-S7	Washer (flat spring)-21/64" I.D. x 5/8" O.D.	2	9L,9H,OL,OH,LL,1H	49-51
8M-7353	Sleeve (trans. gear shift rod adj.)	2	9L,9H,OL,OH,LL,1H	49-51
8L-7354	Clevis (manual shift rod)	1	9L,9H,OL,OH,LL,1H	49-51
56H-7688	Seal assy (transmission shifter shaft oil)	2	9L,9H,OL,OH,LL,1H	49-51

Clutch

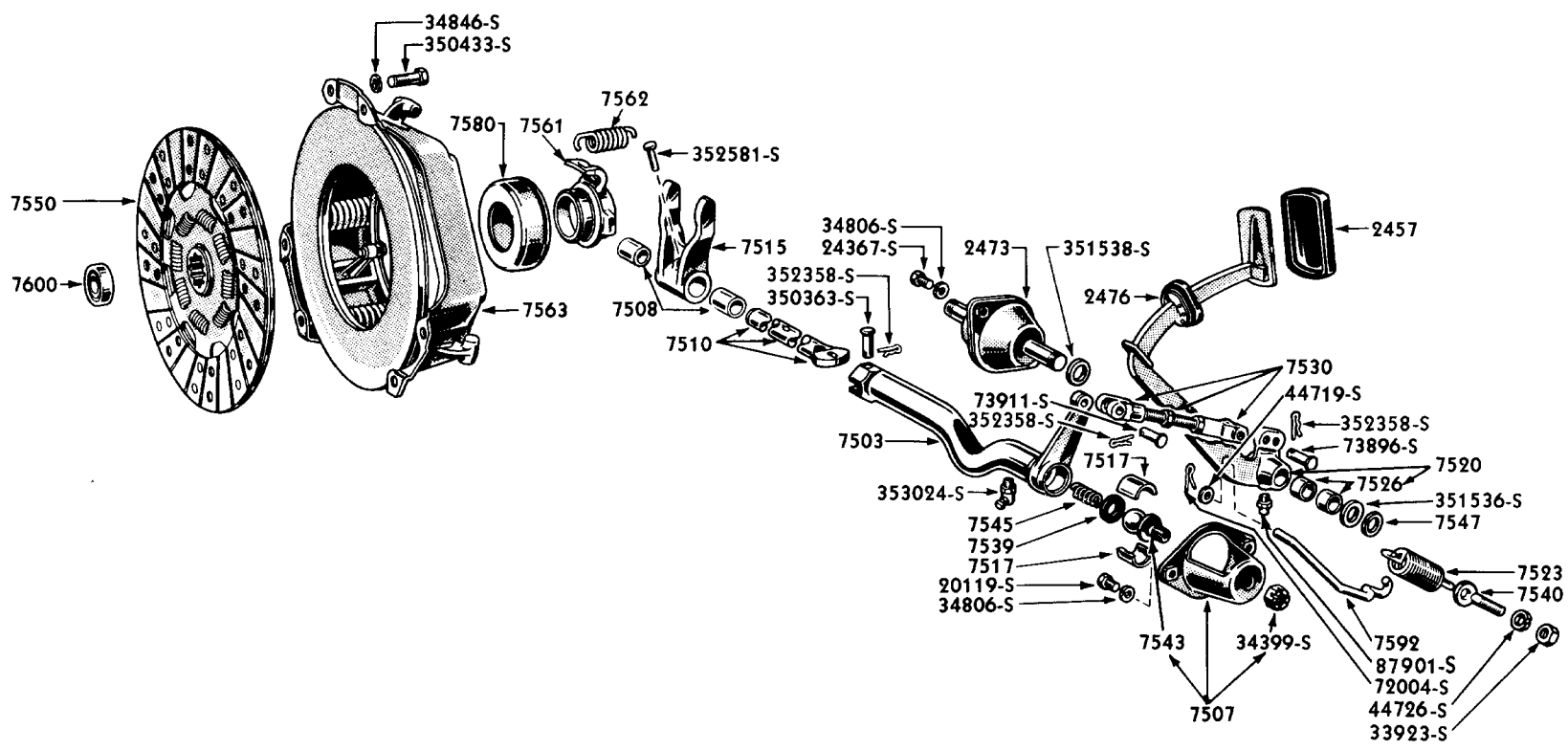

**CLUTCH AND RELATED PARTS**

Basic numbers only shown on illustration. Order by Part Numbers shown in list of parts.

PL-808

# Lincoln and Lincoln Cosmopolitan

## CHASSIS PARTS CATALOGUE

PART NUMBER	PART NAME	NO. REQ'D	MODEL	YEAR 19__
<b>Clutch—Continued</b>				
8M-2457	Pad (clutch and brake pedal)-Rubber	lor2	9L,9H,OL,OH,1L,1H	49-51
8M-2473	Shaft and bracket assy (clutch and brake pedal)	1	9L,9H,OL,OH,1L,1H	49-51
24367-S2	Bolt (hex-hd)-5/16"-24 x 7/8"-shaft and brkt. assy to frame	2	9L,9H,OL,OH,1L,1H	49-51
34806-S7	Lockwasher-5/16"-shaft and bracket assy to frame	2	9L,9H,OL,OH,1L,1H	49-51
351536-S7	Washer (plain)-3/4" I.D. x 1-1/8" O.D. x 3/32" thick-shaft and bracket assy to clutch and brake pedal	lor2	9L,9H,OL,OH,1L,1H	49-51
351538-S7	Washer (flat)-3/4" I.D. x 1-3/8" O.D. x 3/32" thick-shaft and bracket assy to clutch and brake pedal	lor2	9L,9H,OL,OH,1L,1H	49-51
8M-2476	Weatherseal assy (clutch and brake pedal)	lor2	9L,9H,OL,OH,1L,1H	49-51
8M 7503-B	Shaft (clutch release equalizer)	1	9L,9H,OL,OH,1L,1H	49-51
350363-S7	Clevis pin-1/2" x 1-15/32"-equalizer shaft to clutch release shaft	1	9L,9H,OL,OH,1L,1H	49-51
87901-S8	Fitting (lubricator)-1/8"-check valve type-for clutch release equalizer shaft	1	9L,9H,OL,OH,1L,1H	49-51
352358-S	Pin (self locking)-9/32" x 61/64"-equalizer shaft to clutch release shaft	1	9L,9H,OL,OH,1L,1H	49-51
8M 7507-A	NS Bracket and ball stud assy (clutch release equalizer shaft)-oval type design-repl. by 8M-7507-B	1	9L,9H	49
8M 7507-B	Bracket and ball stud assy (clutch release equalizer shaft)-oblong design	1	9L,9H,OL,OH,1L,1H	49-51
20019-S7	Bolt (hex-hd)-5/16"-24 x 9/16"-equalizer shaft brkt. to frame	2	9L,9H,OL,OH,1L,1H	49-51
34806-S7	Lockwasher-5/16"-equalizer shaft brkt. to frame	2	9L,9H,OL,OH,1L,1H	49-51
51A 7508	Bushing (clutch release shaft)-use on cars not equipped with lubricator fittings for clutch release shaft-1-1/4" long	2	9L,9H	49
8M 7508	Bushing (clutch release shaft)-use on cars equipped with lubricator fittings for clutch release shaft -1-3/8" long	2	9L,9H,OL,OH,1L,1H	49-51
01A 7510	Shaft (clutch release bearing)	1	9L,9H,OL,OH,1L,1H	49-51
5EH 7515	Fork (clutch release shaft)	1	9L,9H,OL,OH,1L,1H	49-51
352581-S7	Pin (flat-hd)-5/16" x 1-1/2"-fork to shaft	1	9L,9H,OL,OH,1L,1H	49-51
01A 7517	Socket (clutch release equalizer shaft ball)	2	9L,9H,OL,OH,1L,1H	49-51
48 7518	Cover (transmission inspection hole)	1	9L,9H,OL,OH,1L,1H	49-51
26148-S	Screw (rd-hd)-5/16"-18 x 3/8"-trans. inspection hole cover	2	9L,9H,OL,OH,1L,1H	49-51

# Lincoln and Lincoln Cosmopolitan

## CHASSIS PARTS CATALOGUE

PART NUMBER	PART NAME	NO. REQ'D	MODEL	YEAR 19
<b>Clutch—Continued</b>				
8M 7520-C1	Pedal & bushing assy (clutch)-pressed Steel type	1	9L,9H,0L,0H	49-50
8M 7520-C2	Pedal & bushing assy (clutch)-forging type-two 5/16" adjustment holes are approximately 1/2" apart from center to center	1	9L,9H,0L,0H	49-50
8M 7520-D	Pedal & bushing assy (clutch)-forging type-two 5/16" adjustment holes are approximately 7/8" apart from center to center	1	9L,9H,0L,0H,1L,1H	49-51
	87901-S8 Fitting (lubricator)-1/8"-straight	1	9L,9H,0L,0H,1L,1H	49-51
91A 7523	Spring (brake pedal retracting)-19 coils-close wound-5-25/64" long	1	9L,0L,1L	49-51
	8H-2456 Spring (brake pedal retracting)-19 to 20 coils-close wound-7" long	1	9H,0H,1H	49-51
8M 7523	Spring (clutch pedal retracting)-13 coils-close wound-3-41/64" long	1	9L,9H,0L,0H,1L,1H	49-51
01A 7526-A	Bushing (clutch pedal)-11/16" long	2	9L,9H,0L,0H,1L,1H	49-51
01A 7526-A	Bushing (brake pedal)-11/16" long	2	9L,9H,0L,0H,1L,1H	49-51
8H 7530-B	Rod assy (clutch pedal to release arm)-6-1/2" long	1	9H,0H,1H	49-51
8L 7530	Rod assy (clutch pedal to release arm)-5-25/64" long	1	9L,0L,1L	49-51
	73911-S7 Clevis pin-5/16" x 1-1/16"-clutch pedal release arm to equalizer arm	1	9L,9H,0L,0H,1L,1H	49-51
	73896-S7 Clevis pin-5/16" x 15/16"-clutch pedal release rod assy to clutch pedal assy	1	9L,9H,0L,0H,1L,1H	49-51
	352358-S Pin (self locking)-9/32" x 61/64"-clutch pedal release arm rod assy to equalizer arm	1	9L,9H,0L,0H,1L,1H	49-51
	352358-S Pin (self locking)-9/32" x 61/64"-clutch pedal release rod assy to clutch pedal assy	1	9L,9H,0L,0H,1L,1H	49-51
B 7533-B	Pin (brake pedal clevis)-1-7/16" long	1	9L,9H,0L,0H,1L,1H	49-51
01A 7539-A	Washer (clutch release equalizer shaft)-37/64" I.D. x 15/16" O.D.	1	9L,9H,0L,0H,1L,1H	49-51
8M 7540-A	Retainer (clutch pedal retracting spring)-3/8"-24 thread-when replacing with 8M-7540-B also use (1) 33798-S8, (1) 33923-S7 and (1) 44722-S8	1	9L,9H,0L,0H	49-50
	33729-S7 Nut (hex check)-3/8"-24 used with 8M-7540-A	1	9L,9H,0L,0H	49-50
	33800-S8 Nut (hex)-3/8"-24-used with 8M-7540-A	1	9L,9H,0L,0H	49-50
	44726-S8 Washer (flat)-3/8"-used with 8M-7540-A	1	9L,9H,0L,0H	49-50
8M 7540-B	Retainer (clutch pedal retracting spring)-5/16"-24 thread	1	9L,9H,0L,0H,1L,1H	49-51
	33798-S8 Nut (hex)-5/16"-24-used with 8M-7540-B	1	9L,9H,0L,0H,1L,1H	49-51
	33923-S7 Nut (hex check)-5/16"-24-used with 8M-7540-B	1	9L,9H,0L,0H,1L,1H	49-51
	44722-S8 Washer (flat)-5/16"-used with 8M-7540-B	1	9L,9H,0L,0H,1L,1H	49-51

# Lincoln and Lincoln Cosmopolitan

## CHASSIS PARTS CATALOGUE

PART NUMBER	CL	PART NAME	NO. REQ'D	MODEL	YEAR
<b>Clutch—Continued</b>					
8M 7543		Ball end (clutch release equalizer shaft)	1	9L, 9H, 0L, 0H, 1L, 1H	49-51
		34399-S8 Locknut (hex)-1/2"-20-ball end to bracket and nut assy	1	9L, 9H, 0L, 0H, 1L, 1H	49-51
01A 7545		Spring (clutch release equalizer shaft)-10 coils-1-45/64" long	1	9L, 9H, 0L, 0H, 1L, 1H	49-51
01A 7547		Retainer (clutch & brake pedal)-43/64" I.D.	lor2	9L, 9H, 0L, 0H, 1L, 1H	49-51
8EL 7550		Disc assy (clutch)	1	9L, 9H, 0L, 0H, 1L, 1H	49-51
48 7561		Hub (clutch release bearing)	1	9L, 9H, 0L, 0H, 1L, 1H	49-51
48 7562		Spring (clutch release bearing)-11 coils-close wound 1-7/16" long	1	9L, 9H, 0L, 0H, 1L, 1H	49-51
8EL 7563		Plate & cover assy (clutch pressure)	1	9L, 9H, 0L, 0H, 1L, 1H	49-51
		350433-S Bolt (hex-hd)-5/16"-18 x 49/64"-plate and cover assy to flywheel	6	9L, 9H, 0L, 0H, 1L, 1H	49-51
		34846-S2 Lockwasher-5/16"-plate & cover assy to flywheel	6	9L, 9H, 0L, 0H, 1L, 1H	49-51
8M 7568-A	NS	Bracket and nut assy (clutch release equalizer shaft)-replaced by 8M-7507-A	1	9L, 9H	49
78 7580-A		Bearing assy (clutch release)-3-1/2" O.D.	1	9L, 9H, 0L, 0H, 1L, 1H	49-51
8M 7592		Link (clutch pedal retracting spring)	1	9L, 9H, 0L, 0H, 1L, 1H	49-51
		72004-S7 Cotter pin-3/32" x 1/2"-link to clutch pedal	1	9L, 9H, 0L, 0H, 1L, 1H	49-51
		44719-S8 Washer (flat)-1/4"-link to clutch pedal	1	9L, 9H, 0L, 0H, 1L, 1H	49-51
B 7600-A		Bearing (clutch pilot)-Ball type-.6689"/.6693" I.D. x 1.5743"/1.5748" O.D. x .4674"/.4724" thick	1	9L, 9H, 0L, 0H, 1L, 1H	49-51
8L 7622	NS	Gasket (trans. to flywheel housing)-not replaced	1	9L, 9H, 0L, 0H, 1L, 1H	49-51
8L 7650-A		Extension, bearing and seal assy (transmission)	1	9L, 9H, 0L, 0H, 1L, 1H	49-51
8L 7650-B		Housing assy (transmission overdrive)	1	9L, 9H, 0L, 0H, 1L, 1H	49-51
8L 7650-C		Extension assy (transmission)	1	9L, 9H, 0L, 0H	49-50
OL 7650		Extension assy (trans.)-may be used in place of 8L-7650-C by also using OL-77133	1	0L, 0H, 1L, 1H	50-51
		24388-S8 Bolt (hex head)-3/8"-16 x 1"-extension assy to trans. case	5	9L, 9H, 0L, 0H, 1L, 1H	49-51
		34807-S2 Lockwasher-3/8"	5	9L, 9H, 0L, 0H, 1L, 1H	49-51
8L 7652	NS	Shaft and ring gear assy (trans. overdrive main)-replaced by (1) 8A-7025, (1) 8L-7064-A, B or C, (2) 8L-7064-A, (1) 8L-7653, (1) 8L-7054-A, B or C, (1) 8L-7749, (1) 8L-17285, (1) 74172-S	1	9L, 9H, 0L, 0H, 1L, 1H	49-51
8L 7653		Gear (transmission overdrive ring)-4-7/32" I.D. x 5-5/32" O.D. x 1-1/2" thick-52 teeth	1	9L, 9H, 0L, 0H, 1L, 1H	49-51

+ Used with HYDRA-MATIC transmission

++ Not used with HYDRA-MATIC transmission

# Lincoln and Lincoln Cosmopolitan

## CHASSIS PARTS CATALOGUE

PART NUMBER	PART NAME	NO. REQ'D	MODEL	YEAR 19__
<b>Clutch—Continued</b>				
8L 7654-A	Ring (trans. overdrive ring gear snap)-.056"/.054" thick	as reqd	9L, 9H, 0L, 0H, 1L, 1H	49-51
8L 7654-B	Ring (trans. overdrive ring gear snap)-.058"/.056" thick	as reqd	9L, 9H, 0L, 0H, 1L, 1H	49-51
8L 7654-C	Ring (trans. overdrive ring gear snap)-.060"/.058" thick	as reqd	9L, 9H, 0L, 0H, 1L, 1H	49-51
8M 7656	Snap ring (trans. overdrive main shaft bearing)	1	9L, 9H, 0L, 0H, 1L, 1H	49-51
✚8L 7657-A	Seal assy (transmission main shaft oil)	1	9L, 9H, 0L, 0H, 1L, 1H	49-51
✚8L 7657-B	Seal assy (transmission extension rear oil)	1	9L, 9H, 0L, 0H, 1L, 1H	49-51
8L 7660	Adapter (transmission overdrive)	1	9L, 9H, 0L, 0H, 1L, 1H	49-51
8L 7661	Gasket (transmission overdrive housing adapter)	1	9L, 9H, 0L, 0H, 1L, 1H	49-51
8L 7662	Ring and gear plate assy (trans. overdrive balk)	1	9L, 9H, 0L, 0H, 1L, 1H	49-51
56H 7665	Plate and trough assy (trans. overdrive cover)	1	9L, 9H, 0L, 0H, 1L, 1H	49-51
16H 7666-A	Snap ring (trans. O/Drive cover plate)-.062" thick	1	9L, 9H, 0L, 0H, 1L, 1H	49-51
16H 7666-B	Snap ring (trans. O/Drive cover plate)-.070" thick	1	9L, 9H, 0L, 0H, 1L, 1H	49-51
16H 7666-C	Snap ring (trans. O/Drive cover plate)-.066" thick	1	9L, 9H, 0L, 0H, 1L, 1H	49-51
8L 7668	Baffle (transmission O/Drive main shaft oil)	1	9L, 9H, 0L, 0H, 1L, 1H	49-51
8L 7670	Gear assy (transmission overdrive sun)	1	9L, 9H, 0L, 0H, 1L, 1H	49-51
8L 7672-A	Ring (trans. overdrive pinion cage to main shaft) -.062" thick	1	9L, 9H, 0L, 0H, 1L, 1H	49-51
8L 7672-B	Ring (trans. overdrive pinion cage to main shaft) -.068" thick	1	9L, 9H, 0L, 0H, 1L, 1H	49-51
8L 7672-C	Ring (trans. overdrive pinion cage to main shaft) -.074" thick	1	9L, 9H, 0L, 0H, 1L, 1H	49-51
8L 7673	Cage assy (transmission overdrive pinion)	1	9L, 9H, 0L, 0H, 1L, 1H	49-51
8L 7675	Cam, roller & cage assy (trans. O/Drive free wheel)	1	9L, 9H, 0L, 0H, 1L, 1H	49-51
8L 7680	Fork and rail assy (transmission overdrive shift)	1	9L, 9H, 0L, 0H, 1L, 1H	49-51
16H 7685	Spring (transmission overdrive retractor)-15 coils-2-3/4" long	1	9L, 9H, 0L, 0H, 1L, 1H	49-51
8L 7686	Shaft (transmission overdrive control)-2-21/32" long	1	9L, 9H, 0L, 0H, 1L, 1H	49-51
56H 7688	Seal assy (transmission shifter shaft oil)	2	9L, 9H, 0L, 0H, 1L, 1H	49-51
56H 7688	Seal assy (transmission overdrive shifter shaft oil)	1	9L, 9H, 0L, 0H, 1L, 1H	49-51
8M 7689	Lever (transmission overdrive control)	1	9L, 9H, 0L, 0H, 1L, 1H	49-51
8L 7690	Pawl (transmission overdrive stationary gear)	1	9L, 9H, 0L, 0H, 1L, 1H	49-51
✚8L 7692	Shield (transmission extension rear oil seal)	1	9L, 9H, 0L, 0H, 1L, 1H	49-51
26H 7693	Seal (transmission overdrive pawl operating rod oil)	1	9L, 9H, 0L, 0H, 1L, 1H	49-51
8L 7696	Guide (transmission overdrive shift rail)	1	9L, 9H, 0L, 0H, 1L, 1H	49-51

✚ Used with HYDRA-MATIC transmission

✚✚ Not used with HYDRA-MATIC transmission

# Lincoln and Lincoln Cosmopolitan

## CHASSIS PARTS CATALOGUE

PART NUMBER	CLASS	PART NAME	NO. REQ'D	MODEL	YEAR 19
8L 7697-B		Bearing (transmission main shaft)-rear	2	9L,9H,OL,OH,1L,1H	49-51
8EL 7713		Clip (trans. overdrive control cable support at engine)	1	9L,9H,OL,OH,1L,1H	49-51
8L 7728-A		Washer (transmission reverse idler gear thrust)- 7/8" I.D. x 1-49/64" O.D.	2	9L,9H,OL,OH,1L,1H	49-51
8L 7749		Shaft & ring assy (transmission overdrive main)	1	9L,9H,OL,OH,1L,1H	49-51
*OL 7770		Pan assy (transmission control linkage splash)	1	9L,9H,OL,OH,1L,1H	49-51
		*40921-S8 Screw (self-tapping)-1/4"-20 x 1/2"-splash pan to frame "K" bar	4	9L,9H,OL,OH,1L,1H	49-51
*OL 7772-D		Seal (trans. control linkage splash pan)-Rubber- 11-19/64" long x 2-35/64" wide-cut to length	as reqd	9L,9H,OL,OH,1L,1H	49-51
8M 7777		Cover (transmission overdrive main shaft bearing)	1	9L,9H,OL,OH,1L,1H	49-51
8M 7778		Gasket (transmission overdrive main shaft cover)	1	9L,9H,OL,OH,1L,1H	49-51
*8L 7910		Cover assy (transmission torus)	1	9L,9H,OL,OH,1L,1H	49-51
*8L 7912		Torus assy (transmission driven)	1	9L,9H,OL,OH,1L,1H	49-51
*8L 7914		Torus assy (transmission assy driving)	1	9L,9H,OL,OH,1L,1H	49-51
*8L 7916		Valve (transmission torus check)	1	9L,9H,OL,OH,1L,1H	49-51
*8L 7917		Snap ring (torus retaining)	5	9L,9H,OL,OH,1L,1H	49-51
*8L 7919		Lever (transmission throttle control outer)	1	9L,9H,OL,OH,1L,1H	49-51
		*8L-9737 Spring (accelerator pedal retracting)-to provide tension from trans. throttle control outer lever (8L-7919) to frame	1	9L,9H,OL,OH,1L,1H	49-51
		*24385-S2 Bolt (hex-hd)-1/4"-28 x 1"- outer throttle control lever	1	9L,9H,OL,OH,1L,1H	49-51
*8L 7920		Plug (hex head)-1/8" pipe-transmission torus cover	1	9L,9H,OL,OH,1L,1H	49-51
*8L 7921		Retainer (transmission torus check valve)	1	9L,9H,OL,OH,1L,1H	49-51
		*20001-S7 Bolt (hex-hd)-1/4"-28 x 3/8"- trans. torus check valve ret.	2	9L,9H,OL,OH,1L,1H	49-51
*8L 7922		Spring (transmission torus check valve)-1-37/64" I.D. x 3-17/32" free length	1	9L,9H,OL,OH,1L,1H	49-51
*8L 7923		Nut (transmission main shaft)-hex-7/8"-16	1	9L,9H,OL,OH,1L,1H	49-51
*8L 7924		Washer (transmission main shaft nut lock)-39/32" I.D. x 1-49/64" O.D.	1	9L,9H,OL,OH,1L,1H	49-51
*8L 7927		Ring (trans. driven torus retaining)-7/8" I.D. x 1-3/8" O.D. x 1/8" thick	1	9L,9H,OL,OH,1L,1H	49-51
*8L 7938		Bearing (transmission pilot)-Bronze-19/32" I.D. x 1-3/32" O.D. x 3/4" long	1	9L,9H,OL,OH,1L,1H	49-51
*8L 7942		Retainer (trans. pilot bearing)-Steel-39/64" I.D. x 1-37/64" O.D. x 7/32" deep	1	9L,9H,OL,OH,1L,1H	49-51
*8L 7943		Bolt (hex-hd)-5/16"-24 x 59/64" long-torus cover to flywheel assy	30	9L,9H,OL,OH,1L,1H	49-51
		*34806-S7 Lockwasher-5/16"-torus cover to flywheel assy	30	9L,9H,OL,OH,1L,1H	49-51
*8L 7945		Gasket (flywheel to torus cover assy)-12-1/2" I.D. x 13-7/8" O.D.-Rubber Coated Fibre	1	9L,9H,OL,OH,1L,1H	49-51

\* Used with HYDRA-MATIC transmission

# Lincoln and Lincoln Cosmopolitan

## CHASSIS PARTS CATALOGUE

### Radiator

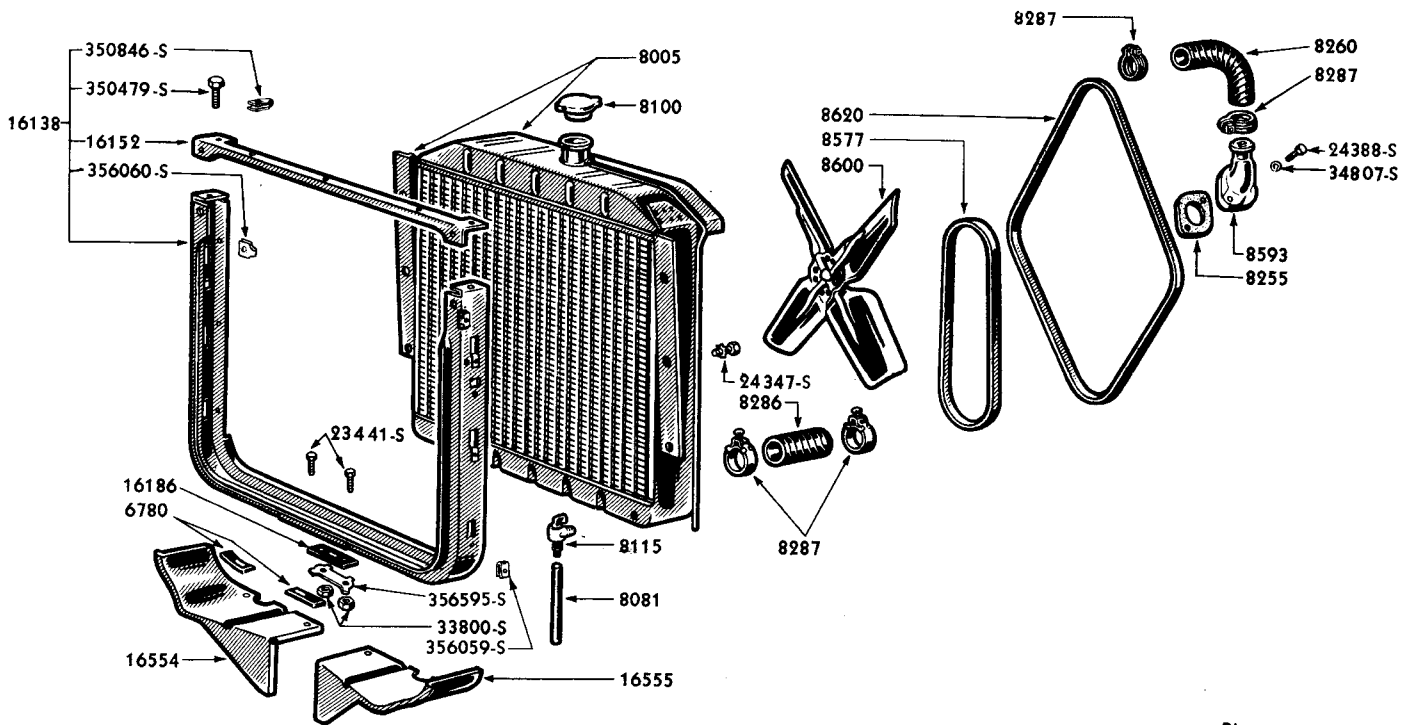

PL-555

### RADIATOR AND RELATED PARTS

Basic numbers only shown on illustration. Order by Part Numbers shown in list of parts.

PART NUMBER	QUANTITY	PART NAME	NO. REQ'D	MODEL	YEAR
8H-19546-A	MS	Rust inhibitor-pt. can-replaced by 8H-19546-B		9L,9H,OL,OH,LL,LH	49-51
8H-19546-B		Rust inhibitor-case of (12) pt. cans		9L,9H,OL,OH,LL,LH	49-51
8L-19558-A	MS	Radiator Stop Leak-10 oz. can-replaced by 8L-19558-B		9L,9H,OL,OH,LL,LH	49-51
8L-19558-B		Radiator Stop Leak-case of (12) 10 oz. cans		9L,9H,OL,OH,LL,LH	49-51
8EH 8005-A		Radiator assy	1	9H,OH	49-50
OEH 8005		Radiator assy	1	9H,OH,LH	49-51
8EL 8005-A		Radiator assy	1	9L,OL	49-50
OEL 8005		Radiator assy	1	9L,OL,LL	49-51
		24347-S8 Bolt (hex head)-5/16"-24 x 3/4"	6	9L,9H,OL,OH,LL,LH	49-51
		34806-S7 Lockwasher-5/16"-radiator to radiator support	6	OL,OH,LL,LH	50-51
		357252-S2 Nut (cage)-5/16"-24-radiator to radiator support	6	9L,9H,OL,OH,LL,LH	49-51
8EL-8260		Hose (radiator)-upper-used with 8EH-8005-A & 8EL-8005-A	2	9L,9H,OL,OH	49-50
OEL-8260		Hose (radiator)-upper-R.H.-used with OEH-8005 & OEL-8005 Radiator assy	1	OL,OH,LL,LH	50-51



# Lincoln and Lincoln Cosmopolitan

## CHASSIS PARTS CATALOGUE

PART NUMBER	PART NAME	NO. REQ'D	MODEL	YEAR 19__
<b>Radiator—Continued</b>				
OEL-8261	Hose (radiator)-upper-L.H.-used with OEH-8005 & OEL-8005 Radiator assy	1	OL,OH,LL,LH	50-51
2LA-8286-A	Hose (radiator lower)	2	9L,9H,OL,OH,LL,LH	49-51
60-8287	Clamp assy (radiator upper hose)- 1-7/8" diameter	4	9L,9H,OL,OH,LL,LH	49-51
5EH-8287-A	Clamp assy (radiator lower hose)- 2-5/16"-dia.-hex head vertical screw-optional with 5EH-8287-B	4	9L,9H,OL,OH,LL,LH	49-51
5EH-8287-B	Clamp assy (radiator lower hose)- 2-5/32" dia.-fillister head horizontal screw-optional with 5EH-8287-A	4	9L,9H,OL,OH,LL,LH	49-51
8H 8046-C	Bracket (radiator support to fender apron)-RH	1	9L,9H,OL,OH,LL,LH	49-51
8H 8047-C	Bracket (radiator support to fender apron)-LH	1	9L,9H,OL,OH,LL,LH	49-51
43263-S8	Screw & lockwasher assy (hex head)-1/4"-20 x 5/8"	4	9L,9H,OL,OH,LL,LH	49-51
43264-S8	Screw & washer (hex head)-5/16" -24 x 7/8"-bracket to radiator core support	2	OL,OH,LL,LH	50-51
44724-S8	Washer (flat)-5/16"-bracket to apron and radiator support	2	OL,OH,LL,LH	50-51
8M 8081	Extension (cylinder block drain cock)-Rubber Hose	1	9L,9H,OL,OH,LL,LH	49-51
26H 8100-B	Cap assy (radiator)-used with 8EH-8005-A & 8EL-8005-A Radiator assy	1	9L,9H,OL,OH	49-50
OL-8100-A	Cap assy (radiator)-used with OEH-8005 & OEL-8005 Radiator assy	1	OL,OH,LL,LH	50-51
9N 8115-A	Cock assy (radiator drain)-straight type	2	9L,9H,OL,OH,LL,LH	49-51
8CM 8115-A	Cock assy (radiator drain)-tee type	1	9L,9H,OL,OH,LL,LH	49-51

## Radiator Grille

7EH 8150	Grille (radiator)-RH-side lower-28-15/16" length	1	9L,9H	49
OL 8150	Bar (radiator grille)-lower-RH-21-27/32" length	1	OL,OH	50
*LL 8150-A	Bar (radiator grille)-lower-RH-16-35/64" length- Chrome Plated Cold Rolled Steel-alternate with LL-8150-C	1	LL,LH	51
*LL 8150-C	Bar (radiator grille)-lower-RH-16-35/64" length- Chrome Flash Rustless Steel-alternate with LL-8150-A	1	LL,LH	51
7EH 8151	Grille (radiator)-LH-side lower-28-15/16" length	1	9L,9H	49
OL 8151	Bar (radiator grille)-lower-LH-21-27/32" length	1	OL,OH	50
*LL 8151-A	Bar (radiator grille)-lower-LH-16-35/64" length- Chrome Plated Cold Rolled Steel-alternate with LL-8151-C	1	LL,LH	51
*LL 8151-C	Bar (radiator grille)-lower-LH-16-35/64" length- Chrome Flash Rustless Steel-alternate with LL-8151-A	1	LL,LH	51

\* Alternate material due to Material Emergency

# Lincoln and Lincoln Cosmopolitan

## CHASSIS PARTS CATALOGUE

### Radiator Grille-Continued

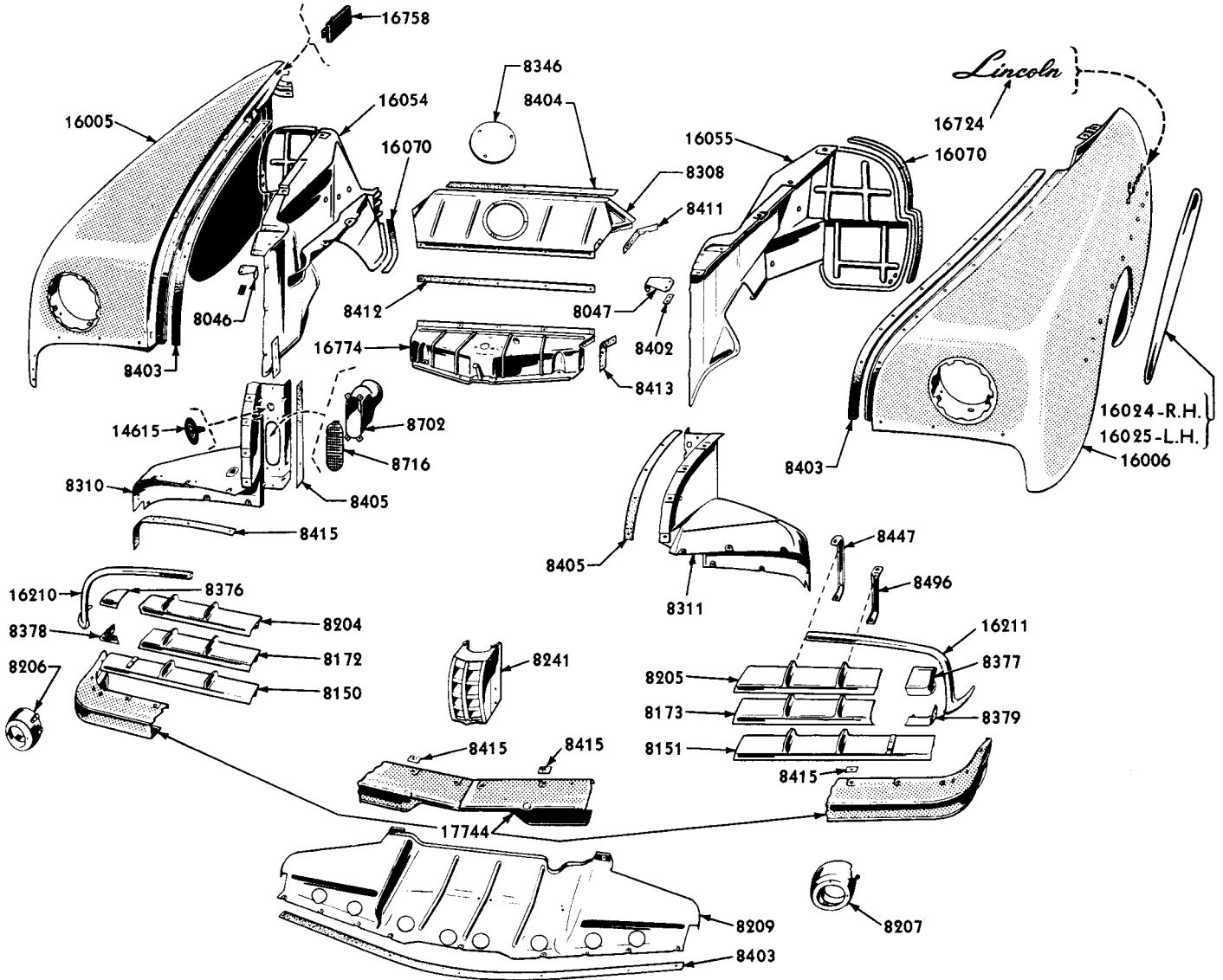

PL-203

### LINCOLN (1949)

Basic numbers only shown on illustration. Order by Part Numbers shown in list of parts.

PART NUMBER	QTY	PART NAME	NO. REQ'D	MODEL	YEAR
24324-S7-8		Bolt (hex head)-1/4"-20 x 5/8"-bar to grille bar extension	6	1L,1H	51
43261-S7		Bolt & lockwasher assy (hex head-1/4"-20 x 7/8"-bar to center grille bar	2	1L,1H	51
355296-S7		Bolt and lockwasher assy (hex head)-1/4"-20 x 1/2"	3	9L,9H	49
34805-S8		Lockwasher-1/4"-bar to grille bar extension	6	1L,1H	51

# Lincoln and Lincoln Cosmopolitan

## CHASSIS PARTS CATALOGUE

### Radiator Grille—Continued

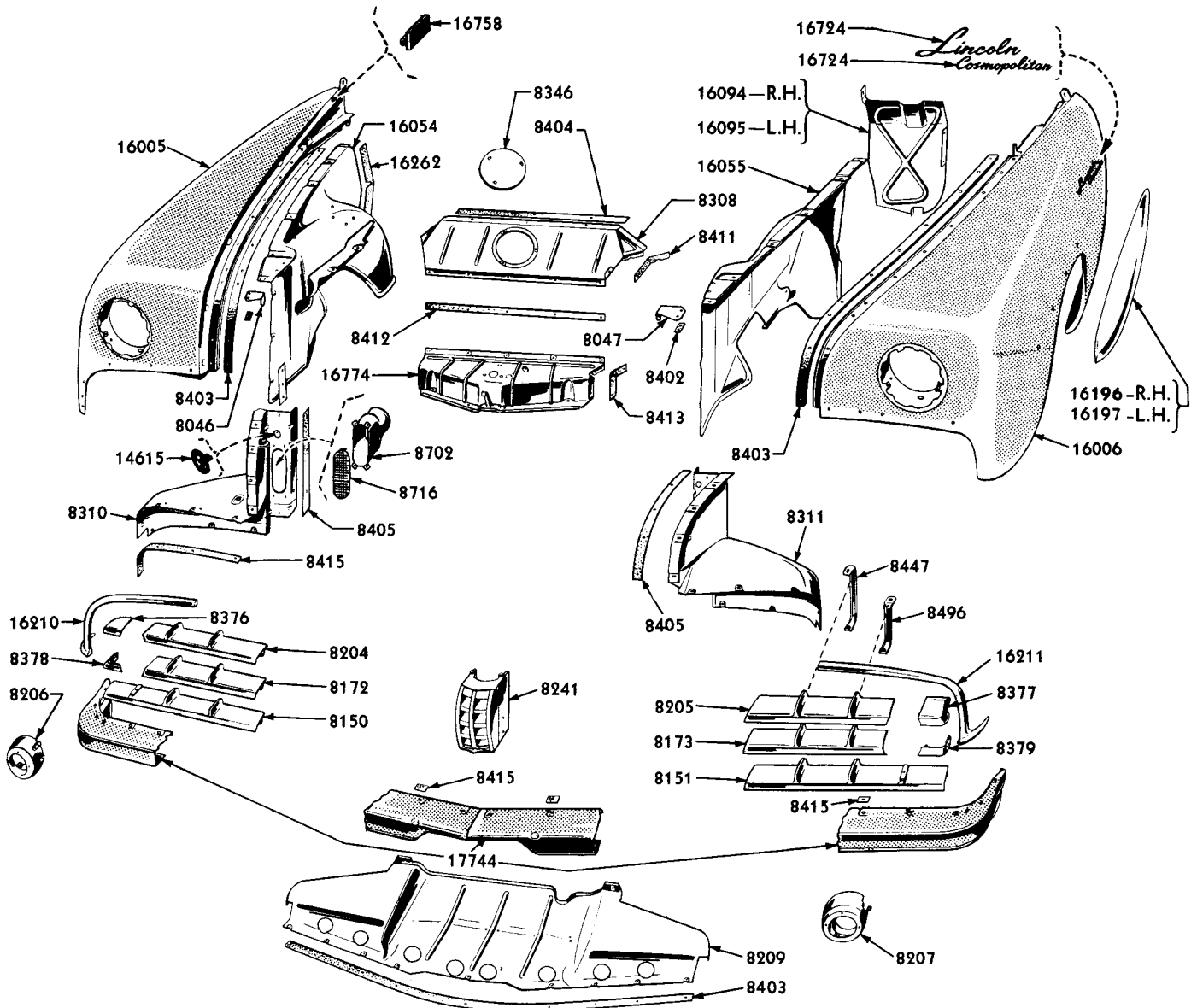

PL-183

### LINCOLN COSMOPOLITAN (1949)

Basic numbers only shown on illustration. Order by Part Numbers shown in list of parts.

PART NUMBER	QUANTITY	PART NAME	NO. REQ'D	MODEL	YEAR 19__
33795-S7		Nut (hex)-1/4"-20-bar to stone deflector	2	1L,1H	51
33795-S7		Nut (hex)-1/4"-20-bar to grille bar extension	6	1L,1H	51
357227-S		Nut (caged)-1/4"-20-bar to center grille bar	2	1L,1H	51
42906-S8		Screw & lockwasher assy (hex head)-1/4"-20 x 3/4"-bar to stone deflector	2	1L,1H	51

# Lincoln and Lincoln Cosmopolitan

## CHASSIS PARTS CATALOGUE

PART NUMBER	PART NAME	NO. REQ'D	MODEL	YEAR 19__
<b>Radiator Grille-Continued</b>				
	357225-S8 Screw & washer (hex head)-1/4" -20 x 1/2"-bar to inner grille support	2	OL,OH	50
	357225-S8 Screw & washer (hex head)-1/4" -20 x 1/2"-bar to vertical bar	4	OL,OH	50
	44719-S8 Washer (flat)-1/4"-bar to extension bar	6	1L,1H	51
	44720-S8 Washer (flat)-1/4"-bar to to center grille bar	2	1L,1H	51
	44720-S8 Washer (flat)-1/4"-bar to stone deflector	4	1L,1H	51
7EH 8162	Latch assy (hood)	1	9L,9H,OL,OH,1L,1H	49-51
	34940-S2 Lockwasher (external tooth)- 1/4"-latch to hood lock support	3	9L,9H,OL,OH,1L,1H	49-51
	33795-S7 Nut (hex)-1/4"-20-latch to hood lock support	3	9L,9H,OL,OH,1L,1H	49-51
	34390-S7 Nut (lock)-1/4"-20-latch to hood lock support	3	9L,9H,OL,OH,1L,1H	49-51
	39072-S2 Screw (pan head)-1/4"-20 x 3/4"-latch to hood lock support	3	9L,9H,OL,OH,1L,1H	49-51
	44719-S8 Washer (flat)-1/4"-latch to hood lock support	3	9L,9H,OL,OH,1L,1H	49-51
7EH 8172	Grille (radiator side)-RH-intermediate	1	9L,9H	49
7EH 8173	Grille (radiator side)-LH-intermediate	1	9L,9H	49
1L 8179	Support (radiator grille)-center	1	1L,1H	51
	33795-S7 Nut (hex)-1/4"-20-support to hood lock support and grille bar	1	1L,1H	51
	42906-S8 Screw and washer (hex head)- 1/4"-20 x 3/4"-support to upper grille bar	1	1L,1H	51
	357225-S8 Screw and washer (hex head)- 1/4"-20 x 1/2"-support to lower grille bar	1	1L,1H	51
	44720-S8 Washer (flat)-1/4"-support to upper grille bar	2	1L,1H	51
7EH 8204	Grille (radiator)-RH-upper	1	9L,9H	49
OL 8204	Bar (radiator grille)-upper	1	OL,OH	50
1L 8204	Bar (radiator grille)-upper	1	1L,1H	51
	43264-S8 Bolt and lockwasher (hex-hd)- 5/16"-24 x 7/8"-bar to fender	2	1L,1H	51
	357257-S2 Retainer (nut)-5/16"-24-bar to front fender	2	1L,1H	51
	357225-S8 Screw & washer (hex head)-1/4" -20 x 1/2"-bar to upper grille extension	4	OL,OH	50
	357225-S8 Screw and washer (hex head)- 1/4"-20 x 1/2"-bar to front fender	4	OL,OH,1L,1H	50-51

# Lincoln and Lincoln Cosmopolitan

## CHASSIS PARTS CATALOGUE

PART NUMBER	PART NAME	NO. REQ'D	MODEL	YEAR 19__
<b>Radiator Grille—Continued</b>				
	44722-S8 Washer (flat)-5/16"-bar to front fender	2	1L,1H	51
	356381-S7 Washer (flat)-27/64" I.D. x 13/16" O.D.-bar to front fender	2	OL,OH,1L,1H	50-51
7EH 8205	Grille (radiator)-LH-upper	1	9L,9H	49
7EH 8206-B	Housing (grille roadlamp)-RH	1	9L,9H	49
7EH 8207-B	Housing (grille roadlamp)-LH	1	9L,9H	49
	352301-S8 Screw & lockwasher assy (pan head)-1/4"-20 x 3/4"	4	9L,9H	49
8H 8209	Shield assy (radiator splash)	1	9L,9H	49
OL 8209	Shield assy (radiator splash)	1	OL,OH	50
1L 8209	Shield assy (radiator splash)	1	1L,1H	51
	8L-16554 Shield (radiator support to front cross member splash)-RH	1	9L,9H,OL,OH,1L,1H	49-51
	8L-16555 Shield (radiator support to front cross member splash)-LH	1	9L,9H,OL,OH,1L,1H	49-51
	357254-S2 Nut (retainer)-1/4"-28-shield to side air deflector	2	9L,9H,OL,OH,1L,1H	49-51
	357254-S2 Nut (retainer)-1/4"-28-shield to front stone deflector	9	9L,9H,OL,OH,1L,1H	49-51
	357254-S2 Nut (retainer)-1/4"-28-shield to radiator air deflector	6	9L,9H,OL,OH,1L,1H	49-51
	42904-S8 Screw and washer (hex head)-1/4"-28 x 5/8"-shield to air deflector	2or6	9L,9H,OL,OH,1L,1H	49-51
	42904-S8 Screw and washer (hex head)-1/4"-28 x 5/8"-shield to front stone deflector	9	9L,9H,OL,OH,1L,1H	49-51
	42904-S8 Screw and washer (hex head)-1/4"-28 x 5/8"-shield to side air deflector	2	9L,9H,OL,OH,1L,1H	49-51
7EH 8216	Ornament (hood lower front)	1	9L,9H	49
	350057-S7 Screw & lockwasher assy (slotted hex-hd)-No. 10-24 x 7/16"-ornament to hood	6	9L,9H	49
8H 8219-B	Spacer (hood ornament)-round	10	9L,9H,OL,OH	49-50
8M 8219	Spacer (hood ornament)-square	2	1L,1H	51
OL 8230	Extension (radiator grille lower bar)-RH	1	OL,OH	50
1L 8230	Extension (radiator grille lower bar)-RH	1	1L,1H	51
OL 8231	Extension (radiator grille lower bar)-LH	1	OL,OH	50
1L 8231	Extension (radiator grille lower bar)-LH	1	1L,1H	51
	357225-S8 Screw and washer (hex head)-1/4"-20 x 1/2"-extension to front fender	6	OL,OH,1L,1H	50-51

# Lincoln and Lincoln Cosmopolitan

## CHASSIS PARTS CATALOGUE

### Radiator Grille-Continued

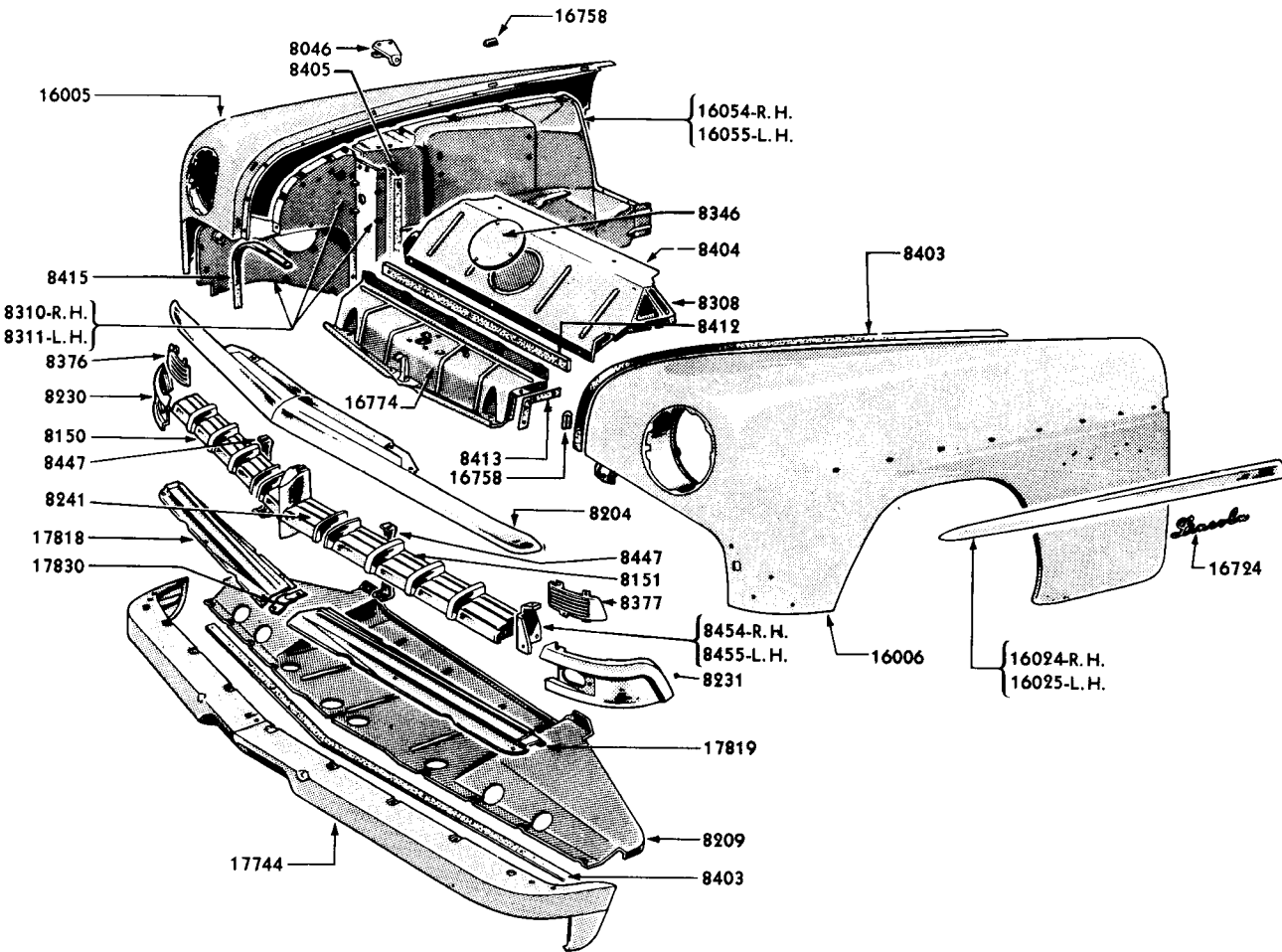

PL-388

### LINCOLN (1950)

Basic numbers only shown on illustration. Order by Part Numbers shown in list of parts.

PART NUMBER	QTY	PART NAME	NO. REQ'D	MODEL	YEAR
7EH 8241		Grille (radiator center)	1	9L,9H	49
OL 8241		Bar (radiator grille)-vertical	1	OL,OH	50
1L 8241		Bar (radiator grille lower)-center	1	1L,1H	51
		20384-S2 Bolt (hex head)-1/4"-20 x 1"-bar to stone deflector	1	9L,9H,OL,OH	49-50
		350212-S7 Bolt & lockwasher assy (hex-hd)-1/4"-20 x 5/8"	2	9L,9H	49
		34940-S2 Lockwasher-1/4"-bar to stone deflector	1	9L,9H,OL,OH	49-50
		33795-S7 Nut (hex)-1/4"-20-bar to stone deflector	1	9L,9H,OL,OH	49-50

# Lincoln and Lincoln Cosmopolitan

## CHASSIS PARTS CATALOGUE

### Radiator Grille—Continued

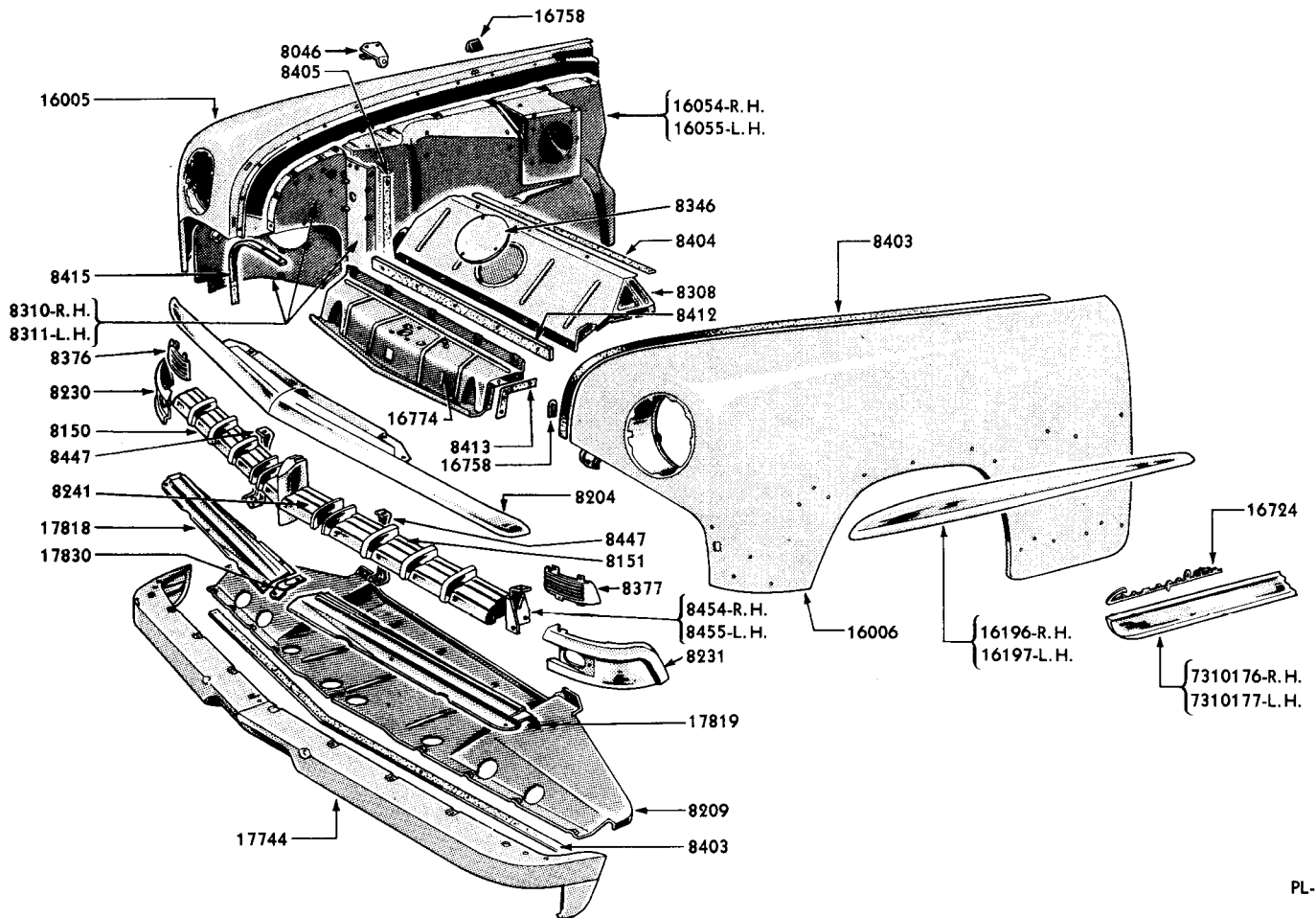

PL-374

### LINCOLN COSMOPOLITAN (1950)

Basic numbers only shown on illustration. Order by Part Numbers shown in list of parts.

PART NUMBER	CLASS	PART NAME	NO. REQ'D	MODEL	YEAR 19 ____
42906-88		Screw and washer (hex head)- 1/4"-20 x 3/4" bar to stone deflector	2	1L,1H	51
44720-88		Washer (flat)-1/4"-bar to stone deflector	2	0L,0H,1L,1H	50-51
3EL 8255-C		Gasket (water outlet connection)-2-9/64" I.D. hole	2	9L,9H,0L,0H,1L,1H	49-51
8EL 8260		Hose (radiator upper)-used with 8EL-8005-A and 8EH-8005-A Radiator assy	2	9L,9H,0L,0H	49-50
OEL 8260		Hose (radiator upper)-RH-used with OEH-8005 and OEL-8005 Radiator assy	1	0L,0H,1L,1H	50-51
OEL 8261		Hose (radiator upper)-LH-used with OEH-8005 and OEL-8005 Radiator assy	1	0L,0H,1L,1H	50-51
60-8287		Clamp assy (radiator upper hose)- 1-7/8" diameter	4	9L,9H,0L,0H,1L,1H	49-51

# Lincoln and Lincoln Cosmopolitan

## CHASSIS PARTS CATALOGUE

PART NUMBER	PART NAME	NO. REQ'D	MODEL	YEAR
<b>Radiator Grille-Continued</b>				
21A 8286-A	Hose (radiator lower)	2	9L 9H, OL, OH, 1L, 1H	49-51
	5EH-8287-A Clamp assy (radiator lower hose)- 2-5/16" dia.-hex head vertical screw-optional with 5EH-8287-B	4	9L, 9H, OL, OH, 1L, 1H	49-51
	5EH-8287-B Clamp assy (radiator lower hose)- 2-5/32" dia.-fillister head horizontal screw-optional with 5EH-8287-A	4	9L, 9H, OL, OH, 1L, 1H	49-51
B 8287-A	Clamp assy (neutral spring to steering column)- 2-1/8" diameter	1	9L, 9H	49
60 8287	Clamp assy (radiator upper hose)-1-7/8" diameter	4	9L, 9H, OL, OH, 1L, 1H	49-51
78 8287-A	NS Clamp assy (back up lamp)-2-7/32" diameter-serviced in 1H-18274-A and 1H-18274-B Kits	1	9L, 9H, OL, OH, 1L, 1H	49-51
91A 8287	Clamp assy (fuel tank filler hose)-2-9/32" diameter	2	9H, OH, 1H	49-51
11A 8287	Clamp assy (fuel tank filler hose)-2-39/64" diameter	2	9L, OL, 1L	49-51
5EH 8287-A	Clamp assy (radiator lower hose)-hex head vertical screw-optional with 5EH-8287-B	4	9L, 9H, OL, OH, 1L, 1H	49-51
5EH 8287-B	Clamp assy (radiator lower hose)-fillister head horizontal screw-optional with 5EH-8287-A	4	9L, 9H, OL, OH, 1L, 1H	49-51
	34141-S7 Nut (square)-No. 10-32	2	9H, OH	49-50
	27177-S7 Screw (round head)-No. 10-32 x 1-1/2"	2	9H, OH	49-50
7EH 8308-B	Panel (radiator air deflector)-upper	1	9H, OH, 1H	49-51
	43260-S8 Bolt & lockwasher assy (hex head)-1/4"-20 x 1/2"	3	9H, OH, 1H	49-51
8L 8308-A	Panel (radiator air deflector)-upper-bottom flange outer holes approximately 6-51/64" apart	1	9L, OL	49-50
8L 8308-B	Panel (radiator air deflector)-upper-bottom flange outer holes approximately 5-51/64" apart	1	9L, OL, 1L	49-51
	7EH-8346 Plate (radiator air deflector cover)-upper	1	9L, 9H, OL, OH, 1L, 1H	49-51
	357254-S2 Nut (retainer)-1/4"-28-panel to hood lock support plate	5	OL, OH, 1L, 1H	50-51
	42023-S7 Screw (hex-hd self tapping)- No. 14-10 x 3/4"	14	9L, 9H, OL, OH	49-50
	42023-S7 Screw (hex-hd)-No. 14-10 x 3/4" -panel to air deflector	2	1L, 1H	51
	42904-S8 Screw and washer (hex-hd)-1/4"- 28 x 5/8"-panel to apron and radiator support	3	OL, OH, 1L, 1H	50-51
	42904-S8 Screw and washer (hex-hd)-1/4"- 28 x 5/8"-panel to air defl.	2	1L, 1H	51
	42904-S8 Screw and washer (hex-hd)-1/4"- 28 x 5/8"-panel to hood lock support	5	OL, OH, 1L, 1H	50-51
	44719-S8 Washer (flat)-1/4"-panel to air deflector	2	1L, 1H	51
	44720-S8 Washer (flat)-1/4"	2	9L, 9H, OL, OH	49-50



# Lincoln and Lincoln Cosmopolitan

## CHASSIS PARTS CATALOGUE

PART NUMBER	PART NAME	NO. REQ'D	MODEL	YEAR 19__
<b>Radiator Grille—Continued</b>				
8H 8310-A	Deflector assy (radiator grille air)-RH	1	9L,9H	49
OL 8310	Deflector assy (radiator grille air)-RH	1	OL,OH	50
1L 8310	Deflector assy (radiator grille air)-RH	1	1L,1H	51
8H 8311-A	Deflector assy (radiator grille air)-LH	1	9L,9H	49
OL 8311	Deflector assy (radiator grille air)-LH	1	OL,OH	50
1L 8311	Deflector assy (radiator grille air)-LH	1	1L,1H	51
	353266-SA1 Clip (cowl wiring to air deflector)	1	9L,9H	49
	34129-S2 Nut (plain)-1/4"-20	8	OL,OH,1L,1H	50-51
	357254-S2 Nut (retainer)-1/4"-28-defl. to upper air deflector	2	OL,OH,1L,1H	50-51
	357257-S2 Retainer (nut)-5/16"-24-defl. to fender apron	6	1L,1H	51
	32853-S7 Screw (rd-hd self tap.)-No. 12 -11 x 3/8"-defl. to fender	2	9L,9H	49
	42023-S7 Screw (hex-hd)-No. 14-10 x 3/4" -deflector to front fender	6	1L,1H	51
	42904-S8 Screw and washer (hex-hd)-1/4"-28 x 5/8"-deflector to upper air deflector	2	OL,OH	50
	42904-S8 Screw and washer (hex-hd)-1/4"-28 x 5/8"-deflector to splash shield	6	1L,1H	51
	43264-S8 Screw and washer (hex-hd)-5/16"-24 x 7/8"-deflector to radiator case support	6	OL,OH	50
	43264-S8 Screw and washer (hex-hd)-5/16"-24 x 7/8"-deflector to front fender	8	OL,OH,1L,1H	50-51
	43264-S8 Screw and washer (hex-hd)-5/16"-24 x 7/8"-deflector to apron and radiator support	1	1L,1H	51
	43264-S8 Screw and washer (hex-hd)-5/16"-24 x 7/8"-deflector to fender apron	6	OL,OH,1L,1H	50-51
	44719-S8 Washer (flat)-1/4"-deflector to front fender	6	9L,9H,OL,OH,1L,1H	49-51
	44722-S8 Washer (flat)-5/16"	6	9L,9H	49
	44724-S8 Washer (flat)-5/16"-deflector to apron support	6	OL,OH,1L,1H	50-51
	44724-S8 Washer (flat)-5/16"-deflector to front fender apron	6	OL,OH,1L,1H	50-51
8H 8326	Deflector assy (radiator grille air)-upper-RH	1	9L,9H	49
8H 8327	Deflector assy (radiator grille air)-upper-LH	1	9L,9H	49
	34129-S2 Nut (square)-1/4"-20	8	9L,9H	49
	42023-S7 Screw (hex head self tapping)-No. 14-10 x 3/4"	2	9L,9H	49
OL 8344	Sealer (radiator grille air deflector)-2-1/4" x 2-1/4" x 1/4"-Sponge Rubber	2	OL,OH,1L,1H	50-51

# Lincoln and Lincoln Cosmopolitan

## CHASSIS PARTS CATALOGUE

### Radiator Grille-Continued

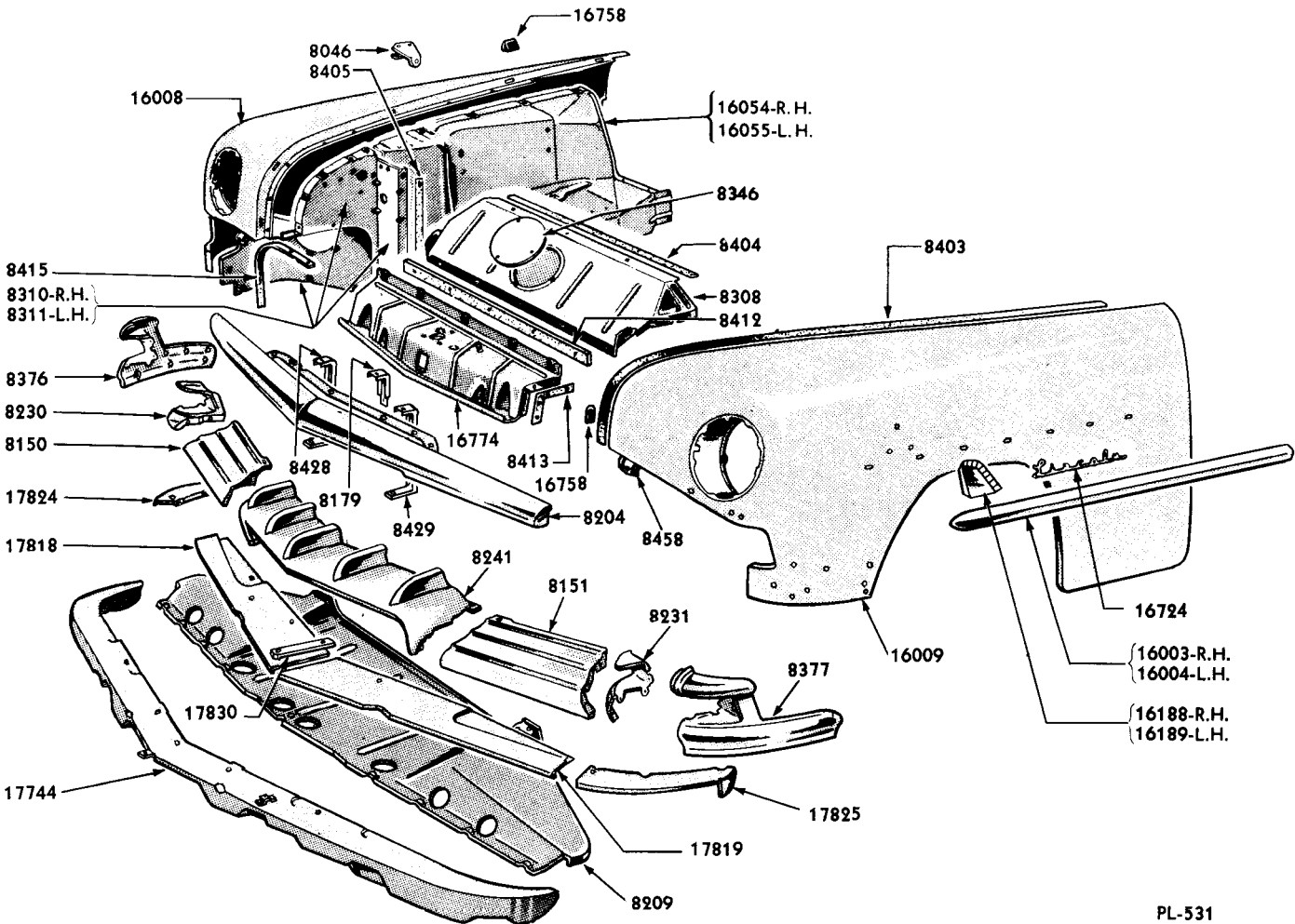

PL-531

### LINCOLN (1951)

Basic numbers only shown on illustration. Order by Part Numbers shown in list of parts.

PART NUMBER	QTY	PART NAME	NO. REQ'D	MODEL	YEAR
7EH 8346		Plate (radiator air deflector cover)-upper	1	9L,9H,OL,OH,LL,1H	49-51
		355888-S32 Nut (spring)-No. 10A-plate to deflector panel	3	1L,1H	51
		32859-S7 Screw (rd-hd self tapping)-No. 10-12 x 1/2"-plate to deflector	3	9L,9H,OL,OH,LL,1H	49-51
7EH 8376		Grille (radiator)-side upper-outer-RH	1	9L,9H	49
OL 8376		Extension (radiator grille upper bar)-RH	1	OL,OH	50
1L 8376		Extension (radiator grille upper bar)-RH	1	1L,1H	51
7EH 8377		Grille (radiator)-side upper-outer-LH	1	9L,9H	49
OL 8377		Extension (radiator grille upper bar)-LH	1	OL,OH	50
1L 8377		Extension (radiator grille upper bar)-LH	1	1L,1H	51

# Lincoln and Lincoln Cosmopolitan

## CHASSIS PARTS CATALOGUE

### Radiator Grille-Continued

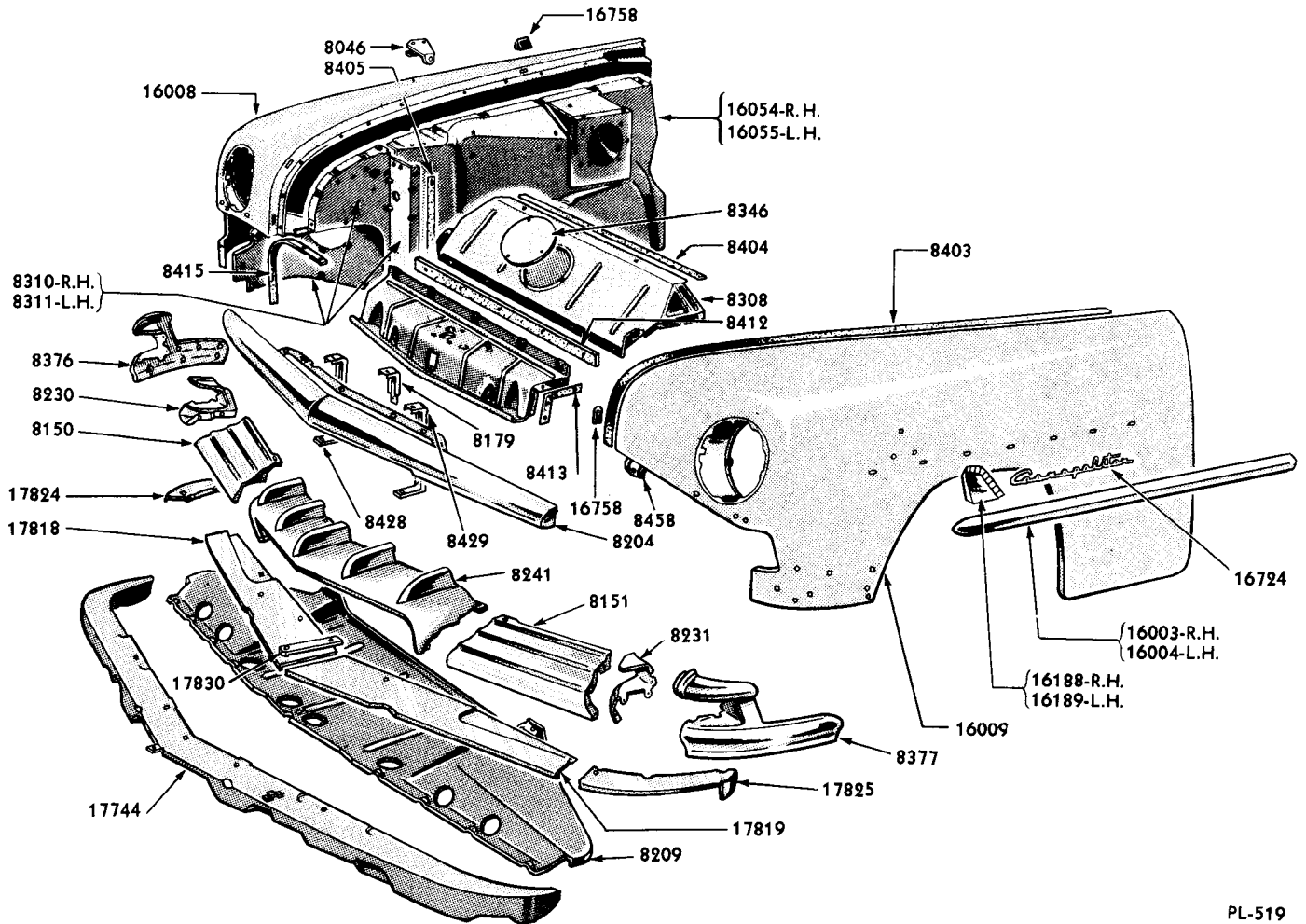

PL-519

### LINCOLN COSMOPOLITAN (1951)

Basic numbers only shown on illustration. Order by Part Numbers shown in list of parts.

PART NUMBER	CLASS	PART NAME	NO. REQ'D	MODEL	YEAR
		350057-37 Screw and washer (hex-hd)-No. 10-24 x 7/16"-extension to lower bar extension	8	OL,OH,LL,LH	50-51
		357225-88 Screw and washer (hex-hd)-1/4"-20 x 1/2"-extension to lower grille bar extension	4	OL,OH	50
		357225-88 Screw and washer (hex-hd)-1/4"-20 x 1/2"-extension to fender	14	OL,OH,LL,LH	50-51
		356381-87 Washer (flat)-3/8"-extension to fender	4	OL,OH,LL,LH	50-51
7EH 8378-B		Grille (radiator side intermediate)-outer-RH	1	9L,9H	49
7EH 8379-B		Grille (radiator side intermediate)-outer-LH	1	9L,9H	49
		20354-S2 Bolt (hex-hd)-1/4"-20 x 13/16"	2	9L,9H	49
		34825-S8 Lockwasher-1/4"	2	9L,9H	49
		33795-S7 Nut (hex)-1/4"-20	2	9L,9H	49
		44719-S8 Washer (flat)-1/4"	2	9L,9H	49

# Lincoln and Lincoln Cosmopolitan

## CHASSIS PARTS CATALOGUE

PART NUMBER	PART NAME	NO. REQ'D	MODEL	YEAR 19
<b>Radiator Grille-Continued</b>				
8H 8402	Anti squeak (radiator support bracket to front fender apron)-2-1/2" long	2	9L,9H,OL,OH,1L,1H	49-51
8H 8403	Anti squeak (front fender to radiator grille air deflector)-24-5/64" long	2	9L,9H,OL,OH	49-50
1L 8403	Anti squeak (front fender to radiator grille air deflector)-14-45/64" long	2	1L,1H	51
8H 8404	Anti squeak (top radiator air deflector)-upper-28-49/64" long	1	9L,9H,OL,OH,1L,1H	49-51
8H 8405	Anti squeak (radiator grille air deflector to radiator support)-18" long	2	9L,9H,OL,OH,1L,1H	49-51
8H 8411	Anti squeak (top radiator air deflector side)-10-21/32" long	2	9L,9H,OL,OH,1L,1H	49-51
8H 8412	Anti squeak (top radiator air deflector lower)-28-11/32" long	1	9L,9H,OL,OH,1L,1H	49-51
8H 8413	Anti squeak (hood catch support to radiator grille air deflector)-7-9/64" long	2	9L,9H,OL,OH,1L,1H	49-51
8H 8415	Anti squeak (front fender apron to radiator grille air deflector)-21-11/16" long	2	9L,9H,OL,OH,1L,1H	49-51
1L 8428	Support (radiator grille)-inner-RH	1	1L,1H	51
1L 8429	Support (radiator grille)-inner-LH	1	1L,1H	51
	20384-S2 Bolt (hex-hd)-1/4"-20 x 1"-support to hood lock support and radiator grille bar	3	1L,1H	51
	23391-S2 Bolt (round head carriage)-1/4"-20 x 7/8"-support to stone deflector	2	1L,1H	51
	34805-S8 Lockwasher-1/4"-support to stone deflector	2	1L,1H	51
	34940-S2 Lockwasher-1/4"-support to hood lock support and radiator grille bar	3	1L,1H	51
	33795-S7 Nut (hex)-1/4"-20-support to stone deflector	2	1L,1H	51
	357225-S8 Screw and washer (hex-hd)-1/4"-20 x 1/2"-support to center grille bar	2	1L,1H	51
	44720-S8 Washer (flat)-1/4"-support to hood lock support and radiator grille bar	4	1L,1H	51
	351601-S8 Washer (cup)-9/32" I.D. x 5/8" O.D. x 1/4"-support to stone deflector	2	1L,1H	51
7EH 8447	Support assy (radiator grille)-inner	2	9L,9H	49
OL 8447	Support assy (radiator grille)-inner	2	OL,OH	50
	33795-S7 Nut (hex)-1/4"-20-inner support to upper grille bar	2	OL,OH	50
	357227-S Nut (retainer)-1/4"-20-support to stone deflector	2	OL,OH	50
	357225-S8 Screw and washer (hex-hd)-1/4"-20 x 1/2"-support to stone deflector	2	OL,OH	50
OL 8454	Support assy (radiator grille)-outer-RH	1	OL,OH	50
OL 8455	Support assy (radiator grille)-outer-LH	1	OL,OH	50

# Lincoln and Lincoln Cosmopolitan

## CHASSIS PARTS CATALOGUE

PART NUMBER	PART NAME	NO. REQ'D	MODEL	YEAR
<b>Radiator Grille—Continued</b>				
	24324-S7 Bolt (hex-hd)-1/4"-20 x 5/8"- lower support to lower grille bar	4	OL,OH	50
	33795-S7 Nut (hex)-1/4"-20-outer support to lower grille bar	4	OL,OH	50
	357225-S8 Screw and washer (hex-hd)-1/4"- 20 x 1/2"-support to air deflector	2	OL,OH	50
OL 8458	Bracket (radiator grille bar to fender)	2	OL,OH,1L,1H	50-51
7EH 8496	Support assy (radiator)-outer	2	9L,9H	49
	24324-S7 Bolt (hex-hd)-1/4"-20 x 5/8"	2	9L,9H	49
	34805-S8 Lockwasher-1/4"	2	9L,9H	49
	33795-S7 Nut (hex)-1/4"-20	2	9L,9H	49
	44719-S8 Washer (flat)-1/4"	2	9L,9H	49

## Water Pump

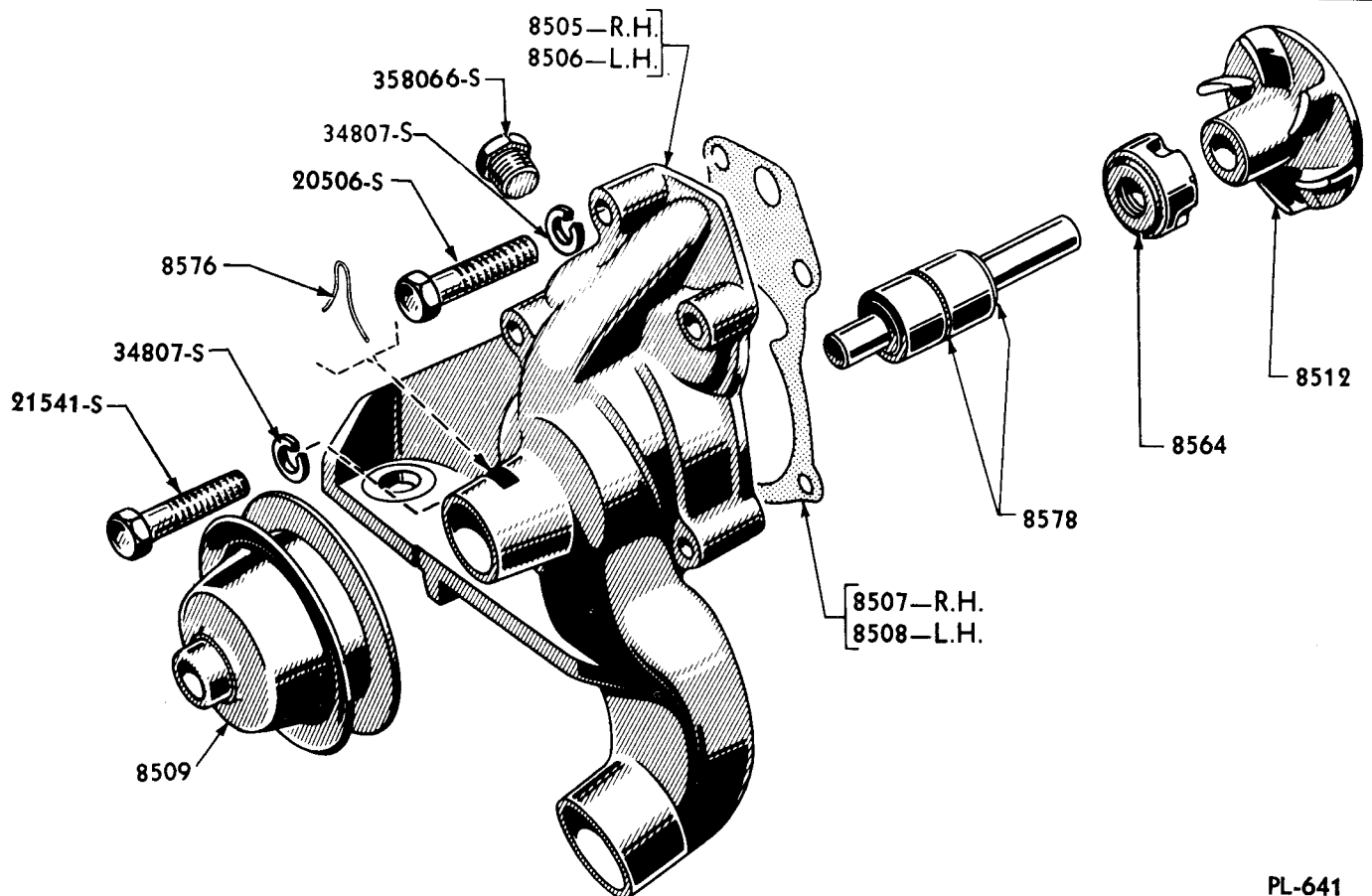

### WATER PUMP (8EL-8501-B)

Basic numbers only shown on illustration. Order by Part Numbers shown in list of parts.

PL-641

# Lincoln and Lincoln Cosmopolitan

## CHASSIS PARTS CATALOGUE

PART NUMBER	CLASS	PART NAME	NO. REQ'D	MODEL	YEAR 19__
<b>Water Pump—Continued</b>					
8EL 8501-B		Pump assy (water)-RH	1	9L,9H	49
8EL 8501-C		Pump assy (water)-RH-bottom flange is 5/8" thick	1	9L,9H	49
8EL 8501-D	NS	Pump assy (water)-RH-bottom flange is 21/32" thick-replaced by one (1) each 8EL-88502 and 8EL-8545-A	1	9L,9H,OL,OH,1L,1H	49-51
8EL 8502-B		Pump assy (water)-LH	1	9L,9H	49
8EL 8502-C		Pump assy (water)-LH-bottom flange is 5/8" thick	1	9L,9H	49
8EL 8502-D	NS	Pump assy (water)-LH-bottom flange is 21/32" thick-replaced by one (1) each 8EL-88503 and 8EL-8552-C	1	9L,9H,OL,OH,1L,1H	49-51
		8EL-88502 Pump assy (water)-less pulley-RH-assemble 21541-S Bolt and 34807-S2 Lockwasher in pump prior to assembly of pulley	1	9L,9H,OL,OH,1L,1H	49-51
		8EL-88503 Pump assy (water)-less pulley-LH-assemble 21541-S Bolt and 34807-S2 Lockwasher in pump prior to assembly of pulley	1	9L,9H,OL,OH,1L,1H	49-51
		8EL-8577-A Belt (fan)-3/4" wide	1	9L,9H	49
		8EL-8577-C Belt (fan and RH water pump)-29/64" wide	1	9L,9H,OL,OH,1L,1H	49-51
		20506-S7 Bolt (hex-hd)-3/8"-16 x 1-3/4"-pump to cylinder block	9	9L,9H,OL,OH,1L,1H	49-51
		21541-S Bolt (hex-hd)-3/8"-16 x 2-5/8"-pump to cylinder block	1	9L,9H,OL,OH,1L,1H	49-51
		356628-S Clip (wiring to water pump mounting bolt)	2	OL,OH	50
		34807-S2 Lockwasher-3/8"	10	9L,9H,OL,OH,1L,1H	49-51
		358066-S8 Plug (counter sunk head)-3/8"	2	9L,9H,OL,OH,1L,1H	49-51

### WATER PUMP CHART

PART NUMBER	CLASS	PART NAME	WATER PUMP							
			8EL-8501-B	8EL-8501-C	8EL-8501-D	8EL-8502-B	8EL-8502-C	8EL-8502-D	8EL-88502	8EL-88503
			NUMBER REQUIRED							
8EL 8505-B		Body (water pump)-RH-bottom flange is 5/8" thick	1	1						
8EL 8505-C		Body (water pump)-RH-bottom flange is 21/32" thick			1				1	
8EL 8506-B		Body (water pump)-LH-bottom flange is 5/8" thick				1	1			
8EL 8506-C		Body (water pump)-LH-bottom flange is 21/32" thick						1	1	
*8EL 8507-B		Gasket (water pump)-RH	1	1	1				1	
*8EL 8508-B		Gasket (water pump)-LH				1	1	1		1
8EL 8509-B		Pulley (water pump)-4" O.D.	1			1				
8EL 8512-B		Impeller (water pump)	1	1	1	1	1	1	1	1
8EL 8545-A		Pulley (water pump)-RH-4-17/64" O.D.		1	1					
7HA 8550		Slinger (water pump shaft)	1	1	1	1	1	1	1	1
8EL 8552-C		Pulley (water pump)-LH-4-17/64" O.D.					1	1		
7RA 8564-B		Seal and sleeve assy (water pump)	1	1	1	1	1	1	1	1
OEL 8570-A		Kit (thermostat and gasket)-157° to 162° opening temperature-consists of the following (2) 8EL-8255-C Gasket (2) 7HT-8575-B Thermostat	Refer to Basic Number 8593							

\* Used with, but not part of Water pump assy

# Lincoln and Lincoln Cosmopolitan

## CHASSIS PARTS CATALOGUE

### Water Pump—Continued

#### WATER PUMP CHART—CONTINUED

PART NUMBER	CLASS	PART NAME	WATER PUMP							
			8EL-8501-B	8EL-8501-C	8EL-8501-D	8EL-8502-B	8EL-8502-C	8EL-8502-D	8EL-88502	8EL-88503
			NUMBER REQUIRED							
7HT 8575-B		Thermostat assy (water)-157° to 162° opening temperature	Refer to Basic Number 8593							
7HT 8575-C		Thermostat assy (water)-177° to 182° opening temperature	Refer to Basic Number 8593							
8EL 8575-B		Thermostat assy (water)-158° to 163° opening temperature	Refer to Basic number 8593							
8HT 8575-A		Thermostat assy (water)-148° to 153° opening temperature	Refer to Basic Number 8593							
1HA 8575-A		Thermostat assy (water)-177° to 182° opening temperature	Refer to Basic Number 8593							
7HA 8576		Retainer (water pump bearing)	1	1	1	1	1	1	1	1
8EL 8577-A		Belt (fan)-3/4" wide	Refer to Basic Number 8502							
8EL 8577-C		Belt (fan and RH water pump)-29/64" wide	Refer to Basic Number 8502							
8EL 8578-B		Bearing and shaft assy (water pump)	1	1	1	1	1	1	1	1
8EL 8591		Kit (water pump repair)-consists of the following (1) 8EL-8507-B Gasket (1) 8EL-8508-B Gasket (1) 8EL-8578-B Bearing (1) 7HA-8576 Retainer (1) 7RA-8564-B Seal (1) 8EL-8512-B Impeller	1	1	1	1	1	1	1	1

PART NUMBER	CLASS	PART NAME	NO. REQ'D	MODEL	YEAR 19__
8EL 8592-A		Connection assy (water outlet)-RH	1	9L,9H,OL,OH,1L,1H	49-51
8EL 8593-A		Connection assy (water outlet)-LH	1	9L,9H,OL,OH,1L,1H	49-51
		8EL-8255-C Gasket (water outlet connection)	2	9L,9H,OL,OH,1L,1H	49-51
		OEL-8570-A Kit (thermostat and gasket)-157° to 162° opening temperature-consists of the following (2) 8EL-8255-C Gasket (2) 7HT-8575-B Thermostat	1	9L,9H,OL,OH,1L,1H	49-51
		1EL-18368-A Kit (thermostat)-177° to 182° opening temperature-consists of the following (2) 8EL-8255-C Gasket (2) 1HA-8575-A Thermostat	1	9L,9H,OL,OH,1L,1H	49-51
		7HT-8575-B Thermostat assy (water)-157° to 162° opening temperature	2	9L,9H,OL,OH,1L,1H	49-51
		7HT-8575-C Thermostat assy (water)-177° to 182° opening temperature	2	9L,9H,OL,OH,1L,1H	49-51
		8EL-8575-B Thermostat assy (water)-158° to 163° opening temperature-use with OEH-8005 and OEL-8005 with permanent Anti-Freeze	2	OL,OH,1L,1H	50-51
		8HT-8575-A Thermostat assy (water)-148° to 153° opening temperature	2	9L,9H,OL,OH,1L,1H	49-51
		1HA-8575-A Thermostat assy (water)-177° to 182° opening temperature	2	9L,9H,OL,OH,1L,1H	49-51
		24388-88 Bolt (hex-hd)-3/8"-16 x 1"-connection to cylinder head	4	9L,9H,OL,OH,1L,1H	49-51
		34807-S2 Lockwasher-3/8"	4	9L,9H,OL,OH,1L,1H	49-51
		72798-S Pin (straight)-1/8" x 7/16"	2	9L,9H,OL,OH,1L,1H	49-51

# Lincoln and Lincoln Cosmopolitan

## CHASSIS PARTS CATALOGUE

### Fan

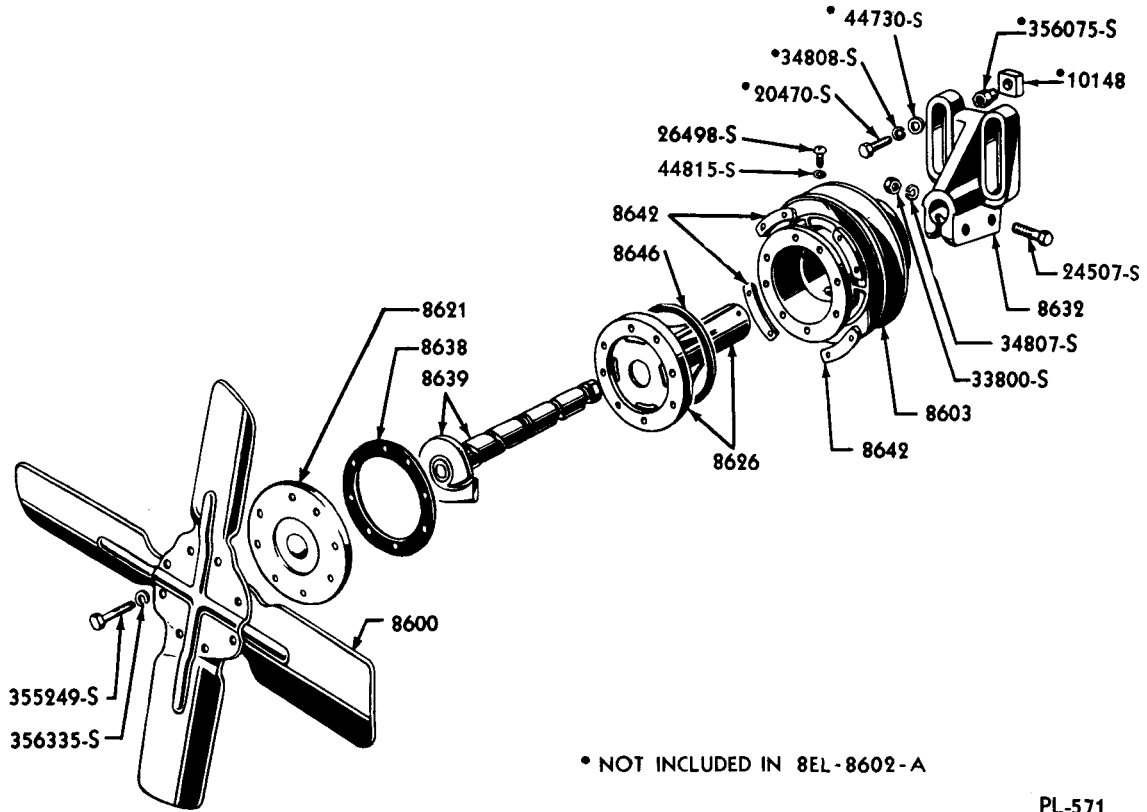

### FAN (OIL TYPE)

PL-571

Basic numbers only shown on illustration. Order by Part Numbers shown in list of parts.

PART NUMBER	CLAS	PART NAME	NO. REQ'D	MODEL	YEAR 19
		8EL-8577-A Belt (fan)-3/4" wide	1	9L,9H	49
		8EL-8577-C Belt (fan and RH water pump)-29/64" wide	1	9L,9H,0L,0H,1L,1H	49-51
8EL 8600-A		Blade assy (fan)-4 blade-18" diameter	1	9L,9H	49
8EL 8600-B		Blade assy (fan)-5 blade-18-1/4" diameter-1-1/4" center bore	1	9L,9H	49
OEL 8600		Blade assy (fan)-5 blade-18-1/4" diameter-1-1/2" center bore	1	0L,0H,1L,1H	50-51
		20326-S7 Bolt (hex-hd)-5/16"-18 x 5/8"	4	9L,9H,0L,0H,1L,1H	49-51
		355249-S Bolt (hex head)-No. 12-32 x 1-1/16"	8	9L,9H	49
		34941-S7 Lockwasher (external tooth)-5/16"	4	9L,9H,0L,0H,1L,1H	49-51
		356335-S Lockwasher-7/32"	8	9L,9H	49
8EL 8602-A	NS	Blade, bracket and pulley assy-oil type-4 blade fan-18" diameter-service details	1	9L,9H	49
8EL 8602-B		Blade, bracket and pulley assy-two piece design-5 blade fan-18-1/4" diameter-1-1/4" center bore	1	9L,9H	49
OEL 8602		Blade, bracket and pulley assy-two piece design-5 blade fan-18-1/4" diameter-1-1/2" center bore	1	0L,0H,1L,1H	50-51



# Lincoln and Lincoln Cosmopolitan

## CHASSIS PARTS CATALOGUE

PART NUMBER	PART NAME	NO. REQ'D	MODEL	YEAR
<b>Fan—Continued</b>				
	20470-S2 Bolt (hex-hd)-7/16"-14 x 1-1/2" -bracket to block	2	9L,9H,OL,OH,LL,1H	49-51
	34808-S2 Lockwasher-7/16"	2	9L,9H,OL,OH,LL,1H	49-51
	44730-S8 Washer (flat)-7/16"	2	9L,9H,OL,OH,LL,1H	49-51
21A 8603	Hub assy (fan)-oil type	1	9L,9H	49
	26498-S7 Screw (rd-hd)-No. 12-24 x 5/8"	1	9L,9H	49
	44815-S Washer (flat)-No. 12	1	9L,9H	49
8EL 8604	Fan and hub assy-oil type-4 blade-18" diameter	1	9L,9H	49
8EL 8620-A	Belt (generator and water pumps)-3/4" wide	1	9L,9H	49
8EL 8620-B	Belt (generator and water pumps)-3/4" wide-used with 60 amp. generator	1	9L,9H	49
8EL 8620-D	Belt (generator and LH water pump)-29/64" wide	1	9L,9H,OL,OH,LL,1H	49-51
8EL 8620-F	Belt (generator and LH water pump)-29/64" wide-used with 60 amp. generator	1	OL,OH,LL,1H	50-51
21A 8621	Spacer (fan blade)-3-23/32" O.D. diameter-oil type	1	9L,9H	49
OEL 8625	Pulley and bracket assy (fan)-used with OEL-8600 blade	1	OL,OH,LL,1H	50-51
21A 8626	Bearing (fan spindle)-oil type	1	9L,9H	49
7EH 8632	Bracket (fan mounting)	1	9L,9H	49
	20470-S8 Bolt (hex-hd)-7/16"-14 x 1-1/2" -bracket to block	2	9L,9H	49
	24507-S7 Bolt (hex-hd)-3/8"-24 x 1-3/4"	2	9L,9H	49
	34807-S2 Lockwasher-3/8"	2	9L,9H	49
	34808-S8 Lockwasher-7/16"	2	9L,9H	49
	33800-S8 Nut (hex)-3/8"-24	2	9L,9H	49
	44730-S8 Washer (flat)-7/16"	2	9L,9H	49
21A 8638	Gasket (fan)	1	9L,9H	49
21A 8639	Spindle & impeller assy (fan hub)	1	9L,9H	49
21A 8642	Nut (double)-fan hub and spindle	4	9L,9H	49
21A 8646	Gasket (fan)-rear-2-7/8" O.D. diameter	1	9L,9H	49

## Air Ventilator

7EH 8702	Conductor assy (ventilating air)-front	2	9L,9H	49
	8H-7301918 Baffles (fresh air vent)	2	9L,9H	49
	355888-S32 Nut (spring)-No. 14	8	9L,9H	49
	42014-S8 Screw (hex head)-No. 10 x 5/8"	8	9L,9H	49
7EH 8716	Screen (ventilating air conductor)-front	2	9L,9H	49
	8H-7301900 Screen (vent air duct inlet)-front	2	OL,OH,LL,1H	50-51

# Lincoln and Lincoln Cosmopolitan

## CHASSIS PARTS CATALOGUE

PART NUMBER	QTY	PART NAME	NO. REQ'D	MODEL	YEAR
					19__
<b>Air Ventilator—Continued</b>					
8L 8719		Bracket (ventilating duct support)	1	9L, 9H	49
		34803-S7 Lockwasher-No. 10	1	9L, 9H	49
		34826-S7 Lockwasher-5/16"	1	9L, 9H	49
		33797-S7 Nut (hex)-5/16"-18	1	9L, 9H	49
		34079-S7 Nut (hex)-No. 10-32	1	9L, 9H	49
		25218-S8 Screw (flat head)-No. 10-32 x 3/8"	1	9L, 9H	49
		36103-S7 Screw (flat head pointed)-5/16" -18 x 1-1/2"	1	9L, 9H	49
		44713-S8 Washer (flat)-No. 10	1	9L, 9H	49
8L 8721-C	NS	Duct (ventilating fresh air)-33" long-passenger side -2 coils per inch-make from 8L-8721-D	1	9L	49
8L 8721-D		Duct (ventilating fresh air)-37" long-driver's side-2 coils per inch	1	9L, 9H	49
8H 8721-C	NS	Duct (ventilating air)-4" I.D.-17-1/2" long-front to valve-2 coils per inch-make from 8H-8721-D	1	9H	49
8H 8721-D		Duct (ventilating air)-4" I.D.-19-1/2" long-valve to dash-2 coils per inch	1	9H	49
8M 8721		Seal (ventilating fresh air duct joint)-Rubber-3-31/32" I.D.-4-3/32"-1-7/64" wide	1	9L	49
8L 8724		Bracket (air duct support)-driver's side	1	9L, 9H	49
		32853-S7 Screw (rd-hd self tapping)-No. 12-11 x 3/8"-bracket to fender apron	1	9L, 9H	49
8H 8725		Clamp assy (air duct retainer)-square-4-1/8" I.D.	2	9H, 0H, 1H	49-51
OM 8725		Clamp assy (fresh air duct)-round 4-3/16" I.D.	4	9L, 9H, 0L, 0H, 1L, 1H	49-51
1M 8725-A		Clamp assy (fresh air duct)-round-4-3/16" I.D.	4	9L, 9H, 0L, 0H, 1L, 1H	49-51
		OH-14566-B Support (fresh air control cable)	1	OH	50
		OL-18561-A Control assy (fresh air regulator) -with one piece lever	1	OL, OH	50
		OM 18561-B Control assy (fresh air reg.)-LH-with riveted lever	1	OL, OH, 1L, 1H	50-51
		OM-18646 Control assy (air reg.)-LH	1	OL, OH, 1L, 1H	50-51
		41036-S8 Screw (hex-hd)-No. 10-32 x 3/8"-control to housing	4	OL, OH, 1L, 1H	50-51
		8M-18570-A Gasket (fresh air valve to dash)-4" I.D.-1/16" thick	2	9L, 9H, 0L, 1L	49-51
		OL-18590 Clip (fresh air regulator control)	1	OL, OH	50
		OM-18590 Clip (fresh air control cable)	1	OL, 1L	50-51
		24308-S7 Bolt (hex head)-1/4"-20 x 1/2"-clip to instrument panel	1	OL, 1L	50-51
		34805-S8 Lockwasher-1/4"-clip to instrument panel	1	OL, OH, 1L, 1H	50-51
		34907-S7 Lockwasher-3/8"	2	9L, 9H	49
		33920-S Nut (hex)-1/4"-20	1	OL, OH	50
		355993-S8 Nut (hex)-3/8"-24	2	9L, 9H	49

# Lincoln and Lincoln Cosmopolitan

## CHASSIS PARTS CATALOGUE

### Air Ventilator—Continued

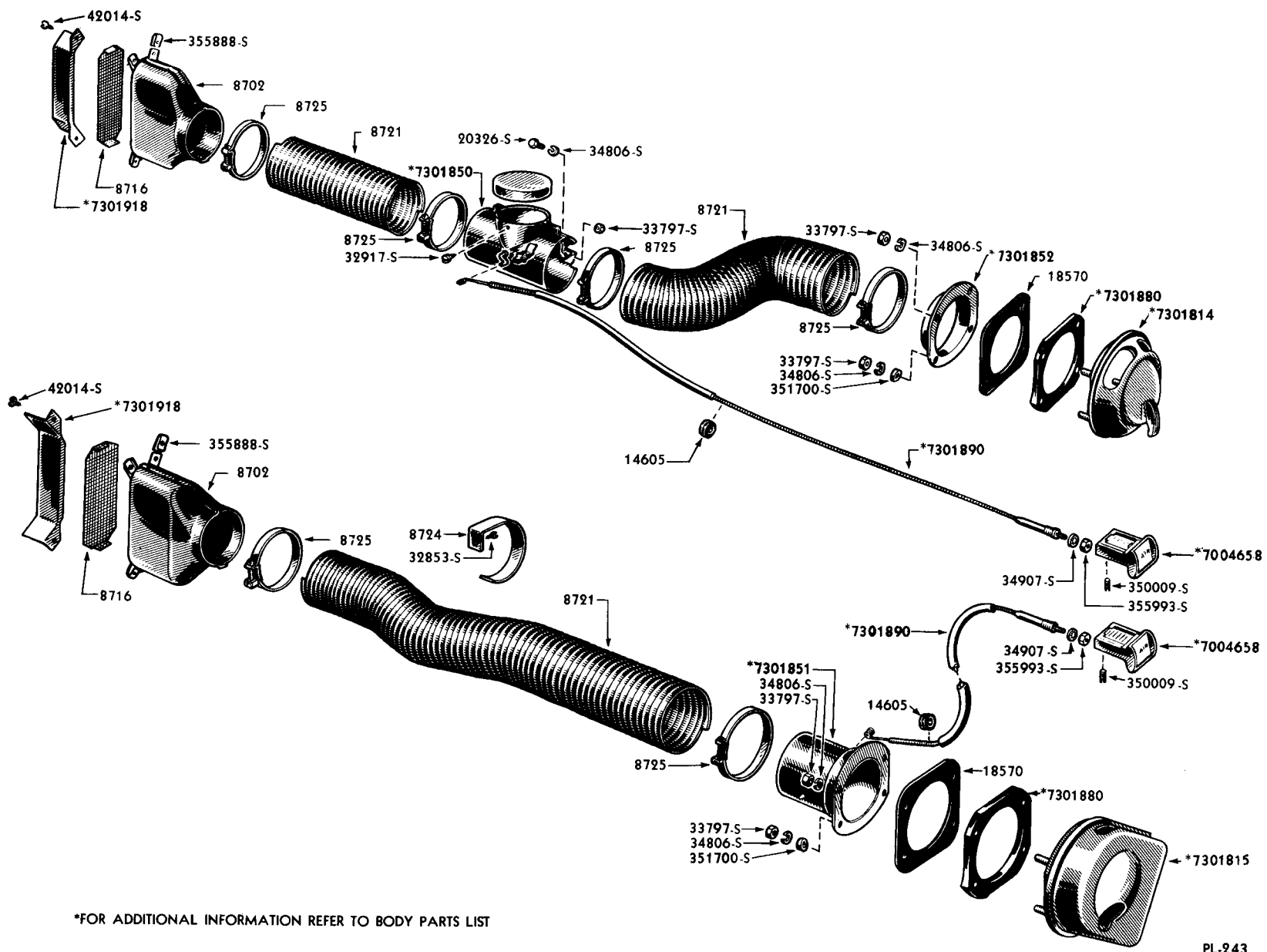

\*FOR ADDITIONAL INFORMATION REFER TO BODY PARTS LIST

PL-243

**LINCOLN COSMOPOLITAN AIR VENTILATOR (9H)**  
Basic numbers only shown on illustration. Order by Part Numbers shown in list of parts.

Air Ventilator—Continued

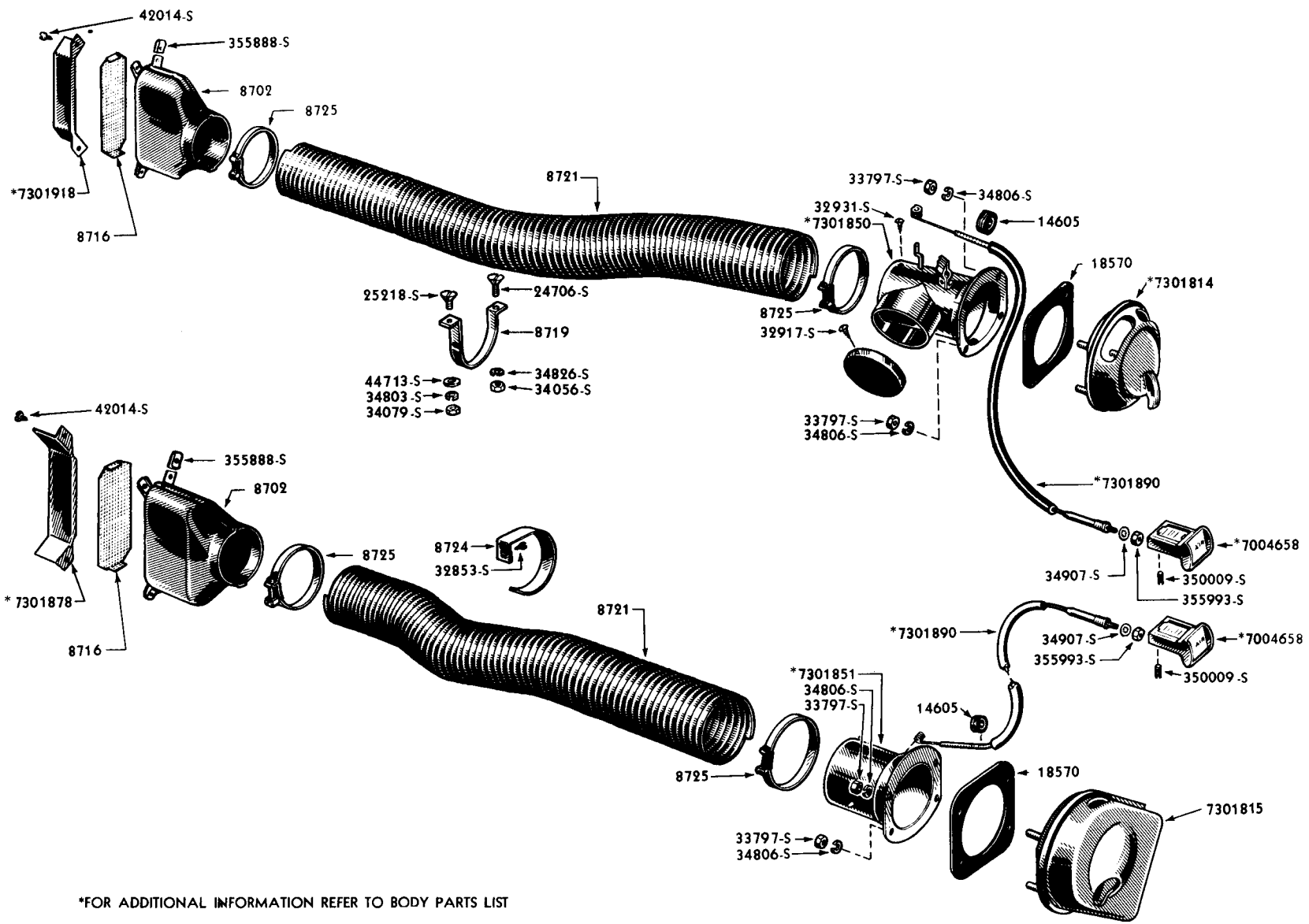

\*FOR ADDITIONAL INFORMATION REFER TO BODY PARTS LIST

PL-556

**LINCOLN AIR VENTILATOR (9L)**

Basic numbers only shown on illustration. Order by Part Numbers shown in list of parts.

# Lincoln and Lincoln Cosmopolitan

## CHASSIS PARTS CATALOGUE

PART NUMBER	PART NAME	NO. REQ'D	MODEL	YEAR 19
<b>Air Ventilator—Continued</b>				
8L-7301814	Register assy (fresh air duct)-RH	1	9L,9H,0L,1L	49-51
8M-7301815-B	Register assy (fresh air duct)-LH	1	9L,9H	49
8H-7301850	Valve assy (fresh air duct)-RH	1	9H	49
8M-7301850	Valve assy (fresh air duct)-RH	1	9L	49
OM-7201850-A	Valve assy (fresh air duct)-RH-when heater is used	1	0L,1L	50-51
8H-7301851	Valve assy (fresh air duct)-LH	1	9H	49
8L-7301851	Valve assy (fresh air duct)-LH	1	9L	49
OM-7201851-A	Valve assy (fresh air duct)-RH-when heater is not used	1	0L,1L	50-51
8H-7301852	Collar (fresh air duct)-Steel	1	9H	49
OL-7201878	Connector (body vent air duct)-RH or LH	1 or 2	0L,0H,1L,1H	50-51
8M-7001879	Connector (body vent air duct)-RH	2	0L,1L	50-51
8H-7301880	Gasket (fresh air register to dash) -4-5/16" I.D.-Rubber	2	9H	49
8L-7001890	Cable assy (fresh air vent control) -30" long-without anti rattle-without stops	2	9L	49
8L-7301890-B	Cable assy (fresh air vent control) -30" long-with anti rattle-without stops	2	9L	49
8L-7301890-C	Cable assy (fresh air vent control) -30" long-with anti rattle-with stops	2	9L	49
8H-7301890-B	Cable assy (fresh air vent control) -34" long-without anti rattle-without stops	2	9H	49
8H-7301890-C	Cable assy (fresh air vent control) -34" long-with anti rattle-with stops	2	9H	49
OM-7201890-B	Cable assy (fresh air inlet)-RH	1	0L	50
OM-7201890-C	Cable assy (fresh air inlet)-RH	1	1L	51
OL-7201891-B	Cable assy (fresh air inlet)-LH	1	0L	50
OL-7201891-C	Cable assy (fresh air inlet)-LH	1	1L	51
OH-7301890-C	Cable assy (fresh air inlet)-RH	1	0H	50
OH-7301890-D	Cable assy (fresh air inlet)-RH	1	1H	51
OH-7301891-B	Cable assy (fresh air inlet)-LH	1	0H	50
OH-7301891-C	Cable assy (fresh air inlet)-LH	1	1H	51
8M-14599	Clip (attach RH air control to glove compartment)	1	0L,1L	50-51
09A-14605	Grommet (air control through dash)-Rubber	2	9L,9H,0L,0H,1L,1H	49-51
16H-16899-A	Clip (vent air control to bracket)	2	0H	50

# Lincoln and Lincoln Cosmopolitan

## CHASSIS PARTS CATALOGUE

PART NUMBER	PART NAME	NO. REQ'D	MODEL	YEAR 19__
<b>Air Ventilator—Continued</b>				
OL-7201902	Ventilating air duct assy-complete-RH	1	OL,1L	50-51
OL-7201903	Ventilating air duct assy-complete-LH	1	OL,1L	50-51
OH-7301902	Ventilating air duct assy-complete-RH	1	OH,1H	50-51
OH-7301903	Ventilating air duct assy-complete-LH	1	OH,1H	50-51
8H-7301934	Duct assy (fresh air vent)-outlet-RH	1	OH,1H	50-51
8H-7301935	Duct assy (fresh air vent)-outlet-LH	1	OH,1H	50-51
OL-7201935	Duct assy (fresh air vent)-outlet-LH	1	OL,1L	50-51
OL-7201937	Collar (vent air duct to splash panel)-upper	1	OL,1L	50-51
OL-7201941-B	Collar (vent air duct to fender apron)	1	OL,1L	50-51
OL-7201943	Collar (vent air duct to splash panel)-lower	1	OL,1L	50-51
OL-7201939	Screen assy (fresh air vent outlet)-LH	1	OL,1L	50-51
OH-7301939	Screen assy (fresh air vent outlet)-RH and LH	2	OH,1H	50-51
8H-7301959	Seal (vent air duct to heater outlet)-Rubber	1	OH,1H	50-51
OL-7201966	Spacer (vent air duct to cowl)-Rubber	1	OL,1L	50-51
8H-7301966	Spacer (vent air duct to cowl)-Rubber	2	OH,1H	50-51
OL-7201969	Seal (vent air duct to splash panel)	1	OL,1L	50-51
8H-7301972	Cover (air valve damper shaft)-upper	2	OH,1H	50-51
OL-7201973-B	Seal (vent air duct to fender apron)	1	OL,1L	50-51

*Lincoln and Lincoln Cosmopolitan*

CHASSIS PARTS CATALOGUE

Air Ventilator — Continued

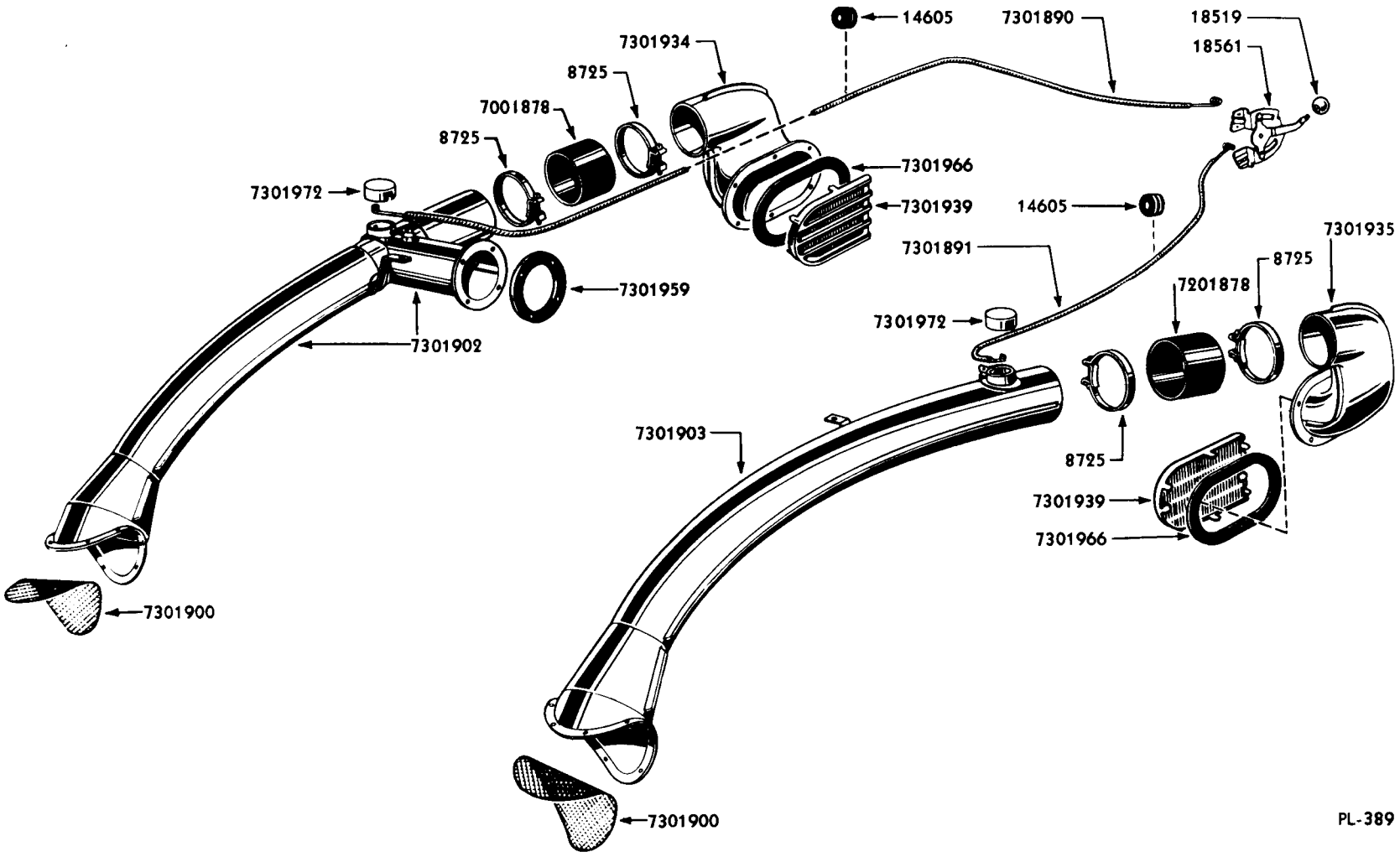

LINCOLN COSMOPOLITAN AIR VENTILATOR (OH)  
Basic numbers only shown on illustration. Order by Part Numbers shown in list of parts.

PL-389

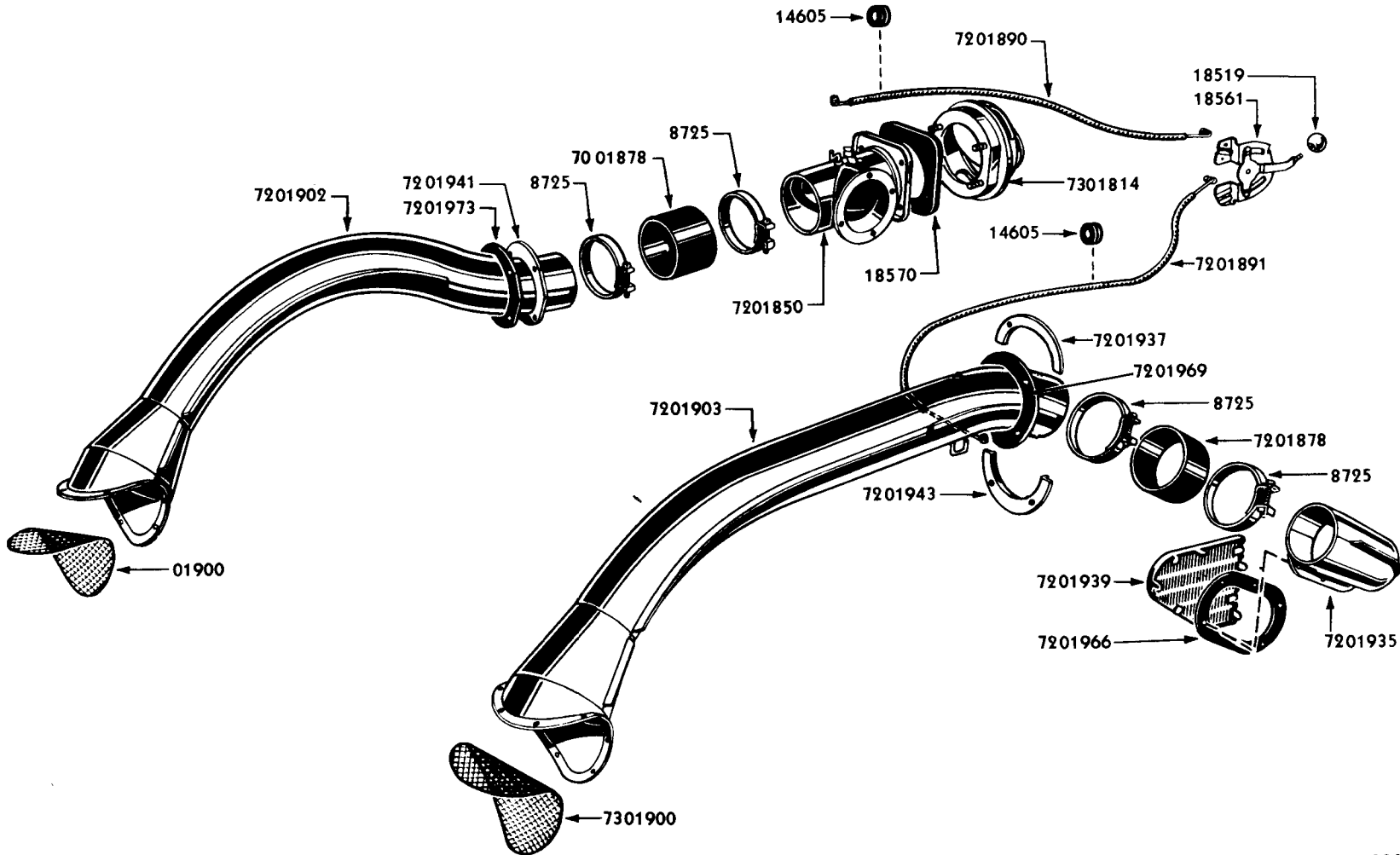

PL-390

**LINCOLN AIR VENTILATOR (OL)**

Basic numbers only shown on illustration. Order by Part Numbers shown in list of parts.



# Lincoln and Lincoln Cosmopolitan

CHASSIS PARTS CATALOGUE

Air Ventilator—Continued

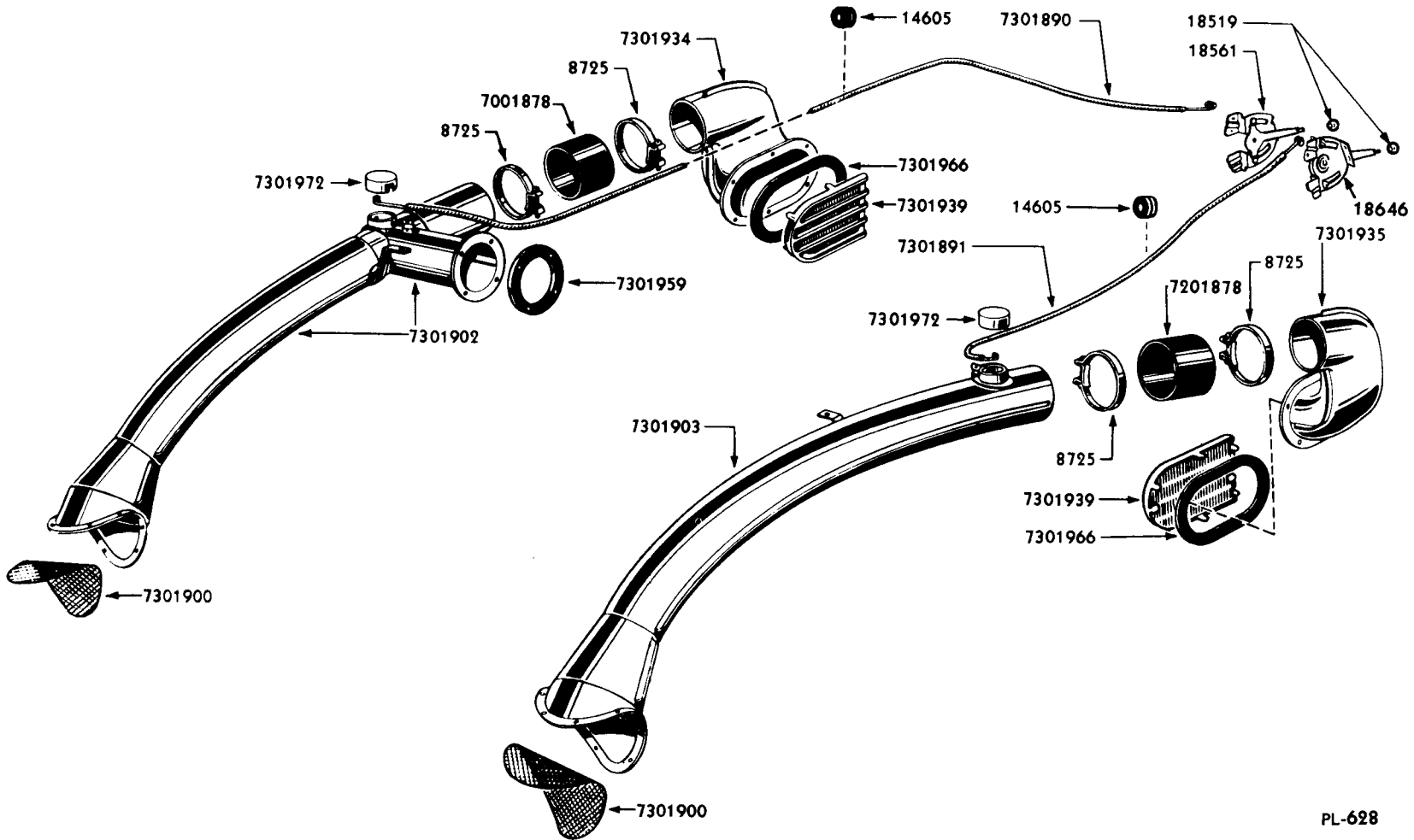

PL-628

## LINCOLN COSMOPOLITAN AIR VENTILATOR (1H)

Basic numbers only shown on illustration. Order by Part Numbers shown in list of parts.

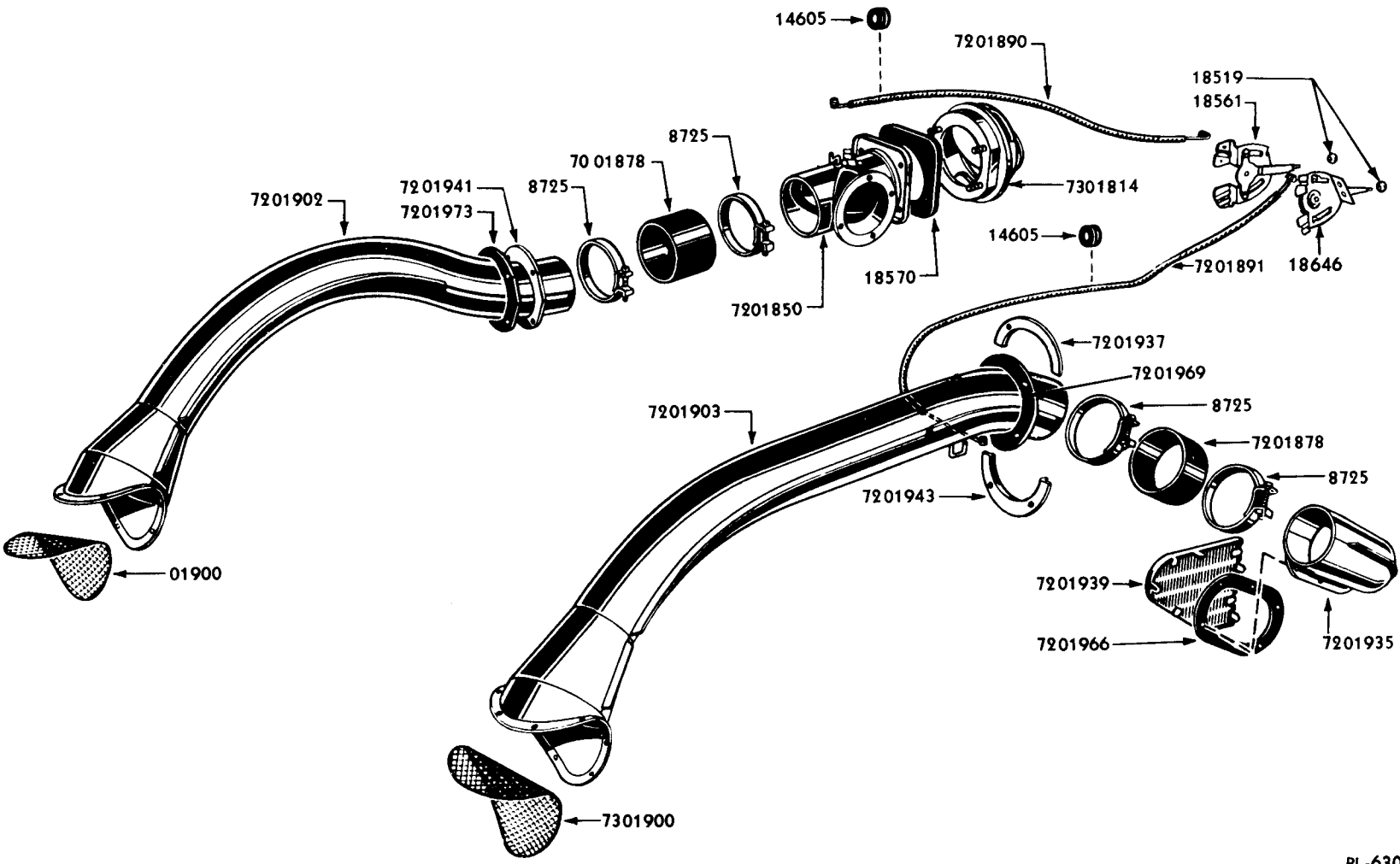

PL-630

**LINCOLN AIR VENTILATOR (1L)**

Basic numbers only shown on illustration. Order by Part Numbers shown in list of parts.

# Lincoln and Lincoln Cosmopolitan

## CHASSIS PARTS CATALOGUE

PART NUMBER	CHASSIS	PART NAME	NO. REQ'D	MODEL	YEAR 19__
<b>Fuel Tank, Fuel Gauge and Oil Gauge</b>					
7EH 9002		Tank assy (fuel)-approximately 34" overall length-has no vent tube	1	9H	49
8H 9002		Tank assy (fuel)-approximately 34" overall length-has vent tube beside filler hole	1	9H,OH,1H	49-51
*8M 9002-A		Tank assy (fuel)-approximately 35" overall length-with Terene Plate tank top-alternate with 8M-9002-C	1	9L,OL,1L	49-51
*8M 9002-C		Tank assy (fuel)-with Steel tank top-alternate with 8M-9002-A	1	9L,OL,1L	49-51
		24389-S8 Bolt (hex-hd pointed)-3/8"-24 x 1"-fuel tank to rear cross member	2	9L,9H,OL,OH,1L,1H	49-51
		34807-S2 Lockwasher-3/8"-fuel tank to rear cross member	2	9L,9H,OL,OH,1L,1H	49-51
		353055-S7 Plug (extended head pipe)-1/4"-fuel tank drain	1	9L,9H,OL,OH,1L,1H	49-51
1M 9008		Cover (fuel tank filler floor opening)-Steel-with 2-21/32" diameter hole for filler pipe	1	1L	51
		32938-S7 Screw (pan-hd self tapping)-No. 10-12 x 5/8"-fuel tank filler floor opening cover to floor pan	4	1L	51
		44713-S8 Washer (flat)-No. 10	4	1L	51
8H 9030		Cap assy (fuel tank)-2-23/64" O.D.-with tangs	1	9H,OH,1H	49-51
8M 9030		Cap assy (fuel tank)-2-7/16" O.D.-with handle on top	1	9L,OL,1L	49-51
1M 9030-A		Cap assy (fuel tank)-2-17/32" O.D.-with tangs	1	1L	51
8M 9032		Pipe and hose assy (fuel tank filler)-used with 8M-9002-A Fuel Tank assy	1	9L,OL,1L	49-51
8H 9032		Pipe and hose assy (fuel tank filler)-used with 7EH-9002 Fuel Tank assy	1	9H	49
7EH 9034	NS	Filler assy (fuel tank)-replaced by 8H-9032 Pipe and Hose assy	1	9H	49
8M 9034-A		Filler assy (fuel tank)-used with 8M-9002-A Fuel Tank assy	1	9L,OL	49-50
8H 9034-A		Filler assy (fuel tank)-used with 8H-9002 Fuel Tank assy	1	9H,OH	49-50
1H 9034		Pipe filler assy (fuel tank)	1	1H	51
1M 9034		Pipe filler assy (fuel tank)	1	1L	51
		20347-S2 Bolt (hex-hd pointed)-5/16"-24 x 3/4"-filler assy to frame	2	9H,OH,1H	49-51
		34806-S2 Lockwasher-5/16"-filler assy to frame	2	9H,OH,1H	49-51
78 9047		Hose (fuel tank filler)-2-3/4" long	1	9H,OH,1H	49-51
21AF 9047-A		Hose (fuel tank filler)-3-3/32" long	1	9L,OL	49-50
1M 9047		Hose (fuel tank filler)-3-21/32" long	1	1L	51
		91A-8287 Clamp assy (fuel tank filler hose)-2-9/32" diameter	2	9H,OH,1H	49-51
		11A-8287 Clamp assy (fuel tank filler hose)-2-39/64" diameter	2	9L,OL,1L	49-51
		34141-S7 Nut (square)-No. 10-32	2	9L,9H,OL,OH,1L,1H	49-51
		27177-S7 Screw (rd-hd)-No. 10-32 x 1-1/2"	2	9L,9H,OL,OH,1L,1H	49-51

\* Alternate material due to Material Emergency

# Lincoln and Lincoln Cosmopolitan

## CHASSIS PARTS CATALOGUE

PART NUMBER	PART NAME	NO. REQ'D	MODEL	YEAR 19__
<b>Fuel Tank, Fuel Gauge and Oil Gauge—Continued</b>				
8M 9066	Hanger assy (fuel tank front)	1	9L,OL,1L	49-51
8H 9066	Hanger assy (fuel tank front)	1	9H,OH,1H	49-51
	24349-S7 Bolt (hex-hd)-3/8"-24 x 3/4"- hanger assy to frame-replaces 20349-S7	1	9L,9H,OL,OH,1L,1H	49-51
	350508-S7 Bolt (hex-hd drilled)-3/8"-24 x 3/4"-hanger to fuel tank- front	1	9L,9H,OL,OH,1L,1H	49-51
	34807-S2 Lockwasher-3/8"-hanger assy to rear cross member	1	9L,9H,OL,OH,1L,1H	49-51
7A 9072-A	Grommet (fuel tank filler neck)-2-3/16" I.D. x 3-21/64" O.D. x 3/8" thick-Rubber	1	9L,OL	49-50
1M 9072	Seal (fuel tank filler to floor pan)-Sponge Rubber- 4-1/2" diameter hole x 3/16" thick	1	1L	51
7A 9080-A	Grommet (fuel tank filler)-3-1/2" I.D. x 4-11/32" O.D.-Rubber	1	9L,OL	49-50
0A 9080	Grommet (fuel tank filler)	2	1L	51
59A 9167	Nut (fuel pump gas strainer thumb)	1	9L,9H,OL,OH,1L,1H	49-51
8H 9170	Hose (fuel tank vent pipe)-2-1/4" long-used with 8H-9002 Fuel Tank assy	1	9H,OH,1H	49-51
8M 9170-A	Hose (fuel tank filler air relief)-3" long	1	9L,9H,OL,1L	49-51
8M 9170-B	Hose (fuel tank filler air relief)-3" long	1	9L,9H,OL,1L	49-51
8M 9171-A	Clamp assy (fuel tank vent pipe hose)	1	9L,9H,OL	49-50
8M 9171-B	Clamp (fuel tank vent pipe hose)-self compressing spring wire type	1	9L,9H,OL,1L	49-51
8H 9171-A	MS Clamp assy (fuel tank vent pipe hose)-7/16" wide- replaced by 8H-9171-B	2	9H,OH	49-50
8H 9171-B	Clamp assy (fuel tank vent pipe hose)-1/2" wide	2	9H,OH,1H	49-51
8CM 9224-B	Adapter (carburetor fuel inlet)-27/32" overall length	1	OL,OH,1L,1H	50-51
8CM 9229	Gasket (carburetor fuel inlet adapter)-Hard Fibre- 19/32" I.D. x 45/64" O.D. x 1/32" thick	1	OL,OH,1L,1H	50-51
B 9242-A	Ferrule (fuel line)-1/4" tubing	1	9L,9H	49
96H 9242	Ferrule (fuel line)-5/16" tubing	1	9L,9H,OL,OH,1L,1H	49-51
8L 9271	Cluster assy (instrument)-less instruments	1	9L,9H	49
8L 9272-A	Bar (instrument cluster bus)-overall length-3-1/32"	1	9L,9H	49
8L 9272-B	Bar (instrument cluster bus)-overall length-2-1/64"	1	9L,9H	49
21A 9272	Bar (instrument cluster bus)-overall length 1-17/32"	1	OL,OH,1L,1H	50-51
	350849-S7 Nut (hex)-No. 10-32	1	9L,9H,OL,OH,1L,1H	49-51
8L 9273	Indicator assy (oil pressure)-instrument group	1	9L,9H	49
OL 9273	Indicator assy (oil pressure)-instrument group	1	OL,OH,1L,1H	50-51
	34803-S7 Lockwasher-No. 10-wiring to indicator assy	2	9L,9H,OL,OH,1L,1H	49-51
	34079-S7 Nut (hex)-No. 10-32-wiring to indicator assy	2	9L,9H,OL,OH,1L,1H	49-51
	37611-S7 Screw (fillister hd)-No. 8-32 x 1/4"-indicator to case	2	9L,9H,OL,OH,1L,1H	49-51

# Lincoln and Lincoln Cosmopolitan

## CHASSIS PARTS CATALOGUE

PART NUMBER	PART NAME	NO. REQ'D	MODEL	YEAR 19__
<b>Fuel Tank, Fuel Gauge and Oil Gauge—Continued</b>				
21C 9275-A	Gauge assy (fuel)-tank unit	1	9H, 9H, 1H	49-51
99A 9275-B	Gauge assy (fuel)-tank unit	1	9L, 9L, 1L	49-51
	34802-S7 Lockwasher-No. 8-wiring to fuel level sender	1	9L, 9H, 9L, 9H, 1L, 1H	49-51
	26457-S7 Screw (rd-hd)-No. 8-32 x 1/4"-wiring to fuel level sender	1	9L, 9H, 9L, 9H, 1L, 1H	49-51
	42672-S8 Screw and lockwasher assy (fillister hd)-No. 10-32 x 3/8"-fuel tank gauge unit to fuel tank	6	9L, 9H, 9L, 9H, 1L, 1H	49-51
68 9276	Gasket (fuel tank gauge unit flange)	1	9L, 9H, 9L, 9H	49-51
41A 9278	Gauge (oil pressure)-engine unit	1	9L, 9H, 9L, 9H, 1L, 1H	49-51
	26457-S7 Screw (rd-hd)-No. 8-32 x 1/4"-wiring to oil pressure sender	1	9L, 9H, 9L, 9H, 1L, 1H	49-51
	34802-S7 Lockwasher-No. 8-wiring to oil pressure sender	1	9L, 9H, 9L, 9H, 1L, 1H	49-51
8L 9280	Indicator assy (fuel level)-instrument cluster	1	9L, 9H	49
OL 9280	Indicator assy (fuel level)-instrument group	1	9L, 9H, 9L, 9H	50-51
	34803-S7 Lockwasher-No. 10-wiring to indicator assy	2	9L, 9H, 9L, 9H, 1L, 1H	49-51
	34079-S7 Nut (hex)-No. 10-32-wiring to indicator assy	2	9L, 9H, 9L, 9H, 1L, 1H	49-51
	37611-S7 Screw (fillister hd)-No. 8-32 1/4"-indicator to case	2	9L, 9H, 9L, 9H, 1L, 1H	49-51
8H 9282	Line assy (fuel)-117-3/4" overall length	1	9H, 9H, 1H	49-51
	34390-S7 Nut (hex)-1/4"-20-fuel line to dash panel	1	9H, 9H, 1H	49-51
8M 9282-A	Line assy (fuel)-109-1/2" overall length	1	9L, 9L, 1L	49-51
	358360-S Clip (fuel line to dash panel)	1	9H, 9H, 1H	49-51
	7RA-14197-A Clip (fuel line to frame)	5	9L, 9H, 9L, 9H, 1L, 1H	49-51
	31527-S7 Screw (hex washer head self tapping)-No. 14-10 x 1/2"-fuel line to dash panel	1	9L, 9L, 1L	49-51
8EL 9283	Pipe assy (flexible conn. line to fuel pump inlet)	1	9L, 9H, 9L, 9H, 1L, 1H	49-51
	353245-S Elbow (inverted)-1/2"-20-adapter for fuel pump inlet line	1	9L, 9H, 9L, 9H, 1L, 1H	49-51
	353367-S Clip (tube)-49/64" wide x 2-21/32" long for 5/16" diameter pipe	1	9L, 9H, 9L, 9H, 1L, 1H	49-51
8L 9288	Hose assy (fuel pump to fuel line)	1	9L, 9H, 9L, 9H, 1L, 1H	49-51
8A 9296	NS Clip-fuel line to dash-repair locally	1	9L, 9L, 1L	49-51
8M 9299	Anti squeak (fuel tank to hanger)	3	9L, 9H, 9L, 9H, 1L, 1H	49-51

# Lincoln and Lincoln Cosmopolitan

## CHASSIS PARTS CATALOGUE

PART NUMBER	PART NAME	NO. REQ'D	MODEL	YEAR 19__
<b>Fuel Pump</b>				
8EL 9349	Kit (fuel pump repair)-consists of the following (4) 1BA-9352-A Valve (1) 40-9357 Washer (1) 11A-9361 Plate (1) 49B-9364 Gasket (1) 8EL-9365 Screen (2) 49B-9367 Gasket (1) 11A-9367 Gasket (1) 7RA-9378 Pin (1) 7RA-9380 Spring (1) 8EL-9381 Link (1) 7RA-9382 Spacer (1) 7RA-9389 Bushing (1) 8EL-9396 Spring (1) 8EL-9398-A Diaphragm (1) 49B-9408 Gasket (1) 7RA-9417 Gasket (1) 49B-9418 Washer (2) 1BA-9468-A Retainer (1) 49B-9469 Oil seal (1) 1BA-9469-A Oil seal (1) 7RA-99361 Plate (1) 7RA-99367 Gasket (1) 8EL-99380 Link (1) 8EL-99381 Link (1) 8EL-99390 Diaphragm (1) 8EL-99396 Spring (2) 26466-S6 Screw (1) 27068-S7 Screw (4) 31628-S7 Screw (4) 34803-S7 Lockwasher (2) 352896-S Washer	1	9L,9H,OL,OH,LL,1H	49-51
HBK 9349-A	Kit (fuel and vacuum pump repair)-used with LEL-9350-A-consists of the following (6) 1BA-9352-A Valve (1) 49B-9364 Gasket (2) 49B-9367-A Gasket (1) 7RA-9378 Pin (1) 1BA-9380-B Spring (1) 49B-9381 Link (1) 7RA-9382 Spacer (1) 7RA-9389 Bushing (1) 8EL-9396 Spring (1) 49B-9397 Gasket (1) LEL-9398-A Diaphragm (1) 8EL-9417 Gasket (1) 49B-9418 Washer (2) 1BA-9468-A Retainer (2) 1BA-9469-A Oil seal (3) 1BA-99367-A Gasket (1) LEL-99380-A Link (1) LEL-99381-A Link (1) LEL-99390-A Diaphragm (1) 8EL-99396 Spring (2) 352896-S Washer	1	1L,1H	51
8EL-99360	Kit (fuel pump strainer)-consists of the following (1) 8EL-9365 Strainer (1) 49B-9364 Gasket	1	9L,9H,OL,OH,LL,1H	49-51
8EL 9350-A	Pump assy (fuel)	1	9L,9H,OL,OH,LL,1H	49-51
LEL 9350-A	Pump assy (fuel)	1	1L,1H	51
	87381-S Elbow-1/8"-pipe male thread and 7/16"-24 female thread- vacuum booster to W/S wiper tube	1	9L,9H,OL,OH,LL,1H	49-51
	06H-17543-C Tube (vacuum pump to intake mani- fold)-25' roll	as reqd	1L,1H	51
	357518-S Connector-1/2"-14 x 1/2"-27- elbow to intake manifold	1	1L,1H	51
	358003-S Elbow-1/8"-27-tube to intake manifold	1	1L,1H	51

# Lincoln and Lincoln Cosmopolitan

## CHASSIS PARTS CATALOGUE

### Fuel Pump—Continued

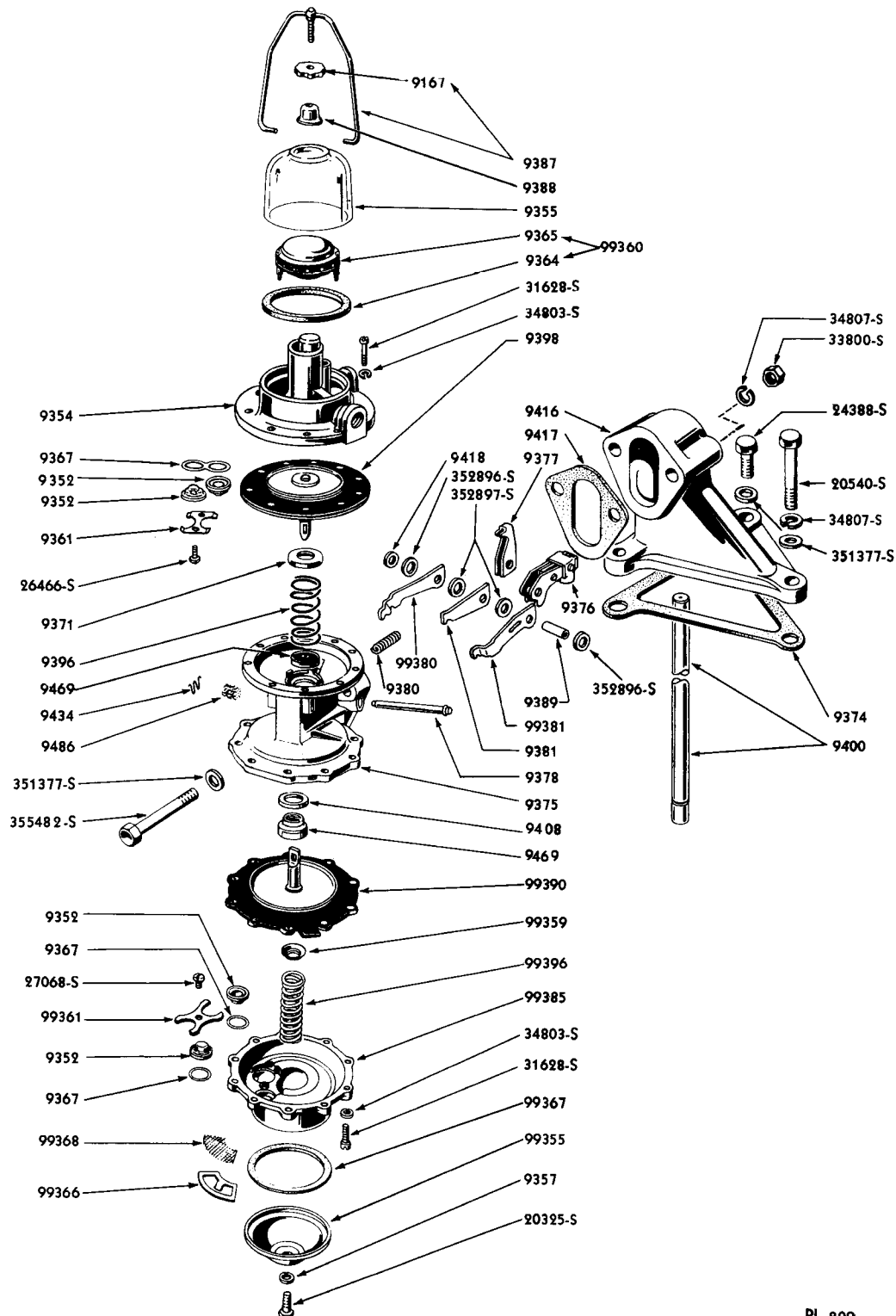

PL-809

### FUEL PUMP (8EL-9350-A) AND RELATED PARTS

Basic numbers only shown on illustration. Order by Part Numbers shown in list of parts.

# Lincoln and Lincoln Cosmopolitan

## CHASSIS PARTS CATALOGUE

PART NUMBER	PART NAME	NO. REQ'D	MODEL	YEAR
<b>Fuel Pump-Continued</b>				
8EL-17536	Pipe assy (vacuum booster to windshield wiper hose)	1	9L,9H,OL,OH,1L,1H	49-51
355482-S	Bolt (hex-hd)-3/8"-24 x 3" -pump to adapter	2	9L,9H,OL,OH,1L,1H	49-51
353002-S	Connector (inverted male)-9/16" -carb. line to fuel pump	2	9L,9H,OL,OH,1L,1H	49-51
34807-S2	Lockwasher-3/8"-fuel pump to adapter	2	9L,9H,OL,OH,1L,1H	49-51
33800-S8	Nut (hex)-3/8"-24-fuel pump to adapter	2	9L,9H,OL,OH,1L,1H	49-51
351377-S7	Washer (flat)-3/8"-fuel pump to adapter	2	9L,9H,OL,OH,1L,1H	49-51
351489-S2	Washer (special)-flanged-13/32" -fuel pump to adapter	2	9L,9H,OL,OH,1L,1H	49-51
11A 9352	Valve assy (fuel pump)	2	9L,9H,OL,OH,1L,1H	49-51
11A 9352	Valve assy (vacuum pump)	2	9L,9H,OL,OH,1L,1H	49-51
1BA 9352-A	Valve assy (fuel pump)	2	9L,9H,OL,OH,1L,1H	49-51
1BA 9352-A	Valve assy (vacuum pump)	2or4	9L,9H,OL,OH,1L,1H	49-51
49B 9354	Body assy (fuel pump upper)	1	9L,9H,OL,OH,1L,1H	49-51
	34803-S7 Lockwasher-No. 10	10	9L,9H,OL,OH,1L,1H	49-51
	31628-S7 Screw (fillister head)-No. 10-32 x 5/8"	10	9L,9H,OL,OH,1L,1H	49-51
49B 9355	Bowl (fuel pump filter)-Glass	1	9L,9H,OL,OH,1L,1H	49-51
40 9357	Washer (fuel pump vacuum pump cover plate screw)	1	9L,9H,OL,OH,1L,1H	49-51
11A 9361	Plate (fuel pump valve)	1	9L,9H,OL,OH,1L,1H	49-51
	26466-S6 Screw (round head)-No. 6-32 x 3/8"	2	9L,9H,OL,OH,1L,1H	49-51
49B 9364	Gasket (fuel pump filter bowl)	1	9L,9H,OL,OH,1L,1H	49-51
8EL 9365	NS Screen assy (fuel pump filter bowl)-serviced in 8EL-9349, 8EL-99360 Kits	1	9L,9H,OL,OH,1L,1H	49-51
11A 9367	Gasket (fuel pump valve to upper body)	1	9L,9H,OL,OH,1L,1H	49-51
49B 9367	Gasket (vacuum pump valve to body)	2	9L,9H,OL,OH,1L,1H	49-51
8EL 9369	Pipe assy (fuel pump to carburetor)-11-5/32" developed length	1	9L,9H,OL,OH,1L,1H	49-51
7RA 9371	Retainer (fuel pump diaphragm spring)	1	9L,9H,OL,OH,1L,1H	49-50
8EL 9374	Gasket (fuel pump adapter to manifold)	1	9L,9H,OL,OH,1L,1H	49-51
8EL 9375	Body & oil seal assy (fuel pump lower)	1	9L,9H,OL,OH,1L,1H	49-51
1EL 9375-A	Body and oil assy (fuel pump lower)-used with 1EL-9350-A	1	1L,1H	51
8EL 9376	Arm assy (fuel and vacuum pump rocker)	1	9L,9H,OL,OH,1L,1H	49-51
8CM 9377	Spacer (fuel and vacuum pump rocker arm link)	1	9L,9H,OL,OH,1L,1H	49-51
7RA 9378	Pin (fuel and vacuum pump rocker arm)	1	9L,9H,OL,OH,1L,1H	49-51
7RA 9380	Spring (fuel and vacuum pump rocker arm return)	1	9L,9H,OL,OH,1L,1H	49-51
1BA 9380-B	Spring (fuel and vacuum pump rocker arm)	1	1L,1H	51



# Lincoln and Lincoln Cosmopolitan

## CHASSIS PARTS CATALOGUE

PART NUMBER	PART NAME	NO. REQ'D	MODEL	YEAR 19__
<b>Fuel Pump—Continued</b>				
8EL 9381	Link (fuel pump rocker arm)	1	9L,9H,OL,OH,1L,1H	49-51
49B 9381	Link (fuel pump)	1	1L,1H	51
7RA 9382	Spacer (fuel and vacuum pump rocker arm link)	1	9L,9H,OL,OH,1L,1H	49-51
8EQ 9387	Bail assy (fuel pump filter bowl)	1	9L,9H,OL,OH,1L,1H	49-51
OEL 9387-A	Bail assy (fuel pump gas strainer)	1	1L,1H	51
	59A-9167 Nut (fuel pump filter bowl bail)	1	9L,9H,OL,OH,1L,1H	49-51
59A 9388	Seat (fuel pump filter bowl)	1	9L,9H,OL,OH,1L,1H	49-51
7RA 9389	Bushing (fuel and vacuum pump rocker arm)	1	9L,9H,OL,OH,1L,1H	49-51
	352896-S Washer (fuel and vacuum pump rocker arm link spacer)	2	9L,9H,OL,OH,1L,1H	49-51
	352897-S Washer (fuel and vacuum pump rocker arm link spacer)	2	9L,9H,OL,OH,1L,1H	49-51
8EL 9396	Spring (fuel pump diaphragm)	1	9L,9H,OL,OH,1L,1H	49-51
8EL 9398-A	Diaphragm (fuel pump)	1	9L,9H,OL,OH,1L,1H	49-51
1EL 9398-A	Diaphragm and pull rod assy (fuel pump)	1	1L,1H	51
	49B-9418 Washer (fuel and vacuum pump rocker arm pin)	1	9L,9H,OL,OH,1L,1H	49-51
	7RA-9434 Retainer (fuel pump body-curved hair)	1	9L,9H,OL,OH,1L,1H	49-51
	1EL-9434-A Retainer (fuel pump body-curved hair)	1	1L,1H	51
	1BA-9468-A Retainer (fuel pump oil seal)	2	1L,1H	51
	49B-9469 Oil seal (vacuum pump diaphragm)	1	9L,9H,OL,OH,1L,1H	49-51
	8CM-9469 Oil seal (fuel pump diaphragm)	1	9L,9H,OL,OH,1L,1H	49-51
	1BA-9469-A Seal (fuel pump oil)	2	1L,1H	51
	49B-9486 Hair (fuel pump body curled)	1	1L,1H	51
	1CM-9486-A Filter (fuel pump drain)	1	9L,9H,OL,OH,1L,1H	49-51
	7RA-99355 Plate (vacuum pump cover)	1	9L,9H,OL,OH,1L,1H	49-51
	24325-S7 Bolt (hex-hd)-1/4"-28 x 5/8"- vacuum pump cover plate	1	9L,9H,OL,OH,1L,1H	49-51
	7RA-99359 Seat (vacuum pump diaphragm spring)	1	9L,9H,OL,OH,1L,1H	49-51
	8EL-99360 Kit (fuel pump strainer)-consists of the following	1	9L,9H,OL,OH,1L,1H	49-51
	(1) 8EL-9365 Strainer (1) 49B-9364 Gasket			
	7RA-99361 Plate (vacuum pump valve retainer)	1	9L,9H,OL,OH,1L,1H	49-51
	27068-S7 Screw (rd-hd)-No. 10-32 x 3/8"	1	9L,9H,OL,OH,1L,1H	49-51
	7RA-99366 Retainer (vacuum pump screen)	1	9L,9H,OL,OH,1L,1H	49-51
	7RA-99367 Gasket (vacuum pump cover plate)	1	9L,9H,OL,OH,1L,1H	49-51
	1BA-99367-A Gasket (vacuum pump valve to body)	3	1L,1H	51
	7RA-99368 Screen (vacuum pump)	1	9L,9H,OL,OH,1L,1H	49-51
	8EL-99380 Link (vacuum pump rocker arm)-R.H.	1	9L,9H,OL,OH,1L,1H	49-51
	1EL-99380-A Link (vacuum pump rocker arm)-R.H.	1	1L,1H	51
	8EL-99381 Link (vacuum pump rocker arm)-L.H.	1	9L,9H,OL,OH,1L,1H	49-51
	1EL-99381-A Link (vacuum pump rocker arm)-L.H.	1	1L,1H	51

# Lincoln and Lincoln Cosmopolitan

## CHASSIS PARTS CATALOGUE

PART NUMBER	PART NAME	NO. REQ'D	MODEL	YEAR
	8EL-99385 Body assy (vacuum pump)	1	9L,9H,OL,OH,1L,1H	49-51
	LEL-99385-A Body (vacuum pump)	1	1L,1H	51
	34803-S7 Lockwasher-No. 10	10	9L,9H,OL,OH,1L,1H	49-51
	31628-S7 Screw (fillister hd)-No. 10- 3/2 x 5/8"	10	9L,9H,OL,OH,1L,1H	49-51
	8EL-99390 Diaphragm assy (vacuum pump)	1	9L,9H,OL,OH,1L,1H	49-51
	LEL-99390-A Diaphragm assy (vacuum pump)	1	1L,1H	51
	8EL-99396 Spring (vacuum pump diaphragm)	1	9L,9H,OL,OH,1L,1H	49-51
8EL 9400-B	Rod assy (fuel pump push)	1	9L,9H,OL,OH,1L,1H	49-51
49B 9408	Gasket (fuel pump pull rod oil seal)	1	9L,9H,OL,OH,1L,1H	49-51
8EL 9413	Tube assy (vacuum pump to intake manifold)	1	9L,9H,OL,OH,1L,1H	49-51
	357979-S Elbow (inverted male hex head)- 1/2"-20 & 1/2" pipe thread x 90°-vacuum pump tube assy to intake manifold	1	9L,9H,OL,OH,1L,1H	49-51
	353245-S Elbow (inverted)-1/2"-20 & 1/8" pipe thread x 45°-vacuum tube assy to vacuum booster pump	1	9L,9H,OL,OH,1L,1H	49-51
8EQ 9416-A	Adapter (fuel pump)	1	9L,9H,OL,OH,1L,1H	49-51
	20540-S7 Bolt (hex-hd)-3/8"-16 x 2-3/8"	2	9L,9H,OL,OH,1L,1H	49-51
	24388-S8 Bolt (hex-hd)-3/8"-16 x 1"- adapter to manifold	1	9L,9H,OL,OH,1L,1H	49-51
	34807-S2 Lockwasher-3/8"-adapter to manifold	3	9L,9H,OL,OH,1L,1H	49-51
	351377-S7 Washer (flat)-3/8"-adapter to intake manifold	3	9L,9H,OL,OH,1L,1H	49-51
7RA 9417	Gasket (fuel pump adapter)-Cork-2-17/32" overall length x 1/32" thick	1	9L,9H,OL,OH,1L,1H	49-51
49B 9418	Washer (fuel and vacuum pump rocker arm pin)	1	9L,9H,OL,OH,1L,1H	49-51

## Exhaust Manifolds

8EL 9430-B	Manifold (exhaust)-RH-used on cars equipped with 8EL-5246-A and 8EH-5246-A	1	9L,9H	49
8EL 9430-C	Manifold (exhaust)-RH-used on cars equipped with 8EL-5246-B and 8EH-5246-B	1	9L,9H,OL,OH,1L,1H	49-51
8EL 9431-B	Manifold (exhaust)-LH	1	9L,9H,OL,OH,1L,1H	49-51
	24388-S8 Bolt (hex-hd)-3/8"-16 x 1"- manifold to cylinder block	12	9L,9H,OL,OH,1L,1H	49-51
	34807-S2 Lockwasher-3/8"-exhaust manifold to cylinder block	12	9L,9H,OL,OH,1L,1H	49-51
	34808-S8 Lockwasher-7/16"-exhaust manifold to crossover pipe	6	9L,9H,OL,OH,1L,1H	49-51
	356607-S2 Lockwasher (spec. flanged)-3/8" -exhaust manifold to cylinder block	12	9L,9H,OL,OH,1L,1H	49-51
	33816-S Nut (hex)-7/16"-20-exhaust manifold to crossover pipe	6	9L,9H,OL,OH,1L,1H	49-51

# Lincoln and Lincoln Cosmopolitan

## CHASSIS PARTS CATALOGUE

PART NUMBER	C S P A R T S	PART NAME	NO. REQ'D	MODEL	YEAR 19__
		<b>Exhaust Manifolds—Continued</b>			
		88413-S Stud-7/16"-20 and 7/16"-14 x 1-3/4"-LH-exhaust manifold to crossover pipe	2	9L,9H,OL,OH,1L,1H	49-51
		88413-S Stud-7/16"-20 and 7/16"-14 x 1-3/4"-RH-exhaust manifold to muffler inlet pipe	2	9L,9H,OL,OH,1L,1H	49-51
		88473-S Stud-7/16"-20 and 7/16"-14 x 2-1/2"-RH-exhaust manifold to crossover pipe	2	9L,9H,OL,OH,1L,1H	49-51
		8EL-9685-D Valve assy (exhaust thermostat)-the two stud holes in flange of body are offset from the center of the valve shaft	1	9L,9H,OL,OH,1L,1H	49-51
		8EL-9688 Spring (exhaust thermostat control valve)	1	9L,9H,OL,OH,1L,1H	49-51
8EL 9433		Kit (exhaust manifold gasket)-consists of the following (6) 7EH-9448-A Gasket (3) 8EL-9450 Gasket (1) 8EL-9453 Gasket	1	9L,9H,OL,OH,1L,1H	49-51
7RA 9434		Retainer (fuel pump body-curved hair)	1	9L,9H,OL,OH,1L,1H	49-51
1EL 9434-A		Retainer (fuel pump body-curved hair)	1	1L,1H	51
7EH 9448-A		Gasket (exhaust manifold to cylinder block)	6	9L,9H,OL,OH,1L,1H	49-51
8EL 9450		Gasket (exhaust manifold crossover pipe)	3	9L,9H,OL,OH,1L,1H	49-51
8EL 9453		Gasket (exhaust manifold to muffler inlet pipe)	1	9L,9H,OL,OH,1L,1H	49-51
LBA 9468-A		Retainer (fuel pump oil seal)	2	9L,9H,OL,OH,1L,1H	49-51
8CM 9469		Oil seal (fuel pump diaphragm)	1	9L,9H,OL,OH,1L,1H	49-51
49B 9469		Oil seal assy (vacuum pump diaphragm)	1	9L,9H,OL,OH,1L,1H	49-51
LBA 9469-A		Seal (fuel pump oil)	2	9L,9H,OL,OH,1L,1H	49-51
49B 9486		Hair (fuel pump body curled)	1	1L,1H	51
1CM 9486-A		Filter (fuel pump drain)	1	9L,9H,OL,OH,1L,1H	49-51

## Carburetor

8CM 9502		Kit (carburetor gasket)-consists of the following (1) 8CM-9516 Gasket (1) 8CM-9519 Gasket (1) 78-9535 Packing (1) 8CM-9569 Gasket (1) 8CM-9608 Gasket (1) 8CM-9853 Gasket (1) 8CM-9945 Gasket (2) 8CM-9985 Gasket (1) 8CM-9871 Gasket	1	9L,9H,OL,OH,1L,1H	49-51
*8EL 9510-A		Carburetor assy-jet size .055"-0 to 5,000 ft. altitude	1	9L,9H	49
*8EL 9510-B	NS	Carburetor assy-jet size .053"-5,000 ft. to 10,000 ft. altitude-use 8EL-9533-B in place of 8EL-9533-A to convert 8EL-9510-A to 8EL-9510-B	1	9L,9H	49
*8EL 9510-C	NS	Carburetor assy-jet size .051"-10,000 ft. to 15,000 ft. altitude-use 8EL-9533-C in place of 8EL-9533-A to convert 8EL-9510-A to 8EL-9510-C	1	9L,9H	49

\* Not used with HYDRA-MATIC transmission. Date of manufacture stamped on top of Carburetor Air Horn and Plugs Assembly will be prior to 10-48.

# Lincoln and Lincoln Cosmopolitan

## CHASSIS PARTS CATALOGUE

PART NUMBER	CLASS	PART NAME	NO. REQ'D	MODEL	YEAR
<b>Carburetor-Continued</b>					
★★8EL 9510-D	NS	Carburetor assy-jet size .055"-0 to 5,000 ft. altitude-replaced by 8EL-9510-G	1	9L,9H	49
★★8EL 9510-E	NS	Carburetor assy-jet size .053"-5,000 ft. to 10,000 ft. altitude-use 8EL-9533-B in place of 8EL-9533-A to convert 8EL-9510-D to 8EL-9510-E	1	9L,9H	49
★★8EL 9510-F	NS	Carburetor assy-jet size .051"-10,000 ft. to 15,000 ft. altitude-use 8EL-9533-C in place of 8EL-9533-A to convert 8EL-9510-D to 8EL-9510-F	1	9L,9H	49
●8EL 9510-G		Carburetor assy-jet size .055"-0 to 5,000 ft. altitude	1	9L,9H	49
●8EL 9510-H	NS	Carburetor assy-jet size .053"-5,000 to 10,000 ft. altitude-use 8EL-9533-B in place of 8EL-9533-A to convert 8EL-9510-G to 8EL-9510-H	1	9L,9H	49
●8EL 9510-J	NS	Carburetor assy-jet size .051"-10,000 to 15,000 ft. altitude-use 8EL-9533-C in place of 8EL-9533-A to convert 8EL-9510-G to 8EL-9510-J	1	9L,9H	49
●●OEL 9510-A		Carburetor assy-jet size .055"-0 to 5,000 ft. altitude-without automatic choke thermostat on side	1	0L,0H,1L,1H	50-51
●●OEL 9510-B	NS	Carburetor assy-jet size .053"-5,000 to 10,000 ft. altitude-use 8EL-9533-B in place of 8EL-9533-A to convert OEL-9510-A to OEL-9510-B-without automatic choke thermostat on side	1	0L,0H,1L,1H	50-51
●●OEL 9510-C	NS	Carburetor assy-jet size .051"-10,000 to 15,000 ft. altitude-use 8EL-9533-C in place of 8EL-9533-A to convert OEL-9510-A to OEL-9510-C-without automatic choke thermostat on side	1	0L,0H,1L,1H	50-51
		34806-S7 Lockwasher-5/16"-carburetor to intake manifold	4	9L,9H,0L,0H,1L,1H	49-51
		33798-S8 Nut (hex)-5/16"-24-carburetor to intake manifold	4	9L,9H,0L,0H,1L,1H	49-51
		89116-S7 Stud-5/16"-18 and 5/16"-24 x 1-13/16"-carburetor to intake manifold	4	9L,9H,0L,0H,1L,1H	49-51
		7EH-9603 Spacer (carburetor)-2-39/64" wide x 3-31/32" long x 1/2" thick	1	9L,9H,0L,0H,1L,1H	49-51

● Used with HYDRA-MATIC transmission. Date of manufacture stamped on top of Carburetor Air Horn and Plugs Assembly will be 6-49 to 10-49.

●● Used with HYDRA-MATIC transmission. Date of manufacture stamped on top of Carburetor Air Horn and Plugs Assembly will be 10-49 and thereafter.

★★ Not used with HYDRA-MATIC transmission. Date of manufacture stamped on top of Carburetor Air Horn and Plugs Assembly will be after 10-48, and prior to 6-49.

# Lincoln and Lincoln Cosmopolitan

## CHASSIS PARTS CATALOGUE

### Carburetor—Continued

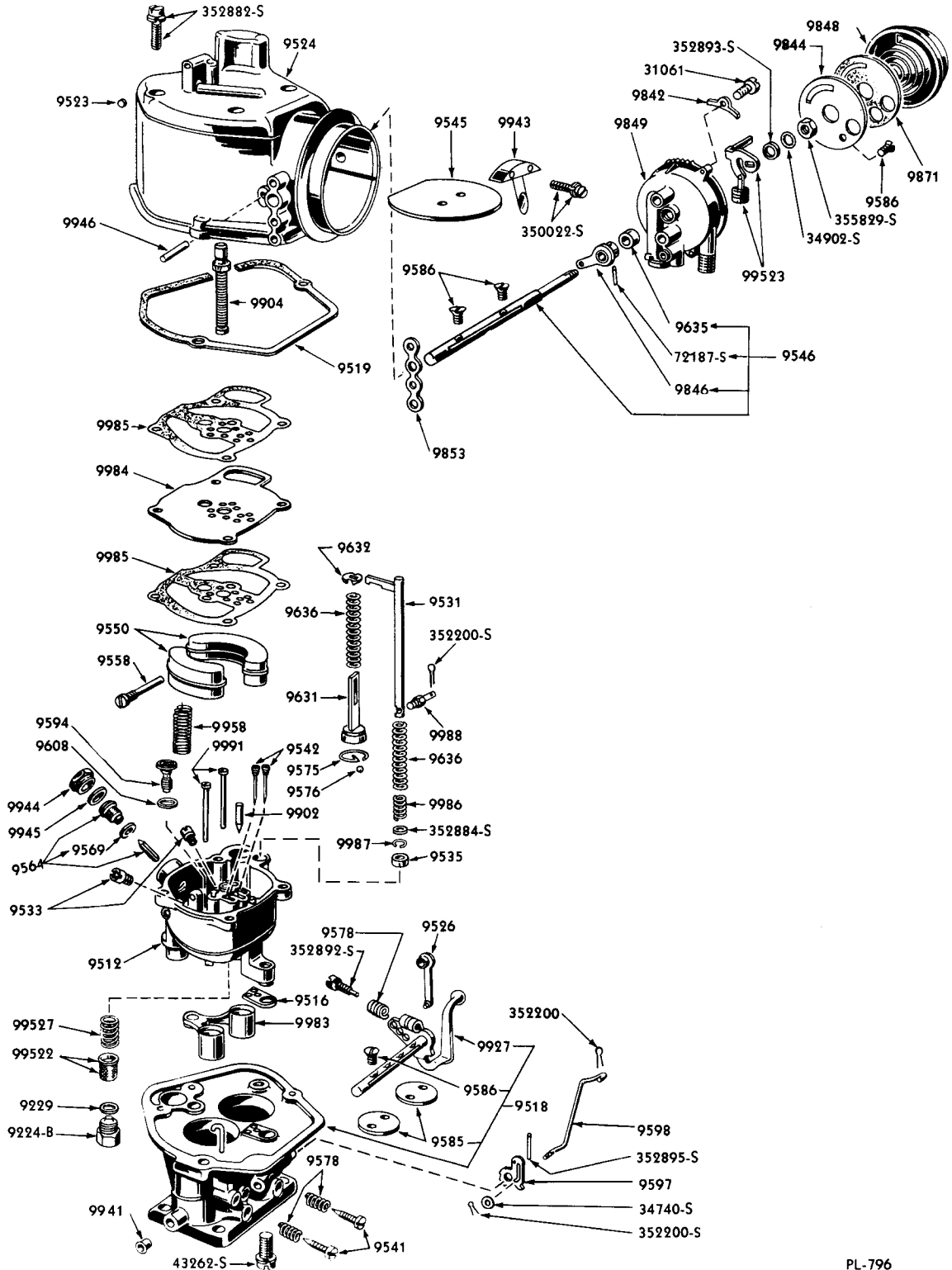

**CARBURETOR (8EL-9510-D)**

PL-796

Basic numbers only shown on illustration. Order by Part Numbers shown in list of parts.

# Lincoln and Lincoln Cosmopolitan

## CHASSIS PARTS CATALOGUE

### Carburetor—Continued

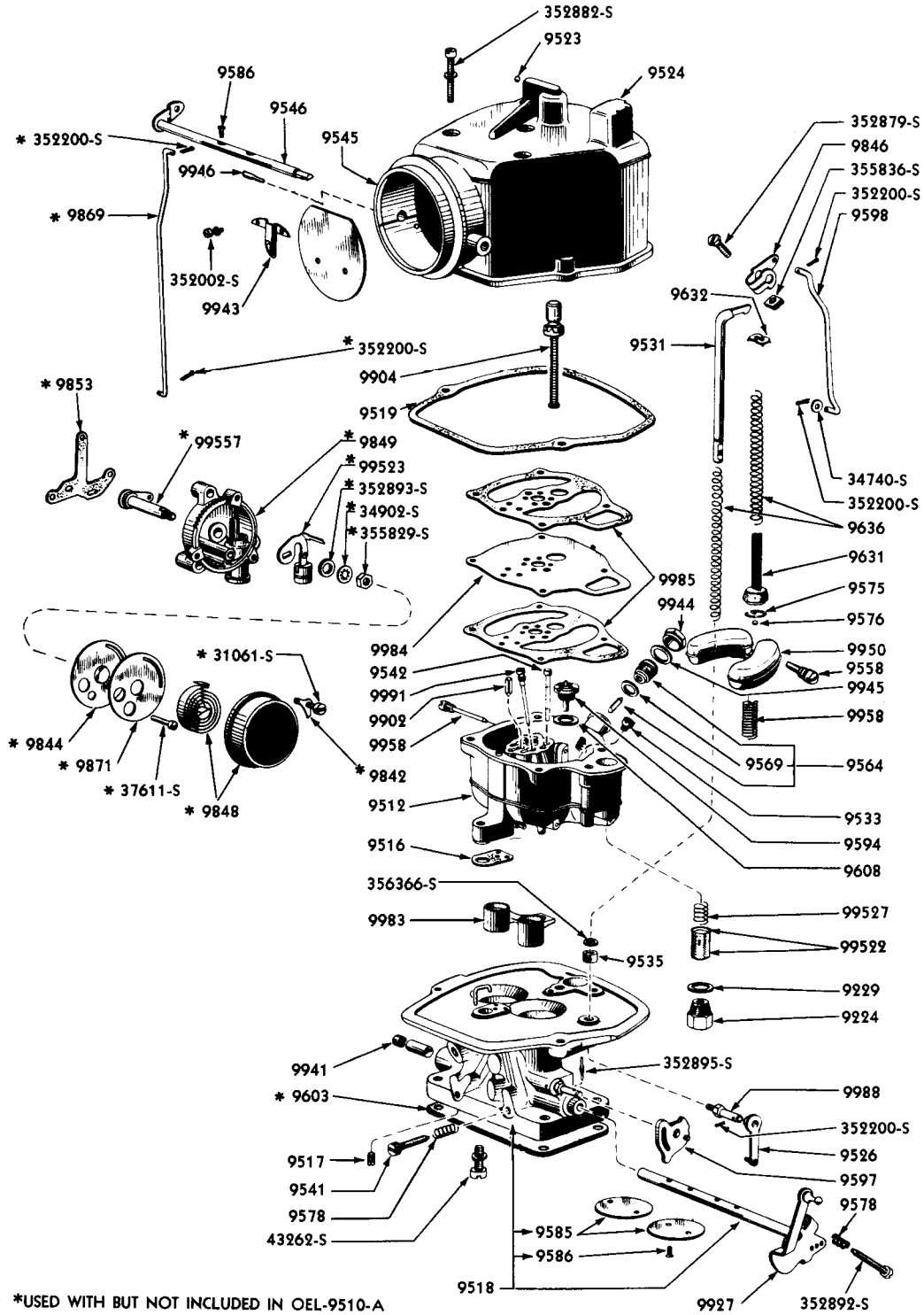

\*USED WITH BUT NOT INCLUDED IN OEL-9510-A

PL-797

### CARBURETOR (OEL-9510-A)

Basic numbers only shown on illustration. Order by Part Numbers shown in list of parts.

# Lincoln and Lincoln Cosmopolitan

## CHASSIS PARTS CATALOGUE

### Carburetor—Continued

#### CARBURETOR CHART

PART NUMBER	CLASS	PART NAME	CARBURETOR																						
			+8EL-9510-A	+8EL-9510-B	+8EL-9510-C	+8EL-9510-D	+8EL-9510-E	+8EL-9510-F	+8EL-9510-G	+8EL-9510-H	+8EL-9510-J	+0EL-9510-A	+0EL-9510-B	+0EL-9510-C											
			NUMBER REQUIRED																						
8EL 9512-A		Body and plugs assy (carburetor main)-does not use strainer	1	1	1																				
*8EL 9512-B		Body and plugs assy (carburetor main)-strainer used with this body				1	1	1	1	1	1	1	1	1	1	1	1								
8CM 9516		Gasket (carb. main body to throttle body)	1	1	1	1	1	1	1	1	1	1	1	1	1	1	1								
8CM 9517		Plug (headless-slotted)-No. 8-32 x 11/32"-distributor passage				1	1	1	1	1	1	1	1	1	1	1	1								
8EL 9518-A		Body and shaft assy (carburetor throttle)	1	1	1	1	1	1																	
8EL 9518-B		Body and shaft assy (carburetor throttle)								1	1	1													
OEL 9518		Body and shaft assy (carburetor throttle)														1	1	1							
		43262-88 Screw and lockwasher assy (fillister hd)-5/16"-24 x 7/8" long-carb. throttle body to main body	2	2	2	2	2	2	2	2	2	2	2	2	2	2	2								
		8CM-9224-B Adapter (carburetor fuel inlet)-used with 8CM-99526-7-8				1	1	1	1	1	1	1	1	1	1	1	1								
		8CM-9229 Gasket (carburetor fuel inlet adapter)-Hard Fibre-used with 8CM-9224-B				1	1	1	1	1	1	1	1	1	1	1	1								
		*B-9242 Ferrule (compression fitting)-for 1/4" O.D. pipe-used with 8EL-9819	1	1	1	1	1	1	1	1	1	1	1	1	1	1	1								
		*96H-9242 Ferrule (compression fitting)-for 5/16" O.D. pipe-used with 8EL-9820 and OEL-9820	1	1	1	1	1	1	1	1	1	1	1	1	1	1	1								
		1CM-99522 Screen & retainer assy (carburetor filter)				1				1						1									
		8CM-99526 Screen (carburetor filter)-used with 8CM-9224-B				1	1	1	1	1	1	1	1	1	1	1	1								
		8CM-99527 Spring (carburetor filter screen retainer)-used with 8CM-9224-B				1	1	1	1	1	1	1	1	1	1	1	1								
		8CM-99528 Retainer (carburetor filter spring)-used with 8CM-9224-B				1	1	1	1	1	1	1	1	1	1	1	1								
8CM 9519		Gasket assy (carb. air horn to throttle body)	1	1	1	1	1	1	1	1	1	1	1	1	1	1	1								
78 9523		Plug (carb. main body passage)-lead ball	10	10	10	10	10	10	10	10	10	10	10	10	10	10	10								

\* Fuel inlet boss is not stamped on face of boss. This unit may be identified by numeral "6" on knockout plug which is located at right front and underside of 8EL-9512-B

+ Used with HYDRA-MATIC transmission

+ + Not used with HYDRA-MATIC transmission

# Lincoln and Lincoln Cosmopolitan

## CHASSIS PARTS CATALOGUE

### Carburetor—Continued

### CARBURETOR CHART—CONTINUED

PART NUMBER	CLASS	PART NAME	CARBURETOR																
			††8EL-9510-A	††8EL-9510-B	††8EL-9510-C	††8EL-9510-D	††8EL-9510-E	††8EL-9510-F	†8EL-9510-G	†8EL-9510-H	†8EL-9510-J	†0EL-9510-A	†0EL-9510-B	†0EL-9510-C					
			NUMBER REQUIRED																
8EL 9524		Horn and plugs assy (carburetor air)	1	1	1	1	1	1	1	1	1	1	1	1					
0EL 9524		Horn and plugs assy (carburetor air)																	
		352882-S8 Screw and lockwasher assy (fill-hd)-No. 12 -24 x 15/16" long	5	5	5	5	5	5	5	5	5	5	5	5	5				
8EL 9526		Link assy (carburetor accelerator pump)	1	1	1	1	1	1	1	1	1	1	1	1	1	1			
8CM 9531-A		Rod assy (carb. accelerator pump piston operating)-used with 8CM-9636-A Spring	1	1	1														
8CM 9531-B		Rod (carb. accelerator pump piston operating)-used with 8CM-9636-B Spring				1	1	1	1	1	1	1	1	1	1				
		352884-S8 Washer (packing)-accel. & pump rod	1	1	1	1	1	1											
		356366-S Washer (flat)-5/16" I.D. x 7/16" O.D. x 1/64" thick				1	1	1	1	1	1	1	1	1	1				
8EL 9533-A		Jet (carb. main metering)-.055"-0 to 5,000 feet altitude	2			2			2			2							
8EL 9533-B		Jet (carb. main metering)-.053"-5,000 to 10,000 feet altitude		2			2			2					2				
8EL 9533-C		Jet (carb. main metering)-.051"-10,000 to 15,000 feet altitude			2			2			2						2		
78 9535		Packing (carb. accel pump operating rod) -felt-.25" I.D. x .38" O.D. x .19" thick	1	1	1	1	1	1	1	1	1	1	1	1	1	1	1		
78 9541		Needle (carburetor idle adjusting)	2	2	2	2	2	2	2	2	2	2	2	2	2	2	2		
8CM 9542		Jet assy (carburetor idling)	2	2	2	2	2	2	2	2	2	2	2	2	2	2	2		
8CM 9545		Plate (carburetor choke)	1	1	1	1	1	1	1	1	1	1	1	1	1	1	1		
		40-9586 Screw (flat hd)-No. 6-32 x 5/16"	2	2	2	2	2	2	2	2	2	2	2	2	2	2	2		
8EL 9546		Shaft and lever assy (carburetor choke)	1	1	1	1	1	1	1	1	1	1							
0EL 9546		Shaft and lever assy (carburetor choke)													1	1	1		
		34902-S7 Lockwasher (internal tooth)-No. 8	1	1	1	1	1	1	1	1	1	1							
		355829-S7 Nut (hex)-No. 8-36	1	1	1	1	1	1	1	1	1	1							
		352893-S8 Spacer-7/16" x 5/64"	1	1	1	1	1	1	1	1	1	1							
8CM 9550		Float assy (carburetor)	1	1	1	1	1	1	1	1	1	1	1	1	1	1	1		
8EL 9553		Retainer (carburetor fast idle cam)	1	1	1														
		352895-S7 Pin (grooved)-1/16" dia. -fast idle cam retainer	1	1	1	1	1	1	1	1	1	1	1	1	1	1	1		

†† Not used with HYDRA-MATIC transmission

† Used with HYDRA-MATIC transmission



# Lincoln and Lincoln Cosmopolitan

## CHASSIS PARTS CATALOGUE

### Carburetor—Continued

#### CARBURETOR CHART—CONTINUED

PART NUMBER	CLASS	PART NAME	CARBURETOR														
			+8EL-9510-A	+8EL-9510-B	+8EL-9510-C	+8EL-9510-D	+8EL-9510-E	+8EL-9510-F	+8EL-9510-G	+8EL-9510-H	+8EL-9510-J	+0EL-9510-A	+0EL-9510-B	+0EL-9510-C			
			NUMBER REQUIRED														
8CM 9558		Pin (carburetor float hinge)-No. 10-32 x 1-15/32" long	1	1	1	1	1	1	1	1	1	1	1	1			
8CM 9564	NS	Needle and seat assy (carburetor float)-repl. by 1CM-9564-A or B	1	1	1	1	1	1	1	1	1	1	1	1			
1CM 9564-A		Needle, seat, gasket and wire clip assy (carburetor float)-Steel needle	1	1	1	1	1	1	1	1	1	1	1	1			
1CM 9564-B		Needle, seat, gasket and wire clip assy (carburetor float)-Nylon needle	1	1	1	1	1	1	1	1	1	1	1	1			
8CM 9569		Gasket (carburetor float needle seat)	1	1	1	1	1	1	1	1	1	1	1	1			
78 9575		Spring (carb. accelerator pump check ball retainer)-3/4" diameter	1	1	1	1	1	1	1	1	1	1	1	1			
78 9576		Ball (carburetor accelerator pump check)-1/8" diameter	1	1	1	1	1	1	1	1	1	1	1	1			
40 9578		Spring (carb. idle adjusting needle)-3/16" diameter x 1/2" long	2	2	2	2	2	2	2	2	2	2	2	2			
1GA 9578		Spring (throttle adjusting screw)	1	1	1	1	1	1	1	1	1	1	1	1			
8CM 9585		Plate (carburetor throttle)	2	2	2	2	2	2	2	2	2	2	2	2			
40 9586		Screw (carb. choke plate)-No. 6-32 x 5/16"	2	2	2	2	2	2	2	2	2	2	2	2			
40 9586		Screw (carb. throttle plate)-No. 6-32 x 5/16"	4	4	4	4	4	4	4	4	4	4	4	4			
7RA 9588		Plug (carb. passage)-3/8"-24 x 11/64"-slotted head	1	1	1	1	1	1	1	1	1	1	1	1			
8EL 9590-A		Kit (carb. repair)-consists of the following (1)8EL-9526 Link (2) 78-9541 Needle (1)8CM-9558 Pin (1)1CM-9564-B Needle (1) 78-9575 Retainer (1) 78-9576 Ball (2) 40-9578 Spring (1)1GA-9578 Spring (6) 40-9586 Screw (1)8CM-9631 Piston (1)8CM-9902 Needle (1)8CM-9987 Retainer (1)34740-S8 Washer (2)43262-S8 Screw (3)352200-S Pin (1)352884-S8 Washer (1)352892-S8B Screw (1)352895-S8 Pin	1	1	1												
8EL 9590-B		Kit (carb. repair)-consists of the following (1)8CM-9526-A Link (2) 78-9541 Needle (1)8CM-9558 Pin (1)1CM-9564-B Needle (1) 78-9575 Retainer (1) 78-9576 Ball (2) 40-9578 Spring (1)1GA-9578 Spring (6) 40-9586 Screw (1)8CM-9631 Piston (1)8CM-9902 Needle (1)8CM-9987 Retainer (1)34740-S8 Washer (2)43262-S8 Screw (3)352200-S Pin (1)352884-S8 Washer (1)352892-S8B Screw (1)352895-S8 Pin				1	1	1									

+ Used with HYDRA-MATIC transmission

+ + Not used with HYDRA-MATIC transmission

# Lincoln and Lincoln Cosmopolitan

## CHASSIS PARTS CATALOGUE

### Carburetor—Continued

#### CARBURETOR CHART—CONTINUED

PART NUMBER	CLASS	PART NAME	CARBURETOR																
			††8EL-9510-A	††8EL-9510-B	††8EL-9510-C	††8EL-9510-D	††8EL-9510-E	††8EL-9510-F	†8EL-9510-G	†8EL-9510-H	†8EL-9510-J	†0EL-9510-A	†0EL-9510-B	†0EL-9510-C					
			NUMBER REQUIRED																
HAK 9590-A		Kit (carb. repair)-consists of the following (1)8EL-9526 Link (2) 78-9541 Needle (1)8CM-9558 Pin (1)1CM-9524-A or B Needle (1) 78-9575 Retainer (1) 78-9576 Ball (2) 40-9578 Spring (1)1GA-9578 Spring (6) 40-9586 Screw (1)8CM-9631 Piston (1)8CM-9902 Needle (1) 34740-S8 Washer (2) 43262-S8 Screw (3) 352200-S Pin (1) 352892-S8B Screw (1) 352895-S8 Pin (1) 356366-S8 Washer	1			1				1			1						
8EL 9594		Valve assy (carburetor power jet)	1	1	1	1	1	1	1	1	1	1	1	1	1				
8EL 9597-A		Cam assy (carburetor fast idle)	1	1	1	1	1	1											
8EL 9597-B		Cam assy (carburetor fast idle)								1	1	1	1	1	1				
		352895-S8 Pin (groove)-1/16" x 3/4"-fast idle cam retaining								1	1	1	1	1	1				
8CM 9598		Rod (carburetor fast idle)	1	1	1	1	1	1	1	1	1	1	1	1	1				
		352200-S Cotter pin-3/64" x 3/8"	2	2	2	2	2	2	2	2	2	2	2	2	2				
		34740-S8 Washer (flat)-No. 4	1	1	1	1	1	1	1	1	1	1	1	1	1				
		8CM-9608 Gasket (carb. power jet)	1	1	1	1	1	1	1	1	1	1	1	1	1				
		8CM-9631 Piston assy (carb. accelerator pump)	1	1	1	1	1	1	1	1	1	1	1	1	1				
		78-9632 Washer (carb. accelerator pump piston return spring retainer)	1	1	1	1	1	1	1	1	1	1	1	1	1				
		78-9636 Spring (carb. accelerator pump piston return)-.330" I.D.-22 coils	1	1	1	1	1	1	1	1	1	1	1	1	1				
		8CM-9636-A Spring (carb. accel. pump piston operating rod)-upper-.270" I.D.-17 coils-2-1/2" long-use with 8CM-9531-A	1	1	1	1	1	1	1	1	1	1	1	1	1				
		8CM-9636-B Spring (carb. accel. pump piston operating rod)-.270" I.D.-22 coils-3-3/16" long-use with 8CM-9531-B				1	1	1	1	1	1	1	1	1	1				
	NS	78-9650 Spring (carb. accel. pump piston cup expander)-1/8" O.D. x 1-9/16"	1	1	1	1	1	1	1	1	1	1	1	1	1				

†† Not used with HYDRA-MATIC transmission

† Used with HYDRA-MATIC transmission

# Lincoln and Lincoln Cosmopolitan

## CHASSIS PARTS CATALOGUE

### Carburetor—Continued

#### CARBURETOR CHART—CONTINUED

PART NUMBER	C L A S S	PART NAME	CARBURETOR																						
			††8EL-9510-A	††8EL-9510-B	††8EL-9510-C	††8EL-9510-D	††8EL-9510-E	††8EL-9510-F	††8EL-9510-G	††8EL-9510-H	††8EL-9510-J	††8EL-9510-A	††8EL-9510-B	††8EL-9510-C											
			NUMBER REQUIRED																						
		8EL-9838 Lever and link assy (carb. choke thermostat)	1	1	1	1	1	1	1	1	1														
		8CM-9840 Piston (carburetor choke)	1	1	1	1	1	1	1	1	1														
		352891-S Pin-5/64" x 9/32"	1	1	1	1	1	1	1	1	1														
		8CM-9842 Clamp (carb. automatic choke thermostat housing)	3	3	3	3	3	3	3	3	3														
		31061-S8 Screw (fillister hd)-No. 8-32 x 7/16"	3	3	3	3	3	3	3	3	3														
		8CM-9844 Plate (carb. automatic choke housing)	1	1	1	1	1	1	1	1	1														
		OEL-9844 Plate (carb. automatic choke housing)																			1	1	1		
		37611-S7 Screw (fillister head)-No. 8-32 x 1/4"	1	1	1	1	1	1	1	1	1										1	1	1		
	NS	8CM-9845 Packing (automatic choke)-graphite asbestos-replaced by 96E-9242	1	1	1	1	1	1	1	1	1														
		8EL-9846 Lever assy (carburetor choke shaft)	1	1	1	1	1	1	1	1	1														
	NS	OEL-9846 Lever (carburetor choke shaft)-replaced by OEL-9546																				1	1	1	
		72187-S7 Pin (groove)-1/16" x 1/2"-lever assy to shaft	1	1	1	1	1	1	1	1	1														
		8CM-9846 Lever (carb. automatic choke shaft)																				1	1	1	
		355836-S7 Nut (plain square)-No. 10-24-used with 8CM-9846																					1	1	1
		352879-S8 Screw (hex-hd slotted)-No. 10-24 x 5/8"-used with 8CM-9846																					1	1	1
		8EL-9848 Housing & thermostat assy (carb. automatic choke)	1	1	1	1	1	1	1	1	1											1	1	1	
	NS	8EL-9849-A Housing & plugs assy (carb. automatic choke)-with (2) screw mount holes-replaced by 8EL-9849-B	1	1	1	1	1	1	1	1	1														

†† Not used with HYDRA-MATIC transmission  
 † Used with HYDRA-MATIC transmission

# Lincoln and Lincoln Cosmopolitan

## CHASSIS PARTS CATALOGUE

### Carburetor—Continued

#### CARBURETOR CHART—CONTINUED

PART NUMBER	CLASS	PART NAME	CARBURETOR																								
			**8EL-9510-A	**8EL-9510-B	**8EL-9510-C	**8EL-9510-D	**8EL-9510-E	**8EL-9510-F	*8EL-9510-G	*8EL-9510-H	*8EL-9510-J	*0EL-9510-A	*0EL-9510-B	*0EL-9510-C													
			NUMBER REQUIRED																								
		8EL-9849-B Housing & plugs assy (carb. automatic choke)-with (3) screw mount holes										1	1	1													
		34822-S7 Lockwasher-No. 8-choke housing to body and plugs assy	1	1	1	1	1	1	1	1	1	1	1	1													
		31061-S8 Screw (fillister head)-No. 8-32 x 7/16"-choke housing to body and plugs assy	1	1	1	1	1	1	1	1	1	1	1	1													
		0EL-9849 Housing & plugs assy (carb. automatic choke)-used with 0EL-9851																			1	1	1				
		355237-S Screw (fillister head)-1/4"-20 x 1/8"-choke assy to intake manifold																		3	3	3					
		34805-S8 Washer (spring lock)-5/16"-automatic choke to intake manifold																		3	3	3					
		0EL-9851 Choke assy (automatic)-complete-attached to intake manifold																			1	1	1				
		8CM-9853 Gasket (carb. automatic choke housing to air horn)	1	1	1	1	1	1	1	1	1	1	1	1													
		*0EL-9853 Gasket (choke thermostat housing)-to intake manifold																			1	1	1				
		*0EL-9869 Rod (automatic choke thermostat)-intake manifold to carburetor																			1	1	1				
		*352200-S Cotter pin-3/64" x 3/8"-automatic choke thermostat rod																			2	2	2				
		8CM-9871 Gasket (carb. automatic choke piston housing)-Paper or Coated Fibre	1	1	1	1	1	1	1	1	1	1	1	1							1	1	1				

\* Used with but not part of Carburetor  
 \*\* Not used with HYDRA-MATIC transmission  
 + Used with HYDRA-MATIC transmission

# Lincoln and Lincoln Cosmopolitan

## CHASSIS PARTS CATALOGUE

### Carburetor—Continued

#### CARBURETOR CHART—CONTINUED

PART NUMBER	CLASS	PART NAME	CARBURETOR																
			††8EL-9510-A	††8EL-9510-B	††8EL-9510-C	††8EL-9510-D	††8EL-9510-E	††8EL-9510-F	†8EL-9510-G	†8EL-9510-H	†8EL-9510-J	†0EL-9510-A	†0EL-9510-B	†0EL-9510-C					
			NUMBER REQUIRED																
		8EL-9890-B Tube (thermostatic choke control heat)-5-29/32" overall length	1	1	1	1	1	1	1	1	1								
		0EL-9890 Tube (thermostatic choke control heat)-6-13/64" overall length											1	1	1				
		8CM-9902 Needle (carb. accelerator pump discharge)	1	1	1	1	1	1	1	1	1	1	1	1	1				
		8EL-9904-A Piston and stem assy (carburetor economizer)-stamping retainer	1	1	1														
NS		8EL-9904-B Piston & stem assy (carb. economizer)-Violet color spring-repl. by 8CM-9904-B				1	1	1	1	1	1								
		8CM-9904-B Piston & stem assy (carb. economizer)-Orange color spring	1	1	1	1	1	1	1	1	1	1	1	1	1				
		1CM-9904-A Piston & stem assy (carb. economizer)-with Red color spring											1						
		8EL-9927-A Lever and shaft assy (carburetor throttle)	1	1	1	1	1	1											
		8EL-9927-B Lever and shaft assy (carburetor throttle)									1	1	1						
		0EL-9927 Lever and shaft assy (carburetor throttle)											1	1	1				
		352895-S7 Pin (grooved)-1/16" diameter-fast idle cam retainer	1	1	1	1	1	1	1	1	1	1	1	1	1				
		352892-S8B Screw (fillister-hd)-No. 10-32 x 7/8" throttle adjusting	1	1	1	1	1	1	1	1	1	1	1	1	1				
		8BA-9941 Plug (carb. throttle boss)	1	1	1	1	1	1	1	1	1	1	1	1	1				

†† Not used with HYDRA-MATIC transmission  
 † Used with HYDRA-MATIC transmission

# Lincoln and Lincoln Cosmopolitan

## CHASSIS PARTS CATALOGUE

### Carburetor—Continued

#### CARBURETOR CHART—CONTINUED

PART NUMBER	CLASS	PART NAME	CARBURETOR														
			+8EL-9510-A	+8EL-9510-B	+8EL-9510-C	+8EL-9510-D	+8EL-9510-E	+8EL-9510-F	+8EL-9510-G	+8EL-9510-H	+8EL-9510-J	+0EL-9510-A	+0EL-9510-B	+0EL-9510-C			
			NUMBER REQUIRED														
8CM-9943-A		Tube (carb. air horn vent.) -die casting	1	1	1												
8CM-9943-B		Tube (carb. air horn vent.) -stamping				1	1	1	1	1	1	1	1				
		350022-88B Screw & lockwasher assy -No. 5-40 x 1/4"	2	2	2	2	2	2	2	2	2	2	2	2			
8CM-9944		Plug (carburetor float needle seat)	1	1	1	1	1	1	1	1	1	1	1	1			
8CM-9945		Gasket (carburetor float needle seat plug)	1	1	1	1	1	1	1	1	1	1	1	1			
8CM-9946		Pin (carb. choke plate stop)-3/4" x 3/32"-type 2 groove pin	1	1	1	1	1	1	1	1	1	1	1	1			
8CM-9958		Spring (carb. float)-1/2" O.D. x 1-3/8" long- 21 coils	1	1	1	1	1	1	1	1	1	1	1	1			
8EL-9983		Venturi (carb. secondary)	1	1	1	1	1	1	1	1	1	1	1	1			
8EL-9984		Plate (carburetor main body cover)	1	1	1	1	1	1	1	1	1	1	1	1			
8CM-9985		Gasket (carburetor main body cover plate)	2	2	2	2	2	2	2	2	2	2	2	2			
8CM-9986		Spring (carb. accelerator pump rod packing)	1	1	1	1	1	1									
8CM-9987		Ring (carb. accel. pump piston operating rod ret.)	1	1	1	1	1	1									
8CM-9988		Stud (carburetor pump operating rod)	1	1	1	1	1	1	1	1	1	1	1	1			
		352200-S Cotter pin	1	1	1	1	1	1	1	1	1	1	1	1			
8CM-9991-A		Tube assy (carb. main well) -1/8" long collar	2	2	2												
8EL-9991		Tube assy (carb. main well) -7/32" long collar				2	2	2	2	2	2	2	2	2			

++ Not used with HYDRA-MATIC transmission  
+ Used with HYDRA-MATIC transmission

# Lincoln and Lincoln Cosmopolitan

## CHASSIS PARTS CATALOGUE

### Carburetor—Continued

#### CARBURETOR CHART—CONTINUED

PART NUMBER	CLASS	PART NAME	CARBURETOR																							
			††8EL-9510-A	††8EL-9510-B	††8EL-9510-C	††8EL-9510-D	††8EL-9510-E	††8EL-9510-F	††8EL-9510-G	††8EL-9510-H	††8EL-9510-J	†OEL-9510-A	†OEL-9510-B	†OEL-9510-C												
			NUMBER REQUIRED																							
†8EL-9995-A		Kit (carb. metering repair) -0 to 5,000 ft. altitude -consists of the following (2)8EL-9533-A Jet     (2)8CM-9542 Jet (1)8EL-9594 Valve     (1)8CM-9904-B Piston (2)8CM-9991-A Tube	1	1	1																					
††8EL-9995-D		Kit (carb. metering repair) -0 to 5,000 ft. altitude -consists of the following (2)8EL-9533-A Jet     (2)8CM-9542 Jet (1)8EL-9594 Valve     (1)8CM-9904-B Piston (2)8EL-9991 Tube				1	1	1	1	1	1	1	1	1	1	1										
8EQ-9998		Gasket (carb. air horn to throttle body)-use 8EL-9519 for service														1	1	1								
1CM-99522		Screen & retainer assy (carb. filter)				1				1						1										
8EL-99523		Piston assy (automatic choke)-consists of the following-(1) 8EL-9838, (1) 8CM-9840, (1) 352891-S	1	1	1	1	1	1	1	1	1	1	1	1	1	1	1	1								
8CM-99525		Kit (carb. float and float spring)-consists of the following (1)8CM-9550 Float     (1)8CM-9958 Spring	1	1	1	1	1	1	1	1	1	1	1	1	1	1	1	1								
OEL-99557		Shaft & lever assy (choke hsg.)-used with OEL-9849														1	1	1								
34902-S8		Lockwasher (internal tooth)-No. 8														1										
355829-S7		Nut (hex)-No. 8-36														1										
352893-S8		Spacer-7/16" x 5/64"														1										

†† Use for service on 8EL-9510-E by replacing 8EL-9533-A with 8EL-9533-B, on 8EL-9510-F by replacing 8EL-9533-A with 8EL-9533-C, on 8EL-9510-H by replacing 8EL-9533-A with 8EL-9533-B and on 8EL-9510-J by replacing 8EL-9533-A with 8EL-9533-C, on OEL-9510-B by replacing 8EL 9533-A with 8EL-9533-B and on OEL-9510-C by replacing 8EL-9533-A with 8EL-9533-C

\* Use for service on 8EL-9510-B by replacing 8EL-9533-A with 8EL-9533-B and on 8EL-9510-C by replacing 8EL-9533-A with 8EL-9533-C

†† Not used with HYDRA-MATIC transmission

† Used with HYDRA-MATIC transmission

# Lincoln and Lincoln Cosmopolitan

## CHASSIS PARTS CATALOGUE

PART NUMBER	CLASS	PART NAME	NO. REQ'D	MODEL	YEAR
					19__
<b>Air Cleaner</b>					
8EL 9600		Air cleaner and silencer assy (heavy duty)	1	9L,9H,OL,OH,1L,1H	49-51
		356062-S8 Nut (hex)-7/16"-20-air cleaner to cylinder head	2	9L,9H,OL,OH,1L,1H	49-51
		8EL-9654 Gasket (air cleaner to carburetor)	1	9L,9H,OL,OH,1L,1H	49-51
		8EL-9663 Brace (air cleaner)	1	9L,9H,OL,OH,1L,1H	49-51
		OEL-99622 Gasket (air cleaner element)	1	9L,9H,OL,OH,1L,1H	49-51
7EH 9603		Spacer (carburetor)	1	9L,9H,OL,OH,1L,1H	49-51
8CM 9608		Gasket (carburetor power jet)	1	9L,9H,OL,OH,1L,1H	49-51
OCM 9628		Clamp assy (carburetor air cleaner)	1	9L,9H,OL,OH,1L,1H	49-51
		34129-S2 Nut (square)-1/4"-20	1	9L,9H,OL,OH,1L,1H	49-51
8CM 9631		Piston assy (carburetor accelerator pump)	1	9L,9H,OL,OH,1L,1H	49-51
78 9632		Washer (carb. accel. pump piston return spring ret.)	1	9L,9H,OL,OH,1L,1H	49-51
78 9636		Spring (carburetor accelerator pump piston return)-.330" I.D.-22 coils	1	9L,9H,OL,OH,1L,1H	49-51
8CM 9636-A		Spring (carb. accelerator pump piston operating rod) -upper-.270" I.D.-17 coils-used with 8CM-9531-A	1	9L,9H,OL,OH,1L,1H	49-51
8CM 9636-B		Spring (carb. accelerator pump piston operating rod) -upper-.270" I.D.-22 coils-used with 8CM-9531-B	1	9L,9H,OL,OH,1L,1H	49-51
8EL 9654		Gasket (air cleaner to carburetor)	1	9L,9H,OL,OH,1L,1H	49-51
8EL 9663		Brace (air cleaner)	1	9L,9H,OL,OH,1L,1H	49-51
8EL 9685-D		Valve assy (exhaust thermostat)	1	9L,9H,OL,OH,1L,1H	49-51
8EL 9688		Spring (exhaust thermostat control valve)	1	9L,9H,OL,OH,1L,1H	49-51

## Accelerator

PART NUMBER	CLASS	PART NAME	ACCELERATOR CHART							MODEL	YEAR 19__
			+	+	+	+	+	+	+		
			NUMBER REQUIRED								
8L-7285-C		Lever (trans. outer shifter)		1	1					9L,9H,OL,OH,1L,1H	49-51
8L-7325		Rod, nut and clevis assy (manual shift)-18-45/64" overall length		1	1					9L,OL,1L	49-51
8H-7325-B		Rod, nut and clevis assy (manual shift)-17-27/32" overall length		1	1					9H,OH,1H	49-51
		352358-S Pin (self locking)-9/32" x 61/64"		2	1	1				9L,9H,OL,OH,1L,1H	49-51
		44722-S8 Washer (flat)-5/16"		2	1	1				9L,9H,OL,OH,1L,1H	49-51
		351341-S7 Washer (flat spring)-21/64" I.D. x 5/8" O.D.		2	1	1				9L,9H,OL,OH,1L,1H	49-51
8L-7354		Clevis (manual shift rod)		1	1					9L,9H,OL,OH,1L,1H	49-51

++ Not used with HYDRA-MATIC transmission

+ Used with HYDRA-MATIC transmission

++ Used with HYDRA-MATIC transmission-engine No. 9EL-68809 and thereafter



# Lincoln and Lincoln Cosmopolitan

## CHASSIS PARTS CATALOGUE

### Accelerator—Continued

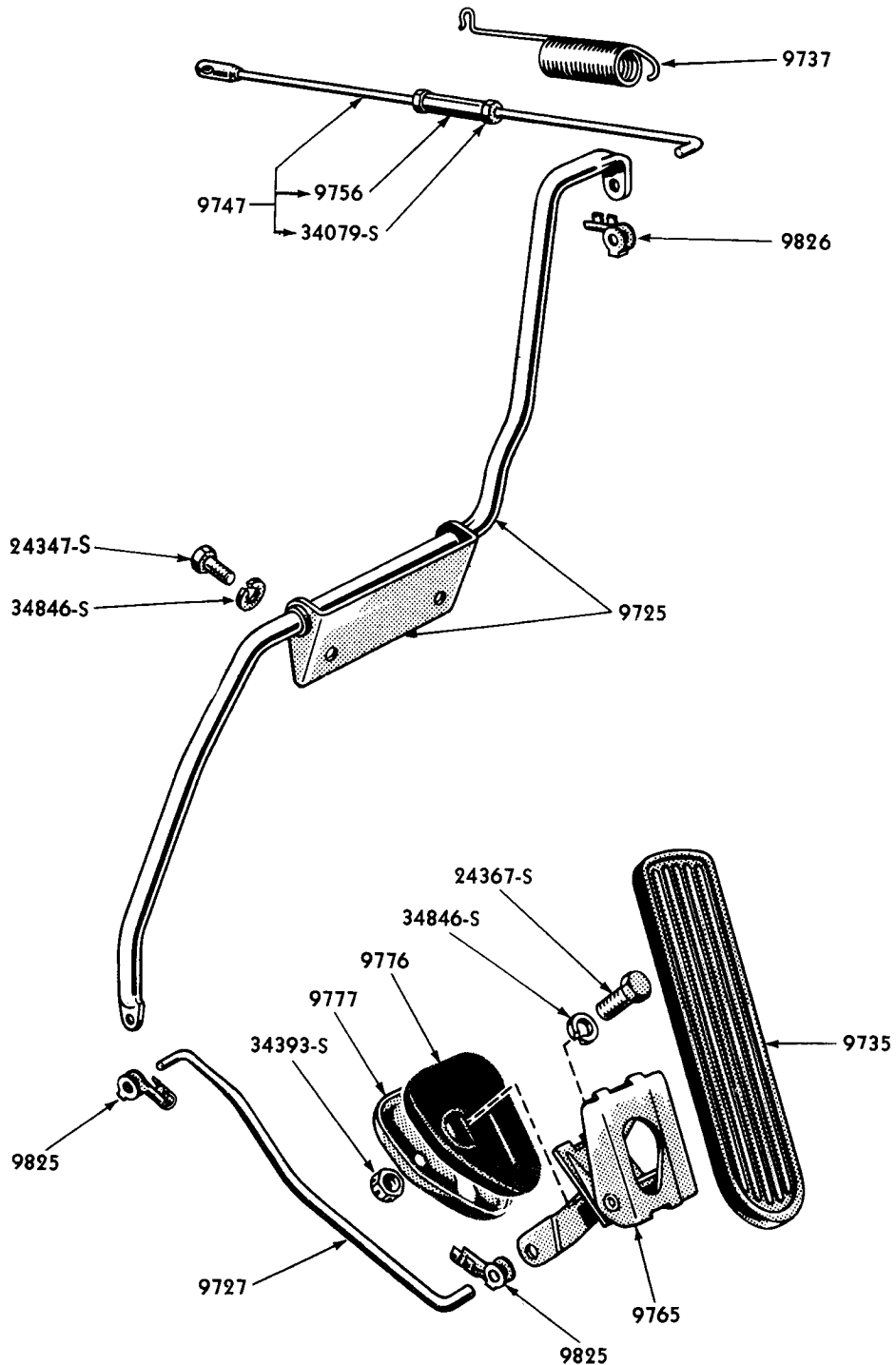

PL-810

### ACCELERATOR AND CONTROL LINKAGE (WITHOUT HYDRA-MATIC TRANSMISSION)

Basic numbers only shown on illustration. Order by Part Numbers shown in list of parts.

# Lincoln and Lincoln Cosmopolitan

## CHASSIS PARTS CATALOGUE

### Accelerator—Continued

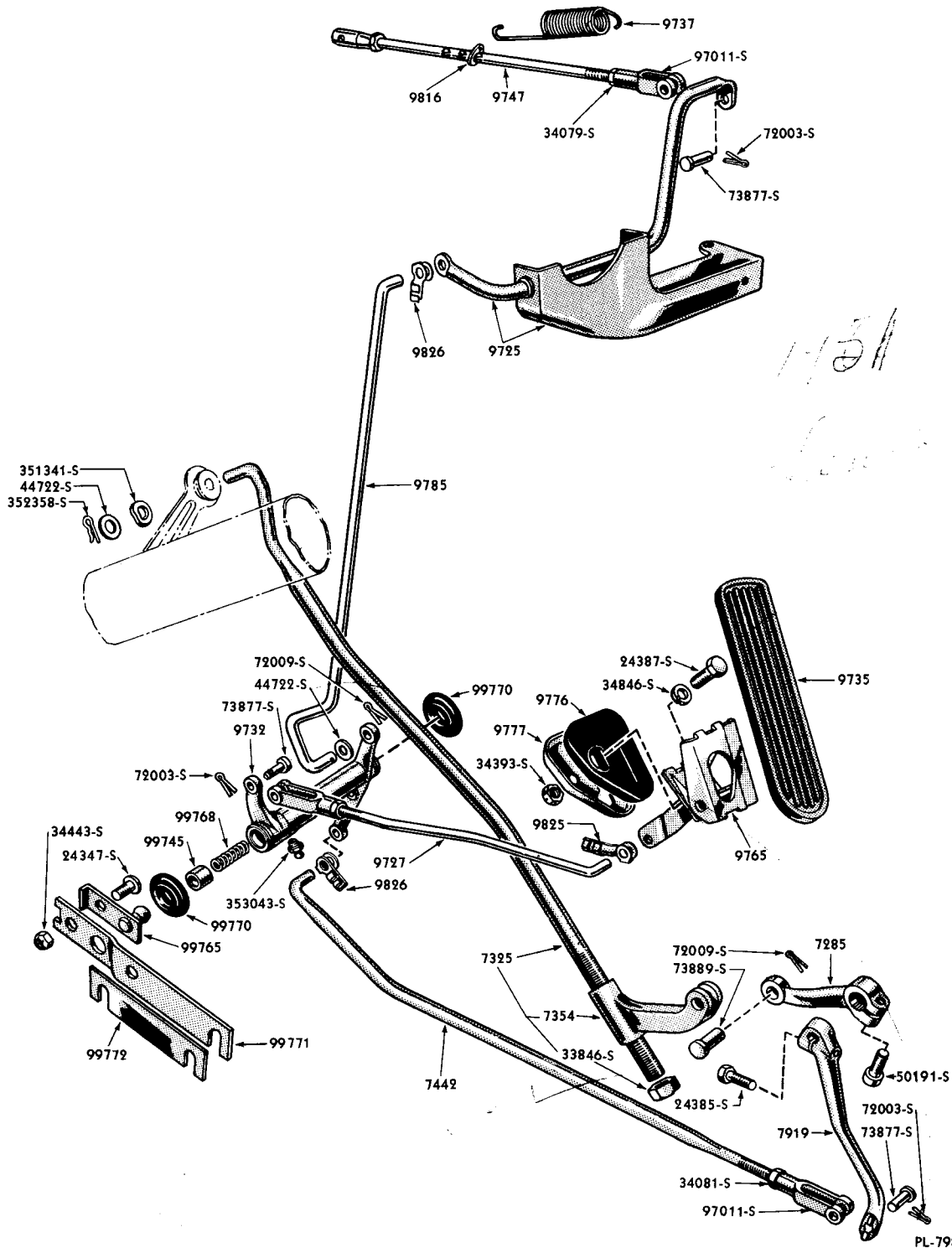

**ACCELERATOR AND CONTROL LINKAGE (UP TO AND INCLUDING ENGINE NO. 9EL-68808 WITH HYDRA-MATIC TRANSMISSION)**

Basic numbers only shown on illustration. Order by Part Numbers shown in list of parts.

# Lincoln and Lincoln Cosmopolitan

## CHASSIS PARTS CATALOGUE

### Accelerator—Continued

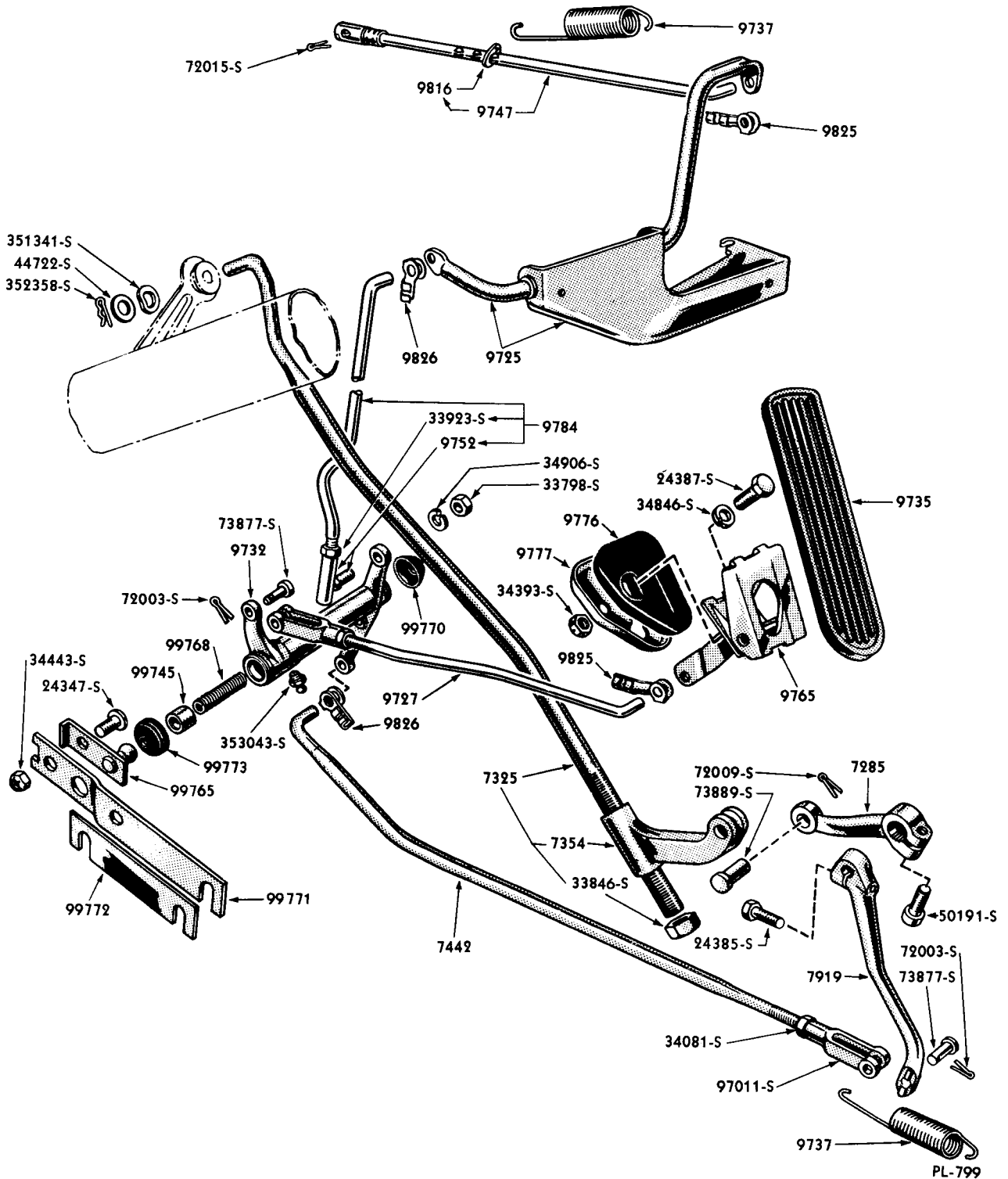

**ACCELERATOR AND CONTROL LINKAGE (ENGINE NO. 9EL-68809 AND THEREAFTER—WITH HYDRA-MATIC TRANSMISSION)**

Basic numbers only shown on illustration. Order by Part Numbers shown in list of parts.

# Lincoln and Lincoln Cosmopolitan

## CHASSIS PARTS CATALOGUE

### Accelerator—Continued

#### ACCELERATOR CHART—CONTINUED

PART NUMBER	CLASS	PART NAME	ACCELERATOR						MODEL	YEAR 19
			++	+	++					
			NUMBER REQUIRED							
		72009-S Cotter pin-3/32" x 5/8"		1	1				9L, 9H, 0L, 0H, 1L, 1H	49-51
		33846-S2 Nut (hex)-1/2"-20		1	1				9L, 9H, 0L, 0H, 1L, 1H	49-51
		73889-S7 Pin (clevis)-3/8" x 7/8"		1	1				9L, 9H, 0L, 0H, 1L, 1H	49-51
		8L-7442-A Rod, nut and clevis assy (bell crank to valve shift lever)-22-1/8" o/all length (rod only)		1					9L, 9H	49
		8L-7442-B Rod, nut and clevis assy (bell crank to valve shift lever)-21-3/4" o/all length (rod only)			1				9L, 9H, 0L, 0H, 1L, 1H	49-51
		97011-S7 Clevis-1/4"-28 x 2"		1	1				9L, 9H, 0L, 0H, 1L, 1H	49-51
		72003-S7 Cotter pin-1/16" x 1/2"		1	1				9L, 9H, 0L, 0H, 1L, 1H	49-51
		34081-S7 Nut (hex)-1/4"-28		1	1				9L, 9H, 0L, 0H, 1L, 1H	49-51
		73877-S7 Pin (clevis)-1/4" x 25/32"		1	1				9L, 9H, 0L, 0H, 1L, 1H	49-51
		8L-7919 Lever (trans. throttle control outer)		1	1				9L, 9H, 0L, 0H, 1L, 1H	49-51
		24385-S2 Bolt (hex-hd)-1/4"-28 x 1"-attaches 8L-7919 to throttle control shaft		1	1				9L, 9H, 0L, 0H, 1L, 1H	49-51
8H 9725-A		Rod and bracket assy (accelerator "Z")		1					9H, 0H, 1H	49-51
8L 9725-A		Rod and bracket assy (accelerator "Z")		1					9L, 0L, 1L	49-51
		24347-S8 Bolt (hex-hd)-5/16"-24 x 3/4"-accel. assy to dash panel		2					9L, 9H	49
		34846-S2 Lockwasher-5/16"-accel. assy to dash panel		2					9L, 9H	49
		33798-S8 Nut (hex)-5/16"-24- accel. assy to dash panel		2					9L, 9H	49
		351359-S7 Washer (flat)-5/16"- accel. assy to dash panel		2					9H	49
8L 9725-B		Shaft and bracket assy (accelerator)-with 4" long x 27/32" deep cutout between shaft and bracket mounting ears		1					9L, 9H	49
8L 9725-C		Shaft and bracket assy (accelerator)-without 4" x 27/32" deep cutout between shaft to bracket mounting ears			1				9L, 9H, 0L, 0H, 1L, 1H	49-51
		20418-S7 Bolt (hex-hd)-3/8"-16 x 1-3/16"-accel. shaft brkt. to intake manifold		1	1				9L, 9H, 0L, 0H, 1L, 1H	49-51
		20540-S7 Bolt (hex-hd)-3/8"-16 x 2-3/8"-accel. shaft brkt. to fuel pump adapter		1	1				9L, 9H, 0L, 0H, 1L, 1H	49-51
		34907-S7 Lockwasher (internal tooth)-3/8"-accelerator shaft brkt. to fuel pump adapter		2	2				9L, 9H, 0L, 0H, 1L, 1H	49-51
		44726-S8 Washer (flat)-3/8"-8L-9725-C to manifold			1				9L, 9H, 0L, 0H, 1L, 1H	49-51

++ Not used with HYDRA-MATIC transmission

+ Used with HYDRA-MATIC transmission up to and including engine No. 9EL-68808

++ Used with HYDRA-MATIC transmission engine No. 9EL-68809 and thereafter

# Lincoln and Lincoln Cosmopolitan

## CHASSIS PARTS CATALOGUE

### Accelerator—Continued

#### ACCELERATOR CHART—CONTINUED

PART NUMBER	CLASS	PART NAME	ACCELERATOR							MODEL	YEAR 19
			++	+	+	+	+	+	+		
			NUMBER REQUIRED								
8M 9727-A		Rod (accelerator shaft to accel. pedal)-7-11/32" overall length, not threaded at ends-used with 8M-9735-A pedal and clip assy	1							9L, 9H	49
8L 9727-A		Rod (accel. shaft to accel. pedal)-approx. 8-3/32" overall length-used with 8M-9735-B pedal assy	1							9L, 9H, 0L, 0H, 1L, 1H	49-51
8L 9727-B		Rod, nut and clevis assy (accel. pedal to bell crank)-10-9/32" overall length		1						9L	49
8I. 9727-C		Rod, nut and clevis assy (accel. pedal to bell crank)-9-31/32" overall length				1				9L, 0L, 1L	49-51
8H 9727-A		Rod, nut and clevis assy (accelerator pedal to bell crank)-11-7/32" overall length	1							9H	49
8H 9727-B		Rod, nut and clevis assy (accelerator pedal to bell crank)-10-29/32" overall length				1				9H, 0H, 1H	49-51
		97011-S7 Clevis-1/4"-28 x 2"	1	1						9L, 9H, 0L, 0H, 1L, 1H	49-51
		72003-S7 Cotter pin-1/16" x 1/2"	1	1						9L, 9H, 0L, 0H, 1L, 1H	49-51
		34081-S7 Nut (hex)-1/4"-28	1	1						9L, 9H, 0L, 0H, 1L, 1H	49-51
		73877-S7 Pin (clevis)-1/4" x 25/32"	1	1						9L, 9H, 0L, 0H, 1L, 1H	49-51
8L 9732-B		Bell crank (accelerator)-linkage adj. pin hole is in center of bell crank lever	1							9L, 9H	49
8L 9732-C		Bell crank (accelerator)-linkage adj. pin hole is near edge of bell crank lever				1				9L, 9H, 0L, 0H, 1L, 1H	49-51
		353043-AS7 Fitting (lubricator)-straight-1/4"-28	1	1						9L, 9H, 0L, 0H, 1L, 1H	49-51
8M 9735-A		Pedal, pad and clip assy (accelerator)-9" long x 2-11/32" wide	1							9L, 9H	49
8M 9735-B		Pedal, pad and clip assy (accelerator)-8-45/64" long x 2" wide	1	1						9L, 9H, 0L, 0H, 1L, 1H	49-51
HAK 9735-A		Kit (accel. pedal extension)-consists of the following (1) 1H-9735-A Pedal (2) 32690-S Screw	1	1	1					9L, 9H, 0L, 0H, 1L, 1H	49-51
8M 9737-A		Spring (accelerator pedal retracting)-has 38 coils-3/4" dia. x approx. 10-1/2" overall free length	1							9L, 9H, 0L, 0H, 1L, 1H	49-51
8L 9737		Spring (accelerator pedal retracting)-4" approx. free length-36 coils-8L-9747-B & C Rod assy to dash		1	1					9L, 9H, 0L, 0H, 1L, 1H	49-51
8L 9737		Spring (throttle control outer lever to frame)-4" approximate free length-36 coils				1				9L, 9H, 0L, 0H, 1L, 1H	49-51

++ Not used with HYDRA-MATIC transmission

+ Used with HYDRA-MATIC transmission up to and including engine No. 9EL-68808

++ Used with HYDRA-MATIC transmission engine No. 9EL-68809 and thereafter

# Lincoln and Lincoln Cosmopolitan

## CHASSIS PARTS CATALOGUE

### Accelerator—Continued

#### ACCELERATOR CHART—CONTINUED

PART NUMBER	CLASS	PART NAME	ACCELERATOR						MODEL	YEAR 19
			++	+	++					
			NUMBER REQUIRED							
8L 9747-A		Rod assy (accelerator shaft to carburetor)-with turn buckle (06H-9756) at center of rod	1						9L, 9H, OL, OH, 1L, 1H	49-51
8L 9747-B		Rod, nut and clevis assy (accelerator shaft and bracket to carburetor)-has clevis on end attaching to accelerator shaft		1					9L, 9H	49
8L 9747-C		Rod assy (accelerator shaft and bracket to carb.)-without clevis and nut at end or turn buckle at center of rod			1				9L, 9H, OL, OH, 1L, 1H	49-51
		8L-9737 Spring (accel. pedal retracting) -to provide tension from rod assy (8L-9747-C) to dash panel			1				9L, 9H, OL, OH, 1L, 1H	49-51
		8L-9816 Clip (accel. pedal retracting spring)	1	1	1				9L, 9H, OL, OH, 1L, 1H	49-51
		97011-S7 Clevis-1/4"-28 x 2"	1	1					9L, 9H	49
		72003-S7 Cotter pin-1/16" x 1/2"	1	1					9L, 9H	49
		34079-S7 Nut (hex)-No. 10-32-adj. locknut on accel. shaft to carburetor rod assy	2						9L, 9H, OL, OH, 1L, 1H	49-51
		72015-S Cotter pin-1/16" x 5/8"-used with 8L-9747-C to carburetor arm	1	1	1				9L, 9H, OL, OH, 1L, 1H	49-51
		73877-S7 Pin (clevis)-1/4" x 25/32"	1	1					9L, 9H	49
8L 9752		Ball joint assy (bellcrank to accel. shaft)			1				OL, OH, 1L, 1H	50-51
06H 9756		Nut (accelerator shaft to pedal rod adjusting)-No. 10-32-used with 8L-9747-A	1						9L, 9H, OL, OH, 1L, 1H	49-51
8M 9765-A		Hinge and lever assy (accelerator pedal)	1						9L, 9H	49
8M 9765-B		Hinge and lever assy (accelerator pedal)		1	1				9L, 9H, OL, OH, 1L, 1H	49-51
		24387-S7 Bolt (hex head)-5/16"-24 x 1" hinge & lever assy to floor	1	1	1				9L, 9H, OL, OH, 1L, 1H	49-51
		34393-S7 Locknut (hex)-5/16"-24-hinge & lever assy to pedal	1	1	1				9L, 9H, OL, OH, 1L, 1H	49-51
		34846-S2 Lockwasher-5/16"	1	1	1				9L, 9H, OL, OH, 1L, 1H	49-51
8M 9776		Shield (accelerator pedal dust)-Rubber	1	1	1				9L, 9H, OL, OH, 1L, 1H	49-51
8M 9777		Cover (accelerator pedal dust shield)	1	1	1				9L, 9H, OL, OH, 1L, 1H	49-51
8L 9784		Rod assy (bell crank to accelerator)			1				9L, 9H, OL, OH, 1L, 1H	49-51
		8L-9752 Ball joint assy (bell crank to accelerator shaft)			1				9L, 9H, OL, OH, 1L, 1H	49-51
		34906-S8 Lockwasher-5/16"-bell crank to accel. shaft rod assy to accel. bell crank-used with 8L-9784			1				9L, 9H, OL, OH, 1L, 1H	49-51

++ Not used with HYDRA-MATIC transmission

+ Used with HYDRA-MATIC transmission up to and including engine No. 9EL-68808

++ Used with HYDRA-MATIC engine No. 9EL-68809 and thereafter

# Lincoln and Lincoln Cosmopolitan

## CHASSIS PARTS CATALOGUE

### Accelerator—Continued

#### ACCELERATOR CHART—CONTINUED

PART NUMBER	CLASS	PART NAME	ACCELERATOR						MODEL	YEAR 19
			++	+	++					
			NUMBER REQUIRED							
		33798-S8 Nut (hex)-5/16"-24-bell crank to accel. shaft rod assy to accel. bell crank-used with 8L-9784			1				9L, 9H, 0L, 0H, 1L, 1H	49-51
		33923-S7 Nut (hex check)-5/16"-24 bell crank to accel. shaft rod assy-used with 8L-9784			1				9L, 9H, 0L, 0H, 1L, 1H	49-51
8L 9785-A		Rod (accelerator shaft and bracket to bell crank)-16-5/64" overall length		1					9L, 9H	49
		72009-S Cotter pin-3/32" x 5/8"	1	1					9L, 9H	49
		44722-S8 Washer (flat)-5/16"-replaces 34746-S2	1	1	1				9L, 9H	49
B 9794-A		Cup (accelerator shaft bracket)-Rubber-use 8L-99770-B		2					9L, 9H	49
8L 9816		Clip (accelerator pedal retracting spring)	1	1	1				9L, 9H, 0L, 0H, 1L, 1H	49-51
		59A-9825-A Clip (rod end clevis)-RH-for 3/16" dia. rod	as req	as req	as req				9L, 9H, 0L, 0H, 1L, 1H	49-51
		8M-9825 Clip (rod end clevis)-RH-for 1/4" dia. rod	as req	as req	as req				9L, 9H, 0L, 0H, 1L, 1H	49-51
		59A-9826-A Clip (rod end clevis)-LH-for 3/16" dia. rod	as req	as req	as req				9L, 9H, 0L, 0H, 1L, 1H	49-51
		8M-9826 Clip (rod end clevis)-LH-for 1/4" dia. rod	as req	as req	as req				9L, 9H, 0L, 0H, 1L, 1H	49-51
		8L-99745 Bushing (accel. bell crank stud)		1	1				9L, 9H, 0L, 0H, 1L, 1H	49-51
		8L-99765-B Plate and stud assy (accelerator bell crank)		1	1				9L, 9H, 0L, 0H, 1L, 1H	49-51
		20347-S2 Bolt (hex-hd)-5/16"-24 x 3/4" -attaches stud 8L-99765-B to frame		1	1				9L, 9H, 0L, 0H, 1L, 1H	49-51
		24347-S8 Bolt (hex-hd)-5/16"-24 x 3/4" -attaches 8L-99765-B to 8L-99771		1	1				9L, 9H, 0L, 0H, 1L, 1H	49-51
		34443-S7 Locknut (hex)-5/16"-24		1	1				9L, 9H, 0L, 0H, 1L, 1H	49-51
		8L-99768-B Spring (accel. bell crank)- approx. 1-9/16" free length		1	1				9L, 9H, 0L, 0H, 1L, 1H	49-51
		8L-99770-B Seal (accelerator bell crank)		2	2				9L, 9H	49
		0L-99770 Seal (accelerator bell crank)- inner			1				0L, 0H, 1L, 1H	50-51
		8L-99771 Bracket (accel. bell crank)- outer-approximately 6-1/8" overall length		1	1				9L, 0L, 1L	49-51

++ Not used with HYDRA-MATIC transmission

+ Used with HYDRA-MATIC transmission up to and including engine No. 9EL-68808

\*\* Used with HYDRA-MATIC transmission-engine No. 9EL-68809 and thereafter

# Lincoln and Lincoln Cosmopolitan

## CHASSIS PARTS CATALOGUE

### Accelerator-Continued

#### ACCELERATOR CHART-CONTINUED

PART NUMBER	CLASS	PART NAME	ACCELERATOR						MODEL	YEAR 19
			◆◆	◆	◆◆					
			NUMBER REQUIRED							
		8H-99771 Bracket (accel. bell crank)- outer-approximately 6-23/32" overall length		1	1				9H, 9H, 1H	49-51
		8L-99772-A Shim (accel. bell crank bracket) -outer-Steel-.0299" thick		as req	as req				9L, 9H, 9L, 9H, 1L, 1H	49-51
		8L-99772-B Shim (accel. bell crank bracket) -outer-Steel-.0598" thick		as req	as req				9L, 9H, 9L, 9H, 1L, 1H	49-51
		8L-99772-C Shim (accel. bell crank bracket) -outer-Steel-.1196" thick		as req	as req				9L, 9H, 9L, 9H, 1L, 1H	49-51
		9L-99773 Seal (accelerator bell crank)- outer				1			9L, 9H, 1L, 1H	50-51

PART NUMBER	CLASS	PART NAME	NO. REQ'D	MODEL	YEAR 19
8EL 9819		Tube (thermostat choke control)-outlet	1	9L, 9H, 9L, 9H, 1L, 1H	49-51
8EL 9820		Tube (thermostat choke control)-inlet	1	9L, 9H	49
OEL 9820		Tube (thermostat choke control)-inlet	1	9L, 9H, 1L, 1H	50-51
59A 9825-A		Clip (rod end clevis)-RH-for 3/16" dia. rod	as reqd	9L, 9H, 9L, 9H, 1L, 1H	49-51
8M 9825		Clip (rod end clevis)-RH-for 1/4" dia. rod	as reqd	9L, 9H, 9L, 9H, 1L, 1H	49-51
59A 9826-A		Clip (rod end clevis)-LH-for 3/16" dia. rod	as reqd	9L, 9H, 9L, 9H, 1L, 1H	49-51
8M 9826		Clip (rod end clevis)-LH-for 1/4" dia. rod	as reqd	9L, 9H, 9L, 9H, 1L, 1H	49-51
8EL 9838		Lever and link assy (carburetor choke thermostat)	1	9L, 9H, 9L, 9H, 1L, 1H	49-51
8CM 9840		Piston (carburetor choke)	1	9L, 9H, 9L, 9H, 1L, 1H	49-51
8CM 9842		Clamp (carb. automatic choke thermostat housing)	3	9L, 9H, 9L, 9H, 1L, 1H	49-51
8CM 9844		Plate (carburetor automatic choke housing)	1	9L, 9H	49
OEL 9844		Plate (carburetor automatic choke housing)	1	9L, 9H, 1L, 1H	50-51
8CM 9845	NS	Packing (automatic choke)-graphite asbestos- replaced by 96H-9242	1	9L, 9H, 9L, 9H	49-50
8EL 9846		Lever assy (carburetor choke shaft)	1	9L, 9H	49
OEL 9846	NS	Lever (carburetor choke shaft)-replaced by OEL-9546	1	9L, 9H	50
8CM 9846		Lever (carburetor automatic choke)	1	9L, 9H, 1L, 1H	50-51
8EL 9848		Housing & thermostat assy (carb. automatic choke)	1	9L, 9H, 9L, 9H, 1L, 1H	49-51
8EL 9849-A	NS	Housing and plugs assy (carb. automatic choke)- replaced by 8EL-9849-B	1	9L, 9H, 9L, 9H, 1L, 1H	49-51
8EL 9849-B		Housing and plugs assy (carb. automatic choke)	1	9L, 9H, 9L, 9H, 1L, 1H	49-51
OEL 9849		Housing and plugs assy (carb. automatic choke)	1	9L, 9H, 1L, 1H	50-51

◆◆ Not used with HYDRA-MATIC transmission

◆ Used with HYDRA-MATIC transmission up to and including engine No. 9EL-68808

◆◆ Used with HYDRA-MATIC transmission engine No. 9EL-68809 and thereafter



# Lincoln and Lincoln Cosmopolitan

## CHASSIS PARTS CATALOGUE

PART NUMBER	PART NAME	NO. REQ'D	MODEL	YEAR 19__
<b>Accelerator-Continued</b>				
OEL 9851	Choke assy (automatic)-complete-attached to intake manifold	1	OL,OH,LL,1H	50-51
8CM 9853	Gasket (carb. automatic choke housing to air horn)	1	9L,9H	49
OEL 9853	Gasket (choke thermostat housing)	1	OL,OH,LL,1H	50-51
OEL 9869	Rod (automatic choke thermostat)	1	OL,OH,LL,1H	50-51
8CM 9871	Gasket (carb. automatic choke piston housing)	1	9L,9H,OL,OH,LL,1H	49-51
8CM 9877-C	Elbow (thermostatic choke control tube)-inlet	1	9L,9H,OL,OH,LL,1H	49-51
8CM 9884-C	Elbow (thermostatic choke control tube)-outlet	1	9L,9H	49
OEL 9888	Bushing (heat tube to intake manifold)-Brass-5/16" and 3/8" O.D. x 5/16" long-with 7/32" diameter hole	1	OL,OH,LL,1H	50-51
8EL 9890-B	Tube (thermostatic choke control heat)-5-29/32" overall length	1	9L,9H	49
OEL 9890	Tube (thermostatic choke control heat)-6-13/64" overall length	1	OL,OH,LL,1H	50-51
8CM 9902	Needle (carburetor accelerator pump discharge)	1	9L,9H,OL,OH,LL,1H	49-51
8CM 9904-B	Piston and stem assy (carb. economizer)-Orange color spring	1	9L,9H,OL,OH,LL,1H	49-51
1CM 9904-A	Piston and stem assy (carb. economizer)-with Red color spring	1	OL,OH,LL,1H	50-51
••8EL 9904-A	Piston and stem assy (carburetor economizer)-stamping retainer	1	9L,9H	49
•8EL 9904-B	Piston and stem assy (carb. economizer)-Violet color spring	1	9L,9H	49
++8EL 9927-A	Lever and shaft assy (carburetor throttle)	1	9L,9H	49
+8EL 9927-B	Lever and shaft assy (carburetor throttle)	1	9L,9H	49
+OEL 9927	Lever and shaft assy (carburetor throttle)	1	OL,OH,LL,1H	50-51
8BA 9941	Plug (carburetor throttle boss)	1	9L,9H,OL,OH,LL,1H	49-51
8CM 9943-B	Tube (carburetor air horn vent)-stamping	1	9L,9H,OL,OH,LL,1H	49-51
8CM 9944	Plug (carburetor float needle seat)	1	9L,9H,OL,OH,LL,1H	49-51
8CM 9945	Gasket (carb. float needle seat plug)	1	9L,9H,OL,OH,LL,1H	49-51
8CM 9946	Pin (groove)-3/4" x 3/432"-type 2-carb. choke plate stop	1	9L,9H,OL,OH,LL,1H	49-51
8CM 9958	Spring (carburetor float)	1	9L,9H,OL,OH,LL,1H	49-51
8EL 9983	Venturi (carburetor secondary)	1	9L,9H,OL,OH,LL,1H	49-51
8EL 9984	Plate (carburetor main body cover)	1	9L,9H,OL,OH,LL,1H	49-51
8CM 9985	Gasket (carburetor main body cover plate)	2	9L,9H,OL,OH,LL,1H	49-51
++8CM 9986	Spring (carburetor accelerator pump rod packing)	1	9L,9H	49
++8CM 9987	Ring (carb. accel. pump piston operating rod ret.)	1	9L,9H	49
8CM 9988	Stud (carburetor pump operating rod)	1	9L,9H,OL,OH,LL,1H	49-51
••8CM 9991-A	Tube assy (carburetor main well)	2	9L,9H	49
•8EL 9991	Tube assy (carburetor main well)	2	9L,9H,OL,OH,LL,1H	49-51
••8EL 9995-A	Kit (carb. metering repair)-0 to 5,000 ft. alt.	1	9L,9H	49
•8EL 9995-D	Kit (carb. metering repair)-0 to 5,000 ft. alt.	1	9L,9H,OL,OH,LL,1H	49-51

•• Used with 8EL-9510-A, B or C Carburetors

• Used with 8EL-9510-D, E, F, G, H and J Carburetors also OEL-9510-A, B and C Carburetors

++ Not used with HYDRA-MATIC transmission

+ Used with HYDRA-MATIC transmission

# Lincoln and Lincoln Cosmopolitan

## CHASSIS PARTS CATALOGUE

### Generator

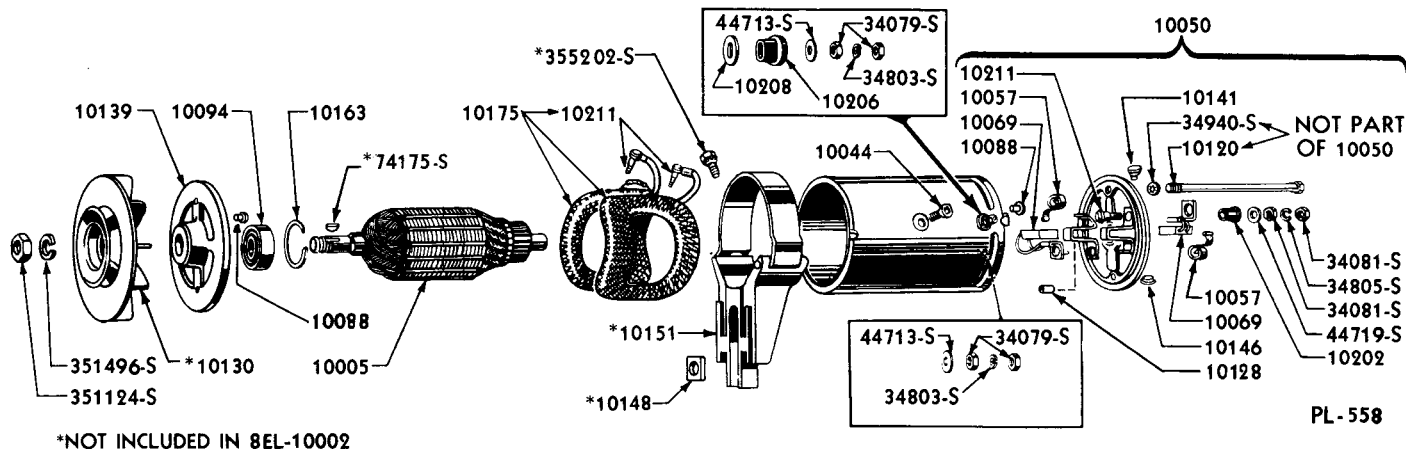

### GENERATOR (8EL-10002-A)

Basic numbers only shown on illustration. Order by Part Numbers shown in list of parts.

PART NUMBER	QTY	PART NAME	NO. REQ'D	MODEL	YEAR 19__
8EL-8620-A		Belt (generator and water pumps)- 3/4" wide	1	9L,9H	49
8EL-8620-B		Belt (generator and water pumps)- 3/4" wide-used with 60 amp. gen.	1	9L,9H	49
8EL-8620-D		Belt (generator and LH water pumps) -29/64" wide	1	9L,9H,0L,0H,1L,1H	49-51
8EL-8620-F		Belt (generator and LH water pump)- 29/64" wide-used with 60 amp.gen.	1	0L,0H,1L,1H	50-51
8EL 10002-A	NS	Generator assy (less pulley, bracket and bolt)-40 amps.-two brush type-replaced by 8EL-10002-B	1	9L,9H,0L,0H	49-50
8EL 10002-B		Generator assy (less pulley, bracket and bolt)-40 amps.-two brush type-use with 8L-10505	1	9L,9H,0L,0H,1L,1H	49-51
8BA 10002-C		Generator assy (less pulley, bracket and bolt)-60 amps.-four brush type-heavy duty-use with 8BA-10505-A	1	9L,9H,0L,0H,1L,1H	49-51
OM 10002		Generator assy (less pulley, bracket and bolt)-32 amps.-two brush type-for low speed output- use with 8A-10505-A	1	0L,0H,1L,1H	50-51
		20408-S7 Bolt (hex-hd)-3/8"-16 x 1-1/8"- generator to gen. support	1	0L,0H,1L,1H	50-51
		34827-S2 Lockwasher-3/8"-generator to generator support	1	0L,0H,1L,1H	50-51
		44726-S8 Washer (flat)-3/8"-generator to generator support	1	0L,0H,1L,1H	50-51
		44738-S8 Washer (flat)-9/16"-generator bracket to intake manifold	1	1L,1H	51
		356369-S Washer (flat)-11/16" x 2"-shaft to generator front bearing	1	9L,9H,0L,0H,1L,1H	49-51

PL-558

# Lincoln and Lincoln Cosmopolitan

## CHASSIS PARTS CATALOGUE

PART NUMBER	PART NAME	NO. REQ'D	MODEL	YEAR 19__
<b>Generator—Continued</b>				
8BA-10130-A	Pulley (generator)-3.12" diameter-used with 8EL-10002-A or B gen.	1	9L,9H,OL,OH	49-50
8BA-10130-E	Pulley (generator)-3-1/8" diameter-use with 8BA-10002-C generator	1	9L,9H,OL,OH,LL,LH	49-51
8BA-10130-F	Pulley (generator)-2.84" diameter-used with 8EL-10002-A or B and OM-10002 generator	1	9L,9H,OL,OH,LL,LH	49-51
74175-S	Key (woodruff)-No. 6	1	9L,9H,OL,OH,LL,LH	49-51
351496-S	Lockwasher-43/64"-pulley to armature shaft	1	9L,9H,OL,OH,LL,LH	49-51
351124-S	Nut (hex)-21/32"-20-pulley to armature shaft	1	9L,9H,OL,OH,LL,LH	49-51
7EH-10151-C	Support assy (generator)-used with 8EL-10002-A or B and OM-10002 generator	1	9L,9H,OL,OH,LL,LH	49-51
7EH-10151-D	Support assy (generator)-used with 8EL-10002-A or B and OM-10002	1	9L,9H,OL,OH,LL,LH	49-51
8EL-10151-A	Support assy (generator)-used with 8BA-10002-C generator	1	9L,9H,OL,OH,LL,LH	49-51
24389-S8	Bolt (hex-hd)-3/8"-24 x 1"-support to generator	4	9L,9H,OL,OH,LL,LH	49-51
34807-S2	Lockwasher-3/8"-support to generator	4	9L,9H,OL,OH,LL,LH	49-51
34810-S7	Lockwasher-9/16"-gen. support to valve chamber cover	1	9L,9H,OL,OH,LL,LH	49-51
34905-S7	Lockwasher (internal tooth)-1/4"-generator support band	1	9L,9H,OL,OH,LL,LH	49-51
33848-S7	Nut (hex)-9/16"-18-gen. support to valve chamber cover	1	9L,9H,OL,OH,LL,LH	49-51
355301-S2	Screw (socket head cap)-1/4"-20 x 3/4"-generator support band	1	9L,9H,OL,OH,LL,LH	49-51
352740-S7	Stud-9/16"-18 and 9/16"-12 x 2-39/64"-generator support to valve chamber cover	1	9L,9H,OL,OH,LL,LH	49-51

# Lincoln and Lincoln Cosmopolitan

## CHASSIS PARTS CATALOGUE

### Generator—Continued

#### GENERATOR CHART

PART NUMBER	CLAS S	PART NAME	GENERATOR											
			8EL-10002-A	8EL-10002-B	8BA-10002-C	OM-10002								
			NUMBER REQUIRED											
8BA 10005-C		Armature assy (generator)			1									
8EH 10005		Armature assy (generator)	1	1										
8HJ 10005		Armature assy (generator)				1								
8BA 10037-C		Connector assy (generator brush)			1									
01A 10043		Kit (generator brush)-consists of the following (2)01A-10069 Brush assy	1	1	1	1								
68 10044		Screw (generator pole piece)-7/16"-14 x 21/32"	2	2		2								
68 10044		Screw (starter pole piece)-7/16"-14 x 21/32"	Refer to Basic Number 11002											
99B 10044		Screw (generator pole piece)-7/16"-14 x 1-7/64"			4									
8BA 10048-B		Insulator (generator brush holder rivet)	1	1	2	1								
8BA 10048-B		Insulator (starter brush holder rivet)	Refer to Basic Number 11002											
01A 10050		Plate and brush assy (generator rear end)	1	1		1								
		18-11069 Rivet (generator brush end plate)-13/32" x 1/8"	2	2		2								
8BA 10050		Plate and brush assy (generator rear end)			1									
		34804-S8 Lockwasher-No. 12-gen. rear end plate			4									
		31079-S7 Screw (fillister hd)-No. 12-24 x 5/8"			4									
		350189-S8 Screw (fillister hd)-1/4"-28 x 3/8"-plate to brush holder	1	1	2	1								
91A 10057		Spring (generator brush)	2	2	4	2								
01A 10069		Brush assy (generator)-.86" x 1" x .29"-two wire type	2	2	4	2								
		34805-S8 Lockwasher-1/4"-gen. brush to holder	2	2	4	2								
		31598-S Screw (fillister hd)-1/4"-28 x 3/8"-gen. brush to holder	2	2	4	2								
18 10088		Rivet (gen. frame locating)-1/8" x 5/32"	2	2	2	2								
18 10088		Rivet (starter motor frame locating)-1/8" x 5/32"	Refer to Basic Number 11002											





# Lincoln and Lincoln Cosmopolitan

## CHASSIS PARTS CATALOGUE

### Cutout and Voltage Regulator

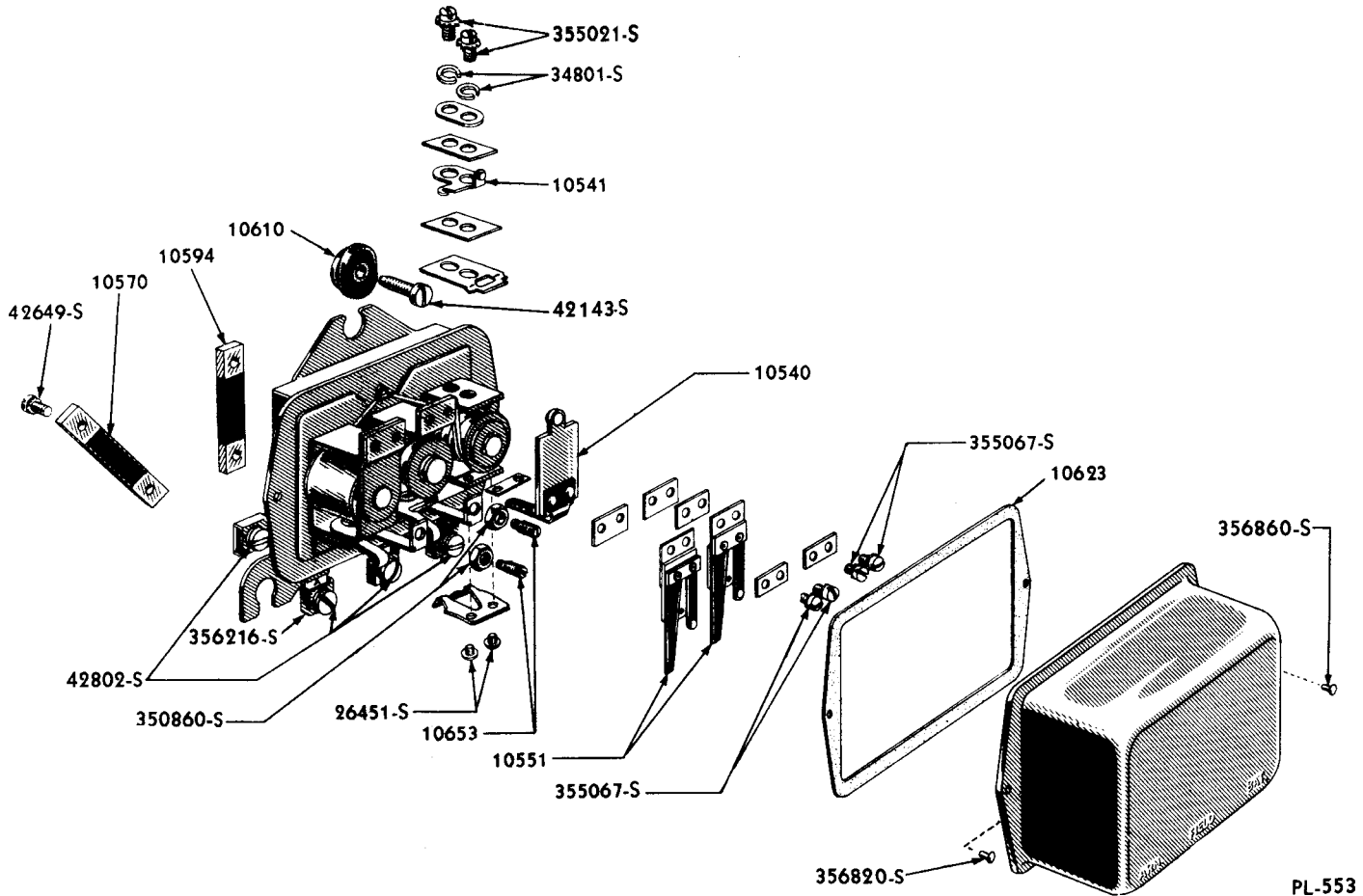

PL-553

### VOLTAGE REGULATOR (5EH-10505-C)

Basic numbers only shown on illustration. Order by Part Numbers shown in list of parts.

PART NUMBER	QUANTITY	PART NAME	NO. REQ'D	MODEL	YEAR 19__
5EH 10505-C		Regulator assy (generator)-40-42 amps.-two piece base-use with 8EL-10002-A	1	9L,9H,OL,OH	49-50
8A 10505-A		Regulator assy (generator)-32 amps-use with OM-10002	1	OL,OH,LL,1H	50-51
8L 10505		Regulator assy (generator)-40-42 amps.-one piece base-use with 8EL-10002-A or B	1	9L,9H,OL,OH,LL,1H	49-51
8BA 10505-A		Regulator assy (generator)-60-62 amps.-use with 8BA-10002-C	1	9L,9H,OL,OH,LL,1H	49-51
FAD 10505-A		Regulator assy (generator)-40 amps.-use with 8EL-10002-A or B	1	9L,9H,OL,OH,LL,1H	49-51
		24406-S8 Bolt (hex-hd)-5/16"-18 x 1-1/8"-regulator mounting	4	9L,9H,OL,OH,LL,1H	49-51
		33797-S7 Nut (hex)-5/16"-18-regulator to mounting spacer	4	9L,9H,OL,OH,LL,1H	49-51
		356216-S7 Retainer (terminal)	4	9L,9H,OL,OH,LL,1H	49-51
		34079-S7 Nut (hex)-No. 10-32-regulator base to limiter cores	3	9L,9H,OL,OH,LL,1H	49-51
		42143-S8 Screw (hex washer head)-No. 14-14 x 3/4"-regulator to-LH-fender apron	3	9L,9H,OL,OH,LL,1H	49-51

# Lincoln and Lincoln Cosmopolitan

## CHASSIS PARTS CATALOGUE

### Cutout and Voltage Regulator—Continued

#### CUTOUT AND VOLTAGE REGULATOR CHART

PART NUMBER	CLASS	PART NAME	CUTOUT AND VOLTAGE REGULATOR																	
			5EH-10505-C	8A-10505-A	8L-10505		8BA-10505-A		FAD-10505-A											
			NUMBER REQUIRED																	
19B 10522		Insulator (current limiter contact post)						2												
19B 10522		Insulator (voltage limiter contact post)						2												
19B 10523-C		Screw (current limiter armature adjusting)- No. 10-32 x 5/8"						1												
19B 10523-C		Screw (voltage limiter armature adjusting)- lower-No. 10-32 x 5/8"						1												
19B 10523-C		Screw (cutout magnet frame)-No. 10-32 x 5/8"						1												
19B 10523-D		Screw (current limiter armature adjusting)- upper-No. 10-32 x 11/16"						1												
19B 10523-D		Screw (voltage limiter armature adjusting)- upper-No. 10-32 x 11/16"						1												
		350860-S Nut (hex check)-No. 10- 32						5												
19B 10524		Insulator (current limiter unit contact post)						2												
19B 10524		Insulator (voltage limiter frame)						2												
19B 10535		Point (cutout unit main contact)						1												
81A 10540-B		Armature assy (cutout)	1																	
8A 10540		Armature assy (cutout)		1	1								1							
		26451-S7 Screw (rd-hd)-No. 6-32 x 3/16"-cutout armature spring to cutout frame	2		2															
19B 10540-C		Armature assy (cutout unit)											1							
01A 10541-B		Point and post assy (cutout contact)	1																	
8A 10541		Point and post assy (cutout contact)		1	1										1					
		355021-S7 Screw and lockwasher assy (binding head)- No. 6-32 x 21/64"	2	2	2															
01A 10551-A		Armature assy (current limiter)-Steel hinge	1																	
01A 10551-A		Armature assy (regulator unit)-Steel hinge	1																	
01A 10551-B		Armature assy (regulator unit)-Bimetal hinge	1																	
11AS 10551		Armature assy (voltage limiter)											1							
19B 10551-B		Armature assy (regulator unit)											1							
51A 10551		Armature assy (regulator)	1																	
8A 10551		Armature assy (regulator)		1	1										1					
		355022-S7 Screw and lockwasher assy (binding head)- No. 6-32 x 5/16"- armature assy to post											4							
		355067-S7 Screw and lockwasher assy (fillister head)- No. 8-32 x 5/16"-reg. armature to regulator	4	4	4										4					
19B 10560-A		Cover (generator regulator)											1							
		8H-10666 Bracket (voltage reg. mtg.)	1		1								1							





# Lincoln and Lincoln Cosmopolitan

## CHASSIS PARTS CATALOGUE

### Battery

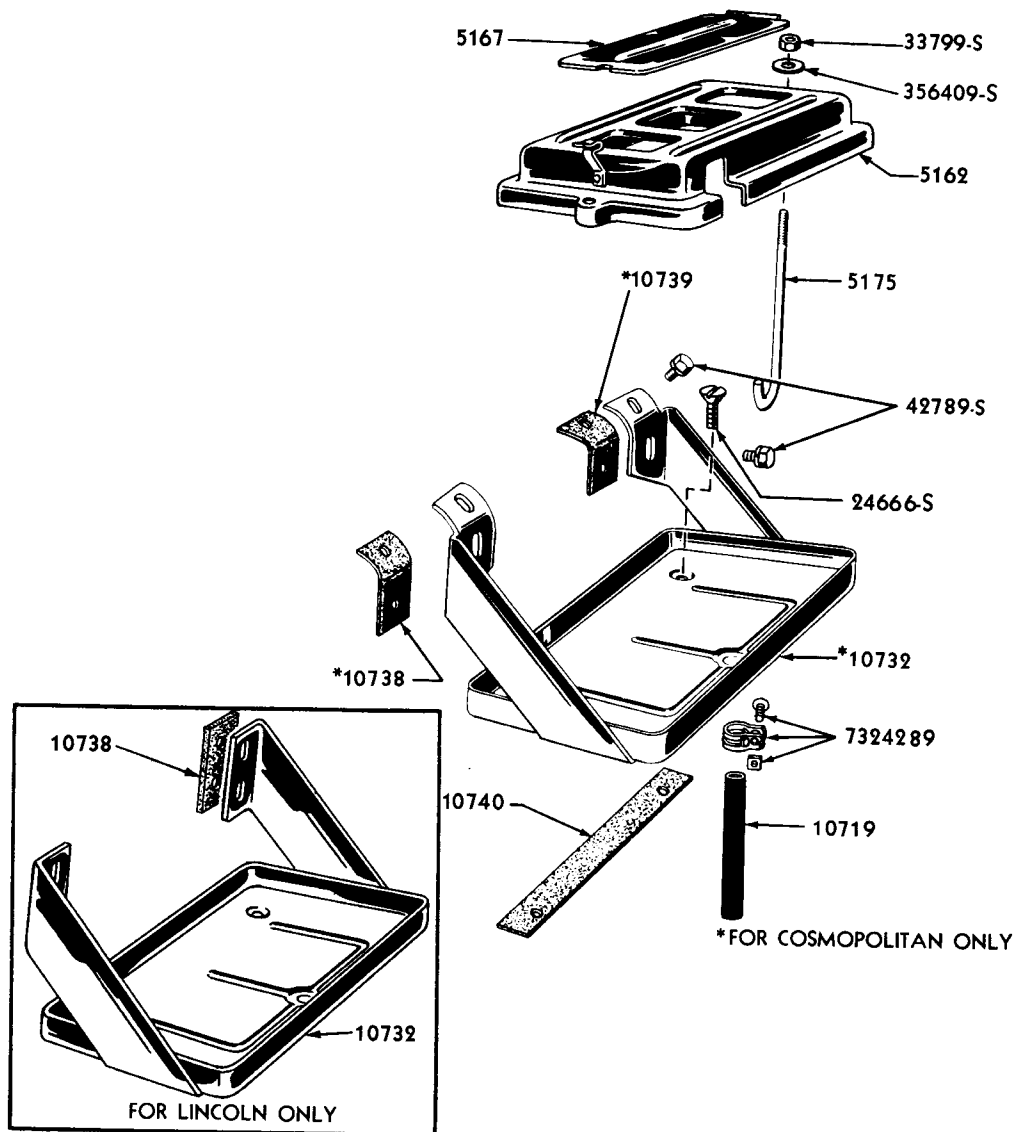

PL-642

### BATTERY TRAY AND RELATED PARTS

Basic numbers only shown on illustration. Order by Part Numbers shown in list of parts.

PART NUMBER	NO. REQ'D	PART NAME	MODEL	YEAR
0L-5162-B	1	Cover assy (battery box)	0L, 0H, 1L, 1H	19 50-51
51A-5165-B	1	Clamp assy (battery)	9L, 9H	49
0L-5167-B	1	Lid (battery cover inspection)	0L, 0H, 1L, 1H	50-51
7EH-5175	2	Bolt (battery clamp)	9L, 9H, 0L, 0H, 1L, 1H	49-51
33799-S7	2	Nut (hex)-3/8"-16-bolt to clamp	9L, 9H, 0L, 0H, 1L, 1H	49-51
356409-S8	2	Washer (flat)-3/8"-bolt to clamp	9L, 9H, 0L, 0H, 1L, 1H	49-51

# Lincoln and Lincoln Cosmopolitan

## CHASSIS PARTS CATALOGUE

PART NUMBER	PART NAME	NO. REQ'D	MODEL	YEAR 19
<b>Battery—Continued</b>				
06H 10655-A	Battery assy-51 plate-6 volt-120 amp. hour-10-5/8" x 7-5/16" x 8-5/16"	1	9L,9H,OL,OH,LL,1H	49-51
01A 10664	Washer (non-flooding cover)-Rubber	3	9L,9H,OL,OH,LL,1H	49-51
8H 10666	Bracket (voltage regulator mounting)	1	9H,OH,1H	49-51
8L 10719-A	Hose (battery tray drain)	1	9L,9H,OL,OH,LL,1H	49-51
	06H-16377 Spring (battery drain hose to frame)	1	9L,9H,OL,OH,LL,1H	49-51
	26H-7324289 Clamp assy (battery drain hose to tray)	1	9L,9H,OL,OH,LL,1H	49-51
01A 10720	Plug (battery filler)	3	9L,9H,OL,OH,LL,1H	49-51
8H 10732	Tray and support assy (battery)	1	9H,OH,1H	49-51
8L 10732	Tray and support assy (battery)	1	9L,OL,LL	49-51
	42789-S7 Bolt & lockwasher assy (hex-hd) -5/16"-18 x 3/4"-battery tray and support to splash pan	4	9L,9H,OL,OH,LL,1H	49-51
	24666-S7 Screw (flat head)-5/16"-18 x 3/4"-tray and support to brkt.	2	9L,9H,OL,OH,LL,1H	49-51
8H 10738	Anti squeak (battery support bracket to fender apron)-front	1	9H,OH,1H	49-51
8L 10738	Anti squeak (battery support bracket to fender apron)-front	2	9L,OL,LL	49-51
8H 10739	Anti squeak (battery support bracket to fender apron)-rear	1	9H,OH,1H	49-51
8H 10740	Anti squeak (battery tray to support)	1	9L,9H,OL,OH,LL,1H	49-51

## Instrument Panel Indicators

	8L-9271 Cluster assy (instrument)-less instruments	1	9L,9H	49
	8L-9272-A Bar (instrument cluster bus)-3-1/32" overall length	1	9L,9H	49
	8L-9272-B Bar (instrument cluster bus)-2-1/64" overall length	1	9L,9H	49
	21A-9272 Bar (instrument cluster bus)-1-17/32" overall length	1	OL,OH,LL,1H	50-51
	8L-9273 Indicator assy (oil pressure)	1	9L,9H	49
	OL-9273 Indicator assy (oil pressure)	1	OL,OH,LL,1H	50-51
	8L-9280 Indicator assy (fuel level)	1	9L,9H	49
	OL-9280 Indicator assy (fuel level)	1	OL,OH,LL,1H	50-51
OL 10841-AB	Housing (instrument and control cluster)-replaced by (1) 1L-10841-AA, (1) OL-18475-B, (1) 1L-18498, (1) OM-18561-B and (1) OM-18646	1	OL,OH	50
1L 10841-AA	Housing (instrument and control cluster)	1	1L,1H	51

# Lincoln and Lincoln Cosmopolitan

## CHASSIS PARTS CATALOGUE

### Instrument Panel Indicators—Continued

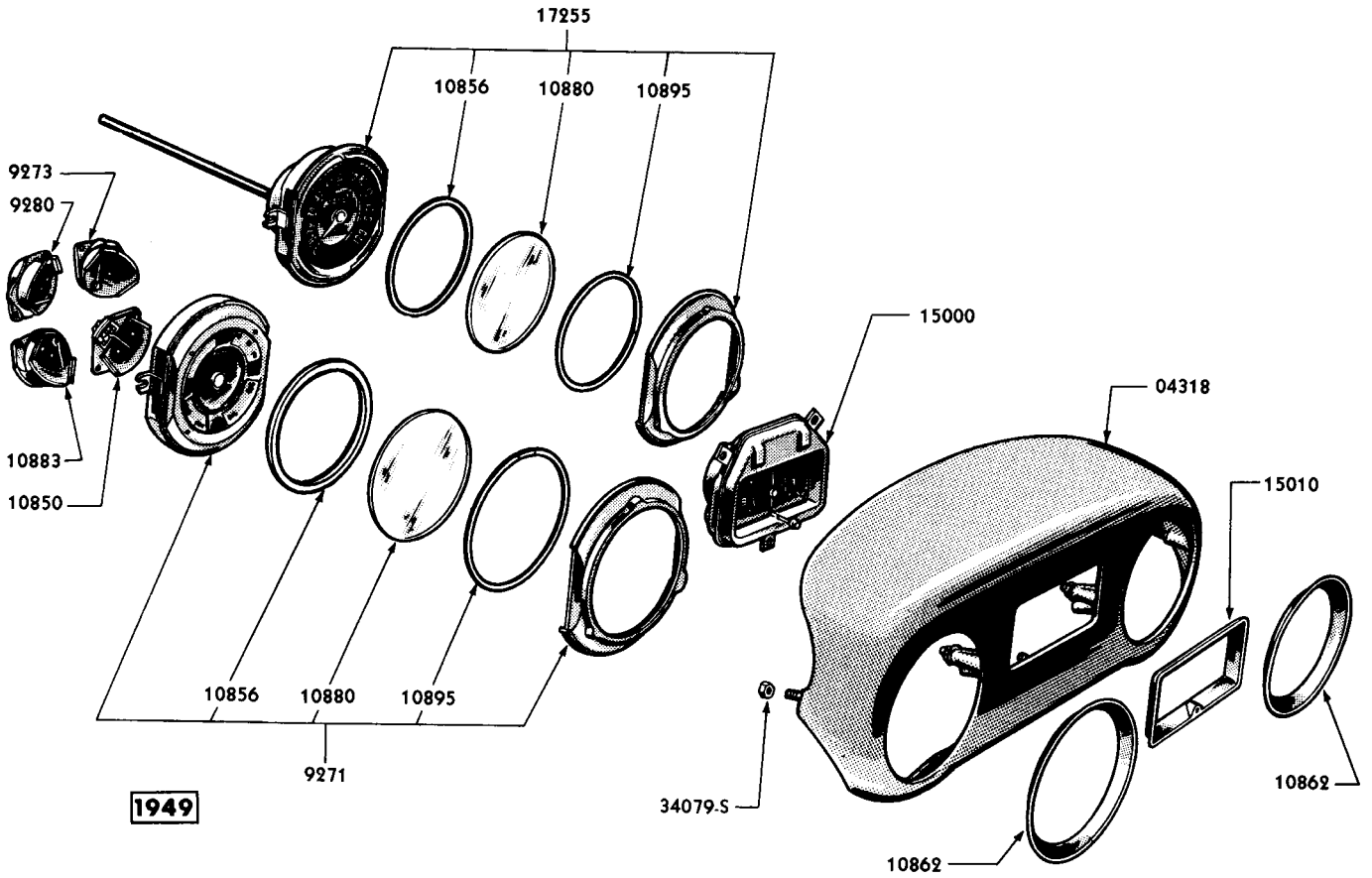

PL-311

### INSTRUMENT CLUSTER ASSY AND RELATED PARTS

Basic numbers only shown on illustration. Order by Part Numbers shown in list of parts.

PART NUMBER	QUANTITY	PART NAME	NO. REQ'D	MODEL	YEAR 19
OL 10842		Plate assy (instrument cluster back)-complete	1	OL,OH,LL,LH	50-51
		41294-S8 Screw (fillister head self tapping)-No. '8-32 x 3/8"	15	OL,OH,LL,LH	50-51
		41036-S8 Screw (hex-head)-No. 10-32 x 3/8"-plate to radio mounting bracket and control housing	4	OL,OH,LL,LH	50-51
		41178-S8 Screw (hex-head)-No. 10-24 x 1/2"-plate to instrument panel	3	OL,OH,LL,LH	50-51
		41181-S8 Screw (hex-head)-No. 10-20 x 1/2"-plate to instrument panel	8	OL,OH,LL,LH	50-51
		41220-S8 Screw (hex-head)-1/4"-20 x 7/8"-plate to instrument panel	1	OL,OH,LL,LH	50-51
		44713-S8 Washer (flat)-No. 10-cluster plate to instrument panel	3	OL,OH,LL,LH	50-51
		44719-S8 Washer (flat)-1/4"-plate to instrument panel	9	OL,OH,LL,LH	50-51

*Lincoln and Lincoln Continental*  
CHASSIS PARTS CATALOGUE

Instrument Panel Indicators—Continued

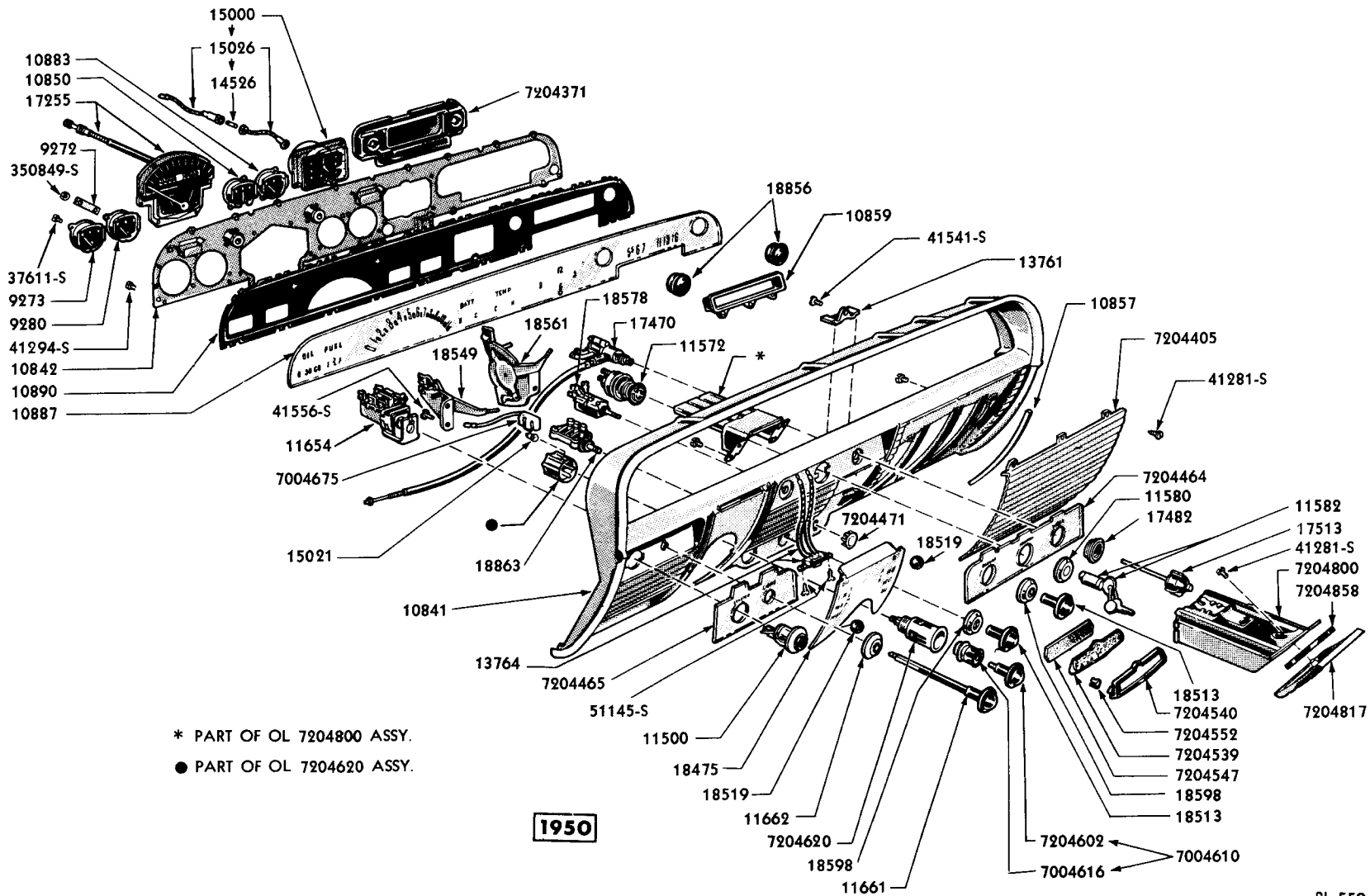

PL-559

**INSTRUMENT CLUSTER ASSY AND RELATED PARTS**

Basic numbers only shown on illustration. Order by Part Numbers shown in list of parts.

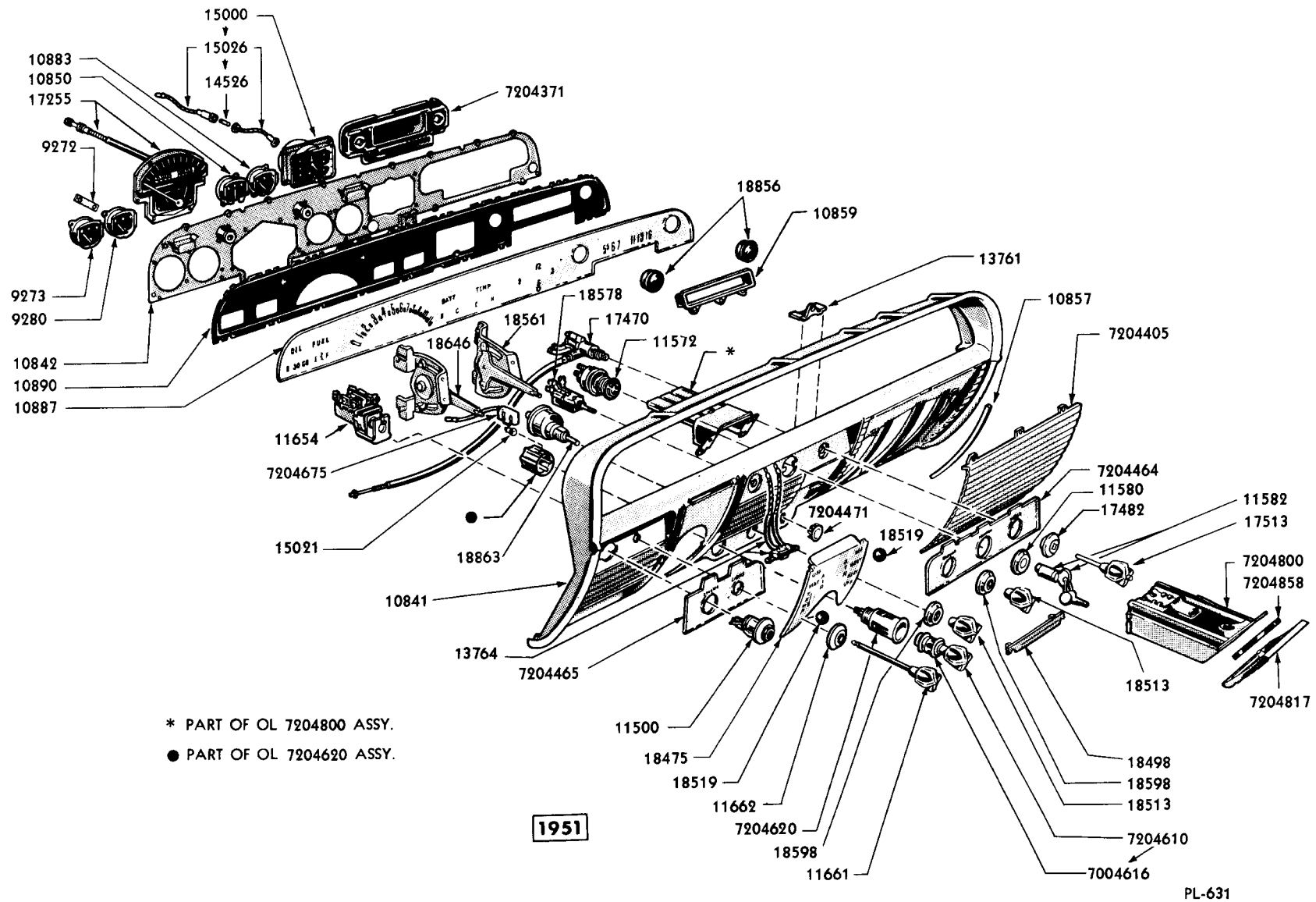

**INSTRUMENT CLUSTER ASSY AND RELATED PARTS**

Basic numbers only shown on illustration. Order by Part Numbers shown in list of parts.

# Lincoln and Lincoln Cosmopolitan

## CHASSIS PARTS CATALOGUE

PART NUMBER	QTY	PART NAME	NO. REQ'D	MODEL	YEAR 19
		44724-S8 Washer (flat)-5/16"-spacer to instrument panel	2	1L,1H	51
		OL-13584 Jewel and housing assy (instrument cluster signal lamp)	2	OL,OH,1L,1H	50-51
	NS	OL-13589 Baffle (instrument cluster signal lamp)-3/4" I.D. x 55/64" wide-Paper-secure locally	1	OL,OH,1L,1H	50-51
8L 10850-C		Indicator assy (charge)	1	9L,9H	49
OL 10850		Indicator assy (charge)	1	OL,OH,1L,1H	50-51
		37611-S7 Screw (fillister head pointed)-No. 8-32 x 1/4"	2	9L,9H,OL,OH,1L,1H	49-51
8L 10856		Gasket (instrument cluster)-inner	2	9L,9H	49
OL 10857	NS	Anti squeak (instrument cluster radio grille)-secure locally	3	OL,OH,1L,1H	50-51
OL 10859		Bezel (instrument cluster radio push button)	1	OL,OH,1L,1H	50-51
		41281-S8 Screw (fillister head)-No. 8-32 x 1/4" bezel to control housing	3	OL,OH,1L,1H	50-51
8L 10862		Bezel (speedometer and instrument cluster)	2	9L,9H	49
OL 10863	NS	Baffle (instrument cluster dust)-Paper-secure locally	1	OL,OH,1L,1H	50-51
1H 10872-A		Moulding (control panel steering column)	1	1H	51
8L 10880		Glass (instrument cluster)	2	9L,9H	49
91A 10882		Clip (cigar lighter wiring to front seat frame)	7	9L72-76,9H72-76	49
8L 10883		Indicator assy (temperature)	1	9L,9H	49
OL 10883		Indicator assy (temperature)	1	OL,OH,1L,1H	50-51
		37611-S7 Screw (fillister head pointed)-No. 8-32 x 1/4"	2	9L,9H,OL,OH,1L,1H	49-51
8A 10884		Bulb assy (electric heat indicator)-use in L.H. head	1	9L,9H,OL,OH	49-50
99A 10884		Bulb assy (electric heat indicator)-LH cylinder head	1	OL,OH,1L,1H	50-51
		355098-S7 Screw and lockwasher assy-(rd-hd)-No. 8-32 x 1/4"-wiring to heat indicator bulb	1	9L,9H,OL,OH,1L,1H	49-51
OL 10887-C		Dial (instrument cluster main)	1	OL,OH,1L,1H	50-51
OL 10890		Mask (instrument cluster)	1	OL,OH,1L,1H	50-51
8L 10895		Gasket (instrument cluster)-outer	2	9L,9H	49
01A 10990		Blub assy (engine excessive heat indicator)-RH cylinder head	1	OL,OH,1L,1H	50-51
8A 10990		Bulb assy (engine excessive heat indicator)-use in R.H. head	1	9L,9H,OL,OH	49-50
		34802-S7 Lockwasher-No. 8-wiring to excessive heat indicator assy	2	9L,9H,OL,OH,1L,1H	49-51
		27687-S Screw (rd-hd)-No. 8-32 x 3/16"-wiring to excessive heat indicator	2	9L,9H,OL,OH,1L,1H	49-51

# Lincoln and Lincoln Cosmopolitan

## CHASSIS PARTS CATALOGUE

### Starter

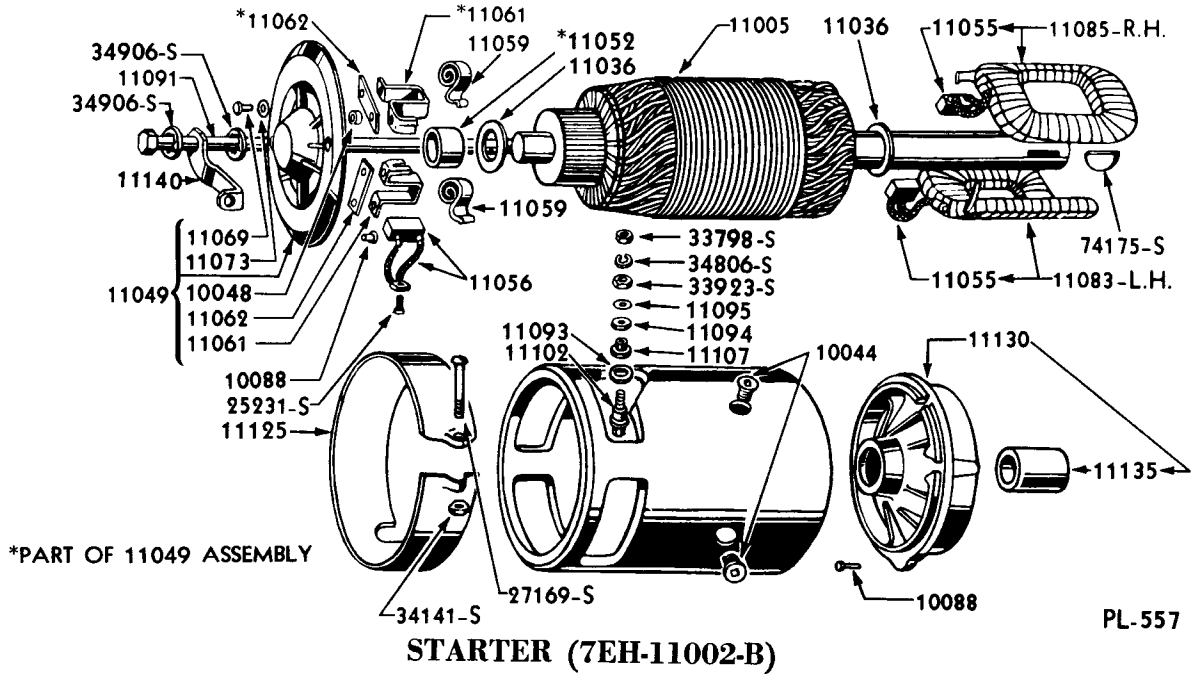

Basic numbers only shown on illustration. Order by Part Numbers shown in list of parts.

PART NUMBER	CLASS	PART NAME	NO. REQ'D	MODEL	YEAR
7EH 11002-B		Starter assy	1	9L,9H,0L,0H,1L,1H	49-51
8EL 11002-B		Starter assy-less drive assy and drive pin	1	9L,9H,0L,0H,1L,1H	49-51
		8H-14431 Cable assy (relay to starter)-52" long	1	9L,9H,0H,1H	49-51
		0L-14431 Cable assy (relay to starter)-18-1/2" long	1	0L,0H,1L	50-51

### STARTER CHART

PART NUMBER	CLASS	PART NAME	STARTER												
			7EH-11002-B												
18 11005		Armature assy (starter)	1												
52 11005		Armature assy (starter)									1				
18 11036		Washer (starter armature thrust)-21/32" I.D. x 1-1/8" O.D.	2								2				
18 11049		Plate, bushing and brush holder assy (starter brush end)	1								1				
		68-10044 Screw (starter pole piece) -7/16"-14	4								4				

++ Not used with HYDRA-MATIC transmission  
 + Used with HYDRA-MATIC transmission



# Lincoln and Lincoln Cosmopolitan

## CHASSIS PARTS CATALOGUE

### Starter—Continued

#### STARTER CHART—CONTINUED

PART NUMBER	CLASS	PART NAME	STARTER											
			+7EH-11002-B					+8EL-11002-B						
				NUMBER REQUIRED										
		8BA-10048-B Insulator (starter brush holder rivet)	4					4						
		18-10088 Rivet (starter frame locating)-1/8" x 5/32"	2					2						
18 11052		Bearing (starter brush end plate)-5/8" I.D. x 3/4" O.D. x 9/16" wide	1					1						
18 11055	NS	Brush assy (starter)-serviced in Kit 18-11057	2					2						
18 11056	NS	Brush assy (starter ground)-serviced in Kit 18-11057	2					2						
		25231-S7 Screw (flat head)-No. 10-32 x 1/2"-starter brush attaching	2					2						
18 11057		Kit (starter brush)-consists of the following (2) 18-11055 Brush (2) 18-11056 Brush	1					1						
B 11059		Spring (starter brush)	4					4						
18 11061		Holder (starter brush)	4					4						
B 11062		Insulation (starter brush holder)	2					2						
18 11069		Rivet (starter brush end plate)-13/32" long x 1/8" diameter	8					8						
18 11069		Rivet (generator brush end plate)-13/32" x 1/8"	Refer to Basic Number 10050											
18 11083		Coil assy (starter field)-left	1					1						
18 11085		Coil assy (starter field)-right	1					1						
7EH 11091		Bolt (hex head starter thru)-5/16"-18 x 7-49/64"	2					2						
		34906-S8 Lockwasher-5/16"	2					2						
7RA 11093		Washer (starter field terminal)-45/64" O.D.	1					1						
18 11094-B		Washer (starter field terminal insulator)-21/64" I.D. x 25/32" O.D.	1					1						
7RA 11095		Washer (starter field terminal)-flat	1					1						
18 11102-B		Terminal (starter field)	1					1						
		34806-S7 Lockwasher-5/16"	1					1						
		33798-S8 Nut (hex)-5/16"-24	1					1						
		33923-S7 Nut (hex check)-5/16"-24	1					1						

++ Not used with HYDRA-MATIC transmission

+ Used with HYDRA-MATIC transmission

# Lincoln and Lincoln Cosmopolitan

## CHASSIS PARTS CATALOGUE

### Starter—Continued

#### STARTER CHART—CONTINUED

PART NUMBER	CLASS	PART NAME	STARTER										
			††7EH-11002-B				†8EL-11002-B						
			NUMBER REQUIRED										
18 11107-B		Insulator (starter terminal)	1				1						
8EL 11125-A		Band assy (starter cover)	1										
8EL 11125-B		Band assy (starter cover)					1						
		34141-S8 Nut (square)-No. 10-32	1				1						
		63527-3 Rivet (oval head)-1/8" x 3/16"-gasket to band	1				4						
		27177-S7 Screw (rd.-hd)-No. 10-32 x 1-1/2"	1				1						
		8EL-6436 Seal (starter motor to dust cover)-Rubber	1				1						
7EH 11130		Plate assy (starter rear end)	1										
8EQ 11130-B		Plate assy (starter rear end)					1						
B 11135		Bushing (starter rear end plate)-5/8" I.D. x 3/4" O.D. x 1-5/32"	1										
19B 11135		Bushing (starter rear end plate)					1						
7EH 11140		Bracket (starter to oil pan)	1										
8EL 11140		Bracket (starter to oil pan)					1						

### Starter Drive

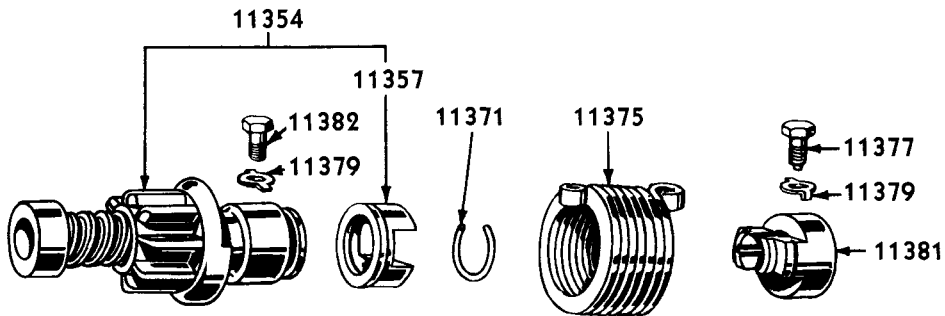

PM-459

#### STARTER DRIVE (B-11350)

Basic numbers only shown on illustration. Order by Part Numbers shown in list of parts.

- †† Not used with HYDRA-MATIC transmission
- † Used with HYDRA-MATIC transmission

# Lincoln and Lincoln Cosmopolitan

## CHASSIS PARTS CATALOGUE

PART NUMBER	PART NAME	NO. REQ'D	MODEL	YEAR
<b>Starter Drive—Continued</b>				
++B 11350	Drive assy (starter)	1	9L, 9H, 0L, 0H, 1L, 1H	49-51
+29B 11350	Drive assy (starter)	1	9L, 9H, 0L, 0H, 1L, 1H	49-51
	74175-S Key (woodruff)-No. 6-starter drive assy retaining	1	9L, 9H, 0L, 0H, 1L, 1H	49-51

### STARTER DRIVE CHART

PART NUMBER	CLASS	PART NAME	STARTER DRIVE																	
			++B-11350		+29B-11350															
			NUMBER REQUIRED																	
B 11354		Screw, shaft & pinion assy (starter drive)	1																	
B 11357-A		Sleeve (starter drive screw shaft)	1																	
52 11365-B		Pin (starter drive pinion)			1															
29B 11366		Shaft assy (starter)			1															
09B 11367		Pinion and barrel assy (starter drive)			1															
52 11368		Spring (starter drive meshing)			1															
52 11369		Spring (starter drive anti drift)			1															
52 11370		Snap ring (starter drive pinion and barrel)			1															
B 11371		Ring (starter screw shaft and sleeve take up)	1																	
52 11372		Plate (starter drive spring anchor)			2															
B 11375		Spring (starter drive)	1																	
29B 11375		Spring (starter drive)			1															
B 11377		Screw (starter drive head spring)	1																	
B 11379		Washer (starter drive shaft spring screw lock)	2																	
B 11381-B		Head (starter drive)	1																	
B 11382		Screw (starter drive shaft spring)	1																	

PART NUMBER	PART NAME	NO. REQ'D	MODEL	YEAR
-------------	-----------	-----------	-------	------

### Starter Switch

21A 11450	Relay assy (starter motor)	1	9L, 9H, 0L, 0H, 1L, 1H	49-51
	31527-S7 Screw (hex washer head)-No. 14-14 x 1/2"-relay to apron	2	9L, 9H, 0L, 0H, 1L, 1H	49-51
6H 11500	Switch assy (starter push button)-Chrome button	1	9L, 9H	49
0L 11500	Switch assy (starter push button)-Black Plastic button	1	0L, 0H, 1L, 1H	50-51

++ Not used with HYDRA-MATIC transmission

+ Used with HYDRA-MATIC transmission

# Lincoln and Lincoln Cosmopolitan

## CHASSIS PARTS CATALOGUE

PART NUMBER	PART NAME	NO. REQ'D	MODEL	YEAR
<b>Ignition Switch</b>				
6A 11572-B	Switch assy (ignition)	1	9L,9H	49
OL 11572-A	Switch assy (ignition)	1	OL,OH,1L,1H	50-51
	34803-S7 Lockwasher-No. 10	3	9L,9H,OL,OH,1L,1H	49-51
	34079-S7 Nut (hex)-No. 10-32-wiring to ignition switch	3	9L,9H,OL,OH,1L,1H	49-51
8L 11580	Bezel assy (ignition switch)-1-31/64" O.D.	1	9L,9H	49
OL 11580	Bezel assy (ignition switch)-1-3/64" O.D.	1	OL,OH,1L,1H	50-51
6A 11581-B	Spring (ignition switch retaining)-used with 6A-11572-B	1	9L,9H	49
OL 11581	Spring (ignition switch retaining)-used with OL-11572-A	1	OL,OH,1L,1H	50-51
8H 11582-A	Cylinder and keys assy (ignition switch lock)	1	9L,9H,OL,OH	49-50
8H 11582-B	Cylinder and keys assy (ignition switch lock)	1	9L,9H,OL,OH,1L,1H	49-51

## Lighting Switch

8L 11653	Wiring assy (headlamp, foglamp, parking lamp and horn lead)	1	9L,9H,OL,OH	49-50
7RA 11654	Switch assy (headlamp control hand)	1	9L,9H	49
OL 11654	Switch assy (lighting control hand)	1	OL,OH,1L,1H	50-51
	26457-S7 Screw (rd-hd)-No. 8-32 x 1/4"-wiring to headlamp control switch	6	9L,9H,OL,OH,1L,1H	49-51
OL 11661	Knob and insert assy (headlamp control switch)-with globular knob	1	OL,OH	50
1L 11661	Knob and insert assy (headlamp control switch)-with four fin knob	1	1L,1H	51
OL 11662	Bezel (headlamp control switch)	1	OL,OH,1L,1H	50-51

## Ignition Coil

8BA 12029	Coil assy (ignition)-6 volt	1	9L,9H,OL,OH,1L,1H	49-51
	350267-S7 Bolt & lockwasher assy-5/16"-24 x 5/8"-ignition coil to dash	2	9H,OH,1H	49-51
	34803-S7 Lockwasher-No. 10-ignition to coil primary wire	1	9L,9H,OL,OH,1L,1H	49-51
	34079-S7 Nut (hex)-No. 10-32-ignition to coil primary wire	1	9L,9H,OL,OH,1L,1H	49-51
	31493-S8 Screw (hex-hd self tapping)-No. 14-10 x 5/8"-ignition coil to dash	2	9L,OL,1L	49-51
7EH 12043	Strap (ignition coil)	1	9L,9H,OL,OH,1L,1H	49-51
	34079-S7 Nut (hex)-No. 10-32	1	9L,9H,OL,OH,1L,1H	49-51
	34141-S7 Nut (square)-No. 10-32	1	9L,9H,OL,OH,1L,1H	49-51
	27177-S7 Screw (rd-hd)-No. 10-32 x 1-1/2"	1	9L,9H,OL,OH,1L,1H	49-51

# Lincoln and Lincoln Cosmopolitan

## CHASSIS PARTS CATALOGUE

### Distributor, Circuit Breaker and Distributor Wiring

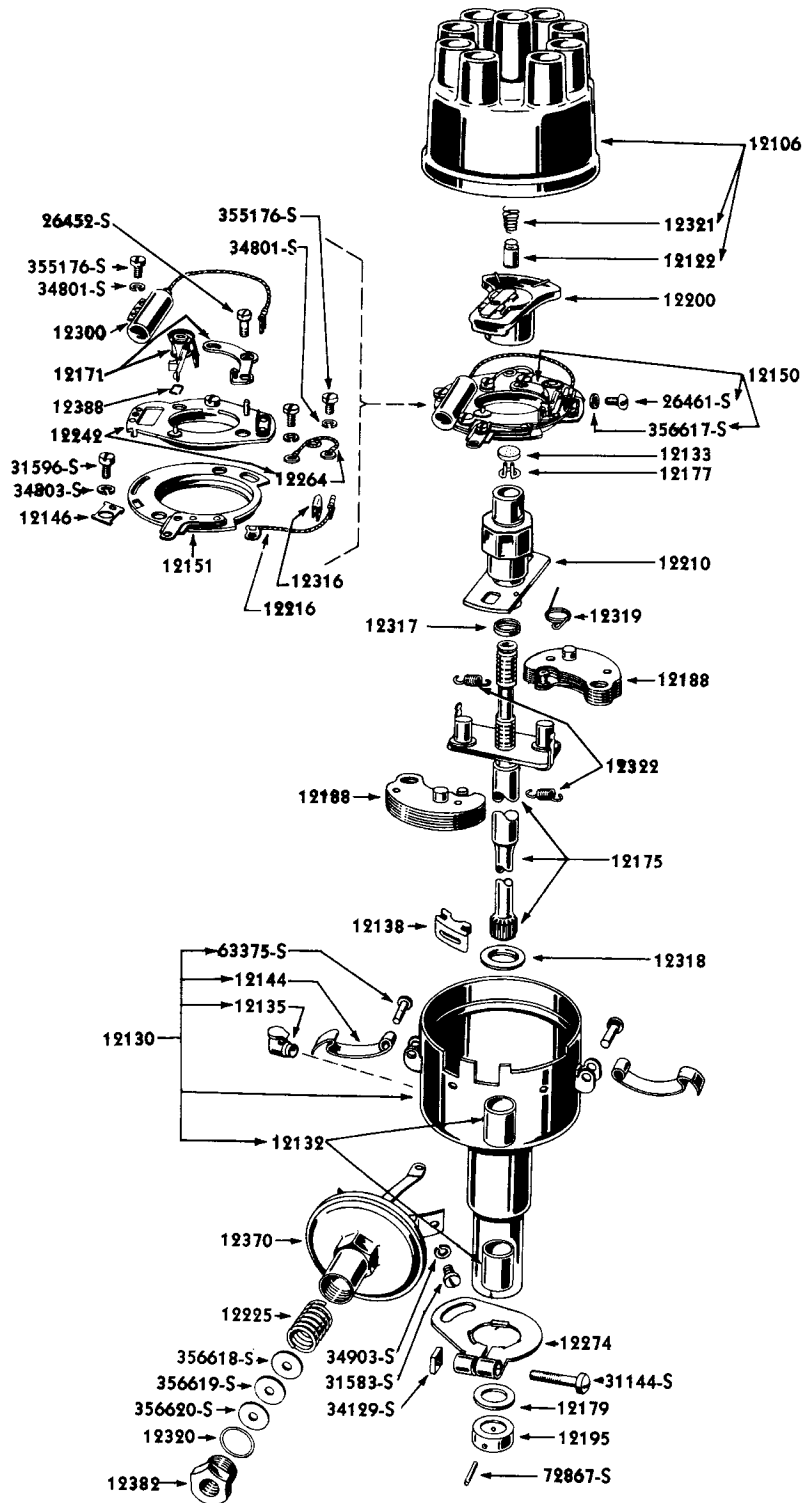

PL-528

### DISTRIBUTOR (8EL)

Basic numbers only shown on illustration. Order by Part Numbers shown in list of parts.

# Lincoln and Lincoln Cosmopolitan

## CHASSIS PARTS CATALOGUE

### Distributor, Circuit Breaker and Distributor Wiring — Continued

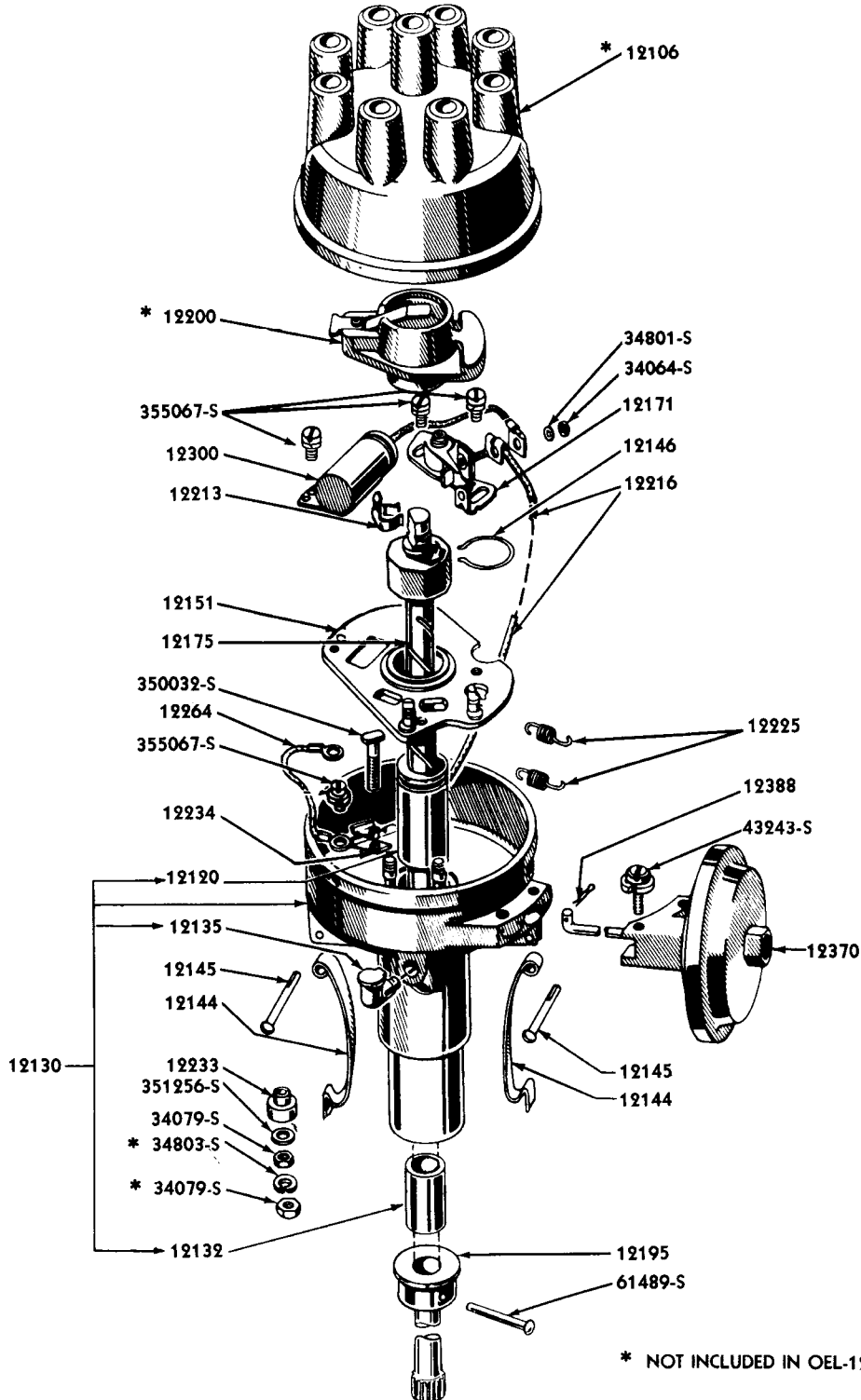

\* NOT INCLUDED IN OEL-12127 ASSEMBLY

PL-643

### DISTRIBUTOR (OEL)

Basic numbers only shown on illustration. Order by Part Numbers shown in list of parts.

# Lincoln and Lincoln Cosmopolitan

## CHASSIS PARTS CATALOGUE

PART NUMBER	PART NAME	NO. REQ'D	MODEL	YEAR 19
<b>Distributor, Circuit Breaker and Distributor Wiring—Continued</b>				
7RA 12106	Housing assy (distributor terminal)-alternate with FAB-12106-A	1	OL,OH,LL,LH	50-51
8EL 12106	Housing assy (distributor terminal)	1	9L,9H	49
FAB 12106-A	Housing assy (distributor terminal)-alternate with 7RA-12106	1	OL,OH,LL,LH	50-51
8EL 12110	Conduit (ignition cable)	1	9L,9H	49
8BA 12111	Bracket (ignition cable mounting)-RH side of engine	1	9L,9H,OL,OH,LL,LH	49-51
7RA 12112-B	Bracket (ignition cable mounting)-LH side of engine	1	9L,9H,OL,OH,LL,LH	49-51
2N 12113	Insulator (distributor to spark plug wire)	8	9L,9H,OL,OH,LL,LH	49-51
2N 12113	Insulator (distributor to coil)	2	9L,9H,OL,OH,LL,LH	49-51
7RA 12120	Bushing (distributor base)-15/32" I.D. x 3/4" O.D. x 1-3/4" long	1	9L,9H,OL,OH,LL,LH	49-51
8EL 12122	Brush (distributor terminal housing)	1	9L,9H	49
8EL 12127	Distributor assy-less terminal housing and rotor	1	9L,9H	49
OEL 12127	Distributor assy-less terminal housing & rotor assy	1	OL,OH,LL,LH	50-51
	350860-S Nut (hex)-No. 10-32	1	OL,OH,LL,LH	50-51
	355407-S8 Screw & lockwasher assy (hex hd)-5/16"-18 x 5/8"-distributor to engine	1	9L,9H,OL,OH,LL,LH	49-51
8EL 12130	Base, bushings, oiler and clamps assy (distributor)	1	9L,9H	49
OEL 12130	Base, bushing, oiler and clamps assy (distributor)	1	OL,OH,LL,LH	50-51
	B-10141 Cup (distributor oil)	1	OL,OH,LL,LH	50-51
7RA 12132	Bushing (distributor)-used with OEL-12130	1	OL,OH,LL,LH	50-51
8EL 12132	Bushing (distributor)-used with 8EL-12130	2	9L,9H	49
8EL 12133	Wick (distributor shaft)	1	9L,9H	49
8EL 12135	Oiler (distributor base)	1	9L,9H	49
8EL 12138	Plug (distributor base)	1	9L,9H	49
7RA 12144	Clamp (distributor terminal housing)	2	OL,OH,LL,LH	50-51
8EL 12144	Clamp (distributor terminal housing)	2	9L,9H	49
	63375-S10 Rivet (oval-hd tubular)-1/8" x 19/32"-terminal housing clamps to base	2	9L,9H	49
B 12145	Rivet (distributor cap clamps)	2	OL,OH,LL,LH	50-51
7RA 12146	Retainer (distributor breaker plate)	1	OL,OH,LL,LH	50-51
8EL 12146	Retainer (distributor breaker plate)	2	9L,9H	49
	34803-S7 Lockwasher-No. 10-retainer to distributor	2	9L,9H,OL,OH,LL,LH	49-51
8EL 12150	Breaker assy (distributor)	1	9L,9H	49
OBA 12150-A NS	Breaker assy (distributor)-service details	1	OL,OH	50
OBA 12150-B NS	Breaker assy (distributor)-service details	1	LL,LH	51
	31596-S7 Screw (fillister-hd)-No. 10-32 x 3/8"-breaker assy to distributor	1	9L,9H	49
8EL 12151	Plate assy (distributor breaker)	1	9L,9H	49
OBA 12151	Plate assy (distributor breaker)	1	OL,OH,LL,LH	50-51
7RA 12171	Point set-consists of the following (1) Breaker arm assy (1) Contact point and bracket assy	1	OL,OH,LL,LH	50-51
	34801-S7 Lockwasher-No. 6-breaker arm and bracket assy to dist.	1	OL,OH,LL,LH	50-51
	34051-S7 Nut (hex)-No. 6-32-breaker arm and bracket assy to dist.	1	OL,OH,LL,LH	50-51

# Lincoln and Lincoln Cosmopolitan

## CHASSIS PARTS CATALOGUE

PART NUMBER	PART NAME	NO. REQ'D	MODEL	YEAR 19
	355067-S7 Screw and lockwasher assy (fillister head)-No. 8-32 x 5/16"-bracket lock	2	OL,OH,LL,1H	50-51
	351192-S Washer (flat)-9/64" x 1/4"- dist. breaker arm to contact bracket	1	OL,OH,LL,1H	50-51
8EL 12171	Point set (distributor)-consists of the following (1) Breaker arm assy (1) Contact point and bracket assy	1	9L,9H	49
	44707-S8 Lockwasher-No. 6-to attach breaker contact seat	1	9L,9H	49
	26452-S7 Screw (rd-hd)-No. 8-32 x 3/16"- breaker set to sub plate	1	9L,9H	49
8EL 12175	Shaft assy (distributor)	1	9L,9H	49
OEL 12175	Shaft assy (distributor)	1	OL,OH,LL,1H	50-51
8EL 12177	Retainer (distributor cam)	1	9L,9H	49
8EL 12179	Washer (distributor shaft thrust)-lower	1	9L,9H	49
8EL 12188	NS Weight assy (distributor)-replaced by 8EL-12322	2	9L,9H	49
7HA 12195	Collar (distributor shaft)	1	OL,OH,LL,1H	50-51
8EL 12195	Collar (distributor shaft)	1	9L,9H	49
	72867-S Pin (straight)-1/8" x 7/8"	1	9L,9H	49
	61489-S Rivet (solid button head)-1/8" x 13/16"	1	OL,OH,LL,1H	50-51
7RA 12200	Rotor assy (distributor)	1	OL,OH,LL,1H	50-51
8EL 12200	Rotor assy (distributor)	1	9L,9H	49
8EL 12210	Cam assy (distributor)	1	9L,9H	49
OBA 12213	Spring (distributor shaft)	1	OL,OH,LL,1H	50-51
	34051-S7 Nut (hex)-No. 6-32-primary assy to breaker arm & brkt. assy	1	OL,OH,LL,1H	50-51
7RA 12216-D	Wire assy (distributor terminal primary)-used with OEL-12130 Base assy	1	OL,OH,LL,1H	50-51
8EL 12216	Wire assy (distributor terminal primary)	1	9L,9H	49
	34801-S7 Lockwasher-No. 6	1	9L,9H,OL,OH,LL,1H	49-51
	34051-S7 Nut (hex)-No. 6-32-wiring to breaker arm and bracket	1	OL,OH,LL,1H	50-51
	34079-S7 Nut (hex)-No. 10-32-terminal screw to distributor base	1	OL,OH,LL,1H	50-51
	355176-S7 Screw (fillister hd)-No. 6-32 x 5/32"-primary wire assy to breaker plate	1	9L,9H	49
	350032-S Screw (special head)-No. 10-32 x 27/32"	1	OL,OH	50
	351256-S8 Washer (special)-No. 10-1/32" x 7/16"-terminal screw to distributor base	1	OL,OH,LL,1H	50-51



# Lincoln and Lincoln Cosmopolitan

## CHASSIS PARTS CATALOGUE

PART NUMBER	PART NAME	NO. REQ'D	MODEL	YEAR 19__
<b>Distributor, Circuit Breaker and Distributor Wiring—Continued</b>				
7BA 12225	Spring (distributor diaphragm)	2	OL,OH,LL,LH	50-51
8EL 12225	Spring (distributor diaphragm)	1	9L,9H	49
	356618-S Washer (flat)-5/32" I.D. x 17/32"-O.D.-for vacuum chamber spring	1	9L,9H	49
	356619-S Washer (flat)-5/32" I.D. x 17/32"-O.D. for vacuum chamber spring	1	9L,9H	49
	356620-S Washer (flat)-1/8" I.D. x 17/32" O.D. x 1/16" thick-for vacuum chamber spring	1	9L,9H	49
8EL 12226	Tube (distributor vacuum)	1	9L,9H	49
OEL 12226	Tube (distributor vacuum)	1	OL,OH,LL,LH	50-51
	351112-S Screw (tube)-3/16" O.D.-tube to distributor and carburetor	2	9L,9H,OL,OH,LL,LH	49-51
7RA 12233	Bushing (distributor primary terminal)	1	OL,OH,LL,LH	50-51
7RA 12234	Insulator (distributor primary terminal)	1	OL,OH,LL,LH	50-51
8EL 12242	Plate assy (breaker sub)	1	9L,9H	49
8L 12258-A	Breaker and bracket assy (circuit)-std equipment	1	9L except 76,OL,LL	49-51
8H 12258-A	Breaker and bracket assy (circuit)-std equipment	1	9L76,9H,OH,LH	49-51
8H 12258-A	Breaker and bracket assy (circuit)-used with hydraulic system	1	9L72-74,OL,LL	49-51
	34803-S7 Lockwasher-No. 10-circuit breaker & brkt. assy terminal posts	6	9L,9H,OL,OH,LL,LH	49-51
	34079-S7 Nut (hex)-No. 10-32-circuit breaker & brkt. assy terminal posts	6	9L,9H,OL,OH,LL,LH	49-51
	31527-S7 Screw (hex-hd washer)-No. 14- 10 x 1/2"-circuit breaker to support bracket	2	9L,9H,OL,OH,LL,LH	49-51
	42360-S7 Screw (hex washer head self tapping)-No.10-16 x 3/8"- circuit breaker to brkt.	2	9L,9H,OL,OH,LL,LH	49-51
8EL 12259	Kit (spark plug and coil high tension wire)-consists of the following (1) 8EL-12282 Wire (1) 8EL-12283 Wire (1) 8EL-12284 Wire (1) 8EL-12285 Wire (1) 8EL-12286 Wire (1) 8EL-12287 Wire (1) 8EL-12295 Wire (1) 8EL-12296 Wire (1) 8EL-12298 Wire (10) 2N-12113 Insulators	1	9L,9H,OL,OH,LL,LH	49-51
7RA 12264	Wire assy (distributor breaker ground)	1	OL,OH,LL,LH	50-51
8EL 12264	Wire assy (distributor breaker ground)	1	9L,9H	49
	34801-S7 Lockwasher-No. 6	2	9L,9H,OL,OH,LL,LH	49-51
	355067-S7 Screw and lockwasher assy (fillister head)-No. 8-32 x 5/16"-wire to distributor base	2	OL,OH,LL,LH	50-51
	355176-S7 Screw (fillister head)-No. 6-32 x 5/32"	2	9L,9H,OL,OH,LL,LH	49-51
7RA 12271	MS Retainer (ignition wires)-Rubber-secure locally	2	9L,9H,OL,OH,LL,LH	49-51

# Lincoln and Lincoln Cosmopolitan

## CHASSIS PARTS CATALOGUE

PART NUMBER	PART NAME	NO. REQ'D	MODEL	YEAR
<b>Distributor, Circuit Breaker and Distributor Wiring—Continued</b>				
8EL 12274	Arm (distributor timing)	1	9L,9H,OL,OH,1L,1H	49-51
	34129-S2 Nut (square)-1/4"-20-timing arm to distributor	1	9L,9H,OL,OH,1L,1H	49-51
	31144-S7 Screw (fillister hd)-1/4"-20 x 1-1/4"-timing arm to distributor	1	9L,9H,OL,OH,1L,1H	49-51
8EL 12282	Wire assy (distributor to spark plug No. 5)-27-1/4" long	1	9L,9H,OL,OH,1L,1H	49-51
1EL 12282-A	Wire assy (distributor to spark plug No. 5)-25-1/4" long	1	1L,1H	51
8EL 12283	Wire assy (distributor to spark plug No. 2)-23-3/4" long	1	9L,9H,OL,OH,1L,1H	49-51
1EL 12283-A	Wire assy (distributor to spark plug No. 2)-21-1/4" long	1	1L,1H	51
8EL 12284	Wire assy (distributor to spark plug No. 3)-21" long	1	9L,9H,OL,OH,1L,1H	49-51
1EL 12284-A	Wire assy (distributor to spark plug No. 3)-19" long	1	1L,1H	51
8EL 12285	Wire assy (distributor to spark plug No. 6)-21-1/4" long	1	9L,9H,OL,OH,1L,1H	49-51
1EL 12285-A	Wire assy (distributor to spark plug No. 6)-19-1/2" long	1	1L,1H	51
8EL 12286	Wire assy (distributor to spark plug No. 1)-28-1/2" long	1	9L,9H,OL,OH,1L,1H	49-51
1EL 12286-A	Wire assy (distributor to spark plug No. 1)-24-1/2" long	1	1L,1H	51
8EL 12287	Wire assy (distributor to spark plug No. 4)-21-1/4" long	1	9L,9H,OL,OH,1L,1H	49-51
1EL 12287-A	Wire assy (distributor to spark plug No. 4)-17-3/4" long	1	1L,1H	51
8EL 12295	Wire assy (distributor to spark plug No. 7)-16-3/4" long	1	9L,9H,OL,OH,1L,1H	49-51
1EL 12295-A	Wire assy (distributor to spark plug No. 7)-13-3/4" long	1	1L,1H	51
8EL 12296	Wire assy (distributor to spark plug No. 8)-16-3/4" long	1	9L,9H,OL,OH,1L,1H	49-51
1EL 12296-A	Wire assy (distributor to spark plug No. 8)-15" long	1	1L,1H	51
7RA 12297	Grommet (ignition wiring to bracket)	2	9L,9H,OL,OH,1L,1H	49-51
8EL 12298	Wire assy (coil to distributor)-high tension-7-1/2" long	1	9L,9H,OL,OH,1L,1H	49-51
7RA 12300-B	Condenser assy (distributor)-used with OBA-12150-A	1	OL,OH	50
7RA 12300-C	Condenser assy (distributor)-used with OBA-12150-B	1	1L,1H	51
8EL 12300-A	Condenser assy (distributor)-used with 8EL-12150	1	9L,9H	49
	34801-S7 Lockwasher-No. 6	1	9L,9H,OL,OH,1L,1H	49-51
	34051-S7 Nut (hex)-No. 6-32 condenser to breaker arm and bracket assy	1	OL,OH,1L,1H	50-51
	355067-S7 Screw and lockwasher assy (fillister hd)-No. 8-32 x 5/16"-condenser to breaker plate	1	9L,9H,OL,OH,1L,1H	49-51
	355176-S7 Screw (fillister head)-No. 6-32 x 5/32"	1	9L,9H	49
8EL 12316	Clip (distributor breaker arm spring)	1	9L,9H	49
	36787-S7 Screw (rd-hd)-No. 6-32 x 5/16"-spring clip to breaker assy	1	9L,9H	49

# Lincoln and Lincoln Cosmopolitan

## CHASSIS PARTS CATALOGUE

PART NUMBER	PART NAME	NO. REQ'D	MODEL	YEAR 19__
<b>Distributor, Circuit Breaker and Distributor Wiring—Continued</b>				
8EL 12317	Spacer (distributor cam)	1	9L,9H	49
8EL 12318	Washer (distributor shaft thrust)-upper	1	9L,9H	49
8EL 12319	Spring (distributor governor anti rattle)	1	9L,9H	49
8EL 12320	Gasket (distributor diaphragm vacuum connection)	1	9L,9H	49
8EL 12321	Spring (distributor terminal housing brush)	1	9L,9H	49
8EL 12322	Kit (distributor governor weight spring)	1	9L,9H	49
7RA 12370-B	Diaphragm assy (distributor)-Zinc housing	1	0L,0H,1L,1H	50-51
FAA 12370-A	Diaphragm assy (distributor)-Steel housing	1	0L,0H,1L,1H	50-51
	43243-S8 Screw and lockwasher assy (pan hd)-No. 8-32 x 3/4"	2	0L,0H,1L,1H	50-51
8EL 12370	Diaphragm assy (distributor)	1	9L,9H	49
	34903-S7 Lockwasher-No. 10-diaphragm assy to distributor	2	9L,9H	49
7EH 12382	Connection (distributor diaphragm vacuum)	1	9L,9H	49
7RA 12388	Retainer (diaphragm rod)-used with 8EL-12127	1	0L,0H,1L,1H	50-51
8EL 12388	Retainer (diaphragm rod)-used with 8EL-12127	1	9L,9H	49
6H 12405	Plug assy (spark)-H-10	8	9L,9H,0L,0H,1L,1H	49-51
0LA 12410-A	Gasket (spark plug)	8	9L,9H,0L,0H,1L,1H	49-51
8H 12425	NS Insulator (spark plug)-serviced in 8H-18344 Kit	8	9L,9H,0L,0H,1L,1H	49-51
	8H-18344 Kit (spark plug insulator installation)-consists of the following (8) 8H-12425 Insulators	1	9L,9H,0L,0H,1L,1H	49-51

# Headlamp

8L 13002	Headlamp assy-less bulb	2	9L,9H	49
OL 13002	Headlamp assy-less bulb	2	OL,OH	50
1L 13002-A	Headlamp assy-less bulb	2	1L,1H	51
09A 13007	Bulb assy (headlamp)-Sealed Beam	2	9L,9H,OL,OH,1L,1H	49-51
1L 13008-A	Headlamp assy-less bulb and wiring	2	9L,9H,OL,OH,1L,1H	49-51
	355768-AS2 Nut (spring)-No. 10-headlamp to fender	8	9L,9H,OL,OH,1L,1H	49-51
	32938-S7 Screw (pan head)-No. 10-12 x 5/8"-headlamp case to fender	8	9L,9H,OL,OH,1L,1H	49-51
	7RA-11654 Switch assy (headlamp)-instr. panel	1	9L,9H	49
	OL-11654 Switch assy (lighting control hand)	1	OL,OH,1L,1H	50-51
	OL-11661 Knob and insert assy (headlamp control switch)	1	OL,OH	50
	1L-11661 Knob and insert assy (headlamp control switch)	1	1L,1H	51
	OL-11662 Bezel (headlamp control switch)	1	OL,OH,1L,1H	50-51
	OL-14445-A Wiring assy (headlamp)-RH to LH	1	OL,OH	50
	OL-14445-B Wiring assy (headlamp)-RH to LH	1	OL,OH,1L,1H	50-51
	8L-7004658-G Tray assy (headlamp switch control)	1	9L,9H	49

# Lincoln and Lincoln Cosmopolitan

## CHASSIS PARTS CATALOGUE

### Headlamp—Continued

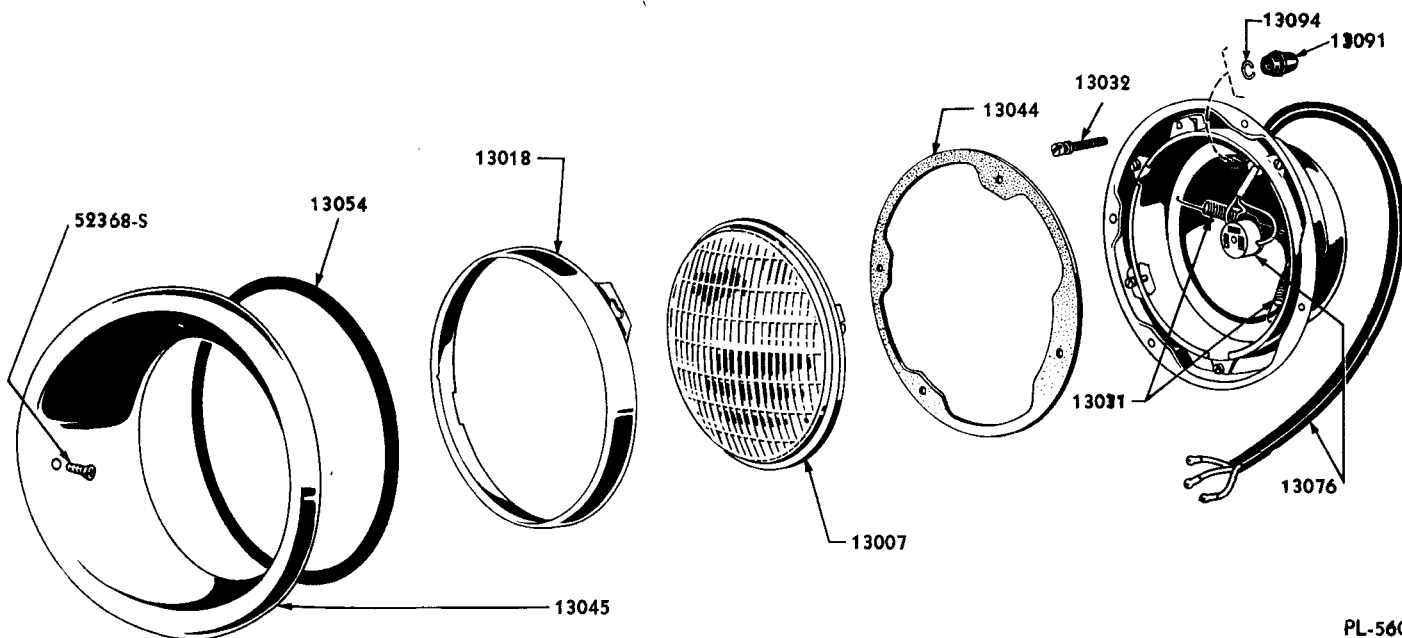

PL-560

### HEADLAMP (8L-13002)

Basic numbers only shown on illustration. Order by Part Numbers shown in list of parts.

PART NUMBER	QTY	PART NAME	NO. REQ'D	MODEL	YEAR 19__
11A 13018-A		Ring (headlamp bulb retaining)-Nickel Chrome-alternate in pairs with OA-13018-C	2	9L,9H,OL,OH,1L,1H	49-51
OA 13018-C		Ring (headlamp bulb retaining)-Copper Chrome-alternate in pairs with 11A-13018-A	2	9L,9H,OL,OH,1L,1H	49-51
		38018-S Screw (fillister head)-No. 8-32 x 5/16"-ring to ball ring	6	9L,9H,OL,OH,1L,1H	49-51
11A 13031		Spring (headlamp bulb ring)	4	9L,9H,OL,OH,1L,1H	49-51
1L 13032-A		Screw (headlamp adjusting)-1/4"-28 x 2"	4	9L,9H,OL,OH,1L,1H	49-51
11A 13044-A		Gasket (headlamp to fender)	2	9L,9H,OL,OH,1L,1H	49-51
8H 13045		Rim (front fender headlamp)-RH	1	9L,9H,OL,OH	49-50
1L 13045		Rim (front fender headlamp)-RH	1	1L,1H	51
8H 13046		Rim (front fender headlamp)-LH	1	9L,9H,OL,OH	49-50
1L 13046		Rim (front fender headlamp)-LH	1	1L,1H	51
		355875-S32 Nut (spring)-No. 8	6	9L,9H,OL,OH,1L,1H	49-51
		52368-S23 Screw (cross recessed oval hd self tapping)-No. 8-15 x 7/8"-headlamp rim to fender	6	9L,9H,OL,OH	49-50
		357848-S Screw (cross recessed oval head)-No. 8-15 x 7/8"-rim to headlamp support	6	1L,1H	51

# Lincoln and Lincoln Cosmopolitan

## CHASSIS PARTS CATALOGUE

PART NUMBER	PART NAME	NO. REQ'D	MODEL	YEAR
<b>Headlamp—Continued</b>				
8L 13054	Seal (headlamp ring)-24-1/2" circumference	2	9L,9H,OL,OH	49-50
1L 13054	Seal (headlamp rim)-25-41/64" circumference	2	1L,1H	51
51A 13076-B	Wiring assy (headlamp leads)-3 bullet type terminals -20" long	2	9L,9H	49
OA 13076	Wiring assy (headlamp leads)-2 bullet type and 1 eyelet type terminals-13-1/2" long	2	OL,OH	50
1L 13076-A	Wiring assy (headlamp leads)-2 bullet type and 1 eyelet type terminals-16-1/2" long	2	OL,OH,1L,1H	50-51
	8L-11653 Wiring assy (headlamp)	1	9L,9H,OL,OH,1L,1H	49-51
	59A-14615 Grommet (headlamp wire thru air deflector)	2	9L,9H	49
	OA-14615-A Grommet (headlamp wire thru air deflector)	2	OL,OH,1L,1H	50-51
HB 13090	Grommet (headlamp dimmer switch)-male	1	9L,9H,OL,OH,1L,1H	49-51
51A 13091-B	NS Grommet (headlamp wire)-Rubber-part of 51A-13076-B	2	9L,9H	49
	8A-13532 Switch assy (headlamp foot dimmer)	1	9L,9H,OL,OH,1L,1H	49-51
	351230-S7 Lockwasher-No. 8	3	9L,9H,OL,OH,1L,1H	49-51
	26457-S7 Screw (rd-hd)-No. 8-32 x 1/4"-wiring to switch	3	9L,9H,OL,OH,1L,1H	49-51
	42817-S8 Screw & lockwasher assy (pan hd)-1/4"-20 x 1/2"-switch to floor	2	9L,9H,OL,OH,1L,1H	49-51
HB 13092	Grommet (headlamp dimmer switch)-female	1	9L,9H,OL,OH,1L,1H	49-51
51A 13094	Ring (headlamp wiring grommet)-part of 51A-13076-B	2	9L,9H	49

## Parking Lamp

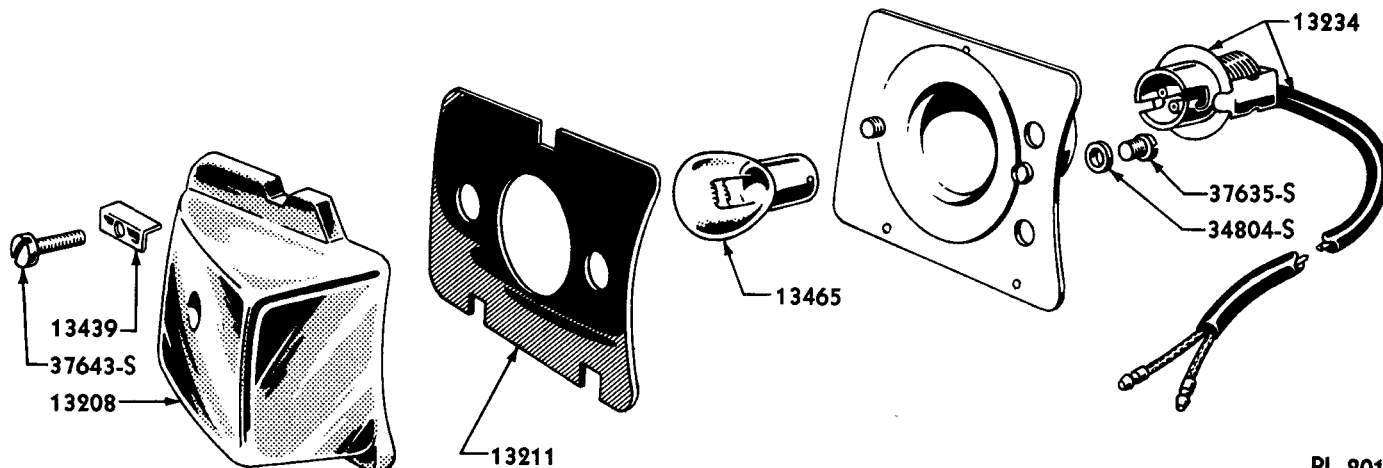

### PARKING LAMP (7EH-13200)

Basic numbers only shown on illustration. Order by Part Numbers shown in list of parts.

PL-201

# Lincoln and Lincoln Cosmopolitan

## CHASSIS PARTS CATALOGUE

### Parking Lamp-Continued

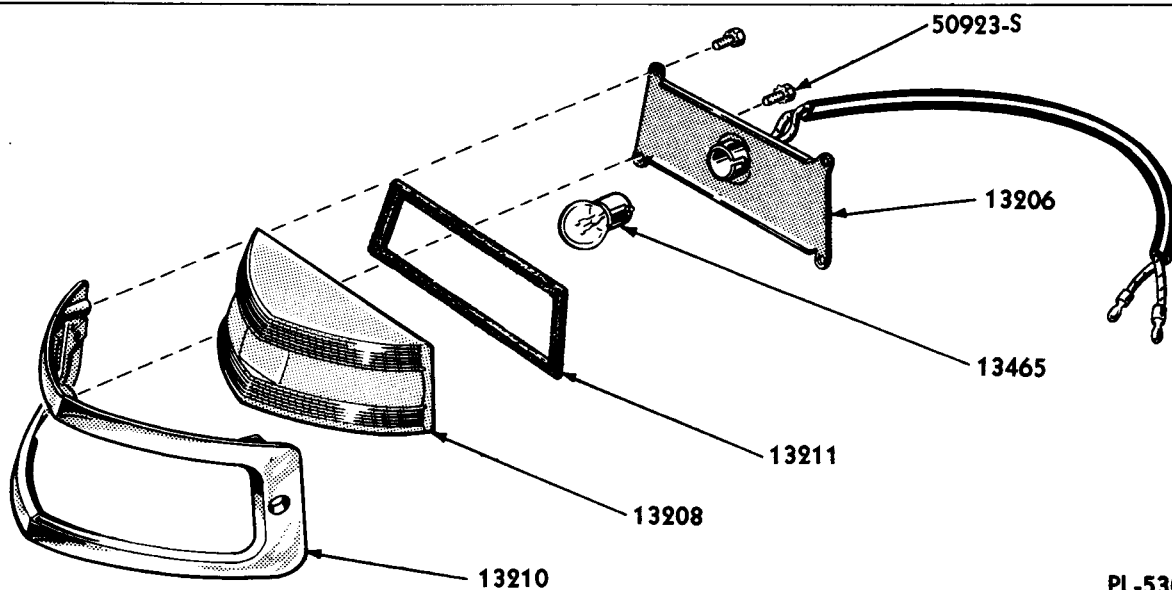

**PARKING LAMP (1L-13200)**

PL-530

Basic numbers only shown on illustration. Order by Part Numbers shown in list of parts.

PART NUMBER	QTY	PART NAME	NO. REQ'D	MODEL	YEAR 19__
7EH 13200		Lamp assy (parking)-RH	1	9L,9H	49
OL 13200		Lamp assy (parking)-RH	1	OL,OH	50
1L 13200		Lamp assy (parking)	2	1L,1H	51
7EH 13201		Lamp assy (parking)-LH	1	9L,9H	49
OL 13201		Lamp assy (parking)-LH	1	OL,OH	50
		356640-S2 Clip (parking lamp wiring to grille mounting bolt)	2	OL,OH,1L,1H	50-51
		358313-S32 Clip (wiring)-lamp wiring to air deflector	2	OL,OH,1L,1H	50-51
		42802-S8 Screw and lockwasher assy (pan head)-No. 10-32 x 3/8"-lamp to radiator grille	6	OL,OH	50
		50399-S23 Screw (cross recessed head)-No. 10-32 x 1/2"-lamp to grille extension	4	1L,1H	51
OL 13206		Body & wiring assy (parking lamp)-RH-with box type body	1	OL,OH	50
1L 13206		Body & wiring assy (parking lamp)-with plate type body	2	1L,1H	51
OL 13207		Body & wiring assy (parking lamp)-LH-with box type body	1	OL,OH	50
7EH 13208		Lens (parking lamp)-RH-"LPT-48"	1	9L,9H	49
OL 13208		Lens (parking lamp)-RH-"LPT-50-RH"	1	OL,OH	50
1L 13208		Lens (parking lamp)-"LPT-51"	2	1L,1H	51
7EH 13209		Lens (parking lamp)-LH-"LPT-48"	1	9L,9H	49
OL 13209		Lens (parking lamp)-LH-"LPT-50-LH"	1	OL,OH	50
		351230-S7 Lockwasher-No. 8	6	9L,9H	49
		37643-S7 Screw (fillister head)-No. 6-32 x 9/16"	6	9L,9H	49

# Lincoln and Lincoln Cosmopolitan

## CHASSIS PARTS CATALOGUE

PART NUMBER	PART NAME	NO. REQ'D	MODEL	YEAR
<b>Parking Lamp—Continued</b>				
1L 13210	Door (parking lamp)	2	1L,1H	51
	50923-58 Screw and washer (cross recessed fillister head)-No. 8-32 x 3/8"-door, lens and gasket to lamp body	8	1L,1H	51
7EH 13211	Gasket (parking lamp lens)-3 holes	2	9L,9H	49
OL 13211	Gasket (parking lamp lens)-2-1/64" x 4-29/32" rectangular	2	OL,OH	50
1L 13211	Gasket (parking lamp lens)-5-5/32" x 4-37/64" x 2-3/16" trapezoidal	2	1L,1H	51
7EH 13234	Wiring and socket assembly (parking lamp)	2	9L,9H	49
	11A-13465 Bulb-21-3 C.P.-parking lamp	2	9L,9H,OL,OH,1L,1H	49-51
OL 13236	Door (parking lamp)-RH	1	OL,OH	50
OL 13237	Door (parking lamp)-LH	1	OL,OH	50
OA 13247	Screw (parking lamp lens retaining)-No. 8-32-oval head cross recessed	2	OL,OH	50

## Directional Turn Signal

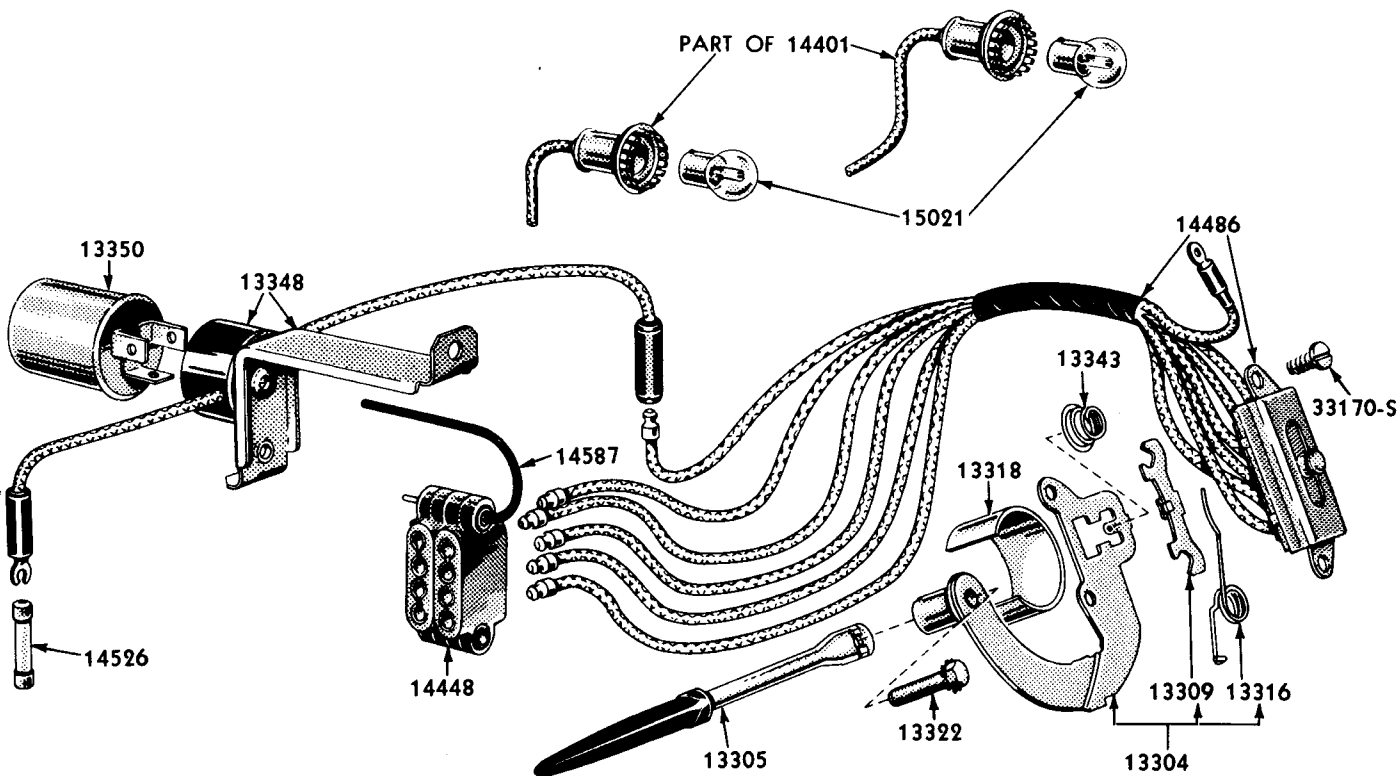

PL-635

## DIRECTIONAL TURN SIGNAL

Basic numbers only shown on illustration. Order by Part Numbers shown in list of parts.



# Lincoln and Lincoln Cosmopolitan

## CHASSIS PARTS CATALOGUE

PART NUMBER	PART NAME	NO. REQ'D	MODEL	YEAR 19__
<b>Directional Turn Signal-Continued</b>				
8L 13304	Plate assy (turn signal switch)	1	9L,9H,OL,OH	49-50
1M 13304-A	Plate assy (turn signal switch)	1	1L,1H	51
	8L-14486 Switch & wiring (turn signal)	1	9L,9H	49
	OL-14486 Switch & wiring (turn signal)	1	OL,OH	50
	1M-14486-A Switch & wiring (turn signal)	1	1L,1H	51
	33170-S8 Screw (pan head self tapping)-No. 10-16 x 1/4"	2	9L,9H,OL,OH,1L,1H	49-51
NS	8A-14526 Fuse (turn signal)-14 amp.-serviced in APA-14527-D Kit	1	9L,9H,OL,OH,1L,1H	49-51
8L 13305-AA	Handle & shank assy (turn signal switch)-Gold Fleck Dark Gray	1	9L,9H	49
8L 13305-AB	Handle & shank assy (turn signal switch)-used with Green interiors	1	9L,9H	49
8L 13305-AC	Handle & shank assy (turn signal switch)-used with Blue interiors	1	9L,9H	49
8L 13305-AD	Handle & shank assy (turn signal switch)-used with Tan interiors	1	9L,9H	49
8L 13305-AD	Handle & shank assy (turn signal switch)-used with Maroon and Yellow interiors	1	9H76	49
OM 13305	Handle and shank assy (turn signal switch)-Black Handle with Chrome Shank	1	OL,OH	50
1M 13305-A	Handle and shank assy (turn signal switch)-Black Handle with rounded end Chrome Shank	1	1L,1H	51
1M 13305-B	Handle and shank assy (turn signal switch)-Oyster White handle with rounded end Chrome shank	1	1L,1H	51
8L 13309-B	Pawl (turn signal switch)-1-3/16" overall length	1	9L,9H,OL,OH	49-50
1M 13309-A	Pawl (turn signal switch)-1-11/16" overall length	1	1L,1H	51
8L 13316	Spring (turn signal switch pawl)-3 coils	1	9L,9H,OL,OH	49-50
1M 13316-A	Spring (turn signal switch pawl)-3-1/2" coils	1	1L,1H	51
8L 13318-A	Cam (directional signal turn-off)-15/16" length	1	9L,9H,OL,OH,1L,1H	49-51
1A 13318-A	Cam (directional signal turn off)-1" length	1	9L,9H,OL,OH,1L,1H	49-51
OM 13322	Screw & washer assy (turn signal handle and shank to steering column)-No. 10-32 x 1-1/4"	1	OL,OH,1L,1H	50-51
1M 13343-A	Spring (turn signal switch plate retainer)	1	1L,1H	51
OL 13348	Bracket assy (turn signal flasher)	1	OL,OH,1L,1H	50-51
	42360-S7 Screw (hex washer head self tapping)-No. 10-16 x 3/8"-bracket to instrument panel	1	OL,OH,1L,1H	50-51
8L 13350-B	Flasher assy (direction turn signal)-plug in type	1	9L,9H,OL,OH,1L,1H	49-51
	48-15021 Bulb (direction turn signal)-1 C.P.-SC	2	9L,9H,OL,OH,1L,1H	49-51
8L 13351	Clamp (direction signal flasher)	1	9L,9H	49

# Lincoln and Lincoln Cosmopolitan

## CHASSIS PARTS CATALOGUE

### Rear Lamp

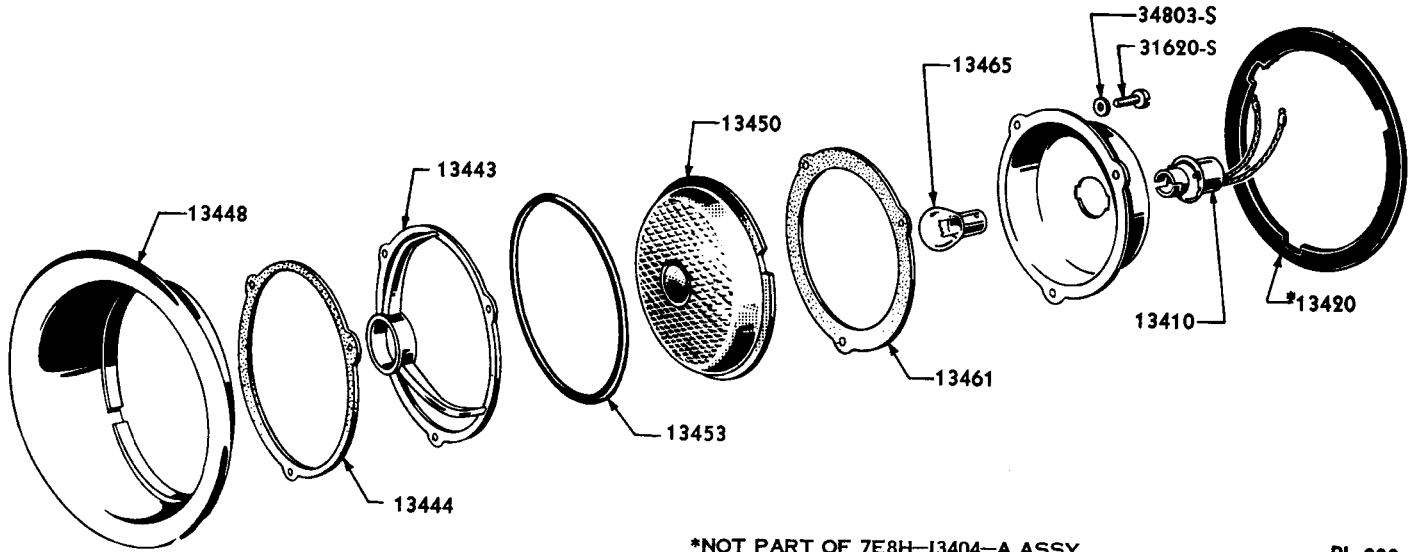

\*NOT PART OF 7E8H-13404-A ASSY.

PL-200

### REAR LAMP (7E8H-13404)

Basic numbers only shown on illustration. Order by Part Numbers shown in list of parts.

PART NUMBER	QTY	PART NAME	NO. REQ'D	MODEL	YEAR
7E8H 13404-A		Lamp assy (rear)-RH	1	9H,0H	49-50
8L 13404-A		Lamp assy (rear)-RH	1	9L,0L	49-50
1H 13404		Lamp assy (rear)-RH	1	1H	51
1L 13404		Lamp assy (rear)	2	1L	51
7E8H 13405-A		Lamp assy (rear)-LH	1	9H,0H	49-50
8L 13405-A		Lamp assy (rear)-LH	1	9L,0L	49-50
1H 13405		Lamp assy (rear)-LH	1	1H	51
		1H-13516 Clamp (rear lamp mounting)-upper-RH	1	1H	51
		1H-13517 Clamp (rear lamp mounting)-upper-LH	1	1H	51
		1L-13517 Clamp (rear lamp mounting)-upper	2	1L	51
		1H-13518 Clamp (rear lamp mounting)-lower	2	1H	51
		1L-13518 Clamp (rear lamp mounting)-lower	2	1L	51
		22994-S8 Bolt (square head)-1/4"-20 x 7/8"-lamp to body	8	1L,1H	51
		34905-S7 Lockwasher-1/4"-lamp to body	8	1L,1H	51
		33795-S7 Nut (hex)-1/4"-20-lamp to body	8	1L,1H	51
		37657-S8 Screw (fillister hd)-No. 12-24 x 1/2"-lamp assy to car body	6	9L,9H,0L,0H,1L,1H	49-51

# Lincoln and Lincoln Cosmopolitan

## CHASSIS PARTS CATALOGUE

### Rear Lamps—Continued

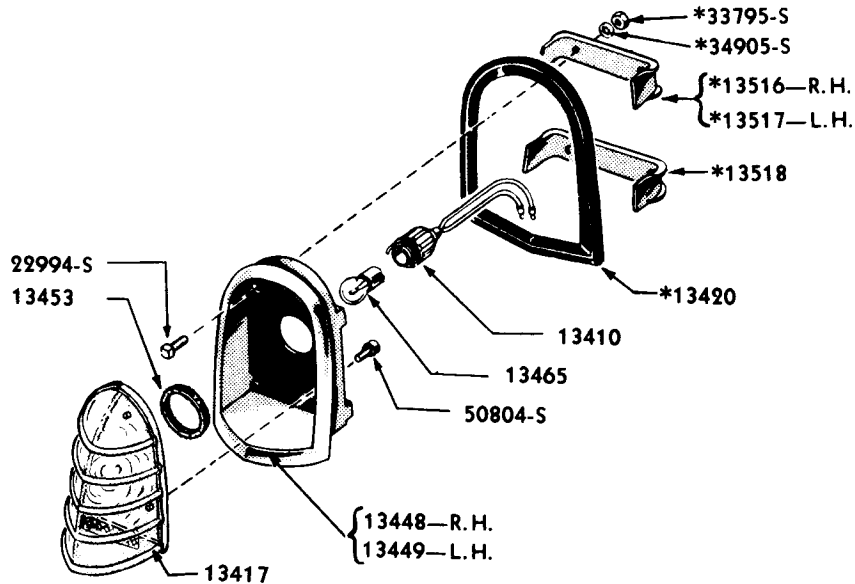

\*NOT PART OF 1L-13404 ASSY

PL-587

### REAR LAMP (1L-13404)

Basic numbers only shown on illustration. Order by Part Numbers shown in list of parts.

PART NUMBER	QTY	PART NAME	NO. REQ'D	MODEL	YEAR 19
7E8H 13410		Wiring and socket assy (rear lamp)	2	9L,9H,OL,OH	49-50
8M 13410-A		Wiring and socket assy (rear lamp)	2	1L,1H	51
8M 13412		Wiring and socket assy (rear license lamp)-partial socket	1	9L,9H,OL,OH,1L,1H	49-51
1M 13412-A		Wiring and socket assy (rear license lamp)	1	9L,9H,OL,OH,1L,1H	49-51
1L 13417-A		Body, lens and reflector assy (rear lamp)	2	1L,1H	51
		50804-S8 Screw and lockwasher (cross recessed pan head)-No. 10-32 x 3/8"-lamp body to door	6	1L,1H	51
7E8H 13420		Pad (rear lamp mounting)	2	9L,9H,OL,OH	49-50
1H 13420-B		Pad (rear lamp mounting)	2	1H	51
1L 13420		Pad (rear lamp mounting)	2	1L	51
21A 13439	NS	Retainer (parking lamp lens)-make locally	6	9L,9H	49
7E8H 13443		Door (rear lamp)-inner	2	9L,9H,OL,OH	49-50
7E8H 13444		Gasket (rear lamp)	2	9L,9H,OL,OH	49-50
7E8H 13448		Rim (rear lamp)-RH-2" deep	1	9H,OH	49-50
8L 13448		Rim (rear lamp)-RH-1-1/2" deep	1	9L,OL	49-50

# Lincoln and Lincoln Cosmopolitan

## CHASSIS PARTS CATALOGUE

### Rear Lamps—Continued

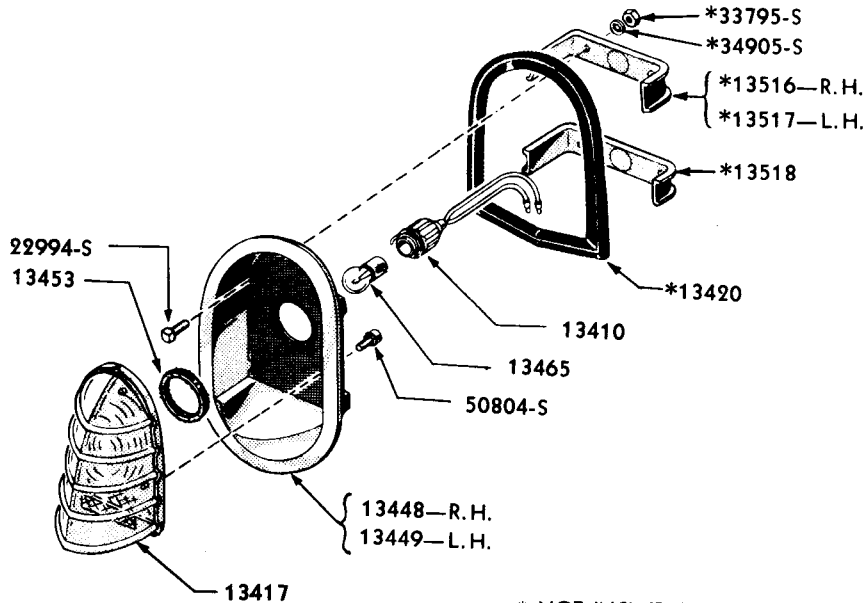

\* NOT INCLUDED IN 1H-13404-5 ASSY.

PL-588

### REAR LAMPS (1H-13404-5)

Basic numbers only shown on illustration. Order by Part Numbers shown in list of parts.

PART NUMBER	QTY	PART NAME	NO. REQ'D	MODEL	YEAR 19__
1H 13448		Door (rear lamp)-RH	1	1H	51
1L 13448		Door (rear lamp)	2	1L	51
7E8H 13449		Rim (rear lamp)-LH-2" deep	1	9H, 0H	49-50
8L 13449		Rim (rear lamp)-LH-1-1/2" deep	1	9L, 0L	49-50
1H 13449		Door (rear lamp)-LH	1	1H	51
		31620-S7 Bolt (fillister head)-No. 10-32 x 9/16"-door to lamp body	6	9L, 9H, 0L, 0H	49-50
		34803-S7 Washer (lock)-No. 10-door to lamp body	6	9L, 9H, 0L, 0H	49-50
7E8H 13450-A		Lens (rear lamp)-Red-"LRST-48"	2	9L, 9H, 0L, 0H	49-50
7E8H 13453		Gasket (rear lamp waterseal)-3-1/2" I.D.	2	9L, 9H, 0L, 0H	49-50
1M 13453		Gasket (rear lamp)-water seal-1-39/64" I.D. x 2-7/64" O.D.	2	1L, 1H	51
7E8H 13461		Gasket (rear lamp)-3-29/32" I.D.-5/64" thick	2	9L, 9H, 0L, 0H	49-50

# Lincoln and Lincoln Cosmopolitan

## CHASSIS PARTS CATALOGUE

PART NUMBER	PART NAME	NO. REQ'D	MODEL	YEAR 19__
<b>Rear Lamp—Continued</b>				
8A 13464	Bulb (dome lamp)-6 C.P.-D.C.	1	9L,9H,OL,OH,LL,1H	49-51
B 13465	Bulb (backup lamp)-21 C.P.-S.C.	2	9L,9H,OL,OH,LL,1H	49-51
11A 13465	Bulb (rear lamp)-21-3 C.P.-offset pin base	2or4	9L,9H,OL,OH,LL,1H	49-51
11A 13465	Bulb (parking lamp)-21-3 C.P.-offset pin base	2	9L,9H,OL,OH,LL,1H	49-51
51A 13465	Bulb (utility lamp)-15 C.P.-D.C.	1	9L,9H,OL,OH,LL,1H	49-51
B 13466	Bulb (license plate lamp)-3 C.P.-S.C.	1	9L,9H,OL,OH,LL,1H	49-51
B 13466	Bulb (luggage compartment lamp)-3 C.P.-S.C.	1	9L,9H,OL,OH,LL,1H	49-51
78 13466	Bulb (instrument cluster)-2 C.P.-S.C.	2	9L,9H,OL,OH,LL,1H	49-51
78 13466	Bulb (speedometer)-2 C.P.-S.C.	1	9L,9H,OL,OH,LL,1H	49-51
78 13466	Bulb (glove box)-2C.P.-S.C.	1	9L,9H,OL,OH,LL,1H	49-51
78 13466	Bulb (clock)-2 C.P.-S.C.	1	9L,9H,OL,OH,LL,1H	49-51
78 13466	Bulb (hand brake signal)-2 C.P.-S.C.	1	9L,9H,OL,OH,LL,1H	49-51
91A 13480	Switch assy (stop light)	1	9L,9H,OL,OH,LL,1H	49-51

### Luggage Compartment Lamp

8M 13506	Lamp assy (luggage compartment)	1	9L,9H,OL,OH	49-50
1M 13506	Lamp assy (luggage compartment)	1	1L,1H	51
	B-13466 Bulb (luggage compt.)-3 C.P.-S.C.	1	9L,9H,OL,OH,LL,1H	49-51
1H 13516	Clamp (rear lamp mounting)-upper-RH	1	1H	51
1H 13517	Clamp (rear lamp mounting)-upper-LH	1	1H	51
1L 13517	Clamp (rear lamp mounting)-upper	2	1L	51
1H 13518	Clamp (rear lamp mounting)-lower	2	1H	51
1L 13518	Clamp (rear lamp mounting)-lower	2	1L	51
8A 13532	Switch assy (foot dimmer)	1	9L,9H,OL,OH,LL,1H	49-51
	352301-S8 Screw and lockwasher assy (binding head)-1/4"-20 x 3/4" -switch to cover plate	2	9L,9H,OL,OH,LL,1H	49-51
8M 13546	Switch and wiring assy (luggage compartment lamp)	1	9L,9H	49
OM 13546	Switch and wiring assy (luggage compartment lamp)	1	9L,9H,OL,OH,LL,1H	49-51
	356687-S32 Clip (luggage compartment lamp wire to rib brace)	2	OL,OH,LL,1H	50-51
	34902-S7 Lockwasher-(internal tooth)- 1/4"	1	9L,9H,OL,OH,LL,1H	49-51
	37611-S7 Screw (fillister head)-No. 8-32 x 1/4"	1	9L,9H,OL,OH,LL,1H	49-51
8M 13547	Lens and retainer (luggage compartment lamp)	1	9L,9H,OL,OH,LL,1H	49-51
OM 13549	Wiring assy (luggage compartment lamp)	1	OL,OH,LL,1H	50-51

# Lincoln and Lincoln Cosmopolitan

## CHASSIS PARTS CATALOGUE

### Rear License Lamp

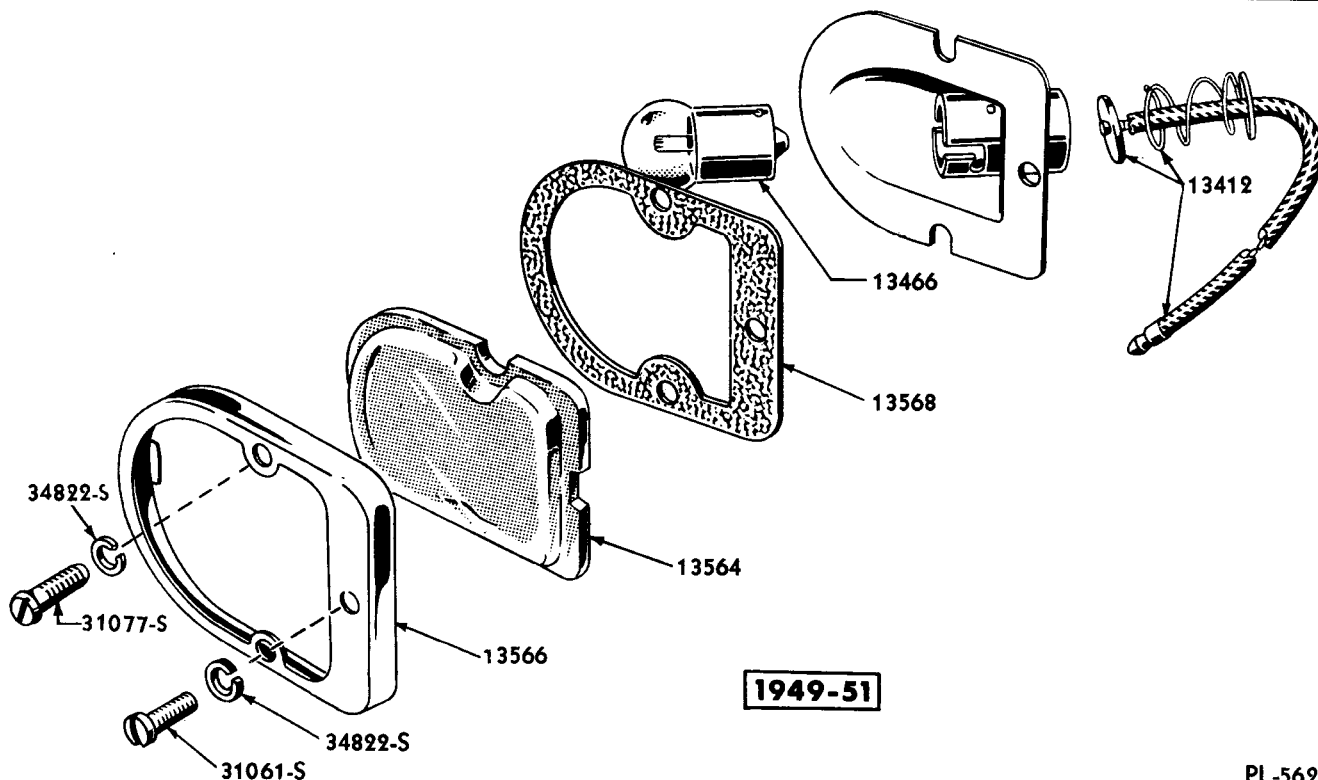

### LICENSE PLATE LAMP (8M-13550)

PL-562

Basic numbers only shown on illustration. Order by Part Numbers shown in list of parts.

PART NUMBER	QUANTITY	PART NAME	NO. REQ'D	MODEL	YEAR
8M 13550		Lamp assy (license plate)-with 8M-13412 assy	1	9L,9H,OL,OH,1L,1H	49-51
1M 13550-A		Lamp assy (license plate)-with 1M-13412-A assy	1	9L,9H,OL,OH,1L,1H	49-51
		B-13466 Bulb (lic. plate lamp)-3 C.P.-S.C.	1	9L,9H,OL,OH,1L,1H	49-51
		8M-13412 Wiring and socket assy (license plate lamp)-partial socket	1	9L,9H,OL,OH,1L,1H	49-51
		1M-13412-A Wiring and socket assy (rear license lamp)	1	9L,9H,OL,OH,1L,1H	49-51
		356640-S2 Clip (license plate lamp wire to stone deflector)	1	9L,9H,OL,OH,1L,1H	49-51
		34822-S7 Lockwasher-No. 8	2	9L,9H	49
		31077-S8 Screw (fillister head)-No. 8-3/2 x 5/8"-lamp to license plate guard	2	9L,9H	49
		50929-S8 Screw and washer (pan head)-No. 8-3/2 x 1/2"-lamp to bumper guard	2	OL,OH,1L,1H	50-51
7RA 13564		Lens (license plate lamp)	1	9L,9H,OL,OH,1L,1H	49-51
7RA 13566		Rim (license plate lamp)	1	9L,9H,OL,OH,1L,1H	49-51
		34822-S7 Lockwasher-No. 8	1	9L,9H,OL,OH,1L,1H	49-51
		31061-S8 Screw (fillister head)-No. 8-3/2 x 1/2"	1	9L,9H,OL,OH,1L,1H	49-51
		50929-S8 Screw and lockwasher (fillister head)-No. 8-3/2 x 1/2"-door to lamp body	1	1L,1H	51

# Lincoln and Lincoln Cosmopolitan

## CHASSIS PARTS CATALOGUE

PART NUMBER	QUANTITY	PART NAME	NO. REQ'D	MODEL	YEAR
-------------	----------	-----------	-----------	-------	------

### Rear License Lamp—Continued

7RA 13568		Gasket (license plate lamp)	1	9L,9H,OL,OH,LL,1H	49-51
OL 13584		Jewel and housing assy (instrument panel cluster signal lamp)	2	OL,OH,LL,1H	50-51
OL 13589	NS	Baffle (instrument panel cluster signal lamp)-3/4" I.D. x 55/64" wide-Paper-secure locally	2	OL,OH,LL,1H	50-51

### Courtesy Lamps

8L 13706	NS	Lamp assy (front compartment courtesy)-service details-consists of the following (2) A-13987 Bulb (2) 8L-13716-A Lens & rim (2) 8L-13720 Socket & wiring	2	9L,9H	49
OL 13706	NS	Lamp assy (front compartment courtesy)-service details-consists of the following (2) A-13987 Bulb (2) 8L-13716-A Lens & Rim (2) OL-13720 Socket & Wiring	2	OL,OH,LL,1H	50-51
		42360-87 Screw (hex head)-No. 10-16 x 3/8"-lamp to instrument panel	2	OL,OH,LL,1H	50-51
		52729-88 Screw (cross recess pan head)-No. 14-10 x 1/2"	2	9L,9H	49
8H 13707		Lamp assy (courtesy lamp)-rear compartment-consists of the following (2) A-13987 Bulb (2) 8H-13709 Body & wire (2) 8H-13723 Lens & bezel	1	9H73-74	49
		32789-88 Screw (flat hd self tapping)-No. 4-24 x 1/2"-courtesy lamp to quarter trim panel	4	9H	49
8M 13708		Wiring assy (front window switches to body harness)	1	9L72-74,OL72-74,LL72-74	49-51
8L 13710		Wiring assy (instrument lamp)	1	9L,9H,OL,OH	49-50
8M 13713		Switch assy (courtesy lamp)	2or4	9L,9H,OL,OH,LL,1H	49-51
8L 13716-A		Lens and rim assy (courtesy lamp)-instrument panel	2	9L,9H,OL,OH,LL,1H	49-51
8L 13720		Socket and wiring assy (courtesy lamp)-instr. panel	2	9L,9H	49
OL 13720		Socket and wiring assy (courtesy lamp)-instr. panel	2	OL,OH,LL,1H	50-51
		8A-13464 Bulb-6 C.P.-D.C.-instrument panel courtesy lamp	2	9L,9H,OL,OH,LL,1H	49-51
		52729-88 Screw (cross recessed pan head self tapping)-No. 14 x 1/2"	2	9L,9H,OL,OH	49-50
8H 13723		Lens and bezel assy (courtesy lamp)-rear compartment	2	9H73-74,OH74	49-50
		8L-14413 Switch, socket & wiring assy (glove compartment lamp)	1	9L,9H,OL,OH,LL,1H	49-51
40 13730		Bulb (map light)-6 C.P.-S.C.	2	9L,9H,OL,OH,LL,1H	49-51
40 13730		Bulb (dome lamp)-6 C.P.-S.C.	1	9L76,9H76,OH76,1H76	49-51
1L 13730		Bulb (dome lamp)-15 C.P.-D.C.	1	LL,1H except 76	51
1H 13731-A		Lens (courtesy lamp)-rear compartment	1	1H74	51

# Lincoln and Lincoln Cosmopolitan

## CHASSIS PARTS CATALOGUE

PART NUMBER	PART NAME	NO. REQ'D	MODEL	YEAR
<b>Courtesy Lamp-Continued</b>				
8L 13740	Switch assy (instrument panel lights)	1	9L,9H	49
OL 13740	Switch assy (instrument panel lights)	1	OL,OH,1L,1H	50-51
	351230-S7 Lockwasher-No. 8	2	9L,9H	49
	34802-S7 Lockwasher-No. 8-switch to light switch	2	9L,9H,OL,OH,1L,1H	49-51
	356023-S13 Nut (special)-7/16"-28-switch to instrument panel	1	9L,9H	49
	26457-S7 Screw (rd-hd)-No. 8-32 x 1/4"-wiring to switch	2	9L,9H,OL,OH,1L,1H	49-51
	A-13987 Bulb (courtesy lamps)-3 C.P.-D.C.	4	9L,9H,OL,OH,1L,1H	49-51

## Dome Lamp

	1L-13776 Lamp assy (dome)	1	1L,1H, except 76	51
	1L-13730 Bulb (dome lamp)-15 C.P.-D.C.	1	1L,1H, except 76	51
	7EH-13777 Lamp assy (dome)	1	9L,9H,OL,OH, except 76	49-50
	40-13730 Bulb 6 C.P.-S.C.-dome lamp	1	9L76,9H76,OH76,1H76	49-51
	8A-13464 Bulb (dome lamp)-6 C.P.-D.C.	1	9L,9H,OL,OH,1L,1H, except 76	49-51
	32914-S8 Screw (pan head self tapping)-No. 6-18 x 3/8"-lamp assy to roof support	3	9H,OH, except 76	49-50
	40500-S7 Screw (pan head self tapping)-No. 6-32 x 1/4"	3	9L,OL, except 76	49-50
	1L-13779 Door assy (dome lamp)	1	1L,1H, except 76	51
	7EH-13783 Lens (dome lamp)	1	9L,9H,OL,OH, except 76	49-50
	8L-13783 Lens (dome lamp)	1	9L76,9H76,OH76,1H76	49-51
	1L-13783 Lens (dome lamp)	1	1L,1H, except 76	51
	7EH-13784 Retainer (dome lamp lens)	1	9L,9H,OL,OH, except 76	49-50
	8L-13788 Door (dome lamp)	1	9L76,9H76,OH76,1H76	49-51
	8L-13793 Socket assy (dome lamp)	1	9L76,9H76,OH76,1H76	49-51
	34938-S7 Lockwasher-No. 8-socket to roof bow	2	9L76,9H76,OH76,1H76	49-51
	33104-S8 Screw (rd-hd self tapping)-No. 8-18 x 1/4"	2	9L76,9H76,OH76,1H76	49-51
	52342-S13 Screw (oval head self tapping)-No. 6-18 x 1/2"	2	9L76,9H76,OH76,1H76	49-51
8M 13752-A	Switch assy (dome lamp)	1	9L,9H,OL,OH,1L,1H, except 76	49-51
	5EH-13770 Escutcheon (dome lamp switch)	1	9L,9H,OL,OH,1L,1H, except 76	49-51
8H 13752-A	Switch and housing assy (dome lamp)	1	9L76,9H76	49
OH 13752	Switch and housing assy (dome lamp)	1	OH76,1H76	50-51
OM 13752	Switch assy (dome lamp)	1	OL,OH,1H, except 76	50-51
	52342-S13 Screw (cross recessed oval head self tapping)-No. 6-18 x 1/2"-switch to pillar	2	9L,9H,OL,OH,1L72	49-51
	52358-S23 Screw (oval head)-No. 6-18 x 3/4"-switch to pillar	2	OL74,OH72-74,1H72-74	50-51
8H 13754	Switch assy (dome lamp)-less housing	1	9L76,9H76,OH76,1H76	49-51
	34801-S7 Lockwasher-No. 6	2	9L76,9H76,OH76,1H76	49-51
	34051-S7 Nut (hex)-No. 6-32	2	9L76,9H76,OH76,1H76	49-51



# Lincoln and Lincoln Cosmopolitan

## CHASSIS PARTS CATALOGUE

PART NUMBER	PART NAME	NO. REQ'D	MODEL	YEAR
<b>Map Light</b>				
8L 13756	Lamp assy (map)-complete	1	9L,9H,OL,OH,1L,1H	49-51
OL 13761	Lens (map lamp)	1	OL,OH,1L,1H	50-51
	41541-S8 Screw (pan head self tapping)- No. 8-32 x 1/4"-lens to instrument panel	1	OL,OH,1L,1H	50-51
8L 13764	Switch assy (map lamp)	1	9L,9H	49
OL 13764	Switch assy (map lamp)	1	OL,OH,1L,1H	50-51
	8L-15650 Map light assy (instrument control panel)	1	9L,9H	49
	OL-15650 Socket and wiring (map light)	1	OL,OH,1L,1H	50-51
	40-13730 Bulb (map light)-6 C.P.-S.C.	1	9L,9H,OL,OH,1L,1H	49-51
	8L-7004658-B Tray assy (map light control)	1	9L,9H	49
	351230-S7 Lockwasher-No. 8	2	9L,9H	49
	351038-S8 Nut (hex)-7/16"-28-switch to instrument panel	2	9L,9H	49
	26457-S7 Screw (round head)-No. 8-32 x 1/4"-wiring to switch	2	9L,9H	49
	40516-S8 Screw (pan head self tapping)- No. 10-32 x 3/8"	2	9L,9H,OL,OH,1L,1H	49-51
	51145-S13 Screw (cross recessed flat head self tapping)-No. 6-32 x 1/4"	2	OL,OH,1L,1H	50-51
	350009-S8 Screw (socket head set)-No. 8- 32 x 5/16"	1	9L,9H	49
5EH 13770	Escutcheon (dome lamp switch)	1	9L,9H,OL,OH,1L,1H, except 76	49-51
	31527-S7 Screw (hex washer head self tapping)-No. 14-14 x 1/2"	2	9L,9H,OL,OH,1L,1H, except 76	49-51
1L 13776	Lamp assy (dome)	1	1L,1H except 76	51
7EH 13777	Lamp assy (dome)	1	9L,9H,OL,OH, except 76	49-50
1L 13779	Door assy (dome lamp)-7" overall length	1	1L,1H, except 76	51
7EH 13783	Lens (dome lamp)-4" diameter-circular	1	9L,9H,OL,OH, except 76	49-50
8L 13783	Lens (dome lamp)-1-3/4" x 5-13/64"-rectangular	1	9L76,9H76,OH76,1H76	49-51
1L 13783	Lens (dome lamp)-4-21/32" overall length-with one radial end	1	1L,1H, except 76	51
7EH 13784	Retainer (dome lamp lens)	1	9L,9H,OL,OH, except 76	49-50
8L 13788	Door (dome lamp)-6-1/2" overall length	1	9L76,9H76,OH76,1H76	49-51
8L 13793	Socket assy (dome lamp)	1	9L76,9H76,OH76,1H76	49-51
B 13799	Bulb (engine compartment lamp)-15 C.P.	1	9L,9H,OL,OH,1L,1H	49-51
	33104-S8 Screw (rd-hd)-No. 8-18 x 1/4"- socket to roof bow	2	OH76,1H76	50-51

# Lincoln and Lincoln Cosmopolitan

## CHASSIS PARTS CATALOGUE

### Horn

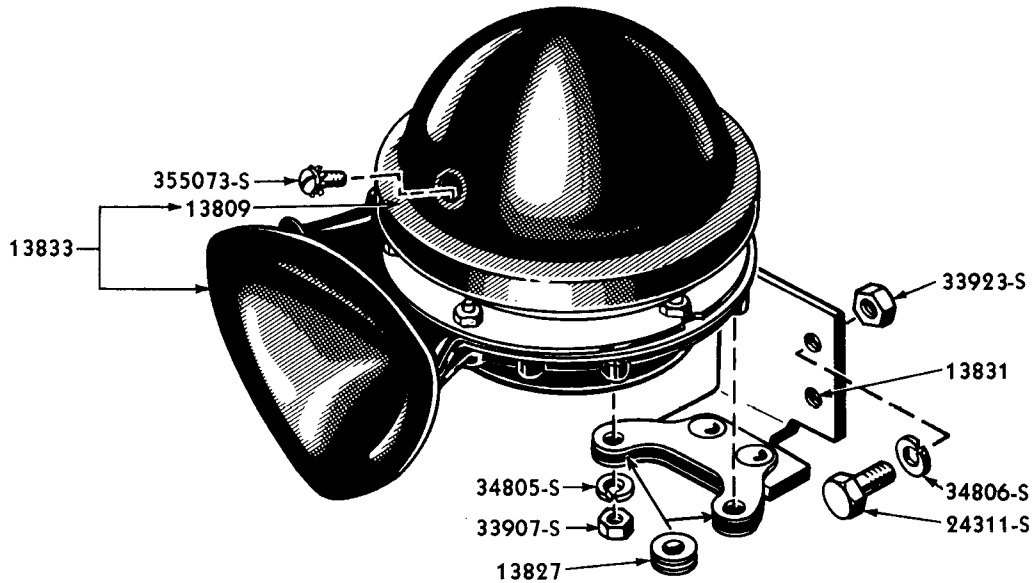

PL-626

### HORN AND BRACKET (SEA SHELL TYPE)

Basic numbers only shown on illustration. Order by Part Numbers shown in list of parts.

PART NUMBER	QTY	PART NAME	NO. REQ'D	MODEL	YEAR 19__
8L 13801-A		Horn & bracket assy-high pitch-RH-Sperks Withington design-with spacer between horn bracket springs at horn bolt holes-Sea Shell type	1	9L,9H,OL,OH	49-50
8L 13801-B	NS	Horn & bracket assy-high pitch-RH-Auto Lite design-without spacer between horn bracket springs at horn bolt holes-Sea Shell type-replaced by 8L-13801-A	1	9L,9H,OL,OH	49-50
OL 13801-A		Horn & bracket assy-low pitch-RH-21-3/4" developed length-Trumpet type	1	OL,OH,LL,LH	50-51
8L 13802-A		Horn & bracket assy-low pitch-LH-Sperks Withington design-with spacer between horn bracket springs at horn bolt holes-Sea Shell type	1	9L,9H,OL,OH	49-50
8L 13802-B	NS	Horn & bracket assy-low pitch-LH-Auto Lite design-without spacer between horn bracket springs at horn bolt holes-Sea Shell type-replaced by 8L-13802-A	1	9L,9H,OL,OH	49-50
OL 13802-A		Horn & bracket assy-high pitch-LH-15-1/4" developed length-Trumpet type	1	OL,OH,LL,LH	50-51

# Lincoln and Lincoln Cosmopolitan

## CHASSIS PARTS CATALOGUE

### Horns—Continued

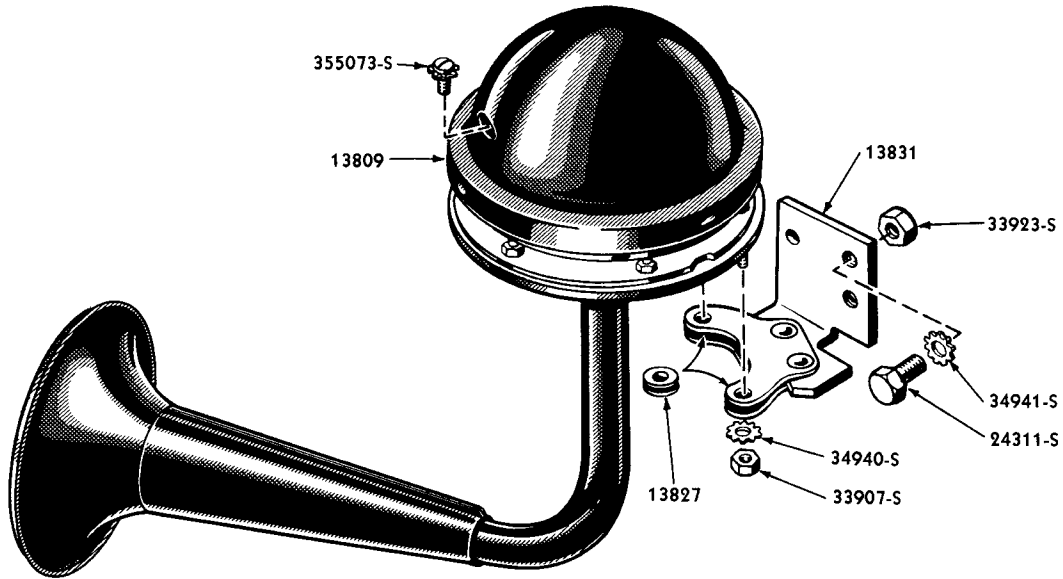

PL-627

### HORN AND BRACKET (TRUMPET TYPE)

Basic numbers only shown on illustration. Order by Part Numbers shown in list of parts.

PART NUMBER	QUANTITY	PART NAME	NO. REQ'D	MODEL	YEAR 19__
51A 13809-A		Cover (horn motor)-Sparks Withington design-Sea Shell type	2	9L,9H,OL,OH	49-50
51A 13809-B		Cover (horn motor)-Auto Lite design-Sea Shell type	2	9L,9H,OL,OH	49-50
OL 13809-A		Cover (horn motor)-Trumpet type horn	2	OL,OH,LL,1H	50-51
51A 13827-A		Spacer (horn bracket)-15/64" thick	4	9L,9H,OL,OH,LL,1H	49-51
51A 13827-B		Spacer (horn bracket)-11/64" thick	4	9L,9H,OL,OH,LL,1H	49-51
8L 13830-A		Bracket assy (horn)-with spacer-RH-Sparks Withington design-Sea Shell type	1	9L,9H,OL,OH	49-50
8L 13831-A		Bracket assy (horn)-with spacer-LH-Sparks Withington design-Sea Shell type	1	9L,9H,OL,OH	49-50
8M 13831-A		Bracket and spring assy (horn)-Trumpet type horns	2	OL,OH,LL,1H	50-51
		24311-S Bolt (hex-hd)-5/16"-24 x 1/2" -bracket to radiator support	4	9L,9H,OL,OH,LL,1H	49-51
		34806-S7 Lockwasher-5/16"-bracket to radiator support	4	9L,9H,OL,OH	49-50
		34941-S7 Lockwasher (external tooth)-5/16"-bracket to radiator support	4	OL,OH,LL,1H	50-51
51A 13832-A		Horn assy-high pitch-RH-Sparks Withington design	1	9L,9H,OL,OH	49-50
51A 13832-B		Horn assy-high pitch-RE-Auto Lite design	1	9L,9H,OL,OH	49-50
51A 13833-A		Horn assy-low pitch-LH-Sparks Withington design	1	9L,9H,OL,OH	49-50
51A 13833-B		Horn assy-low pitch-LH-Auto Lite design	1	9L,9H,OL,OH	49-50

# Lincoln and Lincoln Cosmopolitan

## CHASSIS PARTS CATALOGUE

PART NUMBER	PART NAME	NO. REQ'D	MODEL	YEAR 19__
<b>Horns—Continued</b>				
	34805-S8 Lockwasher-1/4"-horn to bracket	4	9L,9H,OL,OH	49-50
	34940-S2 Lockwasher (external tooth)- 1/4"-horn to bracket	4	OL,OH,LL,LH	50-51
	33907-S8 Nut (hex-hd)-1/4"-28-horn to bracket	4	9L,9H,OL,OH,LL,LH	49-51
	355073-S8 Screw & lockwasher assy (pan head)-No. 8-32 x 5/16"-horn wire to horn motor	2	9L,9H,OL,OH,LL,LH	49-51
7RA 13853-A	Relay and bracket assy (horn)	1	9L,9H,OL,OH,LL,LH	49-51
	26462-S7 Screw (rd-hd)-No. 8-32 x 5/16"- wiring to relay	3	9L,9H,OL,OH,LL,LH	49-51
	31527-S7 Screw (hex washer head self tapping)-No. 14-14 x 1/2"	2	9L,9H,OL,OH,LL,LH	49-51
A 13987	Bulb (rear compartment courtesy lamp)-3 C.P.-D.C.	2	9H,OH,1H74	49-51
A 13987	Bulb (front compartment courtesy lamp)-3 C.P.-D.C.	2	9L,9H,OL,OH,LL,LH	49-51

# Wiring

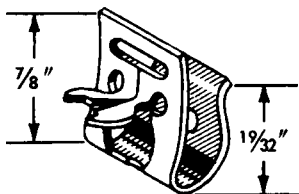

51C-14197

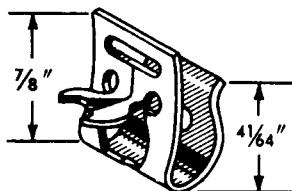

7RA-14197-A

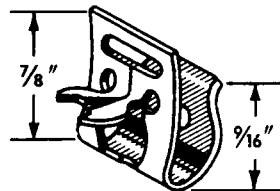

7RA-14197-B

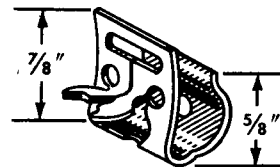

7RC-14197

PL-334

PART NUMBER	C O D E	PART NAME	NO. REQ'D	MODEL	YEAR 19 ____
51C 14197		Clip (cowl wiring to fender apron)	4	9H	49
7RA 14197-A		Clip (fuel line to frame)	5	9L,9H,OL,OH,LL,LH	49-51
7RA 14197-B		Clip (headlamp wire to air deflector)	3	9L,9H,OL,OH	49-50
7RA 14197-B		Clip (roadlamp wire to stone deflector)	4	OL,OH	50
7RA 14197-B		Clip (luggage compartment lamp wire to luggage compartment door inner panel)	1	OL,OH,LL,LH	50-51
7RA 14197-B		Clip (stoplight switch wiring to LH fender apron)	1	OL,OH,LL,LH	50-51
7RA 14197-B		Clip (brake pipe to frame)	3or4	OL,OH,LL,LH	50-51
7RC 14197		Clip (cowl wiring to air deflector)	1	9L,9H	49
7RC 14197		Clip (cowl wiring to RH fender apron)	1	9L,OL	49-50
8C 14197		Clip (instrument wiring to instrument panel)	as reqd	9L,9H	49
8C 14197		Clip (starter solenoid to hydraulic pump solenoid)-to front cross member	2	OH,1H	50-51
8C 14197		Clip (battery to starter relay cable)	1	OL,OH,LL,LH	50-51
51T 14199		Clip (cowl wiring to LH fender apron)	1	9L,9H	49
		358315-S32 Clip (cowl wiring to fender apron)	1	OL,OH	50

# Lincoln and Lincoln Cosmopolitan

## CHASSIS PARTS CATALOGUE

### Wiring—Continued

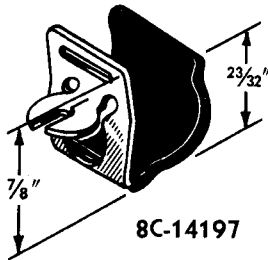

8C-14197

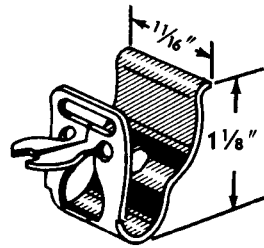

51T-14199

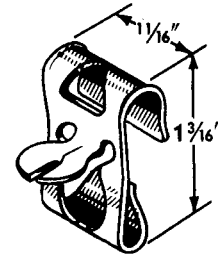

6A-14199

PL-645

PART NUMBER	CLASS	PART NAME	NO. REQ'D	MODEL	YEAR
6A 14199		Clip (headlamp and parking lamp wiring to fender apron)	2	9L,9H,OL,OH	49-50
		351704-S32 Clip (heat indicator crossover to carburetor mount. stud)	1	9L,9H,OL,OH	49-50
		356668-S32 Clip (solenoid wire to window regulator brace R.H. & L.H.)	2	9H76,OH76,1H76	49-51
		356668-S32 Clip (engine compartment lamp to dash flange)	3	9L,OL,LL	49-51
		356668-S32 Clip attach wiring to package tray at lightening holes	2	OH,1H	50-51
8A 14300		Cable assy (battery to starter relay)-13-1/2" long	1	9L,9H	49
OH 14300		Cable assy (battery to starter solenoid)-20-1/2" long	1	OH,1H	50-51
OL 14300		Cable assy (battery to starter solenoid)-22-1/2" long	1	OL,LL	50-51
		34806-S7 Lockwasher-5/16"-cable to starter relay	1	9L,9H,OL,OH,LL,1H	49-51
		33798-S8 Nut (hex)-5/16"-24-cable to starter field terminal	1	9L,9H,OL,OH,LL,1H	49-51
		31527-S7 Screw (hex-hd)-No. 14-10 x 1/2"-cable to air duct	1	9H,OH,1H	49-51
8L 14301		Cable assy (battery to ground)-14-1/2" long	1	9L,9H,OL,OH,LL,1H	49-51
		23017-S16 Bolt (square head)-5/16"-18 x 1-1/4"-cable to battery post	2	9L,9H,OL,OH,LL,1H	49-51
		33797-S16 Nut (hex)-5/16"-18-cable to battery post	2	9L,9H,OL,OH,LL,1H	49-51
7RA 14302		Wiring assy (coil to distributor)-low tension-10" long	1	9L,9H	49
OL 14302		Wire assy (coil to distributor)-low tension-11-3/4" long	1	OL,OH,LL,1H	50-51
		34803-S7 Lockwasher-No. 10	1	OL,OH,LL,1H	50-51
		34805-S8 Lockwasher-1/4"	1	OL,OH,LL,1H	50-51
		34903-S8 Lockwasher (internal tooth)-No. 10-wire to ignition coil	1	OL,OH,LL,1H	50-51
		34079-S7 Nut (hex)-No. 10-32 wiring to distributor and ignition coil	2	OL,OH,LL,1H	50-51
8H 14303		Cable assy (dash to engine)-10" long-ends soldered on	1	9H,OH	49-50
8M 14303		Cable assy (dash to engine)-10" long-ends crimped on	1	9L,OL	49-50
		31527-S7 Screw (hex washer hd self tap.)-No. 14-14 x 1/2"-cable to dash	1	9L,OL	49-50

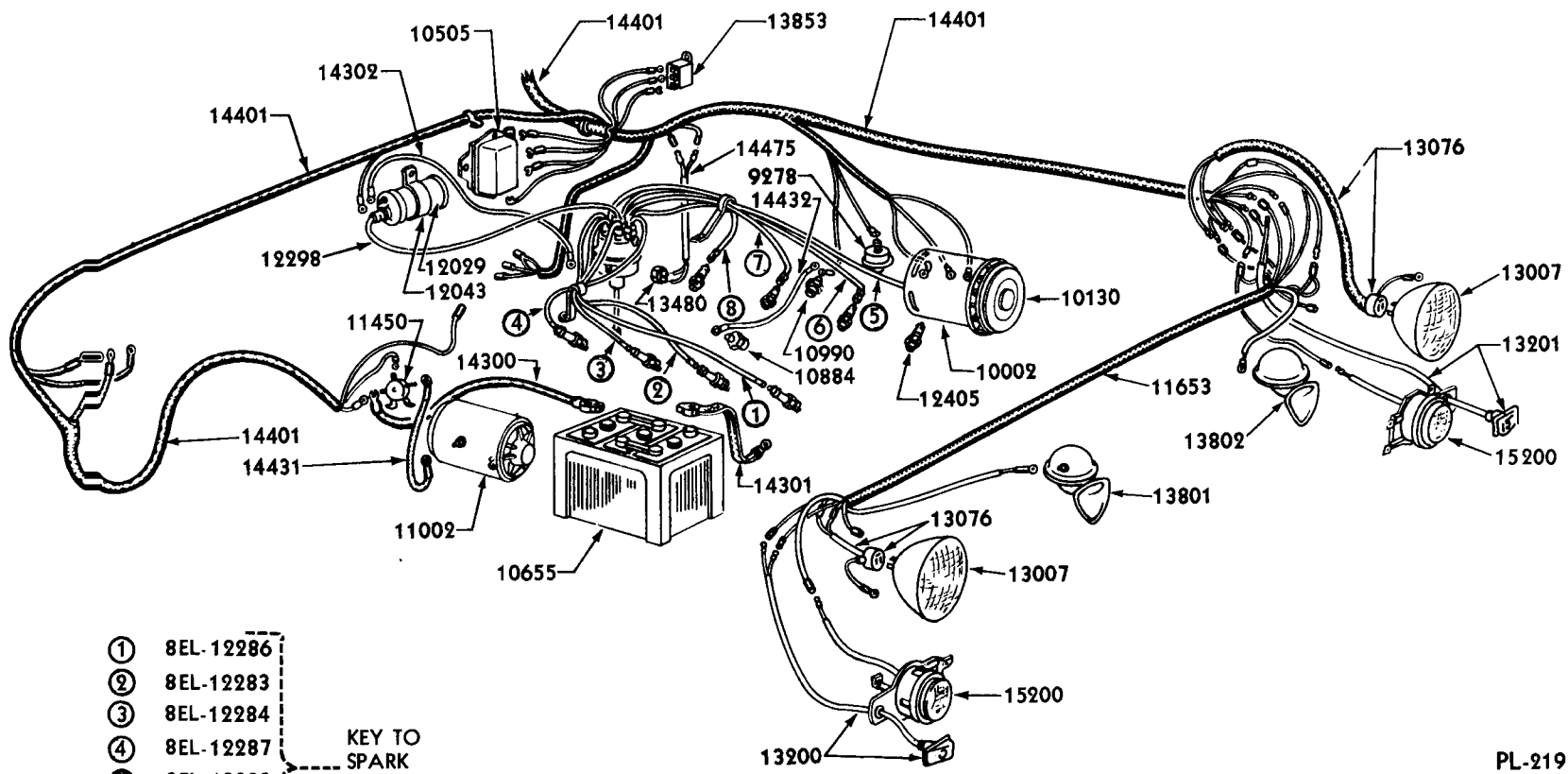

- |   |           |                                  |
|---|-----------|----------------------------------|
| ① | 8EL-12286 | KEY TO<br>SPARK<br>PLUG<br>WIRES |
| ② | 8EL-12283 |                                  |
| ③ | 8EL-12284 |                                  |
| ④ | 8EL-12287 |                                  |
| ⑤ | 8EL-12282 |                                  |
| ⑥ | 8EL-12285 |                                  |
| ⑦ | 8EL-12295 |                                  |
| ⑧ | 8EL-12296 |                                  |

PL-219

**LINCOLN COSMOPOLITAN ENGINE SECTION WIRING (9H)**

Basic numbers only shown on illustration. Order by Part Numbers shown in list of parts.

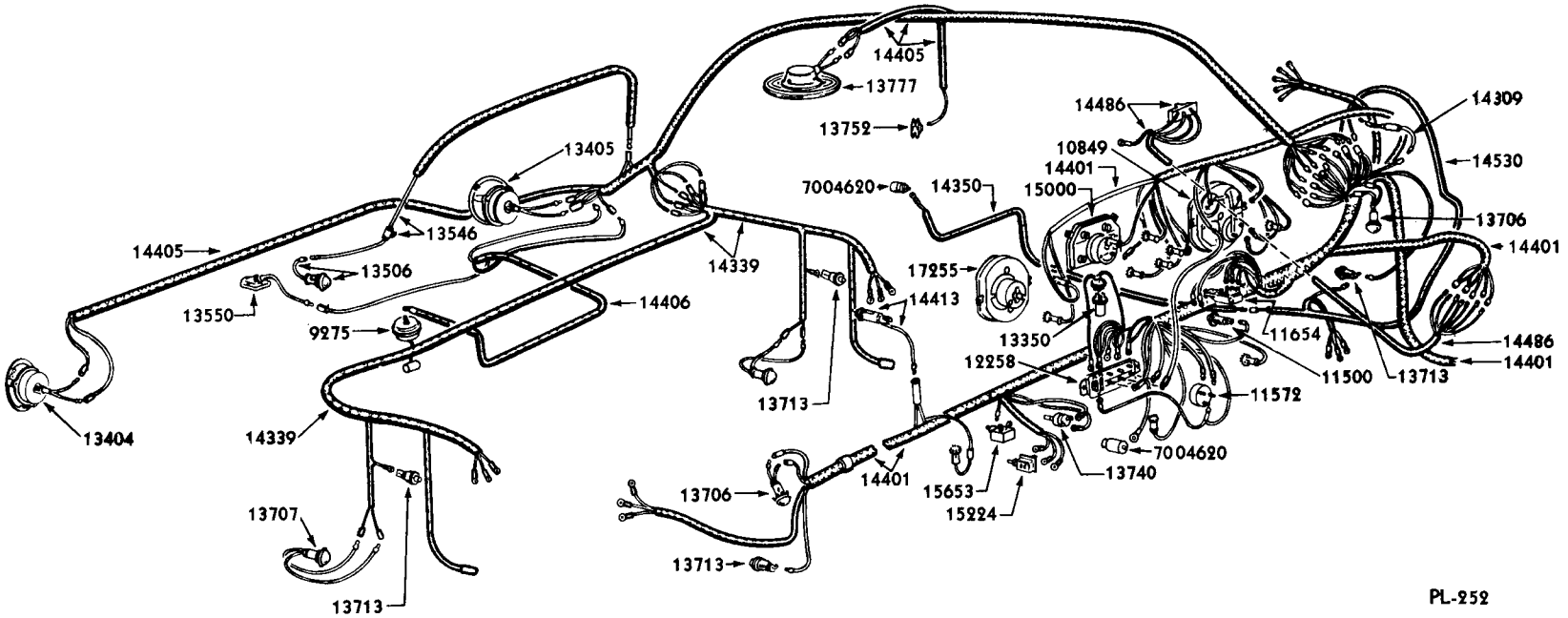

PL-252

**LINCOLN COSMOPOLITAN BODY SECTION WIRING (9H)**

Basic numbers only shown on illustration. Order by Part Numbers shown in list of parts.



*Lincoln and Lincoln Compoletian*

CHASSIS PARTS CATALOGUE

Wiring—Continued

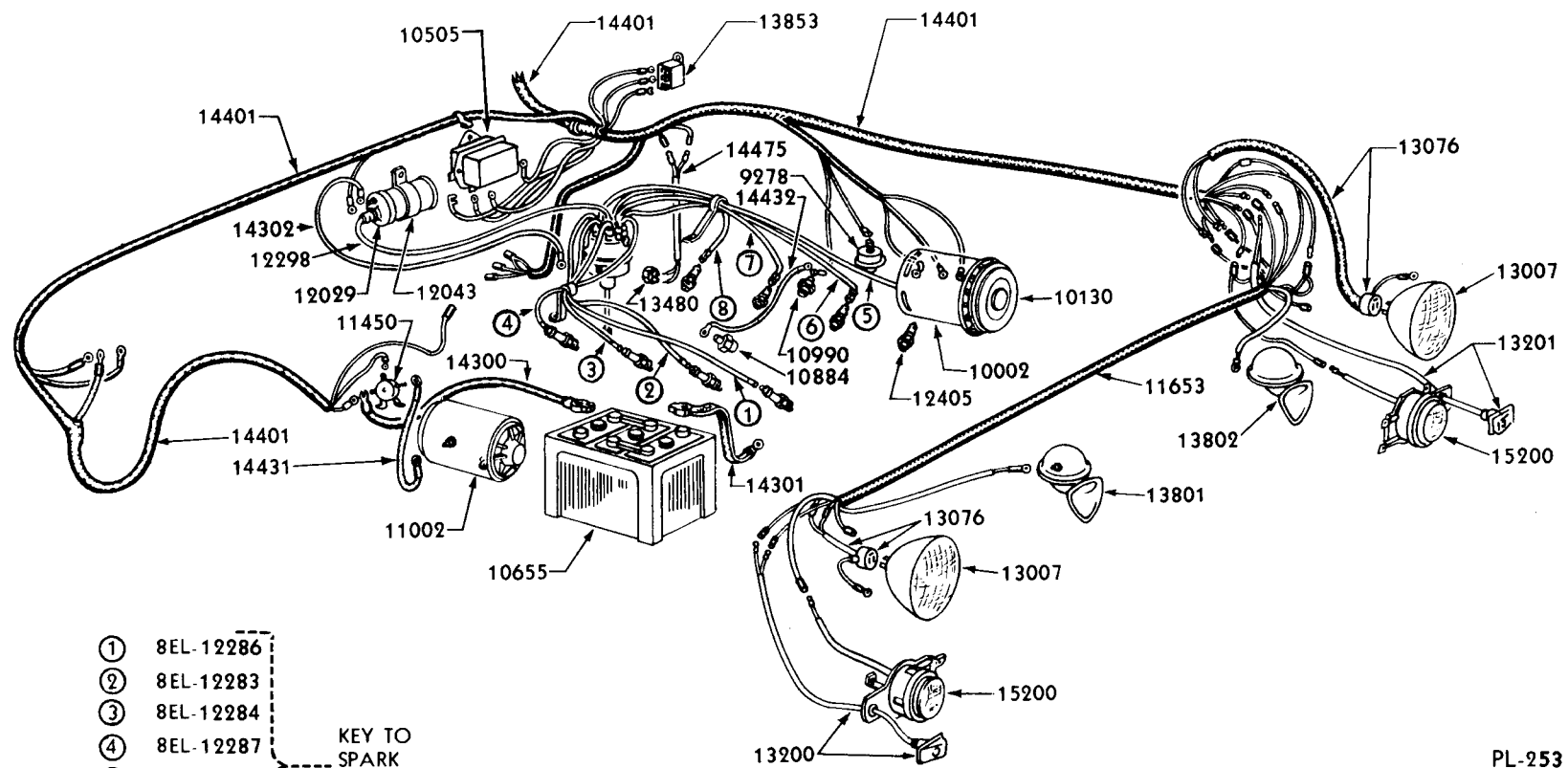

- ① 8EL-12286
  - ② 8EL-12283
  - ③ 8EL-12284
  - ④ 8EL-12287
  - ⑤ 8EL-12282
  - ⑥ 8EL-12285
  - ⑦ 8EL-12295
  - ⑧ 8EL-12296
- KEY TO SPARK PLUG WIRES

PL-253

**LINCOLN ENGINE SECTION WIRING (9L)**  
 Basic numbers only shown on illustration. Order by Part Numbers shown in list of parts.

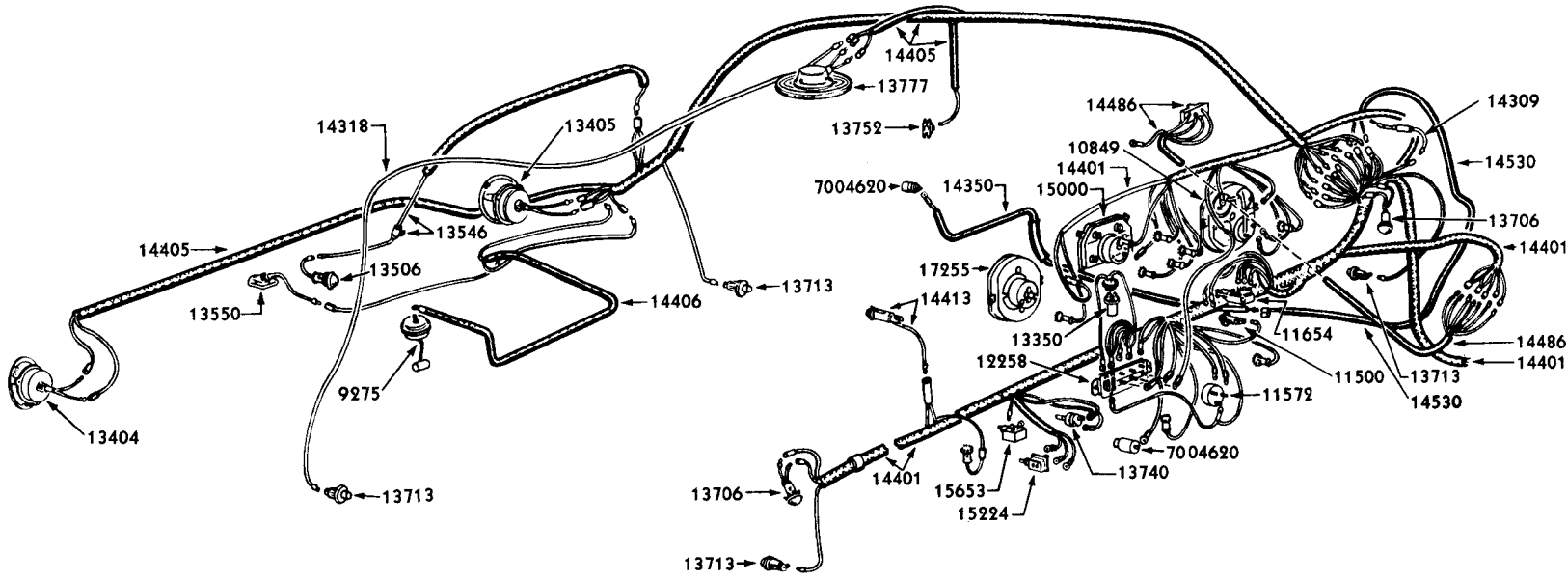

PL-254

**LINCOLN BODY SECTION WIRING (9L)**

Basic numbers only shown on illustration. Order by Part Numbers shown in list of parts.

*Lincoln and Lincoln Cosmopolitan*

CHASSIS PARTS CATALOGUE

Wiring—Continued

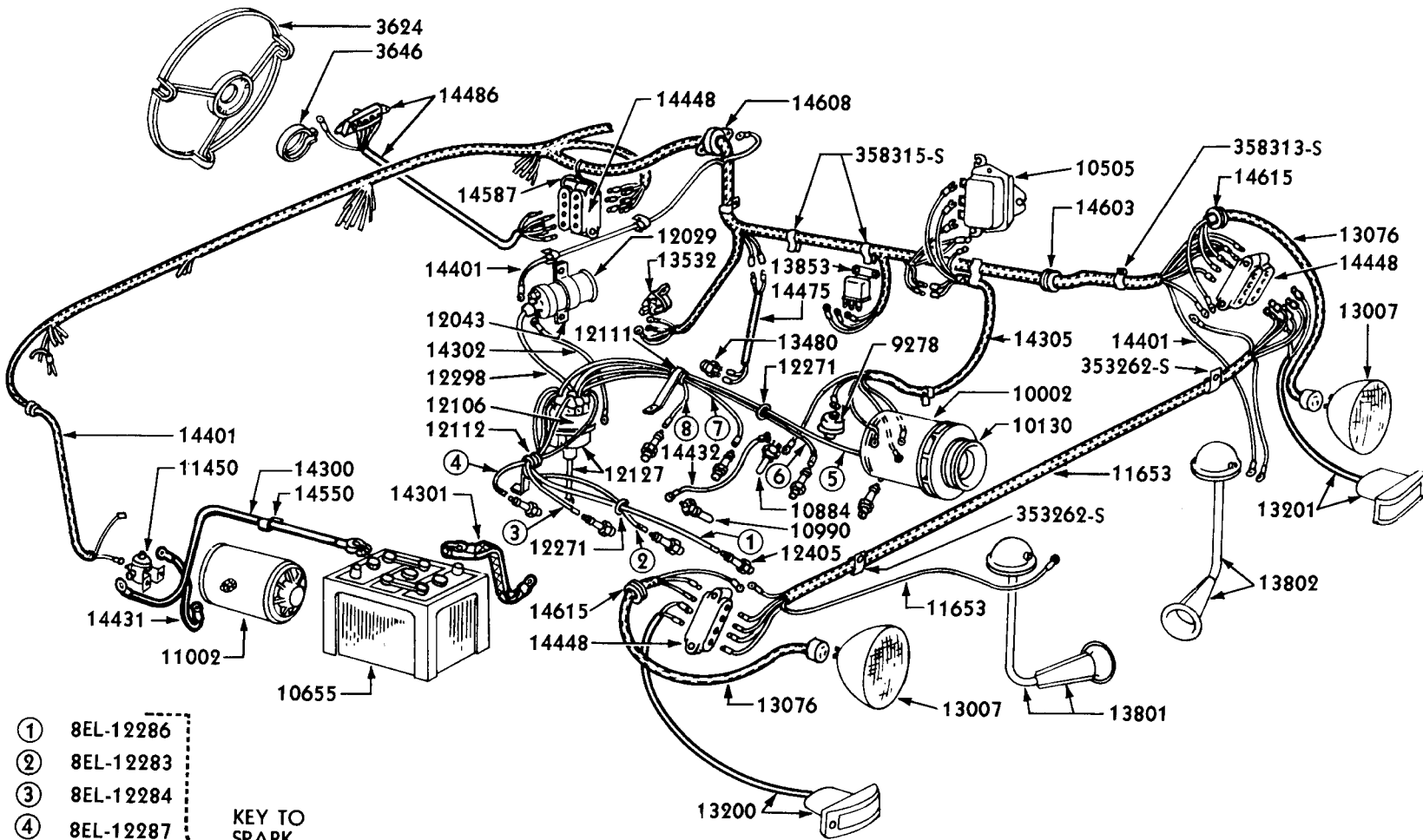

- ① 8EL-12286
- ② 8EL-12283
- ③ 8EL-12284
- ④ 8EL-12287
- ⑤ 8EL-12282
- ⑥ 8EL-12285
- ⑦ 8EL-12295
- ⑧ 8EL-12296

KEY TO  
SPARK  
PLUG  
WIRES

PL-437

**LINCOLN COSMOPOLITAN ENGINE SECTION WIRING (OH)**

Basic numbers only shown on illustration. Order by Part Numbers shown in list of parts.

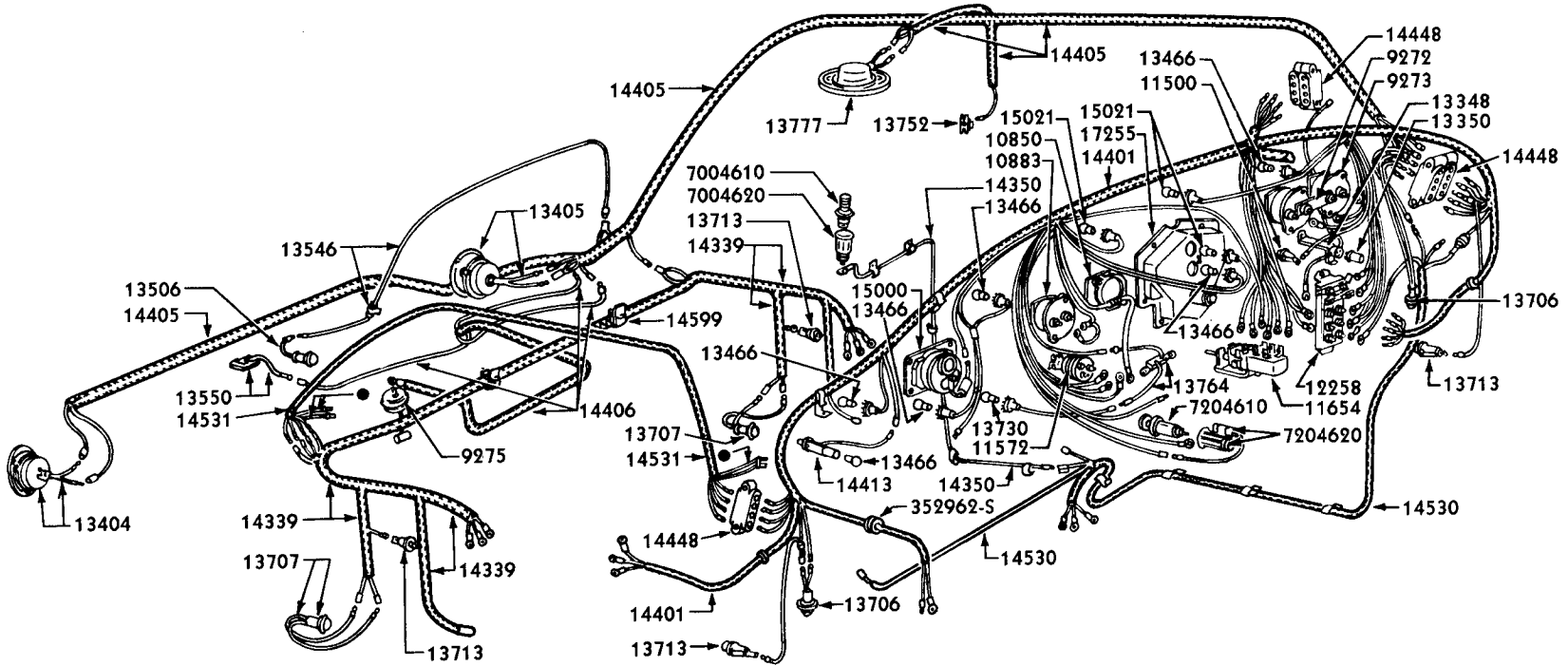

● REAR SEAT SPEAKER WIRING

PL-423

**LINCOLN COSMOPOLITAN BODY SECTION WIRING (OH)**

Basic numbers only shown on illustration. Order by Part Numbers shown in list of parts.

Wiring—Continued

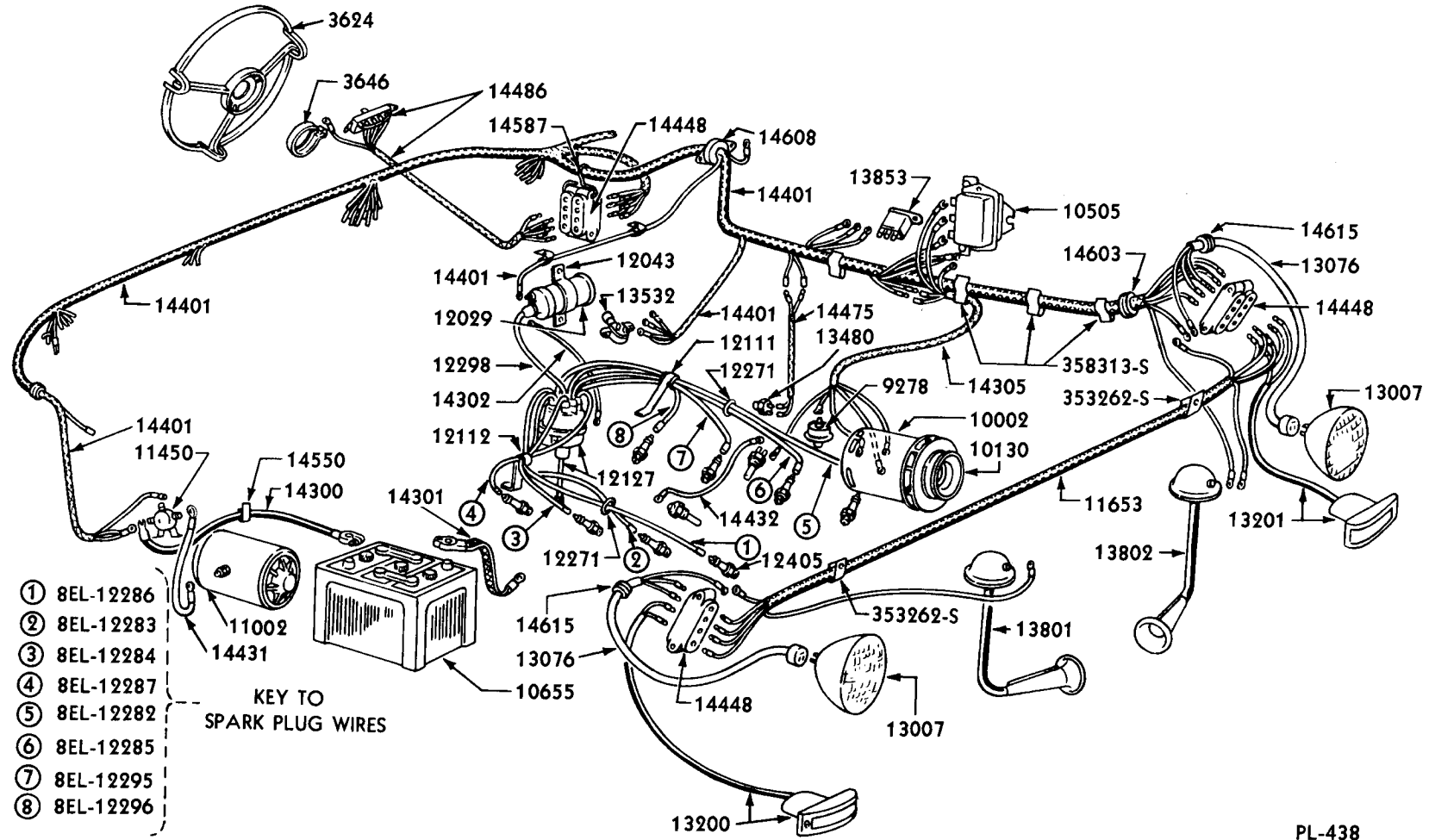

- ① 8EL-12286
- ② 8EL-12283
- ③ 8EL-12284
- ④ 8EL-12287
- ⑤ 8EL-12282
- ⑥ 8EL-12285
- ⑦ 8EL-12295
- ⑧ 8EL-12296

KEY TO  
 SPARK PLUG WIRES

**LINCOLN ENGINE SECTION WIRING (OL)**

Basic numbers only shown on illustration. Order by Part Numbers shown in list of parts.

PL-438

Wiring—Continued

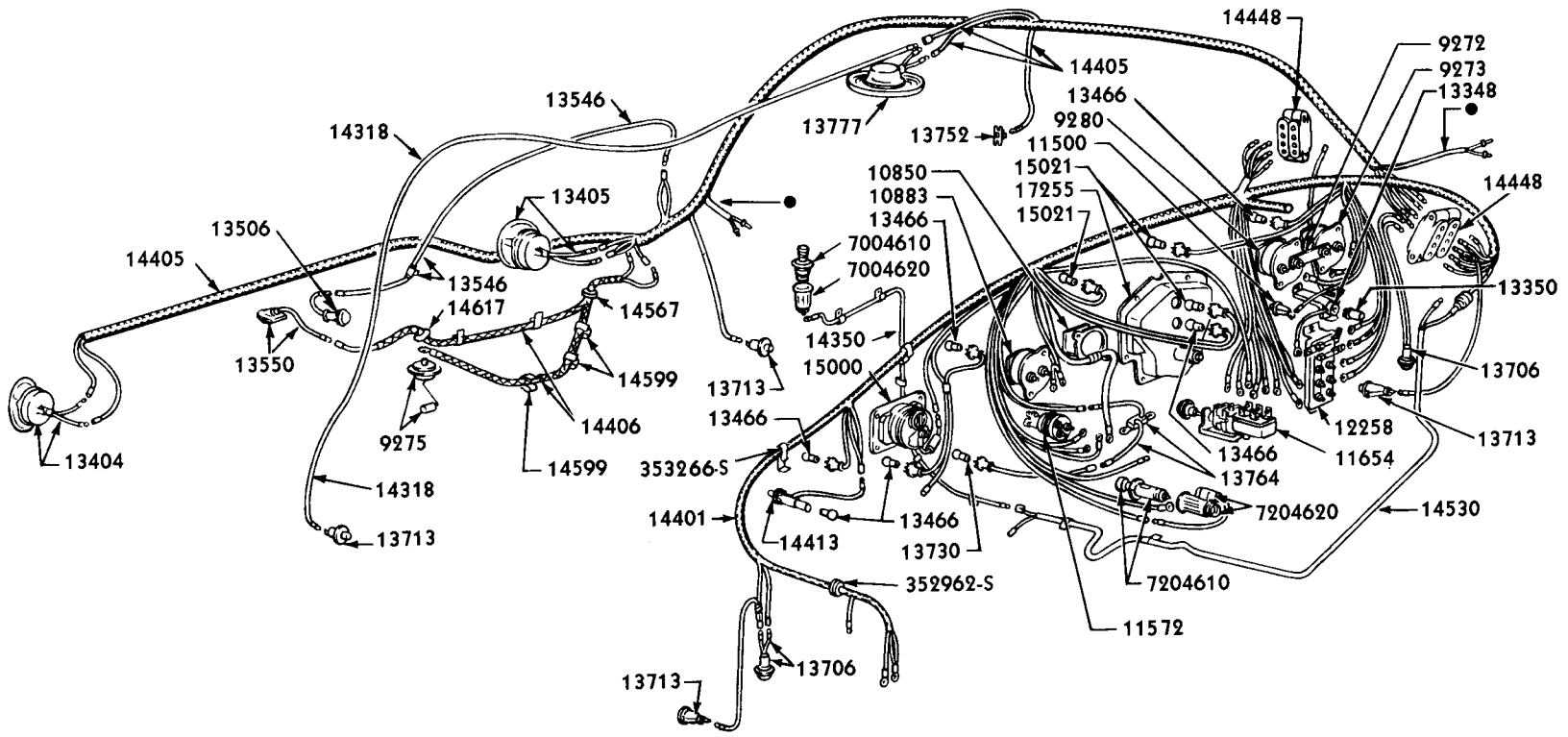

● REAR SEAT SPEAKER WIRES

PL-422

**LINCOLN BODY SECTION WIRING (OL)**

Basic numbers only shown on illustration. Order by Part Numbers shown in list of parts.

# Lincoln and Lincoln Cosmopolitan

## CHASSIS PARTS CATALOGUE

PART NUMBER	PART NAME	NO. REQ'D	MODEL	YEAR 19__
<b>Wiring—Continued</b>				
8H 14305	Wiring assy (generator to voltage regulator)-use with 60 amp. generator	1	9H	49
8M 14305	Wiring assy (generator to voltage regulator)-use with 60 amp. generator	1	9L	49
OH 14305	Wiring assy (generator to voltage regulator)-used with 60 amp. generator	1	OH	50
OL 14305-A	Wiring assy (regulator to generator)-used with 35-40 amp. generator	1	OL,OH,LL,LH	50-51
OL 14305-B	Wiring assy (generator to voltage regulator)-used with 60 amp. generator	1	OL	50
LL 14305-A	Wiring assy (generator to voltage regulator)-used with 32-40 amp. generator-ground wire outlet 3-1/2" from loom end	1	LL,LH	51
	356668-S32 Clip (regulator wiring to cowl flange)	4	OL,LL	50-51
	356628-S Clip (wiring to water pump)	2	OL,OH,LL,LH	50-51
	34802-S7 Lockwasher-No. 8-wiring to oil pressure gage	1	OL,OH,LL,LH	50-51
	34803-S7 Lockwasher-No. 10-wiring to generator	2	OL,OH,LL,LH	50-51
	34805-S8 Lockwasher-1/4"-wiring to generator	1	OL,OH,LL,LH	50-51
	34079-S7 Nut (hex)-No. 10-32-wiring to generator	2	OL,OH,LL,LH	50-51
	34081-S7 Nut (hex)-1/4"-20-wiring to generator	1	OL,OH,LL,LH	50-51
	26457-S7 Screw (round head)-No. 8-32 x 1/4"-wiring to oil pressure gage	1	OL,OH,LL,LH	50-51
8L 14309	Jumper wire assy (heater switch)-19" long	1	9L,9H	49
OH 14309-B	Wire assy (heater switch to blower motor)-75-1/4" long	1	OH	50
OH 14309-C	Wire assy (heater switch to resistor)-75" long	1	OH	50
OH 14309-D	Wire assy (heater switch resistor)-6" long	1	OH	50
OL 14309-A	Wire assy (heater switch to blower motor)-60-1/4" long	1	OL	50
OL 14309-B	Wire assy (heater switch to resistor)-39" long	1	OL	50
OL 14309-C	Wire assy (heater switch resistor)-16" long	1	OL	50
OM 14309-A	Wire and fuse assy (ignition switch to heater switch)-8" long	1	OL,OH,LL,LH	50-51
8M 14318	Wire assy (lamp to rear RH door switch)-84-1/4" long	1	9L74,OL74,LL74	49-51
8M 14332-B	Wire assy (top control switch to solenoid)-11" long	1	9L76,9H76	49
8L 14334	Wiring assy (body wiring to dome lamp)-71" long	1	9L76,9H76,OH76,LH76	49-51
	353247-SA Grommet (rubber)-13/64" x 19/64" x 3/16"-wiring thru roof bow	1	9L76,9H76,OH76,LH76	49-51
8L 14336-A	Wiring assy (cigar lighter rear)-89" long	1	9L72-74	49
8L 14336-B	Wiring assy (cigar lighter rear)-67" long	1	9L72-74,OL72-74,LL72-74	49-51

# Lincoln and Lincoln Cosmopolitan

## CHASSIS PARTS CATALOGUE

PART NUMBER	PART NAME	NO. REQ'D	MODEL	YEAR
<b>Wiring—Continued</b>				
8H 14339-A	Wiring assy (rear window switches to body harness)- 12 terminals-braided loom approx. 143-1/2" long	1	9H72	49
8H 14339-C	Wiring assy (rear window switches to body harness)- 19 terminals-braided loom approx. 138" long	1	9H73-74	49
8H 14339-D	Wiring assy (rear window switches to body harness)- 16 terminals-braided loom approx. 134-3/4" long	1	9H76,OH76,1H76	49-51
OH 14339-A	Wiring assy (rear window switches to body harness)- 12 terminals-braided loom approx. 144" long	1	OH72,1H72	50-51
OH 14339-B	Wiring assy (rear window switches to body harness)	1	OH74	50
1H 14339-A	Wiring assy (rear window switches to body harness)	1	1H74	51
8L 14339	Wiring assy (rear window switches to body harness)- 12 terminals-braided loom approx. 152" long	1	9L74	49
OM 14339	Wiring assy (rear window switches to body harness)	1	OL74,1L74	50-51
8M 14339-A	Wiring assy (rear window switches to body harness)- 16 terminals-braided loom approx. 117-3/4" long	1	9L76,9H76,OH76,1H76	49-51
	356668-S32 Clip (rear window switch wiring to rear seat back support)	4	9H74,OH74,1H74	49-51
	356668-S32 Clip (rear window switch wiring to wheel well flange)	1	9L74,9H76,OL74,OH74,1L74,1H74	49-51
	356668-S32 Clip (rear window switch wiring to window regulator brace L.H. side)	1	9H76,OH76,1H76	49-51
	356668-S32 Clip (rear window switch wiring to package tray flange)	1	OL74,1L74	50-51
	356668-S32 Clip (rear window switch wiring to cylinder bracket and inner door panel)	2	9L74,OL74,1L74	49-51
	356687-S32 Clip (wiring to quarter panel)	6	OH72,1H72	50-51
	358313-S32 Clip (wiring)-wiring to seat strainer	2	OH,1H,except 76	50-51
	34801-S7 Lockwasher-No. 6-wiring to window and dome lamp switches	6or8	9H,OH,1H	49-51
	34051-S7 Nut (hex)-No. 6-32-wiring to window and dome lamp switches	6or8	9H,OH,1H	49-51
8L 14350-E	Wiring assy (cigar lighter)-front seat back-right side-105" long	1	9L72-76,9H72-76,OL72,OH72-76,1L72,1H72-76	49-51
8L 14350-F	Wiring assy (cigar lighter)-front seat back-40" long	1	9L72-76,9H72-76,OL72,OH72-76,1L72,1H72-76	49-51
8L 14350-G	Wiring and metal tube assy (cigar lighter)-front seat back-63-1/2" long	1	9L74,9H73,OL74	49-50
1H 14350-C	Wiring assy (cigar lighter)-front seat back-79-1/2" long	1	1H74	51
1L 14350-B	Wiring assy (cigar lighter)-front seat back-63-1/2" long	1	1L74	51
OL 14369	Wire assy (left roadlamp to right lamp)-37-1/2" long	1	OL,OH,1L,1H	50-51
8L 14381	Wiring assy (overdrive harness to ignition coil)- distributor side-3-1/2" long	1	9L	49
	353262-S Clip (overdrive wire at carb. base stud)	1	9L	49



# Lincoln and Lincoln Cosmopolitan

## CHASSIS PARTS CATALOGUE

PART NUMBER	PART NAME	NO. REQ'D	MODEL	YEAR
<b>Wiring-Continued</b>				
8H 14382	Wiring assy (transmission overdrive solenoid to relay)	1	9H,OH	49-50
8M 14382	Wiring assy (transmission overdrive solenoid to relay)	1	9L,OL	49-50
1H 14382-A	Wiring assy (transmission overdrive solenoid to relay)	1	1H	51
1L 14382-B	Wiring assy (transmission overdrive solenoid to relay)	1	1L	51
	353262-S Clip (overdrive wire to relay mounting screw)	1	9L,9H,OL,OH,1L,1H	49-51
8L 14396	Wiring assy (ignition circuit to overdrive relay)-11-1/2" long	1	9L,9H,OL,OH,1L,1H	49-51
8H 14401-A	Wiring assy (instrument panel and dash panel)-with spade terminal to regulator ground	1	9H	49
8H 14401-B	Wiring assy (instrument panel and dash panel)-with eyelet terminal to regulator ground	1	9H	49
OH 14401-A	Wiring assy (instrument panel and dash panel)	1	OH	50
OH 14401-C	Wiring assy (instrument panel and dash panel)	1	OH	50
1H 14401-A	Wiring assy (instrument panel and dash panel)	1	1H	51
1H 14401-B	Wiring assy (instrument panel and dash panel)-used with 60 amp. heavy duty generator	1	1H	51
8L 14401-A	Wiring assy (instrument panel and dash panel)-with voltage regulator ground terminal to ground wire-not used with hydraulic system	1	9L except 76	49
8L 14401-B	Wiring assy (instrument panel to dash panel)-with spade terminal to regulator ground-used with hydraulic system	1	9L	49
8L 14401-C	Wiring assy (instrument panel and dash panel)-without voltage regulator ground terminal to ground wire-not used with hydraulic system	1	9L except 76	49
8L 14401-D	Wiring assy (instrument panel and dash panel)-with eyelet terminal to regulator ground-used with hydraulic system	1	9L	49
OL 14401-A	Wiring assy (instrument panel and dash panel)-not used with hydraulic system	1	OL	50
OL 14401-C	Wiring assy (instrument panel and dash panel)-used with hydraulic system	1	OL	50
OL 14401-E	Wiring assy (instrument panel and dash panel)-not used with hydraulic system	1	OL	50
OL 14401-G	Wiring assy (instrument panel and dash panel)-used with hydraulic system	1	OL	50
1L 14401-A	Wiring assy (instrument panel and dash panel)-not used with hydraulic system	1	1L	51
1L 14401-B	Wiring assy (instrument panel and dash panel)-not used with hydraulic system-used with 60 amp. heavy duty generator	1	1L	51
1L 14401-C	Wiring assy (instrument panel and dash panel)-used with hydraulic system	1	1L	51
1L 14401-D	Wiring assy (instrument panel and dash panel)-used with hydraulic system and 60 amp. heavy duty generator	1	1L	51
	353266-SA Clip (wiring)-dash and instrument wire to glove compartment	1	OL,OH	50

+ Used with HYDRA-MATIC transmission

++ Not used with HYDRA-MATIC transmission

# Lincoln and Lincoln Cosmopolitan

## CHASSIS PARTS CATALOGUE

PART NUMBER	PART NAME	NO. REQ'D	MODEL	YEAR 19
<b>Wiring—Continued</b>				
	356668-S32	Clip (instrument panel wiring to dash panel flange)	2 OL,OH,1H	50-51
	358313-S32	Clip (wiring)-cowl wiring to LH fender apron and air deflector	3 OL,OH,1L,1H	50-51
	358313-S32	Clip (wiring)-cowl wiring to floor pan	1 OL,OH,1L,1H	50-51
	358315-S32	Clip (attach instrument panel wiring to dash panel)	1 OL,1L	50-51
	358315-S32	Clip (attach instrument panel wiring to L.H. fender apron)	2 OL,OH,1L,1H	50-51
	34803-S7	Lockwasher-No. 10	5 OL,OH,1L,1H	50-51
	34801-S7	Lockwasher-No. 6-wiring to window and seat switches	12 9H,OH,1H	49-51
	34802-S7	Lockwasher-No. 8-wiring to heat indicator bulb	1 9L,9H,OL,OH,1L,1H	49-51
	34802-S7	Lockwasher-No. 8-wiring to cigar lighter	1 9L,9H,OL,OH,1L,1H	49-51
	351230-S7	Lockwasher-No. 8-wiring to horn relay and bracket	3 9L,9H,OL,OH,1L,1H	49-51
	34051-S7	Nut (hex)-No. 6-32-wiring to window and seat switches	12 9H,OH,1H	49-51
	34051-S7	Nut (hex)-No. 6-32-wiring to cigar lighter	1 9L,9H,OL,OH,1L,1H	49-51
	356216-S7	Retainer (terminal)-wiring to terminal	3 OL,OH,1L,1H	50-51
	27687-S	Screw (rd-hd)-No. 8-32 x 3/16"-wiring to heat indicator bulb	1 9L,9H,OL,OH,1L,1H	49-51
	42802-S8	Screw and washer (pan head)-No. 10-32 x 3/8"-wiring to regulator terminals	3 9L,9H,OL,OH,1L,1H	49-51
8L 14402	Wire and socket assy (transmission gear shift indicator lamp)	1	9L,9H,OL,OH,1L,1H	49-51
8H 14405-A	Wiring assy (rear lamps)-22 terminals-braided loom approximately 214-3/4" long	1	9H72	49
8H 14405-B	Wiring assy (rear lamps)-23 terminals-braided loom approximately 216-1/4" long	1	9H73-74	49
8H 14405-C	Wiring assy (rear lamps)-22 terminals-braided loom approximately 261" long-top control switch feed wire 64-1/2" long	1	9H76	49
OH 14405-A	Wiring assy (rear lamps)-14 terminals-braided loom approximately 215-1/2" long	1	OH72,1H72	50-51
OH 14405-B	Wiring assy (rear lamps)-15 terminals-braided loom approximately 217-1/2" long	1	OH74	50
OH 14405-C	Wiring assy (rear lamps)-23 terminals-braided loom approximately 307-1/2" long	1	OH76,1H76	50-51
1H 14405-A	Wiring assy (rear lamps)-15 terminals-approximately 217-1/2" long	1	1H74	51
8L 14405-C	Wiring assy (rear lamps)-23 terminals-braided loom approximately 190-1/4" long	1	9L74	49
8M 14405-A	Wiring assy (rear lamps)-14 terminals-braided loom approximately 203" long	1	9L72	49
8M 14405-B	Wiring assy (rear lamps)-15 terminals-braided loom approximately 203-1/4" long	1	9L74	49

† Used with HYDRA-MATIC transmission

# Lincoln and Lincoln Cosmopolitan

## CHASSIS PARTS CATALOGUE

PART NUMBER	CLASS	PART NAME	NO. REQ'D	MODEL	YEAR 19__
<b>Wiring-Continued</b>					
8M 14405-C		Wiring assy (rear lamps)-22 terminals-braided loom approximately 261" long-top control switch feed wire 17-1/2" long	1	9L76	49
OM 14405-A		Wiring assy (rear lamps)-18 terminals-braided loom approximately 211-1/2" long	1	OL72	50
OM 14405-B		Wiring assy (rear lamps)-19 terminals-braided loom approximately 212" long	1	OL74	50
1M 14405-A		Wiring assy (rear lamps)-18 terminals-approximately 211-1/2" long	1	1L72	51
1M 14405-B		Wiring assy (rear lamps)-19 terminals-approximately 212" long	1	1L74	51
		353262-S Clip (wire)-wiring to tail lamp mounting stud	2	OL,OH,1L,1H	50-51
		356668-S32 Clip (rear lamp wiring to rear wheel well flange)	2	OL,OH76,1L,1H76	50-51
		356668-S32 Clip (rear lamp wiring to rear quarter panel)	1	9H,OH,1H	49-51
		356668-S32 Clip (rear lamp wiring to package tray)	2	9L,OL,1L	49-51
		356668-S32 Clip (rear lamp wiring to cowl flange)	4	9L,OL,1L	49-51
		358313-S32 Clip (wiring)-wiring to floor pan	4	OH76,1H76	50-51
		34937-S7 Lockwasher-No. 6-wiring to top control	2	9H76,OH76,1H76	49-51
		34051-S7 Nut (hex)-No. 6-32-wiring to top control	1	9H76,OH76,1H76	49-51
		26466-S6 Screw (round head)-wiring to top control	1	9H76,OH76,1H76	49-51
8M 14406-A		Wiring assy (fuel gauge tank unit)-62" long	1	9L,9H	49
OM 14406		Wiring assy (fuel gauge tank unit)-60-1/2" long	1	9L,9H,OL,OH,1L,1H	49-51
		356640-S2 Clip (wire)-wiring to stone deflector	1	9L,9H,OL,OH,1L,1H	49-51
		34802-S7 Lockwasher-No. 8-wiring to fuel gage tank unit	1	9L,9H,OL,OH,1L,1H	49-51
		26457-S7 Screw (round head)-No. 8-32 x 1/4"-wiring to fuel gage tank unit	1	9L,9H,OL,OH,1L,1H	49-51
8L 14413		Switch, socket & wiring assy (glove compt. lamp)-length of switch and socket 1-7/8"	1	9L,9H,OL,OH	49-50
OM 14413-A		Switch, socket & wiring assy (glove compartment lamp)-length of switch and socket 1-31/64"	1	OL,OH,1L,1H	50-51
7RC 14431	NS	Cable assy (relay to starter)-24-1/2" long-use 8H-14431 for service	1	OH,1H	50-51
8H 14431		Cable assy (relay to starter)-28-1/2" long	1	9L,9H,OH,1H	49-51
OL 14431		Cable assy (relay to starter)-18-1/2" long	1	OL,1L	50-51
		34806-S7 Lockwasher-5/16"-cable to starter field terminal	1	9L,9H,OL,OH,1L,1H	49-51
		34806-S7 Lockwasher-5/16"-cable to starter relay	1	9L,9H,OL,OH,1L,1H	49-51
		33798-S8 Nut (hex)-5/16"-24-cable to starter field terminal	1	9L,9H,OL,OH,1L,1H	49-51

# Lincoln and Lincoln Cosmopolitan

## CHASSIS PARTS CATALOGUE

PART NUMBER	PART NAME	NO. REQ'D	MODEL	YEAR 19__
<b>Wiring—Continued</b>				
7EH 14432	Wire assy (engine excessive heat indicator)-19-1/2" long-red with white tracer	1	9L,9H	49
OL 14432	Wire assy (engine excessive heat indicator)-19-1/2" long-black wire	1	OL,OH,1L,1H	50-51
	356640-S2 Clip (engine excessive heat indicator wire to carb. base)	1	9L,9H,OL,OH,1L,1H	49-51
	34802-S7 Lockwasher-No. 8-wire to heat indicator bulb	1	9L,9H,OL,OH,1L,1H	49-51
	26457-S7 Screw (round head)-No. 8-32 x 1/4"-wiring to heat indicator bulb	1	9L,9H,OL,OH,1L,1H	49-51
	27687-S Screw (round head)-No. 8-32 x 3/16"-wire to heat indicator bulb	1	9L,9H,OL,OH,1L,1H	49-51
OL 14445-A	Wiring assy (headlamp)-R.H. to L.H.-12 terminals-approximately 41" long	1	OL,OH	50
OL 14445-B	Wiring assy (headlamp)-R.H. to L.H.-12 terminals-approximately 43" long	1	OL,OH,1L,1H	50-51
	353262-S Clip (headlamp wire to hood)	3	OL,OH,1L,1H	50-51
OA 14448-A	Block assy (elect. wiring junction)-4 singles connector type	1	OL,OH,1L,1H	50-51
OH 14448	Block assy (elect. wiring junction)-6 singles-1 doubles connector type	1	OL,OH,1L,1H	50-51
OL 14448	Block assy (elect. wiring junction)-2 singles-3 doubles connector type	1	OL,OH,1L,1H	50-51
OM 14448	Block assy (elect. wiring junction)-4 singles-2 doubles connector type	1	OL,OH,1L,1H	50-51
	40969-S8 Screw (hex washer head self tapping)-No. 8-32 x 1"-junction block to R.H. air deflector	2	OL,OH,1L,1H	50-51
	40969-S8 Screw (hex washer head self tapping)-No. 8-32 x 1"-junction block to R.H. body pillar	2	OH,1H	50-51
	40995-S8 Screw (hex washer head self tapping)-No. 8-32 x 1-1/2"-junction block to L.H. air deflector	2	OL,OH,1L,1H	50-51
	40995-S8 Screw (hex washer head self tapping)-No. 8-32 x 1-1/2"-junction block to L.H. body pillar	2	OH,1H	50-51
	40995-S8 Screw (hex washer head self tapping)-No. 8-32 x 1-1/2"-junction block to L.H. cowl side	2	OL,1L	50-51
11A 14452	Terminal (battery cable)	3or4	9L,9H,OL,OH,1L,1H	49-51
B 14455	Sleeve (wire terminal insulating)	as reqd	9L,9H,OL,OH,1L,1H	49-51
B 14462	Terminal eyelet (end type)	as reqd	9L,9H,OL,OH,1L,1H	49-51

# Lincoln and Lincoln Cosmopolitan

## CHASSIS PARTS CATALOGUE

PART NUMBER	PART NAME	NO. REQ'D	MODEL	YEAR
<b>Wiring—Continued</b>				
B 14463	Terminal (wire)-eyelet type	as reqd	9L, 9H, 0L, 0H, 1L, 1H	49-51
8H 14475	Wiring assy (stop light switch)-20" long	1	9L, 9H, 0L, 0H, 1L, 1H	49-51
+8L 14476	Wiring assy (starter switch to trans. lock switch)-50" long	1	9L, 9H	49
+0L 14476	Wiring assy (starter switch to transmission lock switch)-40" long	1	0L, 0H, 1L, 1H	50-51
8L 14486	Switch and wiring assy (turn signal)	1	9L, 9H	49
0L 14486	Switch and wiring assy (turn signal)	1	0L, 0H	50
1M 14486-A	Switch and wiring assy (turn signal)	1	1L, 1H	51
	34901-S7 Lockwasher-No. 6-horn wire to horn support	1	9L, 9H, 0L, 0H, 1L, 1H	49-51
	33170-S8 Screw (pan head self tapping)-No. 10-16 x 1/4"-switch to steering wheel flange	2	9L, 9H, 0L, 0H, 1L, 1H	49-51
	33181-S7 Screw (pan-hd)-No. 6-20 x 1/2"-horn wire to horn support	1	9L, 9H, 0L, 0H, 1L, 1H	49-51
B 14487	Connector (wire and sleeve)	as reqd	9L, 9H, 0L, 0H, 1L, 1H	49-51
11A 14487	Connector and insulator assy (terminal)	as reqd	9L, 9H, 0L, 0H, 1L, 1H	49-51
59A 14487	Connector assy (terminal)-4 way	as reqd	9L, 9H, 0L, 0H, 1L, 1H	49-51
8L 14506	Cable assy (starter solenoid to pump solenoid)-80" long	1	9L, 9H, 0L, 0H, 1L, 1H	49-51
8H 14508	Wiring assy (window regulator switch to solenoid)-29" long	2	9L, 9H, 0L, 0H	49-50
0H 14508	Wiring assy (window regulator switch to solenoid)	2	0L, 0H, 1L, 1H	50-51
51A 14519	Strap (hydraulic pump to ground)-4" long	1	9L76, 9H, 0H	49-50
8H 14519	Strap (hydraulic pump motor ground)-5-3/8" long	1	9L, 9H, 0L, 1L	49-51
0H 14519	Strap (hydraulic pump motor ground)-16-3/4" long	1	0H, 1H	50-51
B 14526	NS Fuse-20 amp.-serviced in B-14527 Kit	as reqd	9L, 9H, 0L, 0H, 1L, 1H	49-51
51A 14526-B	NS Fuse-3 amp.-serviced in APA-14527-B Kit	as reqd	9L, 9H, 0L, 0H, 1L, 1H	49-51
5EH 14526	Fuse-30 amp.	as reqd	9L, 9H, 0L, 0H, 1L, 1H	49-51
7RA 14526-A	Circuit breaker assy (hydraulic system)-15 amp.	1 or 2	9L, 9H, 0L, 0H, 1L, 1H	49-51
8A 14526	NS Fuse-14 amp.-serviced in APA-14527-D Kit	as reqd	9L, 9H, 0L, 0H, 1L, 1H	49-51
B 14527	Kit (fuse)-20 amp.-consists of the following (5) B-14526 Fuse	as reqd	9L, 9H, 0L, 0H, 1L, 1H	49-51
APA 14527-B	Kit (fuse)-3 amp.-consists of the following (5) 51A-14526-B Fuse	as reqd	9L, 9H, 0L, 0H, 1L, 1H	49-51
APA 14527-D	Kit (fuse)-14 amp.-consists of the following (5) 8A-14526 Fuse	as reqd	9L, 9H, 0L, 0H, 1L, 1H	49-51

+ Used with HYDRA-MATIC transmission

# Lincoln and Lincoln Cosmopolitan

## CHASSIS PARTS CATALOGUE

PART NUMBER	PART NAME	NO. REQ'D	MODEL	YEAR 19__
-------------	-----------	-----------	-------	--------------

### Wiring—Continued

8L 14530-A	Wiring assy (hydraulic seat regulator)-10 terminals-approximately 81" long	1	9L,9H	49
8L 14530-B	Wiring assy (hydraulic seat regulator)-10 terminals-approximately 83" long	1	9L,9H,0L,1L	49-51
OH 14530	Wiring assy (hydraulic seat regulator)-10 terminals-approximately 88" long	1	OH	50
1H 14530-A	Wiring assy (hydraulic seat regulator)-12 terminals-approximately 88" long	1	1L,1H	51
8M 14531	Wiring assy (window switches)-8 terminals-approximately 132" long	1	9L74	49
OM 14531	Wiring assy (hydraulic window regulator)-8 terminals-approximately 131-1/2" long	1	0L74,1L74	50-51
OH 14531	Wiring assy (hydraulic window regulator)-front to rear-12 terminals-approximately 189" long	1	OH,1H, except 76	50-51
	356668-S32 Clip (rear window switch wiring to regulator panel-R.H.)	1	9H76,OH76	49-50
OM 14533	Wiring assy (radio pilot lamp jumper)-6" long	1	OL,OH	50
8M 14535	Wiring (hydraulic window switch jumper)-5" long	2	9L72,0L72,1L72	49-51

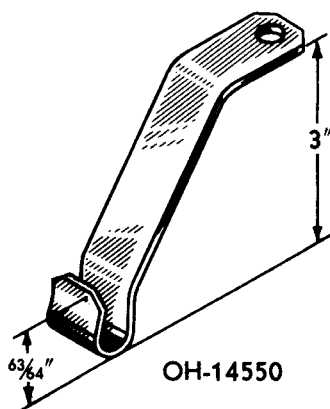

OH-14550

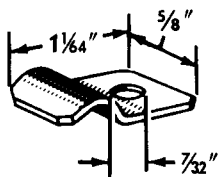

51A-14577-A

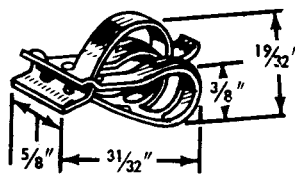

356668-S32

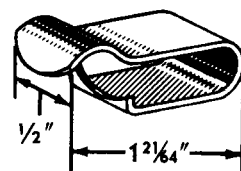

OIT-14585

PL-646

7RA 14550	NS	Clip (instrument wiring to instrument panel)-replaced by 8C-14197	as reqd	9L,9H	49
7RA 14550	NS	Clip (starter solenoid to hydraulic pump solenoid to front crossmember)-replaced by 8C-14197	2	OH,1H	50-51
7RA 14550	NS	Clip (battery to starter relay cable)-replaced by 8C-14197	1	OL,OH,1L,1H	50-51
		31527-S7 Screw (hex-hd self tapping)-No. 14-10 x 1/2"-clip to crossmember	3	OH,1H	50-51
OH 14550		Clip (hydraulic pump cable to front crossmember)	1	OL,OH,1L,1H	50-51
		31527-S7 Screw (hex washer hd self tapping)-No. 14-10 x 1/2"-clip to air duct	1	OL,OH,1L,1H	50-51
		41181-S8 Screw (hex-hd)-1/4"-20 x 1/2"-clip to front crossmember	3	OL,OH,1L,1H	50-51

# Lincoln and Lincoln Cosmopolitan

## CHASSIS PARTS CATALOGUE

PART NUMBER	PART NAME	NO. REQ'D	MODEL	YEAR
<b>Wiring-Continued</b>				
OH 14566-B	Support (fresh air control cable)	1	OH, 1H	50-51
8M 14567	Grommet (fuel gauge wire thru floor pan)	1	9L, 9H, OL, OH, 1L, 1H	49-51
51A 14577-A	Clip (cigar lighter wiring to garnish moulding and ash receptacle)	2	9L74, 9H73-74, OL74, OH74, 1L74	49-51
51A 14577-A	Clip (hydraulic tubing)	as reqd	9L, 9H, OL, OH, 1L, 1H	49-51
	32917-S7 Screw (pan head self tapping)- No. 10-12 x 3/8"	as reqd	9L, 9H, OL, OH, 1L, 1H	49-51
7EH 14577	Clip (headlamp and ignition wire harness)	1	9L, 9H, OL, OH	49-50
	32859-S7 Screw (rd-hd self tapping)- No. 10-12 x 1/2"-clip to fender apron	2	9L, 9H, OL, OH, 1L, 1H	49-51
	32924-S2 Screw (pan hd self tapping)- No. 10-12 x 1/2"-clip attaching	6	9L except 76	49
	42007-S7 Screw (hex-hd self tapping)- No. 10-12 x 1/2"-tubing to dash panel	2	9L76	49
7EH 14577	Clip (headlamp and ignition wire harness)	1	9L, 9H, OL, OH	49-50
B 14585	Clip (window solenoid switch wiring to cylinder bracket)	2	9H	49
OIT 14585	Clip (speedometer cable to frame)	2	9L, 9H, OL, OH, 1L, 1H	49-51
B 14586	Clip (foot switch wiring to rear LH fender apron)	1	9L, 9H, OL, OH	49-50
B 14586	Clip (back up lamp wiring)	2	OL, OH	50
B 14586	Clip (luggage compartment wiring)	2	OL	50
B 14586	Clip (package tray wiring)	2	OH	50
B 14586	Clip (rear lamp wiring)	2	OL	50
	351646-S32 Clip (body wiring to rear quarter deck flange)	3	9L, OL	49-50
OM 14587	NS Support (electrical wiring junction block assy)- secure locally	1	OL, OH, 1L, 1H	50-51
B 14592	Clip (hydraulic seat regulator wiring to floor pan)	3	9H, OH, 1H	49-51
11A 14598	Clip (hand brake cable to fender apron and frame)	1or2	9L, 9H	49
11A 14598	Clip (front seat back cigar lighter wiring)	2	1H74	51
8M 14599	Clip (attach fuel gauge wire to fuel tank)-spring type	3	9L, 9H, OL, OH, 1L, 1H	49-51
8M 14599	Clip (attach RH air control to glove compartment)- spring type	1	OL, 1L	50-51
91A 14602-A	Grommet (W/S wiper hose thru dash panel)-Rubber	1	9L, OL, 1L	49-51
91A 14602-A	Grommet (hand brake cable thru dash panel)-Rubber	1	9L, OL	49-50
91A 14602-A	Grommet (hydraulic window reg. insulator)-Rubber	2	9L, 9H, OL, OH, 1L, 1H	49-51
B 14603-B	Grommet (instrument panel wiring through air deflector)-Rubber	1or2	9L, 9H, OL, OH, 1L, 1H	49-51
1A 14603-B	Grommet (instrument panel wiring through dash)- Rubber	1	OL, OH, 1L, 1H	50-51
8L 14603	Grommet (instrument panel wiring through dash)- Rubber	1	9L, 9H	49
8M 14603-A	Grommet (rear lamp wiring through floor pan)-Rubber	2	9L76, 9H76, OH76, 1H76	49-51

# Lincoln and Lincoln Cosmopolitan

## CHASSIS PARTS CATALOGUE

PART NUMBER	PART NAME	NO. REQ'D	MODEL	YEAR 19__
-------------	-----------	-----------	-------	--------------

### Wiring-Continued

B 14605-A	Grommet (hood catch cable in dash)-Rubber	1	9L,9H,OL,OH	49-50
B 14605-A	Grommet (overdrive cable hole in dash)-Rubber	1	9L,9H	49
09A 14605	Grommet (for hood release cable control front air deflector)-Rubber	1	9L,9H,OL,OH,1L,1H	49-51
8A 14608	Retainer assy (instrument panel wiring through dash)	1	9L,9H,OL,OH,1L,1H	49-51
8A 14608	Retainer assy (antenna hose grommet)	1	9L,9H,OL,OH,1L,1H	49-51
8A 14608	Retainer assy (rear lamp wiring grommet at floor pan and dash)	2	1H76	51
	31498-S8 Screw (hex washer head)-No. 14-10 x 5/8"-retainer to splash apron	2	9L,9H,OL,OH,1L,1H	49-51
	31527-S7 Screw (hex-hd)-No. 14-10 x 1/2"-retainer to dash and floor pan	4	1H76	50
	31527-S7 Screw (hex-hd)-No. 14-10 x 1/2"-retainer to dash	2	9L,9H,OL,OH,1L,1H	49-51
59A 14615	Grommet (headlamp wiring through air defl.)-Rubber	2	9L,9H	49
0A 14615-A	Grommet (headlamp wire thru fender apron)	2	OL,OH,1L,1H	50-51
8M 14617	Grommet (license lamp wiring)-Rubber	1	9L,OL	49-50

### Clock

8L 15000	Clock assembly (electric)-Dull Black Face-with turn signal arrows	1	9L,9H	49
OL 15000	Clock assy (electric)-Dull Black Face-without turn signal arrows	1	OL,OH,1L,1H	50-51
	24366-S7 Bolt (hex-hd)-5/16"-18 x 7/8"	2	9L,9H	49
	34079-S7 Nut (hex)-No. 10-32	2	9L,9H	49
	37611-S7 Screw (fillister head pointed)-No. 8-32 x 1/4"	4	OL,OH,1L,1H	50-51
	78-13466 Bulb (clock)-2 C.P.-S.C.	1	9L,9H,OL,OH,1L,1H	49-51
8L 15010	Bezel (clock)	1	9L,9H	49
	42791-S8 Screw and washer assy (hex-hd)-No. 6-32 x 3/8	4	9L,9H	49
48 15021	Bulb (beam indicator)-1 C.P.-S.C.	1	9L,9H,OL,OH,1L,1H	49-51
48 15021	Bulb (turn indicator)-1 C.P.-S.C.	2	9L,9H,OL,OH,1L,1H	49-51
48 15021	Bulb (cigar lighter lamp)-1 C.P.-S.C.	1	OL,OH,1L,1H	50-51
8L 15026	Wire assy (electric clock)-6" long	1	9L,9H,OL,OH,1L,1H	49-51
NS	51A-14526-B Fuse (clock)-3 amp.-serviced in APA-14527-B Kit	1	9L,9H,OL,OH,1L,1H	49-51



# Lincoln and Lincoln Cosmopolitan

## CHASSIS PARTS CATALOGUE

PART NUMBER	PART NAME	NO. REQ'D	MODEL	YEAR
7EH 15200-A	Roadlamp assy-Amber lens	2	9L,9H	49
OL 15200	Roadlamp assy	2	OL,OH,1L,1H	50-51
21T 15207	Adapter (roadlamp locating ring)	2	9L,9H,OL,OH	49-50
OM 15207	Retainer (roadlamp ring)-used with serrated rim	4	OL,OH,1L,1H	50-51
1H 15209-A	Prop (roadlamp mounting)-1-1/2" diameter	2	1L,1H	51
1H 15211-A	Washer (roadlamp mounting)-1-9/16" diameter	2	1L,1H	51
7EH 15214	Ring (roadlamp retainer)	2	9L,9H	49
OM 15214	Rim (roadlamp)-serrated	2	OL,OH,1L,1H	50-51
11A 15220-B	Bulb (roadlamp)-Sealed Beam-Clear	2	9L,9H,OL,OH,1L,1H	49-51
11A 15220-C	Bulb (roadlamp)-Sealed Beam-Amber	2	9L,9H	49
8L 15224-B	Switch assy (roadlamp)-2-1/8" overall length	1	9L,9H	49
OL 15224	Switch assy (roadlamp)	1	OL,OH,1L,1H	50-51
1H 15226-A	Clamp (roadlamp wire)-strap-4" long	5	1L,1H	51
7EH 15227	Boot (roadlamp adjusting nut)	4	9L,9H	49
OM 15229	Ring (roadlamp unit retainer assy)	2	OL,OH,1L,1H	50-51
5EH 15231	Spring (roadlamp adapter retainer)	6	9L,9H	49
7EH 15233	Clip (roadlamp wiring loom)	3	9L,9H	49
5EH 15239	Wire (roadlamp ground)-5" long	2	9L,9H	49
7EH 15244	Wire assy (roadlamp lead)-30-1/2" long	2	9L,9H	49
OL 15246	Wire assy (roadlamp switch to left lamp)-118-1/2" long	1	OL,OH,1L,1H	50-51
OL 15248	Wire assy (roadlamp switch to headlamp switch)-18-1/2" long	1	OL,OH,1L,1H	50-51
5EH 15258	Yoke (roadlamp adjusting screw)	4	9L,9H	49
7EH 15262	Reinforcement and bracket assy (road and parking lamp)-RH	1	9L,9H	49
7EH 15263	Reinforcement and bracket assy (road and parking lamp)-LH	1	9L,9H	49
OL 15268	Bezel (roadlamp switch)	1	OL,OH	50
1H 15268-A	Bezel (roadlamp switch)	1	1L,1H	51
8C 15328	Rim assy (spotlight)	1	OL,OH	50
OL 15328	Door (spotlight lens)	1	OL,OH,1L,1H	50-51
6A 15330	Bulb assy (spotlight)-4-13/32" O.D.-Sealed Beam	1	9L,9H	49
8C 15330	Bulb assy (spotlight)-5-21/32" O.D.-Sealed Beam	1	9L,9H,OL,OH,1L,1H	49-51
51A 15332	Switch assy (spotlight)	1	9L,9H,OL,OH,1L,1H	49-51
OH 15500-B	Lamp assy (back up)	2	OL,OH,1L,1H	50-51
OH 15506	Wire assy (back up lamp switch to lamp)-170" long	1	OL,OH	50
1H 15506-A	Wire assy (back up lamp switch to lamp)-265" long	1	1L,1H	51
OH 15510	Gasket (back up lamp)-1-13/32" I.D. x 2-3/32" O.D.	2	OL,OH,1L,1H	50-51
8H 15513	Door (back up lamp)-3-1/2" dia.	2	9L,9H	49
OH 15513-A	Door (back up lamp)-2-13/32" dia.-10 serrations	2	OL,OH,1L,1H	50-51
OH 15513-B	Door (back up lamp)-3-1/2" dia.-24 serrations	2	OL,OH	50

# Lincoln and Lincoln Cosmopolitan

## CHASSIS PARTS CATALOGUE

PART NUMBER	CLASS	PART NAME	NO. REQ'D	MODEL	YEAR 19__
<b>Numerical List of 15,000 Miscellaneous Accessories—Continued</b>					
8H 15514		Lens (back up lamp)-3-3/16" dia.	2	9L,9H	49
OH 15514		Lens (back up lamp)-1-57/64" dia.	2	OL,OH,1L,1H	50-51
8L 15517		Bracket (back up lamp switch mounting)	1	9L,9H,OL,OH,1L,1H	49-51
51A 15520-A		Switch assy (back up lamp)	1	9L,9H,OL,OH	49-50
1H 15520-A		Switch assy (back up lamp)	1	1L,1H	51
OH 15522		Retainer (back up lamp lens)	6	OL,OH	50
8L 15523		Washer (back up lamp mounting)	1	9L,9H,OL,OH	49-50
8L 15525		Wire assy (back up lamp)-30" long	1	9L,9H,OL,OH	49-50
1H 15525-A		Wire assy (back up lamp switch to rear lamp feed)- 35" long	1	1L,1H	51
OH 15527-B		Wire (back up lamp)-LH to RH-53" long	1	OL,OH,1L,1H	50-51
8H 15529-B		Spacer (back up lamp inner mounting)	1	9L,9H,OL,OH	49-50
8M 15532	NS	Spacer (back up lamp)-outer-extended type lamp- serviced in 8H-18275-B and ED-OH-18275 Kits	1	OL,OH	50
OH 15533		Pad (back up lamp)-1-1/2" I.D. x 2-1/2" O.D.	2	OL,OH,1L,1H	50-51
8H 15550		Lamp assy (utility)-one bulb type	1	9L,9H,OL,OH,1L,1H	49-51
1H 15550-A		Lamp assy (utility)-two bulb type	1	9L,9H,OL,OH,1L,1H	49-51
HAK 15550-A		Kit (emergency utility lamp and case)-includes 1H-15550-A lamp	1	9L,9H,OL,OH,1L,1H	49-51
8L 15650		Map light assy (instrument control panel)	1	9L,9H	49
OL 15650		Map light assy (instrument control panel)	1	OL,OH,1L,1H	50-51
*8H 15800-AP		Housing assy (transmission gear shift indicator lamp)-in Prime	1	9L,9H,OL,OH,1L,1H	49-51
*8L 15805		Dial (transmission gear shift indicator)	1	9L,9H	49
*OL 15805		Dial (transmission gear shift indicator)	1	OL,OH,1L,1H	50-51
		41800-88 Screw (flat head self tapping)- No. 6-32 x 1/4"	2	OL,OH,1L,1H	50-51
*8L 15812		Switch and bracket assy (trans. gear shift neutral)	1	9L,9H,OL,OH	49-50
*1L 15812-A		Switch assy (transmission gear shift neutral)	1	1L,1H	51
		42360-87 Screw (hex washer head)-No. 10- 16 x 3/8"-switch to steering column	2	9L,9H,OL,OH,1L,1H	49-51
8M 15852		Switch assy (hand brake signal lamp)	1	9L,9H	49
8M 15853		Bracket assy (hand brake signal lamp)	1	9L,9H	49
OH 15853		Bracket assy (hand brake signal lamp)	1	OL,OH,1L,1H	50-51
OH 15855		Flasher and sleeve assy (hand brake signal lamp)	1	9L,9H,OL,OH,1L,1H	49-51
8M 15856		Lens assy (hand brake signal lamp)	1	9L,9H,OL,OH,1L,1H	49-51

\* Used with HYDRA-MATIC transmission

# Lincoln and Lincoln Cosmopolitan

## CHASSIS PARTS CATALOGUE

PART NUMBER	SUBFC	PART NAME	NO. REQ'D	MODEL	YEAR 19__
<b>Front Fender</b>					
1H 16003		Moulding (front fender)-RH	1	1H	51
1L 16003		Moulding (front fender)-RH	1	1L	51
1H 16004		Moulding (front fender)-LH	1	1H	51
1L 16004		Moulding (front fender)-LH	1	1L	51
		1L-7220995-B Retainer (front fender moulding)	8	1L,1H	51
		1L-16214 Retainer (front fender moulding)	2	1L,1H	51
		34823-S2 Lockwasher-No. 10-retainer to front fender	2	1L,1H	51
		34823-S2 Lockwasher-No. 10-moulding to front fender	12	1H	51
		34079-S7 Nut (hex)-No. 10-32-retainer to front fender	2	1L,1H	51
		34079-S7 Nut (hex)-No. 10-32-moulding to front fender	12	1H	51
		27113-S8 Screw (round head)-No. 10-32 x 3/4"-retainer to front fender	2	1L,1H	51
		44713-S8 Washer (flat)-No. 10-retainer to front fender	2	1L,1H	51
		44713-S8 Washer (flat)-No. 10-moulding to front fender	12	1H	51
8H 16005		Fender assy (front)-RH	1	9H	49
OH 16005-A		Fender assy (front)-RH	1	OH	50
8L 16005-A		Fender assy (front)-RH	1	9L	49
OL 16005		Fender assy (front)-RH	1	OL	50
8H 16006		Fender assy (front)-LH	1	9H	49
8L 16006-A		Fender assy (front)-LH	1	9L	49
OH 16006-A		Fender assy (front)-LH	1	OH	50
OL 16006		Fender assy (front)-LH	1	OL	50
1H 16008-J		Fender assy (front)-RH	1	1H	51
1L 16008-G		Fender assy (front)-RH	1	1L	51
1H 16009-J		Fender assy (front)-LH	1	1H	51
1L 16009-G		Fender assy (front)-LH	1	1L	51
		8L-16724 Medallion (front fender)-side-"Lincoln"	2	9L	49
		8H-16724-B Medallion (front fender)-side-"Lincoln"	2	9H	49
		8H-16724-C Medallion (front fender)-side-"Cosmopolitan"	2	9H	49
		OL-16724 Medallion (front fender)-side-"Lincoln"	2	OL,1L	50-51
		OH-16724 Medallion (front fender)-side lower-"Cosmopolitan"	2	OH,1H	50-51
		78-706865 Washer (cup)-fender to stone deflector	4	1L,1H	51
		24366-S8 Bolt (hex-hd)-5/16"-18 x 7/8"	2	9L,OL,1L	49-51
		24367-S7 Bolt (hex-hd)-5/16"-24 x 7/8"-fender to apron	12	OL,OH,1L,1H	50-51
		24367-S7 Bolt (hex-hd)-5/16"-24 x 7/8"-fender to grille catwalk	8	OL,OH,1L,1H	50-51
		43261-S7 Bolt and lockwasher (hex head)-1/4"-20 x 7/8"	4	9H,OH	49-50
		34392-S7 Locknut-5/16"-18	2	9L,OL	49-50
		34940-S2 Lockwasher (external tooth)-1/4"	4	9H,OH	49-50
		34393-S7 Nut (hex lock)-5/16"-24-fender to fender apron	2	1L	51

# Lincoln and Lincoln Cosmopolitan

## CHASSIS PARTS CATALOGUE

PART NUMBER	PART NAME	NO. REQ'D	MODEL	YEAR 19__
<b>Front Fender—Continued</b>				
34806-S7	Lockwasher-5/16"-fender to rocker panel	2	1L	51
34941-S7	Lockwasher (external tooth)-5/16"-fender to apron	12	0L,0H,1L,1H	50-51
34941-S7	Lockwasher (external tooth)-5/16"-fender to grille catwalk	8	0L,0H,1L,1H	50-51
350786-A-S7	Nut (speed)-No. 12	8or 14	9L,9H,0L,0H	49-50
350949-S32	Nut (speed)-5/16"	14	9L,9H,0L,0H	49-50
355880-S32	Nut (speed)-No. 14-front fender to cowl	12	9H,0H	49-50
357227-S	Nut (retainer)-1/4"-20-fender to cowl panel	2	0L,1L	50-51
357256-S2	Nut (retainer)-5/16"-24-fender to fender apron	10or 12	9L,9H,0L,0H,1L,1H	49-51
357246-S2	Nut (retainer)-5/16"-24-fender to grille air deflector	8	0L,0H,1L,1H	50-51
357257-S2	Nut (retainer)-5/16"-24-fender to stone deflector	6	9L,9H,0L,0H,1L,1H	49-51
357257-S2	Nut (retainer)-5/16"-24-fender to radiator grille air deflector	6	9L,9H,0L,0H,1L,1H	49-51
42719-S	Screw and washer assy (hex-hd)-5/16"-18 x 5/8"-fender to cowl panel	8	9H,0H	49-50
42789-S8	Screw and lockwasher assy (hex head)-5/16"-18 x 3/4"	4	9L,9H	49
43263-S8	Screw and lockwasher (hex-hd)-1/4"-20 x 5/8"-fender to cowl panel	2	0L,1L	50-51
43264-S8	Screw and washer (hex head)-5/16"-24 x 7/8"-fender to stone deflector	6	0L,0H,1L,1H	50-51
43264-S8	Screw and washer (hex head)-5/16"-24 x 7/8"-fender to radiator grille air deflector	8	0L,0H,1L,1H	50-51
43264-S8	Screw and washer (hex head)-5/16"-24 x 7/8"-fender to grille opening	4	0L,0H,1L,1H	50-51
357798-S8	Screw and lockwasher assy (hex head)-5/16"-12 x 7/8"	2	9H,0H	49-50
44722-S8	Washer (flat)-5/16"-fender to front fender apron	12	9L,9H,0L,0H,1L,1H	49-51
44722-S8	Washer (flat)-5/16"-fender to stone deflector	6	0L,0H,1L,1H	50-51
44722-S8	Washer (flat)-5/16"-fender to grille air upper deflector	8	0L,0H,1L,1H	50-51
44722-S8	Washer (flat)-5/16"-fender to radiator grille deflector	6	0L,0H,1L,1H	50-51
44724-S8	Washer (flat)-5/16"-fender to cowl side panel	2or4	0L,0H	50
44724-S8	Washer (flat)-5/16"-fender bracket to splash shield apron	2	1L	51
44724-S8	Washer (flat)-5/16"-fender to rocker panel	2	1L	51

# Lincoln and Lincoln Cosmopolitan

## CHASSIS PARTS CATALOGUE

PART NUMBER	PART NAME	NO. REQD	MODEL	YEAR
<b>Front Fender—Continued</b>				
8L 16024	Moulding and stud assy (fender side)-RH	1	9L,OL,1L	49-51
8L 16025	Moulding and stud assy (fender side)-LH	1	9L,OL,1L	49-51
	34803-S7 Lockwasher-No. 10	16	9L,OL,1L	49-51
	34053-S8 Nut (hex)-No. 10-24	16	9L,OL,1L	49-51
	352775-S34 Stud (screw)-No. 10-24 x 1"- part of 8L-16024 & 5	16	9L,OL,1L	49-51
	44713-S8 Washer (flat)-No. 10-(1/2" x 3/64")-moulding to fender	10	9L,OL,1L	49-51
	44730-S8 Washer (flat)-7/16"	2	9L,OL,1L	49-51
	351600-S8 Washer (cup)-3/16"-moulding to fender	2	9L,OL,1L	49-51
	357776-S8 Washer (cup)-7/32" I.D. x 13/16" O.D. x 5/16"	16	9L,OL,1L	49-51
8H 16054-A	Apron assy (front fender)-RH	1	9H	49
OH 16054	Apron assy (front fender)-RH	1	OH,1H	50-51
8L 16054-B	Apron assy (front fender)-RH	1	9L	49
OL 16054	Apron assy (front fender)-RH	1	OL,1L	50-51
8H 16055-A	Apron assy (front fender)-LH	1	9H	49
OH 16055	Apron assy (front fender)-LH	1	OH,1H	50-51
8L 16055-B	Apron assy (front fender)-LH	1	9L	49
OL 16055	Apron assy (front fender)-LH	1	OL,1L	50-51
	24308-S8 Bolt (hex head)-1/4"-20 x 1/2"	2	9L,OL	49-50
	24324-S2 Bolt (hex head)-1/4"-20 x 5/8"	4	9L,9H,OL,OH	49-50
	24367-S2 Bolt (hex head)-5/16"-24 x 7/8"	2	9L,OL,1L	49-51
	24389-S8 Bolt (hex head)-3/8"-24 x 1"	2	9L,9H,OL,OH,1L,1H	49-51
	351724-S2 Bolt (hex head)-5/16"-10 x 3/4"	6	9L,9H,OL,OH	49-50
	355428-S Grommet (fresh air control wire thru fender apron)-Rubber	1	OH	50
	34393-S7 Locknut-5/16"-24	2	9L,OL,1L,1H	49-51
	34805-S8 Lockwasher-1/4"	4	9L,OL,1L	49-51
	34807-S2 Lockwasher-3/8"	2	9L,9H,OL,OH,1L,1H	49-51
	33795-S7 Nut (hex)-1/4"-20-apron to splash panel	12	OL,1L	50-51
	33800-S8 Nut (hex)-3/8"-24-apron to frame side member	2	9L,9H,OL,OH,1L,1H	49-51
	34390-S7 Nut (hex)-1/4"-20	2	9L72-74,OL	49-50
	356115-S32 Nut (speed)-No. 14	11	9L,OL	49-50
	357252-S2 Nut (cage)-5/16"-24-apron to radiator support	8	9L,9H,OL,OH	49-50
	357257-S2 Nut (retainer)-5/16"-24-apron to side air deflector	6	9L,9H,OL,OH,1L,1H	49-51
	31527-S8 Screw (hex washer head self tap.)-No. 14-14 x 1/2"-apron to frame & radiator support	2	9L,9H,OL,OH	49-50
	42143-S8 Screw (hex washer head self tap.)-No. 14-10 x 3/4"	11	9H,OH	49-50
	43263-S8 Screw & washer (hex-hd)-1/4"- 20 x 5/8"-apron to splash panel	12	OL,1L	50-51
	43264-S8 Screw & washer (hex-hd)-5/16"- 24 x 7/8"-apron to side air deflector	6	OL,OH,1L,1H	50-51
	355192-S7 Screw & lockwasher assy (hex head)-1/4"-20 x 5/8"	4	9H,OH	49-50

# Lincoln and Lincoln Cosmopolitan

## CHASSIS PARTS CATALOGUE

PART NUMBER	PART NAME	NO. REQ'D	MODEL	YEAR
<b>Front Fender—Continued</b>				
	44720-S8 Washer (flat)-1/4"	2	9L,9H,OL,OH,1L,1H	49-51
	44722-S8 Washer (flat)-5/16"	8	9L,9H,OL,OH,1L,1H	49-51
	44728-S8 Washer (flat)-3/8"	6	9L,9H,OL,OH,1L,1H	49-51
	356381-S7 Washer (flat)-3/8"	4	9L,OL,1L	49-51
8L 16068	Anti squeak (front fender to front fender apron)- 48-5/64" long	2	9L,OL,1L	49-51
8H 16068	Anti squeak (front fender to front fender apron)- 59-3/16" long	2	9H,OH,1H	49-51
8H 16070-A	Anti squeak (front fender apron to frame)-1-7/64" long	1	9H,OH,1H	49-51
8L 16070-A	Anti squeak (front fender apron to frame)-13-1/4" long	2	9L,OL,1L	49-51
8H 16071	Anti squeak (front fender to cowl side)-11-41/64" long	2	9H,OH,1H	49-51
1H 16079	Plate (front fender)-name-"Capri"	2	1H72C	51
1L 16079	Plate (front fender)-name-"Lido"	2	1L72C	51
	350786-AS7-8 Nut (speed)-No. 12-plate to fender	10	1L72C,1H72C	51
7EH 16094	Brace and bracket assy (front fender)-RH	1	9H,OH	49-50
7EH 16095	Brace and bracket assy (front fender)-LH	1	9H,OH	49-50
7EH 16096	Brace assy (front fender)-RH	1	9H,OH	49-50
1H 16096	Brace assy (front fender)-RH	1	1H	51
OH 16096	Brace assy (front fender)-RH	1	OH	50
7EH 16097	Brace assy (front fender)-LH	1	9H,OH	49-50
OH 16097	Brace assy (front fender)-LH	1	OH	50
1H 16097	Brace assy (front fender)-LH	1	1H	51
	24324-S7-8 Bolt (hex-hd)-1/4"-20 x 5/8"	2	9H,OH,1H	49-51
	24347-S8 Bolt (hex head)-5/16"-24 x 3/4" -fender bracket to cowl strainer	4	9L,OL,1L	49-51
	43260-S8 Bolt & lockwasher (hex-hd)-1/4" -20 x 1/2"-brace to splash	2	OH,1H	50-51
	43260-S8 Bolt and lockwasher (hex-hd)- 1/4"-20 x 1/2"-brace to brkt.	4	OH,1H	50-51
	43260-S8 Bolt and lockwasher (hex-hd)- 1/4"-20 x 1/2"-brace to fender	4	OH,1H	50-51
	34905-S7 Lockwasher (internal tooth)-1/4"	2	9H,OH,1H	49-51
	33795-S7 Nut (hex)-1/4"-20-brace to fender	2	9H,OH,1H	49-51
	33795-S7 Nut (hex)-1/4"-20-brace to dash and frame	2	9H,OH,1H	49-51
	357227-S Nut (retainer)-1/4"-20-brace to fender bracket	2	1H	51
	42143-S8 Screw (hex washer head self tapping)-No. 14-10 x 3/4"	2	9H,OH	49-50
	43264-S8 Screw & washer (hex-hd)-5/16"- -24 x 7/8"-brace to cowl panel	4	1L	51
	357225-S8 Screw & washer (hex-hd)-1/4"- 20 x 1/2"-brace to fender panel	2	1H	51
	34940-S2 Washer (lock)-1/4"-brace to dash panel	2	1H	51
	44720-S8 Washer (flat)-1/4"-brace to dash panel	2	1H	51

# Lincoln and Lincoln Cosmopolitan

## CHASSIS PARTS CATALOGUE

PART NUMBER	PART NAME	NO. REQ'D	MODEL	YEAR
1L 16116	Extension (front fender name plate)	4	1L72C, 1H72C	51
7EH 16132	Weatherstrip (front fender brace)-19" long	2	9H, OH	49-50
OL 16138	Support assy (front fender apron and radiator)	1	9L, 9H, OL, OH, 1L, 1H	49-51
	23441-S7 Bolt (carriage)-3/8"-24 x 1-1/4"-support to frame	2	9L, 9H, OL, OH, 1L, 1H	49-51
	350479-S2 Bolt (hex-hd)-5/16"-10 x 5/8"	4	9L, 9H, OL, OH	49-50
	351724-S2 Bolt (hex head)-5/16"-20 x 3/4"-support to fender apron	6	OL, OH, 1L, 1H	50-51
	33800-S8 Nut (hex)-3/8"-24-support to frame	2	9L, 9H, OL, OH, 1L, 1H	49-51
	357252-S2 Nut (cage)-5/16"-24-support to fender apron and bracket	8	9L, 9H, OL, OH, 1L, 1H	49-51
	356060-S32 Nut (speed)-5/16"-10	14	9L, 9H, OL, OH, 1L, 1H	49-51
	356595-S Plate (radiator support locking)	1	9L, 9H, OL, OH, 1L, 1H	49-51
	44724-S8 Washer (flat)-5/16"-support to radiator support bracket	4	OL, OH	50
OL 16152	Bar (front fender apron and radiator)	1	9L, 9H, OL, OH, 1L, 1H	49-51
	24347-S8 Bolt (hex-hd)-5/16"-24 x 3/4"-bar to radiator support	4	OL, OH, 1L, 1H	50-51
	34806-S7 Lockwasher-5/16"-bar to radiator support	4	OL, OH, 1L, 1H	50-51
	350846-S32 Nut (speed)-No. 14	3	9L, 9H, OL, OH	49-50
	357252-S2 Nut (cage)-5/16"-24-bar to radiator support	4	9L, 9H, OL, OH, 1L, 1H	49-51
	357253-S2 Nut (cage)-1/4"-28-bar to radiator support	3	OL, OH, 1L, 1H	50-51
	42143-S7 Screw (hex washer head self tapping)-No. 14-10 x 3/4"	3	9L, 9H, OL, OH, 1L, 1H	49-51
8M 16186	Pad (front fender apron and radiator support)-Rubber Composition	as reqd	9L, 9H, OL, OH, 1L, 1H	49-51
	8L-16554 Shield (radiator support to front cross member splash)-RH	1	9L, 9H, OL, OH, 1L, 1H	49-51
	8L-16555 Shield (radiator support to front cross member splash)-LH	1	9L, 9H, OL, OH, 1L, 1H	49-51
OL 16188	Ornament assy (front fender side)	2	OL72C	50
1H 16188	Ornament assy (front fender side)-RH	1	1H	51
1L 16188	Ornament assy (front fender side)-RH	1	1L	51
1H 16189	Ornament assy (front fender side)-LH	1	1H	51
1L 16189	Ornament assy (front fender side)-LH	1	1L	51
	34053-S8 Nut (hex head)-No. 10-24-ornament to fender	6	1L, 1H	51
	352419-S8 Stud (screw)-No. 10-24 x 13/16"-ornament to fender	6	1L, 1H	51
	34803-S7 Lockwasher-No. 10-ornament to fender	6	OL, 1L	50-51
	34805-S8 Lockwasher-1/4"	4	9H, OH	49-50
	33795-S7 Nut (hex)-1/4"-20	4	9H, OH	49-50
	350900-S32 Nut (speed)-No. 10	20	9H, OH	49-50
	355321-S7 Retainer assy (moulding)	2	9H, OH	49-50
	42134-S8 Screw (hex washer head self tapping)-No. 10-12 x 5/8"	18	9H, OH	49-50
	351600-S8 Washer (cup)-moulding retainer-ornament to fender	6	1L, 1H	51

# Lincoln and Lincoln Cosmopolitan

## CHASSIS PARTS CATALOGUE

PART NUMBER	PART NAME	NO. REQ'D	MODEL	YEAR 19__
<b>Front Fender—Continued</b>				
8H 16196	Moulding assy (front fender)-center-RH	1	9H,OH	49-50
8H 16197	Moulding assy (front fender)-center-LH	1	9H,OH	49-50
8H 16209-A	Clip (front fender moulding)-inner-upper	6	9L,9H,OL,OH	49-50
8H 16210	Moulding (front fender)-inner-RH	1	9L,9H	49
OL 16210	Moulding (front fender lower edge curb buffer)-RH	1	OL,LL	50-51
8H 16211	Moulding (front fender)-inner-LH	1	9L,9H	49
OL 16211	Moulding (front fender lower edge curb buffer)-LH	1	OL,LL	50-51
	350190-S8 Bolt (special carriage pointed) -No. 10-24 x 1/2"	10	OL,LL	50-51
	350057-S7 Screw and lockwasher assy (slotted hex head)-No. 10-24 x 7/16"-moulding to fender	6	9L,9H	49
	34053-S8 Nut (hex)-No. 10-24- moulding to fender	6	OL,LL	50-51
	44713-S8 Washer (flat)-No. 10-moulding to fender	6	OL,LL	50-51
1L 16214	Retainer assy (front fender moulding)	2	1L,1H	51
1L 16214	Retainer assy (front door and rear fender moulding)	6	1L	51
	34053-S8 Nut (hex)-No. 10-24-retainer to fender	2	1L,1H	51
OH 16222	Bracket (front body hinge pillar to fender)-lower	2	OH,1H	50-51
	42783-S8 Bolt and lockwasher (hex-hd)- 3/8"-24 x 7/8"-bracket to front fender filler bracket	4	OH,1H	50-51
	42783-S8 Bolt and lockwasher (hex-hd)- 3/8"-24 x 7/8"-bracket to hinge pillar	4	OH,1H	50-51
	44726-S8 Washer (flat)-3/8"-bracket to front fender filler bracket	4	OH,1H	50-51
8L 16234	Anti squeak (front fender apron to brace assy dash to frame)-5-5/8" long	4	9L,OL,1L	49-51
8H 16234	Anti squeak (front fender apron to brace assy dash to frame)-7-1/4" long	4	9H,OH,1H	49-51
8H 16238	Clip (front fender side moulding)	10	9H,OH	49-50
OH 16238	Clip (front fender side moulding)	10	OL,LL	50-51
	42134-S8 Screw (hex washer hd self tap.) -No. 10-10 x 5/8"	10	9H,OH	49-50
	42360-S8 Screw (hex washer hd self tap.) -No. 10-16 x 3/8"	8	9H,OH	49-50
OL 16247	Seal (front fender to grille extension)	2	OL,OH	50
7EH 16262-A	Weatherstrip (front fender apron to dash panel)- 15-27/32" long-RH	1	9H,OH,1H	49-51
7EH 16263-A	Weatherstrip (front fender apron to dash panel)- 15-27/32" long-LH	1	9H,OH,1H	49-51
7EH 16263-B	Weatherstrip (front fender apron to dash panel)- 15-27/32" long-less notches	2	9H,OH	49-50
OH 16298	Bracket (cowl side panel to fender support)-RH	1	OH,1H	50-51
OH 16299	Bracket (cowl side panel to fender support)-LH	1	OH,1H	50-51
	20326-S7 Bolt (hex-hd)-5/16"-18 x 5/8"- bracket to fender body	2	OH,1H	50-51
	34941-S7 Lockwasher-5/16"-bracket to fender body	2	OH,1H	50-51
	44724-S8 Washer (flat)-5/16"-bracket to fender body	4	OH,1H	50-51



# Lincoln and Lincoln Cosmopolitan

## CHASSIS PARTS CATALOGUE

PART NUMBER	PART NAME	NO. REQ'D	MODEL	YEAR 19
<b>Rear Fender</b>				
8L 16312-A	Fender assy (rear)-RH	1	9L72-76,OL72	49-50
8L 16312-C	Fender assy (rear)-RH	1	9L74,OL74	49-50
1L 16312-H	Fender assy (rear)-RH	1	1L74	51
1L 16312-J	Fender assy (rear)-RH	1	1L72	51
8L 16313-A	Fender assy (rear)-LH	1	9L72-76,OL72	49-50
8L 16313-C	Fender assy (rear)-LH	1	9L74,OL74	49-50
1L 16313-H	Fender assy (rear)-LH	1	1L74	51
1L 16313-J	Fender assy (rear)-LH	1	1L72	51
	24327-S7-8 Bolt (hex head)-5/16"-24 x 5/8" -fender to quarter panel	8	9L,OL,1L	49-51
	24327-S7-8 Bolt (hex head)-5/16"-24 x 5/8"-fender to quarter hinge pillar	6	9L,OL,1L	49-51
	39075-S7 Bolt (binding head)-5/16"-24 x 5/8"	6	9L72,OL72,1L72	49-51
	34081-S7 Nut (hex)-1/4"-28-fender to floor pan filler	2	1L	51
	34393-S7 Nut (lock)-5/16"-24-fender to quarter panel	10	9L,OL,1L	49-51
	34393-S7 Nut (lock hex)-5/16"-24-fender to quarter hinge pillar	8	OL,1L	50-51
	39909-S7 Screw (hex washer head self tapping)-5/16"-18 x 3/4"	6	9L72,OL72,1L72	49-51
	42904-S8 Screw and lockwasher (hex-hd)- 1/4"-28 x 5/8"-fender to to floor pan filler	2	1L	51
	42905-S8 Screw & washer assy (hex head)- 5/16"-24 x 3/4"-fender to quarter panel	16	9L,OL,1L	49-51
	43264-S8 Screw and washer (hex head)- 5/16"-24 x 7/8"-fender to quarter panel	16	OL,1L	50-51
	44720-S8 Washer (flat)-1/4"-fender to floor pan filler	2	1L	51
	44722-S8 Washer (flat)-5/16"-fender to quarter hinge pillar	2	9L74,OL74,1L74	49-51
	44728-S8 Washer (flat)-3/8"-fender to quarter panel	8or 10	OL,1L	50-51
	356326-S7 Washer (flat)-25/64" I.D. x 1-1/8" O.D.-fender to quarter panel	8or 10	OL,1L	50-51
8M 16318-A	Reinforcement (rear fender to body)-front-RH	1	9L72-76,OL72,1L72	49-51
8M 16318-B	Reinforcement (rear fender to body)-front-RH	1	9L74,OL74,1L74	49-51
1M 16318	Reinforcement (rear fender to body)-front-RH	1	1L74	51
8M 16319-A	Reinforcement (rear fender to body)-front-LH	1	9L72-76,OL72,1L72	49-51
8M 16319-B	Reinforcement (rear fender to body)-front-LH	1	9L74,OL74,1L74	49-51
1M 16319	Reinforcement (rear fender to body)-front-LH	1	1L74	51
8M 16320-B	Anti squeak (rear fender to body)-20-1/4" long	2	9L,OL, except 74	49-50
8M 16320-C	Anti squeak (rear fender to body)-20-1/2" long	2	9L74,OL74,1L74	49-51
8M 16320-E	Anti squeak (rear fender to pillar)-16-7/8" long	2	9L72,OL72	49-50
1M 16320	Anti squeak (rear fender to pillar)-17-55/64" long	2	1L72	51
8M 16340	Brace (rear fender)-RH	1	9L,OL,1L	49-51
8M 16341	Brace (rear fender)-LH	1	9L,OL,1L	49-51
	24324-S8 Bolt (hex-hd)-1/4"-20 x 5/8"- rear fender brace to rear floor pan	4	9L,OL,1L	49-51

# Lincoln and Lincoln Cosmopolitan

## CHASSIS PARTS CATALOGUE

PART NUMBER	PART NAME	NO. REQ'D	MODEL	YEAR 19
<b>Rear Fender—Continued</b>				
	24344-S7 Bolt (hex-hd)-1/4"-20 x 3/4"-rear fender brace to rear fender	4	9L,OL,1L	49-51
	34390-S7 Nut (lock hex)-1/4"-20-brace to rear floor pan	4	9L,OL,1L	49-51
	34390-S7 Nut (lock hex)-1/4"-20-brace to rear fender	4	9L,OL,1L	49-51
	44719-S8 Washer (flat)-1/4"-brace to rear floor pan	4	9L,OL,1L	49-51
	44719-S8 Washer (flat)-1/4"-brace to rear fender	4	9L,OL,1L	49-51
8M 16346-A	Anti squeak (rear fender to body)-80-37/64" long	2	9L72-76,OL72	49-50
8M 16346-B NS	Anti squeak (rear fender to body)-60-3/8" long-make from 8M-16346-A	2	9L74,OL74	49-50
1M 16346-A NS	Anti squeak (rear fender to body)-73-21/32" long-make from 8M-16346-A	2	1L72	51
1M 16346-B NS	Anti squeak (rear fender to body)-53-7/16" long-make from 8M-16346-A	2	1L74	51
06H 16377	Spring (battery drain hose to frame)	1	9L,9H,OL,OH,1L,1H	49-51
0A 16377	Spring (gas tank filler neck lid hinge)-1-9/32" wide	2	OL,1L	50-51
8H 16377	Spring (gas tank filler neck lid hinge)-7/16" wide	2	9H,OH,1H	50-51
8M 16377	Spring (gas tank filler neck lid hinge)-1-1/4" wide	1	9L,OL	49-50
06H 16378-A	Bumper (rear fender filler neck lid)-Rubber	2	9H,OH	49-50
8M 16381	Sealer (rear fender reinforcement to body front)-Rubber	2	9L72-76,OL-72,1L72	49-51
1L 16446	Brace (rear fender)-with slotted holes	2	1L	51
1M 16446-B	Brace (rear fender)-with 2 round holes	2	1L	51
	357254-S2 Nut (retainer)-1/4"-28-brace to floor pan filler	4	1L	51
	357254-S2 Nut (retainer)-1/4"-28-brace to fender	2	1L	51
	42904-S8 Screw and lockwasher (hex-hd)-1/4"-28 x 5/8"-brace to fender	2	1L	51
	42904-S8 Screw and lockwasher (hex-hd)-1/4"-28 x 5/8"-brace to floor pan filler	4	1L	51
	43264-S8 Screw and washer (hex head)-5/16"-24 x 7/8"-brace to floor pan filler	4	1L	51
	44722-S8 Washer (flat)-5/16"-brace to floor pan filler	4	1L	51
8L 16554	Shield (radiator support to front cross member splash)-RH	1	9L,9H,OL,OH,1L,1H	49-51
8L 16555	Shield (radiator support to front cross member splash)-LH	1	9L,9H,OL,OH,1L,1H	49-51
	355880-S32 Nut (speed)-No. 14-splash shield to stone deflector	17	9L,9H,OL,OH,1L,1H	49-51
	31527-S7 Screw (hex washer head)-No. 14-14 x 1/2"-shield to cross member and radiator support	4	9L,9H,OL,OH,1L,1H	49-51
8H 16564	Anti squeak (radiator splash shield to stone deflector)-63-3/16" long	1	9L,9H,OL,OH,1L,1H	49-51

# Lincoln and Lincoln Cosmopolitan

## CHASSIS PARTS CATALOGUE

PART NUMBER	PART NAME	NO. REQ'D	MODEL	YEAR
<b>Rear Wheel Cover</b>				
NS 1L-13973	Kit (rear fender shield installation)-consists of the following-service details (1) 1L-7227968 Cover (1) 1L-7227969 Cover (1) 1L-7227986 Seal (1) 1L-7227987 Seal (1) 1L-7227996-B Retainer (1) 1L-7227997-B Retainer (1) 1L-7228000 Bracket (1) 1L-7228001 Bracket (1) 1L-7228002 Bracket (1) 1L-7228003 Bracket (2) 8L-7328006 Clip	1	1L	51
1L-7227968	Cover assy (quarter panel wheel opening)-RH	1	1L	51
1L-7227969	Cover assy (quarter panel wheel opening)-LH	1	1L	51
1L-7227986	Seal (quarter panel wheel opening cover)-RH-58-3/4" long	1	1L	51
1L-7227987	Seal (quarter panel wheel opening cover)-LH-58-3/4" long	1	1L	51
1L-7227996-B	Retainer (quarter panel wheel cover seal)-RH	1	1L	51
1L-7227997-B	Retainer (quarter panel wheel cover seal)-LH	1	1L	51
8H-7327968	Cover assy (quarter panel wheel opening)-RH	1	9H	49
OH-7327968	Cover assy (quarter panel wheel opening)-RH	1	OH,1H	50-51
8L-7327968	Cover assy (quarter panel wheel opening)-RH	1	9L,OL	49-50
8H-7327969	Cover assy (quarter panel wheel opening)-LH	1	9H	49
OH-7327969	Cover assy (quarter panel wheel opening)-LH	1	OH,1H	50-51
8L-7327969	Cover assy (quarter panel wheel opening)-LH	1	9L,OL	49-50
8H-7327986	Seal (quarter panel wheel opening cover)-Rubber-55-9/64"	2	9L,9H,OL,OH	49-50
OH-7227986	Seal (quarter panel wheel opening cover)-RH-55-9/64" long	1	OH,1H	50-51
OH-7227987	Seal (quarter panel wheel opening cover)-LH-55-9/64" long	1	OH,1H	50-51
8H-7327996	Retainer (quarter panel wheel cover seal)-RH	1	9H,OH,1H	49-51
8L-7327996	Retainer (quarter panel wheel cover seal)-RH	1	9L,OL	49-50
8H-7327997	Retainer (quarter panel wheel cover seal)-LH	1	9H,OH,1H	49-51
8L-7327997	Retainer (quarter panel wheel cover seal)-LH	1	9L,OL	49-50

# Lincoln and Lincoln Cosmopolitan

## CHASSIS PARTS CATALOGUE

PART NUMBER	QTY	PART NAME	NO. REQ'D	MODEL	YEAR 19__
-------------	-----	-----------	-----------	-------	--------------

### Rear Wheel Cover—Continued

	8H-7328000	Bracket (quarter panel wheel cover guide)-front-RH	1	9H,0H,1H	49-51
	8L-7328000	Bracket (quarter panel wheel cover guide)-front-RH	1	9L,0L	49-50
	1L-7228000	Bracket (quarter panel wheel opening cover)-front-RH	1	1L	51
	8H-7328001	Bracket (quarter panel wheel cover guide)-front-LH	1	9H,0H,1H	49-51
	8L-7328001	Bracket (quarter panel wheel cover guide)-front-LH	1	9L,0L	49-50
	1L-7228001	Bracket (quarter panel wheel opening cover)-front-LH	1	1L	51
	8H-7328002	Bracket (quarter panel wheel cover guide)-rear-RH	1	9H,0H,1H	49-51
	8L-7328002	Bracket (quarter panel wheel cover guide)-rear-RH	1	9L,0L	49-50
	1L-7228002	Bracket (quarter panel wheel opening cover)-rear-RH	1	1L	51
	8H-7328003	Bracket (quarter panel wheel cover guide)-rear-LH	1	9H,0H,1H	49-51
	8L-7328003	Bracket (quarter panel wheel cover guide)-rear-LH	1	9L,0L	49-50
	1L-7228003	Bracket (quarter panel wheel opening cover)-rear-LH	1	1L	51
	8L-7328006	Clip (quarter panel wheel cover reinforcement)-4" long	2	9L,0L,1L	49-51

# Hood

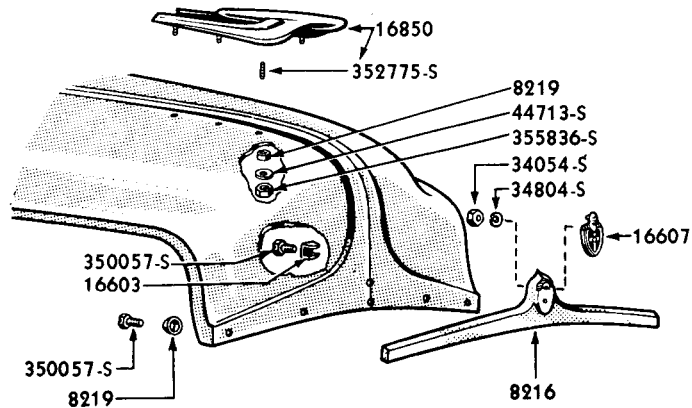

1949

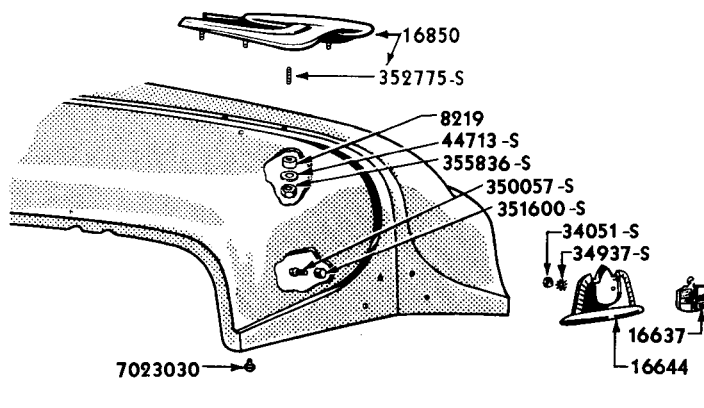

1950

PL-692

## 1949-50 HOOD ORNAMENTS

Basic numbers only shown on illustration. Order by Part Numbers shown in list of parts.

*Lincoln and Lincoln Cosmopolitan*  
CHASSIS PARTS CATALOGUE

Hood—Continued

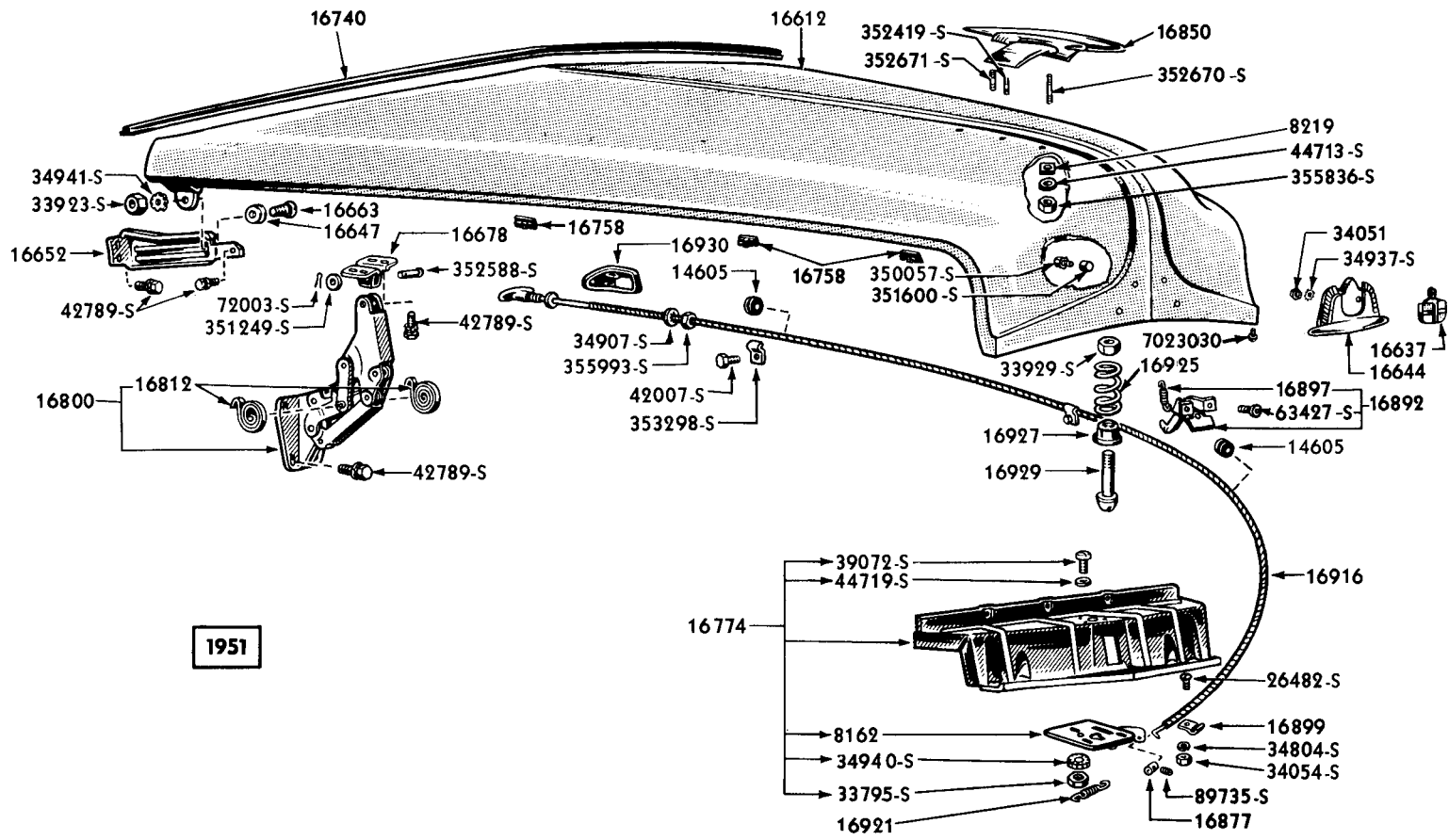

1951

**LINCOLN COSMOPOLITAN HOOD AND RELATED PARTS**

Basic numbers only shown on illustration. Order by Part Numbers shown in list of parts.

PL-665

Hood—Continued

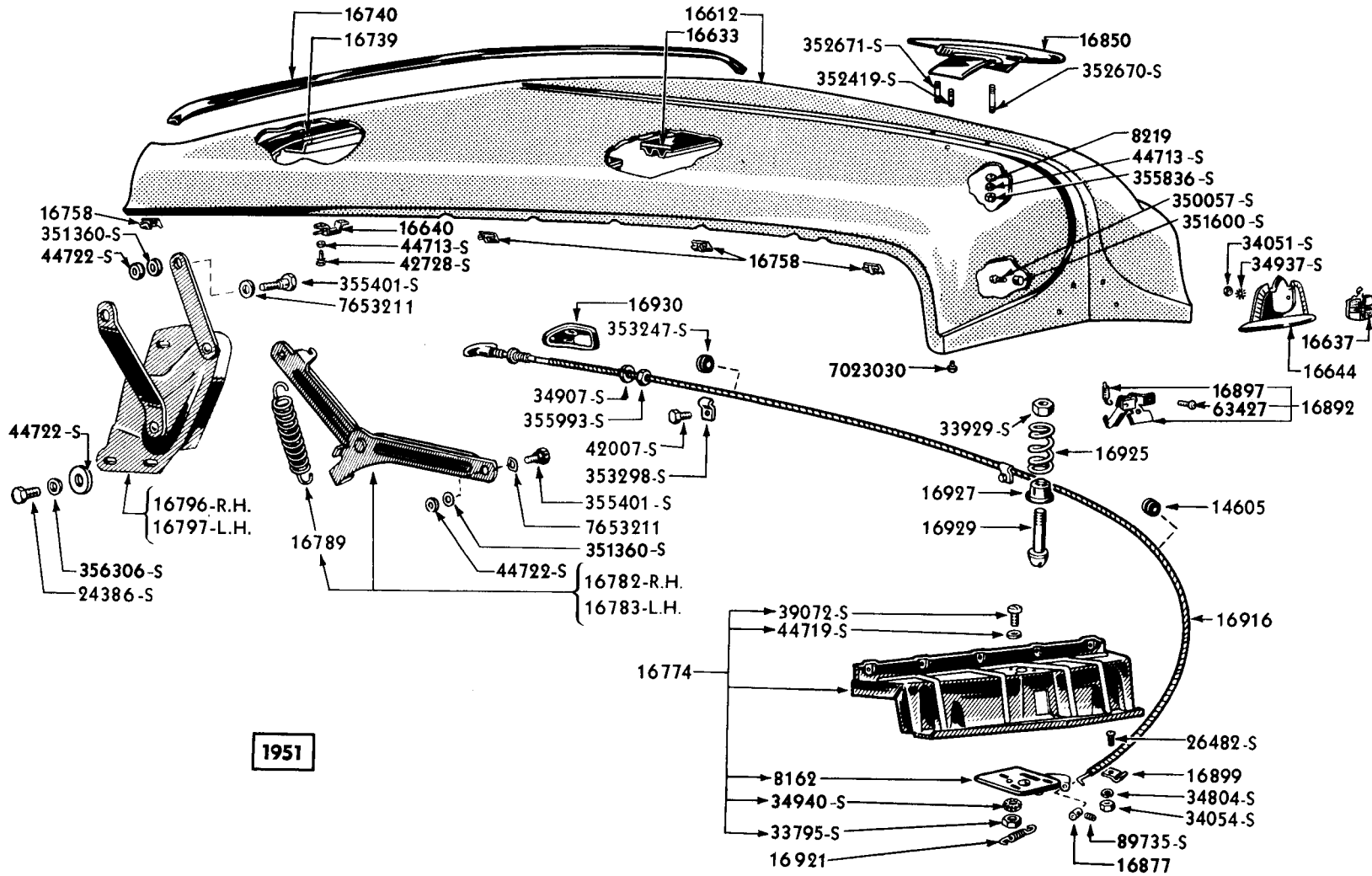

1951

PL-664

**LINCOLN HOOD AND RELATED PARTS**

Basic numbers only shown on illustration. Order by Part Numbers shown in list of parts.

# Lincoln and Lincoln Cosmopolitan

## CHASSIS PARTS CATALOGUE

PART NUMBER	PART NAME	NO. REQ'D	MODEL	YEAR 19
<b>Hood—Continued</b>				
8H 16603	Clip (hood ornament center)	2	9L,9H	49
	351600-S8 Washer (cup)-7/32" I.D. x 5/8" O.D. x 1/4" thick	2	9L,9H	49
5EH 16607	Emblem (radiator grille)	1	9L,9H	49
	34804-S8 Lockwasher-No. 12	1	9L,9H	49
	34054-S8 Nut (hex)-No. 12-24	1	9L,9H	49
	355862-S32 Nut (speed)-No. 14	5	9L,9H	49
	44716-S8 Washer (flat)-No. 12-emblem to hood	1	9L,9H	49
8H 16612-B	Hood assy	1	9H	49
8L 16612-A	Hood assy	1	9L	49
OH 16612-B	Hood assy-less ornament holes	1	OH,1H	50-51
1L 16612-B	Hood assy-less ornament holes	1	OL,1L	50-51
	11A-7023030-A Bumper (hood front to grille)-21/32" length	2	OL,OH,1L,1H	50-51
	11A-7023030-B Bumper (hood front to grille)-25/32" length	2	OL,OH,1L,1H	50-51
	44722-S8 Washer (flat)-5/16"-hood to roller guide	2	OH	50
8L 16633-B	Silencer (hood top panel to frt. strainer)-51" long	1	9L,OL,1L	49-51
OL 16637	Ornament (hood front and luggage compartment door)	2	OL,OH,1L,1H	50-51
	34051-S7 Nut (hex)-No. 6-32-ornament to retainer	2	OL,OH,1L,1H	50-51
	34937-S7 Lockwasher (external tooth)-No. 6-ornament to retainer	2	OL,OH,1L,1H	50-51
	351600-S8 Washer (cup)-3/16"-ornament to hood	2	OL,OH,1L,1H	50-51
1M 16640	Spacer assy (hood rear)	2	1L	51
	42728-S8 Screw and lockwasher (hex-hd)-No. 10-32 x 1/2"-spacer to hood reinforcement bracket	4	1L	51
	44713-S8 Washer (flat)-No. 10-spacer to hood reinforcement bracket	4	1L	51
OL 16644	Retainer (hood front ornament)	1	OL,OH,1L,1H	50-51
	350057-S7 Screw and washer assy (hex head)-No. 10-24 x 7/16"	4	OL,OH,1L,1H	50-51
7EH 16647	Roller (hood guide)-Brass	2	9H,OH,1H	49-51
	34941-S7 Lockwasher (external tooth)-5/16"-roller to hood roller guide	2	9H,OH,1H	49-51
	33923-S7 Nut (hex)-5/16"-24-roller to hood roller guide	2	9H,OH,1H	49-51
	44722-S8 Washer (flat)-5/16"-roller to hood roller guide	2	9H,OH,1H	49-51
8H 16652	Guide (hood roller)-RH	1	9H,OH,1H	49-51
8H 16653	Guide (hood roller)-LH	1	9H,OH,1H	49-51
	34443-S8 Locknut-5/16"-24	2	9H,OH,1H	49-51
	42789-S7 Screw and lockwasher (hex-hd)-5/16"-18 x 3/4"	6	9H,OH,1H	49-51
	88371-S Stud-5/16"-18 and 5/16"-24 x 1-1/4"	2	9H,OH,1H	49-51
	44724-S8 Washer (flat)-5/16"-guide to cowl panel	4	1H	51
	351359-S7 Washer (flat)-5/16"	2	9H,OH,1H	49-51



# Lincoln and Lincoln Cosmopolitan

## CHASSIS PARTS CATALOGUE

PART NUMBER	PART NAME	NO. REQ'D	MODEL	YEAR
<b>Hood—Continued</b>				
7EH 16663	Spindle (hood guide roller)	2	9H,OH,1H	49-51
7EH 16678	Bracket (hood hinge)-upper	2	9H,OH,1H	49-51
	352588-S7 Pin (clevis)-5/16" x 1-3/8"	2	9H,OH,1H	49-51
	352358-S Pin (self locking)-9/32" x 61/64"	2	9H,OH,1H	49-51
	42789-S7 Screw & washer assy (hex head)-5/16"-18 x 3/4"	8	9H,OH,1H	49-51
	44722-S8 Washer (flat)-5/16"	8	9H,OH,1H	49-51
	351249-S7 Washer (flat)-21/64" I.D. x 11/16" O.D.	2	9H,OH,1H	49-51
8H 16724-B	Medallion (front fender)-side-"Lincoln"	2	9H	49
8H 16724-C	Medallion (front fender)-side-"Cosmopolitan"	2	9H	49
OH 16724	Medallion (front fender side)-"Cosmopolitan"	2	OH,1H	50-51
8L 16724	Medallion (front fender)-side-"Lincoln"	2	9L	49
OL 16724	Medallion (front fender side)-"Lincoln"	2	OL,1L	50-51
	350786-AS7 Nut (spring)-No. 12	12 or 14	9L,9H,OL,OH,1L,1H	49-51
8M 16739-B	Anti rattler (hood rear reinforcement to hood)-48-1/4" long	1	9L,OL,1L	49-51
8H 16740-A	Pad (hood)-on cowl-60-1/2" long-straight sides	1	9H,OH	49-50
8M 16740-A	Pad (hood)-on cowl-54-1/2" long	1	9L,OL,1L	49-51
OH 16740	Pad (hood)-on cowl-60-1/2" long-concave sides	1	OH,1H	50-51
	351629-S28-A2B Drive nail-No. 6-pad to roof panel	8	9L,9H,OL,OH,1L,1H	49-51
99A 16758-A	Bumper (fender apron to frame)-Rubber	2	9L,9H,OL,OH,1L,1H	49-51
11A 16758-A	Bumper (glove compartment door)	2	OL,OH,1L,1H	50-51
7EH 16758	Bumper (hood side to hood top)-Rubber	10	9L,9H,OL,OH	49-50
OL 16758-B	Bumper (fender to hood)-5/32" high-Rubber	10	OL,OH,1L,1H	50-51
OL 16758-D	Bumper (fender to hood)-17/64" high-Rubber	10	OL,OH,1L,1H	50-51
7EH 16774	Support assy (hood latch)-7 slots 9/32" x 39/64"	1	9L,9H	49
OL 16774	Support assy (hood catch)-6 slots 9/32" x 39/64"	1	OL,OH	50
1L 16774	Support assy (hood latch)-8 slots 9/32" x 39/64"	1	1L,1H	51
	20384-S2 Bolt (hex)-1/4"-20 x 1"-support plate to upper grille bar	2	OL,OH	50
	34940-S2 Lockwasher (external tooth)-1/4"-support to upper grille bar	1	OL,OH	50
	34940-S2 Lockwasher (external tooth)-1/4"-support plate to upper grille bar	2	OL,OH	50
	33795-S7 Nut (hex)-1/4"-20-support to upper grille bar	1	OL,OH	50
	34129-S2 Nut (square)-1/4"-20	8	9L,9H,OL,OH	49-50
	355192-S8 Screw and washer (hex-hd)-1/4"-20 x 5/8"-support to air deflector	8	1L,1H	51
	44713-S8 Washer (flat)-1/4"-support to upper grille bar	2	OL,OH	50

# Lincoln and Lincoln Cosmopolitan

## CHASSIS PARTS CATALOGUE

PART NUMBER	PART NAME	NO. REQ'D	MODEL	YEAR
<b>Hood—Continued</b>				
8L 16782-C	Support assy (hood)-RH	1	9L,OL,LL	49-51
8L 16783-C	Support assy (hood)-LH	1	9L,OL,LL	49-51
	8M-7653211 Washer (spring)-29/64" I.D. x 3/4" O.D. x 5/64" thick-support to bracket and fender	4	9L,OL,LL	49-51
	355401-S8 Bolt (hex-hd)-5/16"-24 x 7/8"-support to hood hinge brkt.	2	9L,OL,LL	49-51
	355401-S8 Bolt (hex-hd)-5/16"-24 x 7/8"-support to fender bracket	2	9L,OL,LL	49-51
	34443-S8 Locknut-5/16"-24	2	9L,OL,LL	49-51
	44722-S8 Washer (flat)-5/16"-support to front fender	2	9L,OL,LL	49-51
	44722-S8 Washer (flat)-5/16"-support to hood hinge	2	9L,OL,LL	49-51
	351360-S7 Washer (flat)-5/16" I.D. x 3/4" O.D. x 1/32"	4	9L,OL,LL	49-51
8L 16789-B	Spring (hood support)-4-1/2" free length	2	9L,OL,LL	49-51
8M 16796	Link and bracket assy (hood hinge)-RH	1	9L,OL,LL	49-51
8M 16797	Link and bracket assy (hood hinge)-LH	1	9L,OL,LL	49-51
	24386-S8 Bolt (hex-hd)-5/16"-18 x 1"	6	9L,OL,LL	49-51
	44722-S8 Washer (flat)-5/16"-link and bracket to hood hinge	4	9L,OL,LL	49-51
	356306-S7 Washer (special serrated)-1-1/8" O.D. x 5/16" I.D.	6	9L,OL,LL	49-51
	356383-S7 Washer (spring)-29/64" I.D. x 3/4" O.D.-link and bracket to hood hinge	4	9L,OL,LL	49-51
7EH 16800	Hinge assy (hood)	2	9H,OH	49-50
OH 16800	Hinge assy (hood)	2	1H	51
	352588-S7-8 Pin (clevis)-5/16" x 1-3/8"-hinge to hood	2	1H	51
	42789-S7 Screw and washer assy (hex-hd)-5/16"-18 x 3/4"	8	9H,OH,1H	49-51
	44722-S8 Washer (flat)-5/16"-hinge to dash panel	8	9H,OH	49-50
	351359-S7-8 Washer (flat)-5/16"-9/64" x 1-1/8"-hinge to dash panel	8	1H	51
	44724-S8 Washer (flat)-5/16"-hinge to dash panel	8	1H	51
7EH 16812	Spring (hood hinge)	4	9H,OH	49-50
OH 16812	Spring (hood hinge)	4	1H	51
8H 16850	Ornament assy (hood)-top center	1	9H,OH	49-50
8L 16850	Ornament assy (hood)-top center	1	9L,OL	49-50
LL 16850	Ornament assy (hood)-top center	1	LL,1H	51
	8H-8219-B Spacer (hood ornament)-round	6	9L,9H,OL,OH	49-50
	8M-8219 Spacer (hood ornament)-square	2	LL,1H	51
	34053-S8 Nut (hex)-No. 10-24-ornament to hood	4 or 6	9L,9H,OL,OH,LL,1H	49-51
NS	352419-S8 Stud (screw)-No. 10-24 x 13/16"-ornament to hood	2	LL,1H	51
NS	352670-S8 Stud (screw)-No. 10-24 x 1-29/32"-ornament to hood	1	LL,1H	51

# Lincoln and Lincoln Cosmopolitan

## CHASSIS PARTS CATALOGUE

PART NUMBER	PART NAME	NO. REQ'D	MODEL	YEAR 19__
<b>Hood—Continued</b>				
NS	352671-S8 Stud (screw)-No. 10-24 x 1-1/2" -ornament to hood	1	1L, 1H	51
	352775-S34 Stud-No. 10-24 x 1"	6	9L, 9H, 0L, 0H	49-50
	44713-S8 Washer (flat)-No. 10-ornament to hood	4 or 6	9L, 9H, 0L, 0H, 1L, 1H	49-51
16H 16877-B	Sleeve (hood catch control cable)	1	9L, 9H, 0L, 0H, 1L, 1H	49-51
	89735-S18 Screw (headless set)-No. 12-28 x 1/4"	1	9L, 9H, 0L, 0H, 1L, 1H	49-51
7C 16884-B	Clevis (hood support spring)	1	9L, 0L, 1L	49-51
OL 16892	Hook assy (hood auxiliary catch)	1	0L, 0H, 1L, 1H	50-51
	34940-S2 Lockwasher (external tooth)- 1/4"-hook to hood inner panel	2	0L, 0H, 1L, 1H	50-51
	33795-S7 Nut (hex)-1/4"-20-hook assy to hood top panel	2	0L, 0H, 1L, 1H	50-51
	63427-S Rivet (oval head tubular)-3/16" x 1"	1	0L, 0H, 1L, 1H	50-51
	43263-S8 Screw and lockwasher assy (hex head)-1/4"-20 x 5/8"	2	0L, 0H, 1L, 1H	50-51
	44719-S8 Washer (flat)-1/4"-hook to hood inner panel	2	0L, 0H	50
	44720-S8 Washer (flat)-1/4"-hook to hood inner panel	2	1L, 1H	51
7EH 16896	Hook (hood auxiliary catch)	1	9L 9H	49
	63427-S Rivet (oval head tubular)-3/16" x 1"	1	9L, 9H	49
7EH 16897	Spring (hood auxiliary catch)-7 coils-close wound- 55/64" overall length	1	9H	49
OL 16897	Spring (hood auxiliary latch)-13 coils-1-5/32" overall length	1	0L, 0H, 1L, 1H	50-51
1L 16897	Spring (hood auxiliary catch)-13 coils-15/16" overall length	1	1L, 1H	51
16H 16899-A	Clip (hood lock cable)	1	9L, 9H, 0L, 0H, 1L, 1H	49-51
16H 16899-A	Clip (defroster control to air regulator control bracket)	1	0H, 1H	50-51
16H 16899-A	Clip (temperature control to air regulator control bracket)	1	0H	50
16H 16899-A	Clip (vent air control to bracket)	2	0H	50
	34054-S8 Nut (hex)-No. 12-24-clip to hood latch support	1	9L, 9H, 0L, 0H, 1L, 1H	49-51
	26482-S7 Screw (rd-hd)-No. 12-24 x 1/2"- clip to hood latch support	1	9L, 9H, 0L, 0H, 1L, 1H	49-51
	34604-S8 Washer (lock)-No. 12-clip to hood latch support	1	9L, 9H, 0L, 0H, 1L, 1H	49-51
8H 16916	Cable assy (hood catch control)-76" long	1	9H, 0H, 1H	49-51
8L 16916	Cable assy (hood catch control)-72" long	1	9L, 0L, 1L	49-51
	353298-S Clip (cable to fender apron)	2	9L, 9H, 0L, 0H, 1L, 1H	49-51
	353247-A1S Grommet (hood catch cable)- Rubber	1	9L, 0L, 1L	49-51
	355993-S7 Locknut (hex)-3/8"-24	1	9L, 9H, 0L, 0H, 1L	49-51
	34907-S7 Lockwasher (internal tooth)- 3/8"	1	9L, 9H, 0L, 0H, 1L, 1H	49-51

# Lincoln and Lincoln Cosmopolitan

## CHASSIS PARTS CATALOGUE

PART NUMBER	CUBIC FT	PART NAME	NO. REQ'D	MODEL	YEAR 19
-------------	----------	-----------	-----------	-------	------------

### Hood—Continued

		34804-S8 Lockwasher-No. 12-cable to hood reinforcement	1	9L,9H,OL,OH,1L,1H	49-51
		34054-S8 Nut (hex)-No. 12-24-cable to hood latch support	1	9L,9H,OL,OH,1L,1H	49-51
		42007-S7 Screw (hex head self tapping)-No. 10-12 x 1/2"	2	9L,9H,OL,OH,1L,1H	49-51
		89735-S8 Screw (set)-No. 12-28 x 1/4"-cable to cable catch	1	OL,1L	50-51
		C9A-14605 Grommet (hood release cable thru dash)	1	9L,9H,OL,OH,1L,1H	49-51
7EH 16921		Spring (hood latch trigger)	1	9L,9H,OL,OH,1L,1H	49-51
8H 16925		Spring (hood lock)	1	9L,9H,OL,OH,1L,1H	49-51
16H 16927		Guide (hood lock spring)	1	9L,9H,OL,OH,1L,1H	49-51
16H 16929-B		Dowel (hood lock)	1	9L,9H,OL,OH,1L,1H	49-51
		33929-S7 Nut (hex check)-1/2"-20	1	9L,9H,OL,OH,1L,1H	49-51
8H 16930		Bracket (hood control)-instrument panel	1	9H,OH,1H	49-51
8M 16930-C		Bracket (hood control)-instrument panel	1	9L except 76,OL,1L	49-51
8M 16930-D		Bracket (hood and top control)-instrument panel-with 15/64" diameter hole for top control	1	9L76	49
OM 16930		Bracket (hood and top control)-instrument panel-with 33/64" x 13/64" hole for top control	1	9L76	49
		350212-S7 Bolt and washer assy (hex-hd)-1/4"-20 x 5/8"	2	9L,9H,OL,OH,1L,1H	49-51
		34129-S2 Nut (plain)-1/4"-20	2	9H,OH,1H	49-51

### Tools

B 17005-A		Bag assy (tool)	1	9L,9H,OL,OH,1L,1H	49-51
51A 17035		Wrench (jack handle and wheel nut)	1	9L,9H,OL,OH,1L,1H	49-51
5EH 17080-B		Jack assy (bumper)-lever type	1	9H,OH,1H	49-51
6H 17080		Jack assy (bumper)-crank type	1	9L,9H,OL,OH,1L,1H	49-51
1H 17080-A		Jack assy (bumper)-two leg crank type	1	1L,1H	51

MEMO

Lined area for writing the memo content.

# Lincoln and Lincoln Cosmopolitan

## CHASSIS PARTS CATALOGUE

PART NUMBER	PART NAME	NO. REQ'D	MODEL	YEAR
<b>Speedometer</b>				
8L 17255-A	Speedometer assy	1	9L,9H	49
0L 17255-A	Speedometer assy	1	0L,0H,1L,1H	50-51
	8L-10856 Gasket (speedometer)-inner	1	9L,9H	49
	8L-10862 Bezel (speedometer and instrument cluster)	2	9L,9H	49
	8L-10880 Glass (speedometer)-4-9/32" O.D. and 3/32" thick	1	9L,9H	49
	8L-10895 Gasket (speedometer)-outer	1	9L,9H	49
	78-13466 Bulb (speedometer)-2 C.P.	1	9L,9H,0L,0H,1L,1H	49-51
	34079-S7 Nut (hex)-No. 10-32	3	0L,0H,1L,1H	50-51
	43377-S8 Screw and lockwasher assy (pan head)-No. 6-32 x 1/2"	5	9L	49
	37611-S7 Screw (fillister head pointed)-No. 10-32 x 1/4"	6	0L,0H,1L,1H	50-51

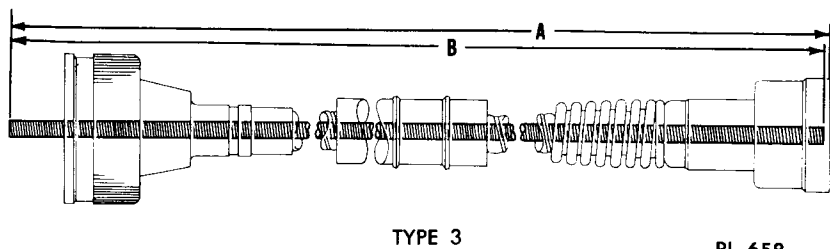
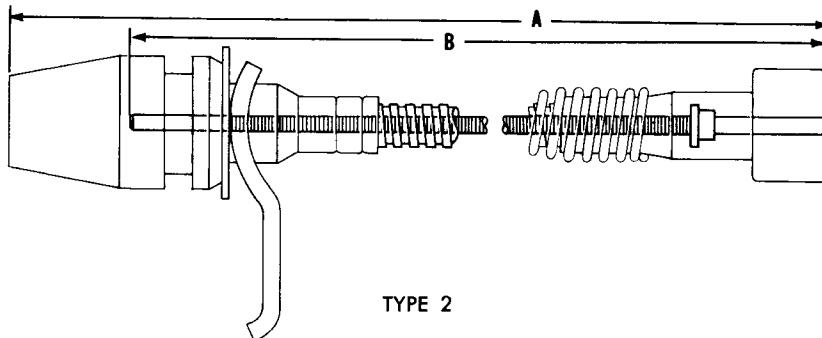
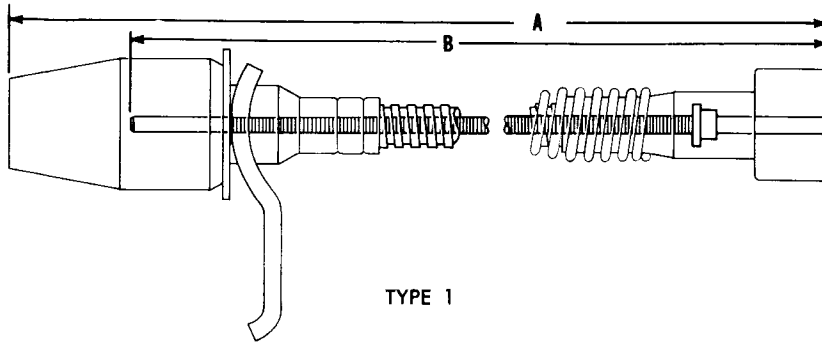

# Lincoln and Lincoln Cosmopolitan

## CHASSIS PARTS CATALOGUE

### Speedometer—Continued

#### SPEEDOMETER CASING AND SHAFT CHART

YEAR	MODEL	TYPE	CASING AND SHAFT ASSEMBLY			SHAFT ASSEMBLY		
			STANDARD	OVERDRIVE	AUTOMATIC	STANDARD	OVERDRIVE	AUTOMATIC
49	9H	1	8H-17260-A (A) 83-25/32"	8H-17260-A (A) 83-25/32"		8H-17262-A (B) 82-57/64"	8H-17262-A (3) 82-57/64"	
49	9H	3			8H-17260-B (A) 76-9/64"			8H-17262-B (B) 76-1/8"
49	9H	2	8H-17260-C (A) 83-25/32"	8H-17260-C (A) 83-25/32"		8H-17262-A (B) 82-57/64"	8H-17262-A (B) 82-57/64"	
49	9L	1	8L-17260-A (A) 77-25/32"	8L-17260-A (A) 77-25/32"		8L-17262-A (B) 76-57/64"	8L-17262-A (B) 76-57/64"	
49-51	9L,OH,1H	3			8L-17260-B (A) 71-9/64"			8L-17262-B" (B) 71-1/8'
49	9L	2	8L-17260-C (A) 77-25/32"	8L-17260-C (A) 77-25/32"		8L-17262-A (B) 76-57/64"	8L-17262-A (B) 76-57/64"	
50-51	OL,LL	3			OL-17260-B (A) 66-9/64"			OL-17262-B (B) 66-1/8"
50-51	OL,LL	2		OL-17260-C (A) 72-25/32"			OL-17262-A (B) 71-57/64"	
50-51	OH,1H	2		OH-17260-B (A) 78-25/32"			OH-17262-A (B) 77-57/64"	

PART NUMBER	QUANTITY	PART NAME	NO. REQ'D	MODEL	YEAR 19__
01T-14585		Clip (speedometer cable to frame)	2	9L,9H,OL,OH,LL,1H	49-51
24327-88		Bolt (hex-hd)-1/4"-20 x 5/8"-casing and shaft to transmission housing	1	9L,9H,OL,OH,LL,1H	49-51
352961-S		Grommet-7/32" x 7/8" x 7/16"-casing and shaft thru dash-Rubber	1	OL,OH,LL,1H	50-51
34805-S2		Lockwasher-1/4"-casing and shaft to trans. housing	1	9L,9H,OL,OH,LL,1H	49-51
86H 17264-A		Clip (front hand brake cable to frame)	1	9H,OH,1H	49-51
+8L 17269		Adapter (speedometer drive)	1	9L,9H,OL,OH,LL,1H	49-51
8M 17275		Gasket (speedometer gear bearing)-7/8" I.D. x 1-1/8" O.D. x 1/16" thick-use with Type "1" speedometer casing and shaft assy	1	9L,9H,OL,OH,LL,1H	49-51
8L 17285		Gear (speedometer driving)-7 teeth	1	9L,9H,OL,OH,LL,1H	49-51
		74172-S Key (woodruff)-No. 3	1	9L,9H,OL,OH,LL,1H	49-51
1A 17298		Seal (speedometer drive gear oil)-use with Type "2" speedometer casing and shaft assy	1	9L,9H,OL,OH,LL,1H	49-51

+ Used with HYDRA-MATIC transmission

# Lincoln and Lincoln Cosmopolitan

## CHASSIS PARTS CATALOGUE

PART NUMBER	PART NAME	NO. REQ'D	MODEL	YEAR 19__
<b>Speedometer—Continued</b>				
++OA 17322	Gear and shaft assy (speedometer)-19 teeth-use with 3.91 to 1 ratio rear axle	1	9L,9H,OL,OH,1L,1H	49-51
++8L 17322-B	Gear assy (speedometer driven)-21 teeth-Nylon-use with 4.27 to 1 ratio rear axle	1	9L,9H,OL,OH,1L,1H	49-51
+1L 17322-A	Gear assy (speedometer driven)-19 teeth-Steel-3.31 to 1 ratio rear axle	1	1L,1H	51
*8L 17322-C	Gear assy (speedometer driven)-16 teeth-used with 3.31 to 1 ratio rear axle-Steel	1	9L,9H,OL,OH,1L,1H	49-51
	24324-S7 Bolt (hex-hd)-1/4"-20 x 5/8"	1	9L,9H,OL,OH,1L,1H	49-51

## Rear Window Wiper

	EAK-18387-A Kit (rear window wiper installation)	1	OL,OH72-74,1H72-74	50-51
	1L-18387-A Kit (rear window wiper installation)	1	1L	51
8M 17402	Blade assy (rear window wiper)-curved glass	1	9L,9H, except 76	49
8H 17404-A	Motor assy (rear window wiper)	1	9H73	49
8H 17404-B	Motor assy (rear window wiper)	1	9H72-74	49
8M 17404	Motor assy (rear window wiper)	1	9L72-74	49
	34803-S7 Lockwasher-No. 10	2	9H	49
	351063-S13 Nut (slotted round)-3/8"-24- motor to body	1	9H73	49
	27145-S Screw (rd-hd)-No. 10-32 x 1"	2	9H	49
8H 17406	Arm assy (rear window wiper)	1	9H73	49
8M 17406	Arm assy (rear window wiper)	1	9L72-74,9H72-74	49
51A 17407	Control assy (rear window wiper)	1	9L,9H, except 76	49
51A 17408	Knob (rear window wiper control)	1	9L,9H, except 76	49
51A 17409	Driver assy (rear window wiper)	1	9H73	49
8M 17409	Driver assy (rear window wiper)	1	9L72-74,9H72-74	49
51A 17412-B	Hose (rear window wiper)-217" long-5/32" I.D. x 1 1/32" O.D.-Rubber	1	9H72-74	49
8H 17412	Hose (rear window wiper)-200" long-7/32" I.D. x 29/64" O.D.-Rubber	1	9H73	49
8M 17412	NS Hose (rear window wiper)-195" long-Rubber-cut from 8H-17412	1	9L72-74	49
51A 17413-C	Hose (rear window wiper)-217" long-7/32" I.D. x 29/64" O.D.-Rubber	1	9H72-74	49
8H 17413	Hose (rear window wiper)-200" long-7/32" I.D. x 29/64" O.D.-Rubber	1	9H73	49
8M 17413-A	Hose (rear window wiper)-40" long-Rubber	1	9L72-74,9H, except 76	49
8M 17413-B	NS Hose (rear window wiper)-195" long-cut from 8H-17413	1	9L72-74	49

+ Used with HYDRA-MATIC transmission

++ Not used with HYDRA-MATIC transmission



# Lincoln and Lincoln Cosmopolitan

## CHASSIS PARTS CATALOGUE

PART NUMBER	CLASS	PART NAME	NO. REQ'D	MODEL	YEAR 19 _____
-------------	-------	-----------	-----------	-------	------------------

### Rear Window Wiper—Continued

8M 17414-A		Spacer (rear window wiper)-inner	1	9L72-74	49
8H 17414-A		Spacer (rear window wiper motor to body)	1	9H73	49
8H 17414-B		Spacer (rear window wiper)-outer	1	9H72-74	49
8H 17414-C		Spacer (rear window wiper)-inner	1	9H72-74	49
51A 17415		Gasket (rear window wiper)-outer	1	9H73	49
51A 17416		Gasket (rear window wiper)-inner	1	9H73	49
51A 17417		Washer (rear window wiper cup)	1	9H73	49
		11C-17489 Connection (rear window wiper tee)	1	9L,9H, except 76	49

# Windshield Wiper

8M 17450	Plate and spring assy (W/S wiper)	1	9L,OL,1L	49-51
MAK 17464-A	Kit (universal W/S wiper arm)-consists of the following (1) 51A-17481 Nut (1) OL-17511 Driver (1) 51A-17511-A Driver (1) OL-17526 Arm (1) OL-17531 Clip (1) 51A-17585 Pin	as reqd	9L,OL,1L	49-51
8H 17470	Control assy (cable drive W/S wiper)-26-3/4" long	1	9H	49
OH 17470	Control assy (W/S wiper)-27-7/64" long	1	OH	50
1H 17470	Control assy (W/S wiper)-27-1/4" long	1	1H	51
8M 17470	Control assy (W/S wiper)-22-3/4" long	1	9L	49
OM 17470	Control assy (W/S wiper)-22-23/32" long	1	OL	50
1L 17470	Control assy (W/S wiper)-22-7/8" long	1	1L	51
	8L-7004658-A Tray assy (W/S wiper control)	1	9L,9H	49
	355993-S8 Locknut (hex)-3/8"-24-tray to instrument panel	1	9L,9H	49
	34907-S7 Lockwasher (internal tooth)-3/8"-tray to instr. panel	1	9L	49
	26479-S7 Screw (rd-hd)-No. 6-32 x 1/2"-control cable to wiper motor	1	9L,OL,1L	49-51
	36782-S7 Screw (rd-hd)-No. 6-32 x 1/4"-control cable to wiper motor	1	9H,OH,1H	49-51
	34701-S23 Washer (flat)-No. 6-control cable to wiper motor	1	9L,9H,OL,OH,1L,1H	49-51
OL 17482	Bezel (W/S wiper control)-2 slot center	1	OL,OH	50
1L 17482	Bezel (W/S wiper control)-4 slot center	1	1L,1H	51
11C 17489	Connection (W/S wiper tee)	1	9L,9H,OL,OH,1L,1H, except 76	49-51
11C 17489	Connection (rear window wiper tee)	1	9L,9H, except 76	49
8H 17508	Motor assy (cable drive W/S wiper)	1	9H,OH,1H	49-51
8M 17508	Motor assy (W/S wiper)-5" between mounting hole centers	1	9L,OL	49-50
OM 17508-B	Motor assy (W/S wiper)-5-7/8" between mounting hole centers	1	OL,1L	50-51
	352423-S Bushing-9/16"-Rubber-motor to arm and shaft	2	9L,OL,1L	49-51
	34803-S7 Lockwasher-No. 10-motor to dash panel	2	9H,OH,1H	49-51
	34141-S8 Nut (square)-No. 10-32-motor to dash panel	2	9H,OH,1H	49-51
	27145-S13 Screw (rd-hd)-No. 10-32 x 1"-motor to dash panel	2	9H,OH,1H	49-51

# Lincoln and Lincoln Cosmopolitan

## CHASSIS PARTS CATALOGUE

### Windshield Wiper—Continued

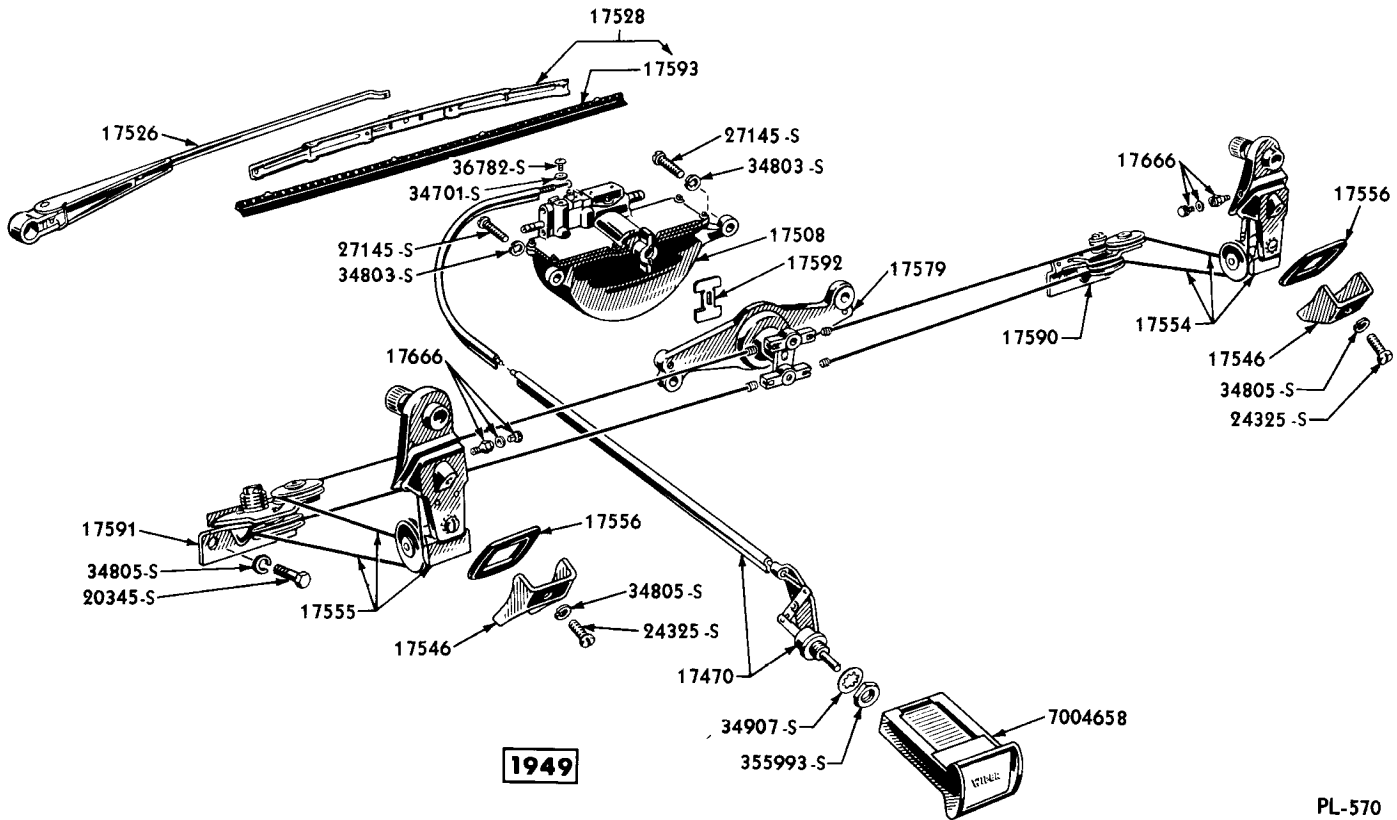

PL-570

## LINCOLN COSMOPOLITAN WINDSHIELD WIPER AND RELATED PARTS

Basic numbers only shown on illustration. Order by Part Numbers shown in list of parts.

PART NUMBER	QTY	PART NAME	NO. REQ'D	MODEL	YEAR
OL 17513		Knob assy (W/S wiper control)-with ribs	1	OL,OH	50
LL 17513		Knob assy (W/S wiper control)-with fins	1	LL,LH	51
		357324-S8 Screw (set)-No. 8-36 x 11/64"- knob to wiper knob shaft	1	LL,LH	51
8M 17515-A		Spacer (W/S wiper)-outer	2	9L	49
8M 17519		Spacer assy (W/S wiper mounting)-outer-RH	1	OL,LL	50-51
8M 17520		Spacer assy (W/S wiper mounting)-outer-LH	1	OL,LL	50-51
		356094-S13 Nut (octagon)-5/8"-24-spacer to roof panel	2	9L,OL,LL	49-51
06H 17522-A	NS	Hose (W/S wiper motor to vacuum booster)-Rubber-16" long-cut from 06H-17543-C	1	9H,OH,1H	49-51
06H 17522-A	NS	Hose (vacuum pump to intake manifold)-Rubber-16" long-cut from 06H-17543-C	1	9L,9H,OL,OH,LL,1H	49-51
		352963-S Grommet (Rubber)-1/4"-hose thru dash	1	9H,OH,1H	49-51
8H 17523		Gasket (W/S wiper cable drive)-cowl	1	9H,OH,1H	49-51
8H 17526-A		Arm assy (cable drive W/S wiper)	2	9H,OH,1H, except 76	49-51
8H 17526-B		Arm assy (cable drive W/S wiper)	2	9H76,OH76,1H76	49-51
OH 17526		Arm assy (W/S wiper)-adjustable-heavy duty	2	9L,9H,OL,OH,LL,1H	49-51

# Lincoln and Lincoln Cosmopolitan

## CHASSIS PARTS CATALOGUE

### Windshield Wiper—Continued

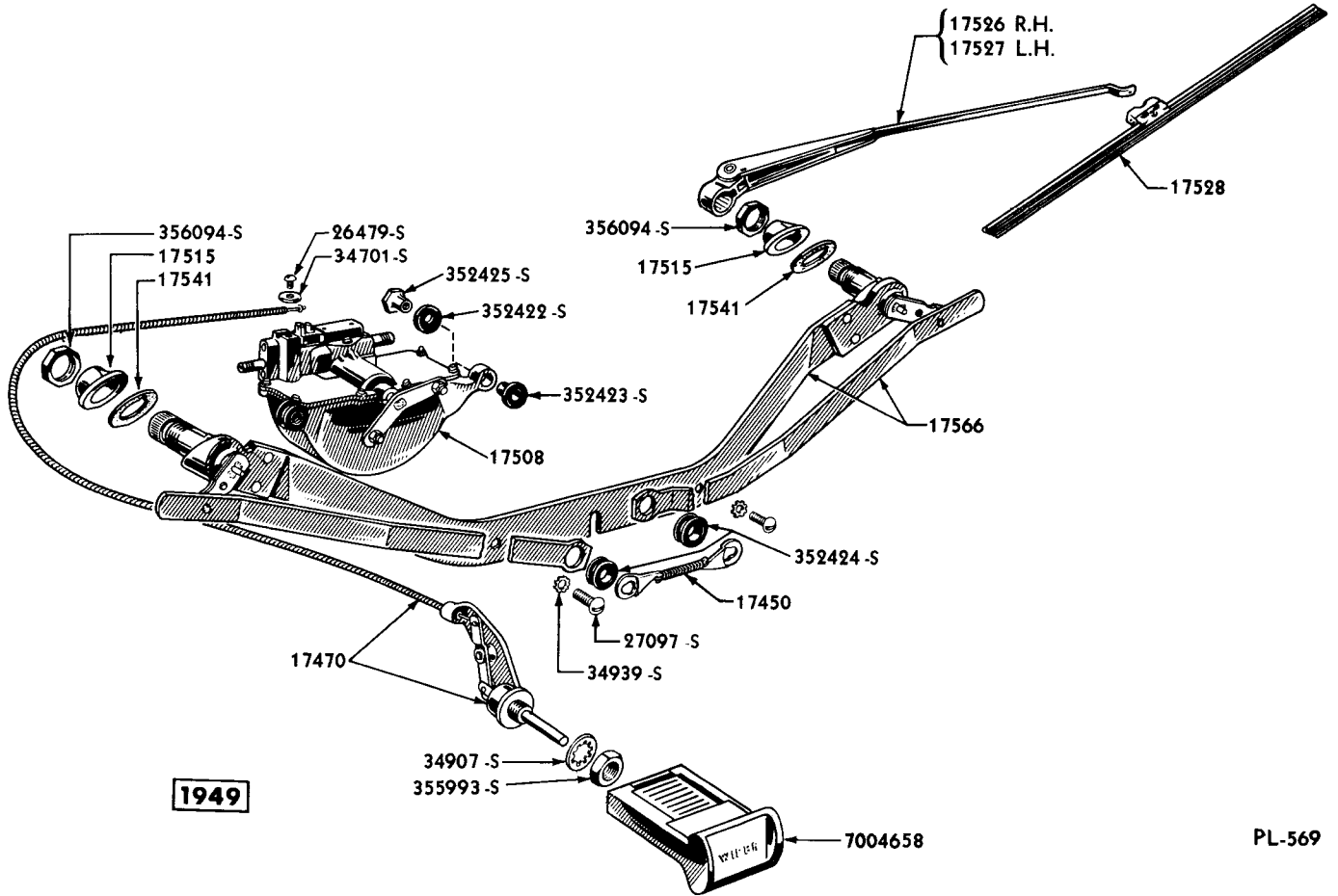

1949

PL-569

### LINCOLN WINDSHIELD WIPER AND RELATED PARTS

Basic numbers only shown on illustration. Order by Part Numbers shown in list of parts.

PART NUMBER	CLASS	PART NAME	NO. REQ'D	MODEL	YEAR 19
8H 17528-B		Blade assy (cable drive W/S wiper)	2	9L,9H,0L,0H,1L,1H	49-51
OH 17528		Blade assy (W/S wiper)-9"	2	9L,9H,0L,0H,1L,1H	49-51
		1H-17593 Insert assy (W/S wiper blade)-Rubber	2	9L,9H,0L,0H,1L,1H	49-51
MAK 17528-A		Kit (W/S wiper arm and blade display)-consists of the following (4) MAK-17464-A Kit (universal arm) (2) OH-17526 Arm (universal) (4) MAK-17528-B Blade (9" long for models prior to 1949) (12) MAK-17528-C Blade (11" long for Mercury only) (4) 8H-17528-B Blade (11" long for curved glass) (4) OH-17528 Blade (9" long) (2) 1H-17593 Insert	as req'd	9L,9H,0L,0H,1L,1H	49-51
8EL 17536		Tube assy (vacuum booster to W/S wiper hose)-Steel	1	9L,9H,0L,0H,1L,1H	49-51

# Lincoln and Lincoln Cosmopolitan

## CHASSIS PARTS CATALOGUE

### Windshield Wiper—Continued

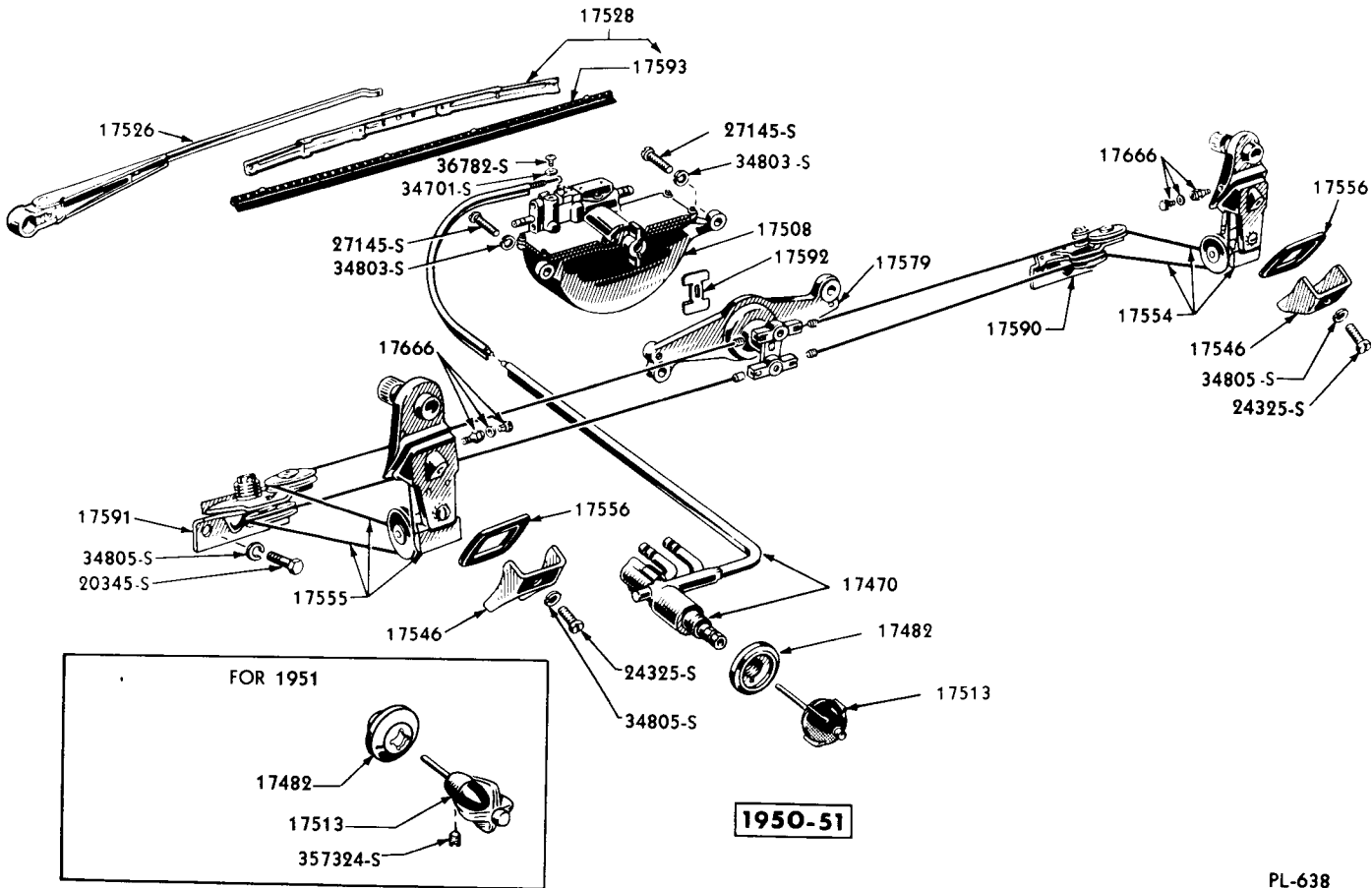

PL-638

### LINCOLN COSMOPOLITAN WINDSHIELD WIPER AND RELATED PARTS

Basic numbers only shown on illustration. Order by Part Numbers shown in list of parts.

PART NUMBER	QUANTITY	PART NAME	NO. REQ'D	MODEL	YEAR
8L 17541		Washer (pivot shaft mounting spacer)-outer-use when w/s washer nozzles are not part of pivot shaft mounting spacer	2	9L	1949
8M 17541-A		Washer (w/s wiper)-outer-Leather	2	9L	49
8M 17541-B		Washer (w/s shaft mounting spacer)-outer-use when w/s washer nozzles are part of pivot shaft mounting spacer	4	9L,OL,1L	49-51
06H 17543-C		Hose (w/s wiper)-25 ft. roll	as reqd	9L,9H,OL,OH,1L,1H	49-51
09A 17543-A	NS	Hose (w/s wiper)-31" long-Rubber-cut from 06H-17543-C	1	9L,OL,1L	49-51
		91A-14602-A Grommet (w/s wiper hose)	1	9L,OL,1L	49-51

# Lincoln and Lincoln Cosmopolitan

## CHASSIS PARTS CATALOGUE

### Windshield Wiper—Continued

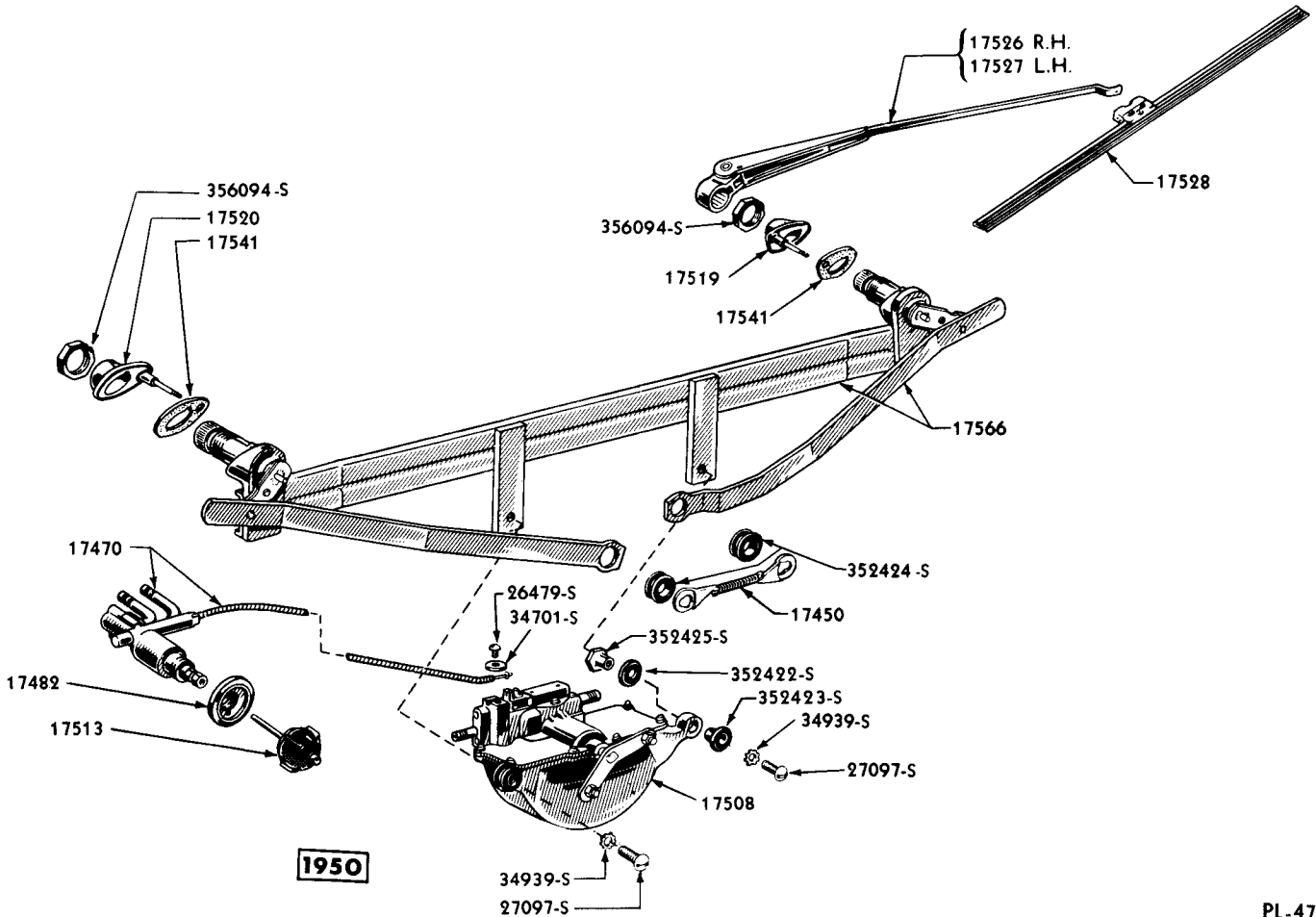

PL-470

## LINCOLN WINDSHIELD WIPER AND RELATED PARTS

Basic numbers only shown on illustration. Order by Part Numbers shown in list of parts.

PART NUMBER	UNIT	PART NAME	NO. REQ'D	MODEL	YEAR 19__
8H 17546		Bracket (cable drive W/S wiper clamp)	2	9H, OH, LH	49-51
		24325-S8 Bolt (hex-hd)-1/4"-28 x 5/8"- bracket to housing	2	9H, OH, LH	49-51
		34805-S2 Lockwasher-1/4"-bracket to hsg.	2	9H, OH, LH	49-51
8H 17554-A		Housing assy (cable drive W/S wiper pivot shaft)-RH -stamped "48L8H"	1	9H, OH, LH	49-51
8H 17554-B		Housing assy (cable drive W/S wiper pivot shaft)-RH -stamped "49L8H"	1	OH, LH	50-51
8H 17555-A		Housing assy (cable drive W/S wiper pivot shaft)-LH -stamped "48L8H"	1	9H, OH, LH	49-51
8H 17555-B		Housing assy (cable drive W/S wiper pivot shaft)-LH -stamped "49L8H"	1	OH, LH	50-51

# Lincoln and Lincoln Cosmopolitan

## CHASSIS PARTS CATALOGUE

### Windshield Wiper—Continued

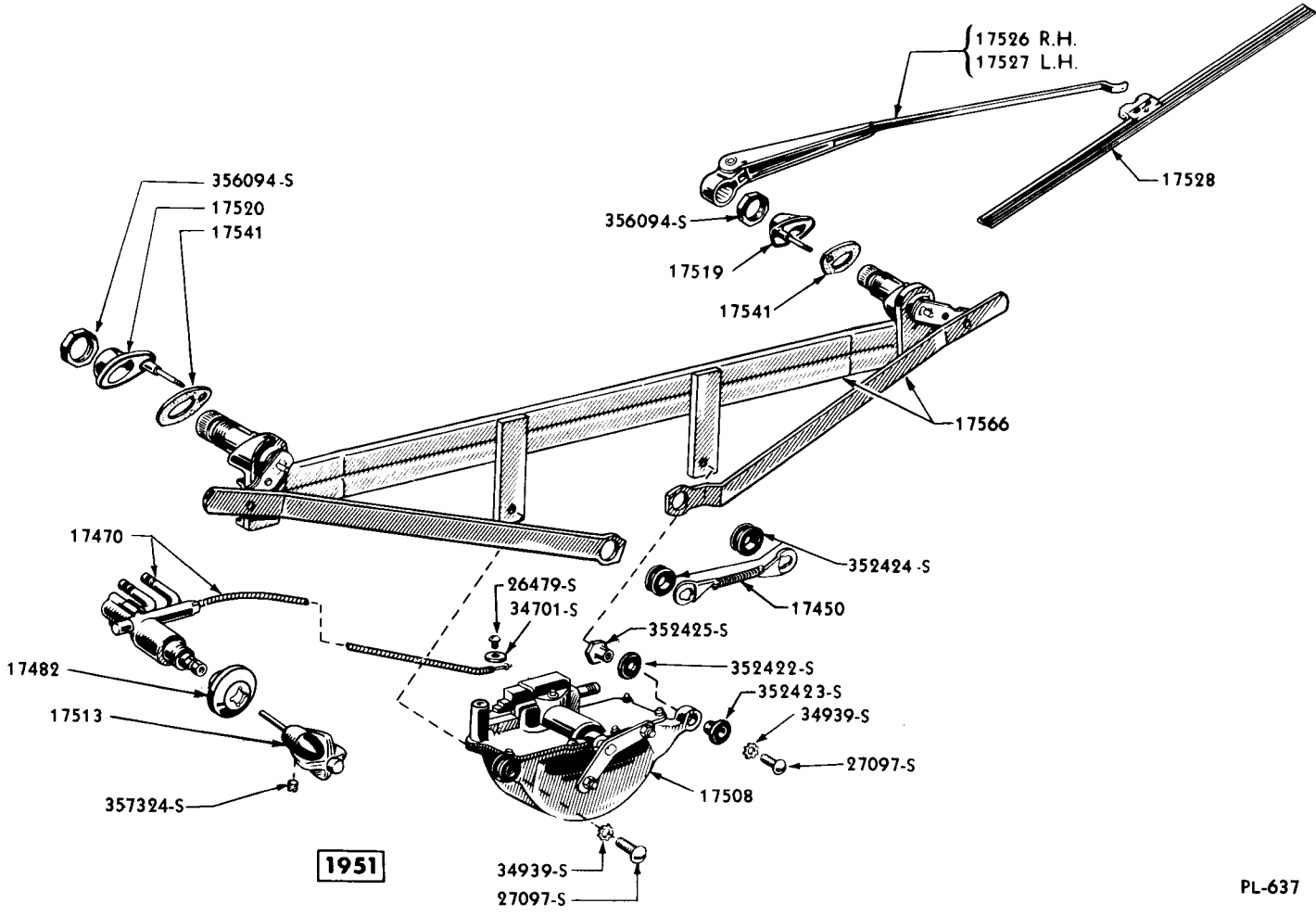

1951

PL-637

### LINCOLN WINDSHIELD WIPER AND RELATED PARTS

Basic numbers only shown on illustration. Order by Part Numbers shown in list of parts.

PART NUMBER	C O L O R	PART NAME	NO. REQ'D	MODEL	YEAR
					19
8H 17556		Gasket (cable drive W/S wiper)	2	9H,OH,1H	49-51
7C 17563-B		Anti squeak (W/S wiper motor to adapter)-Rubber	1	OH,1H	50-51
8M 17566		Arm and pivot shaft assy (W/S wiper mounting)	1	9L	49
OM 17566-A		Arm and pivot shaft assy (W/S wiper mounting)- 5" between motor mounting hole centers	1	OL	50
OM 17566-B		Arm and pivot shaft assy (W/S wiper mounting)-5-7/8" between motor mounting hole centers	1	OL,1L	50-51
		352425-S Eyelet (tapped)-No. 10-32-arm and shaft to wiper motor	2	9L,OL,1L	49-51
		352424-S Grommet (W/S wiper connecting arm)-Rubber	2	9L,OL,1L	49-51
		34903-S8 Lockwasher (internal tooth)-No. 10-arm and shaft to wiper motor	2	9L,OL,1L	49-51

# Lincoln and Lincoln Cosmopolitan

## CHASSIS PARTS CATALOGUE

PART NUMBER	PART NAME	NO. REQ'D	MODEL	YEAR
27097-S2	Screw (rd-hd)-No. 10-32 x 5/8" -arm and shaft to wiper motor	2	9L,OL,LL	49-51
352422-S	Washer (flat)-15/64" I.D. x 9/16" O.D.-arm and shaft to wiper motor	2	9L,OL,LL	49-51
*8H-17579	Body assy (W/S wiper auxiliary drive)-Zinc Die Cast	1	9H,OH,1H	49-51
*1H-17579	Body assy (W/S wiper auxiliary drive)-Stamped Steel	1	9H,OH,1H	49-51
8H-17590	Tensioner assy (cable drive W/S wiper)-RH	1	9H,OH,1H	49-51
8H-17591	Tensioner assy (cable drive W/S wiper)-LH	1	9H,OH,1H	49-51
20345-S2	Bolt (hex-hd)-1/4"-28 x 3/4"- tensioner to dash panel	4	9H,OH,1H	49-51
34805-S8	Lockwasher-1/4"-tensioner to dash panel	4	9H,OH,1H	49-51
33796-S7	Nut (hex)-1/4"-28-tensioner to dash panel	4	9H,OH,1H	49-51
7A-17592	Gasket (cable drive W/S wiper motor saddle)	1	9H,OH,1H	49-51

## Windshield Washer

NS	8L-19550-A	Solution (W/S washer)-6 oz.- replaced by 8L-19550-B	9L,9H,OL,OH,LL,1H	49-51
	8L-19550-B	Solution (W/S washer)-case-consists of (12) 6 oz. containers	9L,9H,OL,OH,LL,1H	49-51
NS	OH-18293	Kit (automatic W/S washer installa- tion)-consists of the following- service details (1) OM-17574 Reservoir (1) OH-17580 Hose (1) OH-17583 Hose (1) 51A-17587 Tee (1) 51A-17615 Fitting (1) OM-17642 Valve (1) OM-17664 Pump (2) 51A-17666 Jet (3) 8L-18954 Clamp (3) 32873-S8 Screw	9L,9H,OL,OH,LL,1H	49-51
5EH 17574		Reservoir and injector assy (W/S washer)	1 9L,9H	49
	5EH-17618	Jar (W/S washer)-Square-Glass	1 9L,9H	49
OM 17574	NS	Reservoir and injector assy (W/S washer)	1 OL,OH,LL,1H	50-51
	8M-17616	Cap and injector assy (W/S washer)	1 9L,9H,OL,OH	49-50
	8M-17618	Jar (W/S washer)-Round-Glass	1 9L,9H,OL,OH	49-50
	32873-S7	Screw (round head self tapping) -No. 10-12 x 3/4"	3 9L,9H,OL,OH,LL,1H	49-51
	8L-17541	Washer (pivot shaft mounting spacer)-outer-use when W/S washer nozzles are not part of pivot shaft mounting spacer	2 9L	49
	8M-17541-B	Washer (pivot shaft mounting spacer)-outer-use when W/S washer nozzles are part of pivot shaft mounting spacer	2 9L,OL,LL	49-51

\* Alternate material due to Material Emergency



# Lincoln and Lincoln Cosmopolitan

## CHASSIS PARTS CATALOGUE

PART NUMBER	PART NAME	NO. REQ'D	MODEL	YEAR
<b>Windshield Washer-Continued</b>				
*8H 17579	Body assy (W/S wiper auxiliary drive)-Zinc Die Cast	1	9H,OH,1H	49-51
*1H 17579	Body assy (W/S wiper auxiliary drive)-Stamped Steel	1	9H,OH,1H	49-51
51A 17580	NS Hose (W/S washer tee to nozzle)-18" long	2	9H	49
5EH 17580	Hose (W/S washer tee to nozzle)-12" long	2	9L	49
OH 17580	Hose (W/S washer)-side of pump to tee-40" long	1	OL,OH,1L,1H	50-51
8H 17583	Hose (W/S washer pump to tee)-Rubber-66" long	2	9L,9H	49
OH 17583	Hose (W/S washer)-tee to nozzle-140" long	1	OL,OH,1L,1H	50-51
	8L-18954 Clamp (W/S washer hose)	4 or 5	9L,9H,OL,OH,1L,1H	49-51
51A 17587	Tee assy (W/S washer)	1	9L,9H,OL,OH,1L,1H	49-51
8H 17590	Tensioner assy (cable drive W/S wiper)-RH	1	9H,OH,1H	49-51
8H 17591	Tensioner assy (cable drive W/S wiper)-LH	1	9H,OH,1H	49-51
7A 17592	Gasket (cable drive W/S wiper motor saddle)	1	9H,OH,1H	49-51
1H 17593	Filler assy (W/S wiper blade)-Rubber	2	9H,OH,1H	49-51
*51A 17615	Fitting (W/S washer)-"Y" type-Metal assy-alternate with 1H-17615	1	9L,9H,OL,OH,1L,1H	49-51
*1H 17615	Fitting (W/S washer)-"Y" type-Plastic-alternate with 51A-17615	1	9L,9H,OL,OH,1L,1H	49-51
8M 17616	Cover and injector assy (W/S washer)-used with 8M-17618 Jar	1	9L,9H,OL,OH	49-50
5EH 17618	Jar (W/S washer)-Square-Glass	1	9L,9H	49
8M 17618	Jar (W/S washer)-Round-Glass-used with 8M-17616 Cover	1	9L,9H,OL,OH	49-50
OM 17642	Valve assy (W/S washer pump)	1	9L,9H,OL,OH,1L,1H	49-51
OM 17664	Pump assy (W/S washer)	1	9L,9H,OL,OH,1L,1H	49-51
8L 17665	Nozzle and pivot mounting spacer (W/S washer)-RH	1	9L	49
51A 17666	Jet (W/S washer)	2	9L,9H,OL,OH,1L,1H	49-51

## Rear View Mirror

	1L-18400 Kit (rear view mirror installation) -inside-non glare-consists of (1) 1L-17700 with installation instructions	1	1L	51
	1H-18402-B Kit (rear view mirror installation) -outside-consists of the follow- ing (1) 1H-17682 Mirror (1) 1H-17710 Plate (1) 28442-S13 Screw (2) 32924-S8 Screw	1	1L,1H	51
	8H-18402 Mirror assy (rear view)-outside-RH	1	9H	49
	8H-18403 Mirror assy (rear view)-outside-LH	1	9H	49
1H 17682	NS Mirror assy (rear view)-outside-serviced in 1H-18402-B Kit	1	1L,1H	51
	28442-S13 Screw (oval head machine)-No. 8-32 x 1-3/4"-mirror to plate	1	1L,1H	51
OH 17684-A	Bracket assy (inside rear view mirror)	1	OH72-74,1H72-74	50-51
OH 17684-B	Bracket assy (inside rear view mirror)	1	OH76,1H76	50-51

\* Alternate material due to Material Emergency

# Lincoln and Lincoln Cosmopolitan

## CHASSIS PARTS CATALOGUE

PART NUMBER	W.D.P.C.	PART NAME	NO. REQ'D	MODEL	YEAR 19____
<b>Rear View Mirror—Continued</b>					
8H 17700-A		Mirror and bracket assy (rear view)-inside	1	9E except 76	49
8H 17700-B		Mirror and bracket assy (rear view)-inside	1	9H76	49
OH 17700-A		Mirror and bracket assy (rear view)-inside	1	OH except 72C-76	50
OH 17700-B		Mirror and bracket assy (rear view)-inside	1	OH76	50
OH 17700-C		Mirror and bracket assy (rear view)-inside	1	OH72C	50
8L 17700		Mirror and bracket assy (rear view)-inside	1	9L, 0L	49-50
LL 17700	NS	Mirror assy (rear view)-inside-non glare-serviced in LL-18400-Kit	1	LL	51
		26466-S6 Screw (rd-hd)-No. 6-32 x 3/8"- bracket to mirror back	2	9L, 9H, 0L, OH, LL	49-51
		52352-S13 Screw (cross recessed oval head self tapping)-No. 8-15 x 5/8"	1	OH76, 1H76	50-51
		52368-S23 Screw (cross recessed oval head self tapping)-No. 8-15 x 7/3"	1	9E, OH	49-50
		52376-S13 Screw (oval hd)-No. 8-15 x 1"- mirror and bracket to windshield reinforcement	1	OH72-74, 1H72-74	50-51
		52382-S13 Screw (oval head)-No. 8-15 x 1-1/4"-mirror and bracket to windshield reinforcement	2	OH, 1H	50-51
		350142-S13 Screw (cross recessed oval hd)- No. 10-32 x 1-3/8"	2	9E	49
1H 17710	NS	Plate (rear view mirror)-serviced in 1H-18402-B Kit	1	LL, 1H	51
		32924-S8 Screw (pan-hd self tapping)- No. 10-12 x 1/2"-plate to door panel	2	LL, 1H	51
1H 17711		Mirror assy (rear view)-inside-non glare	1	1H	51
		27723-S13 Screw (rd-hd)-No. 8-32 x 9/16"- mirror to bracket	2	1H	51

## Front Bumpers

8H 17729	Anti squeak (front bumper stone deflector end)-10" long	2	9L,9H,OL,OH,1L,1H	49-51
OH 17737	Stud (rear view mirror attaching)	1	OL,OH,1L,1H	50-51
8H 17744	Deflector assy (front bumper stone)	1	9L,9H	49
OL 17744	Deflector assy (front bumper stone)	1	OL,OH	50
1L 17744	Deflector assy (front bumper stone)	1	1L,1H	51
	43264-S8 Bolt (hex)-5/16"-10 x 7/8"-stone deflector to front fender	6	OL,OH,1L,1H	50-51
	353363-S32 Nut (speed)-5/16"-10	6	9L,9H,OL,OH,1L,1H	49-51
	31497-S7 Screw (hex head washer self tapping)-No. 14-10 x 1/2"-stone deflector to fender	6	9H	49
	42143-S8 Screw (hex washer head self tapping)-No. 14-10 x 3/4"-fender to stone deflector	6	9H	49
	OL-17818 Panel (front bumper stone deflector ornament)-RH	1	OL,OH	50
	1L-17818-B Panel (front bumper stone deflector ornament)-RH	1	1L,1H	51
	OL-17819 Panel (front bumper stone deflector ornament)-LH	1	OL,OH	50

# Lincoln and Lincoln Cosmopolitan

## CHASSIS PARTS CATALOGUE

### Front Bumpers—Continued

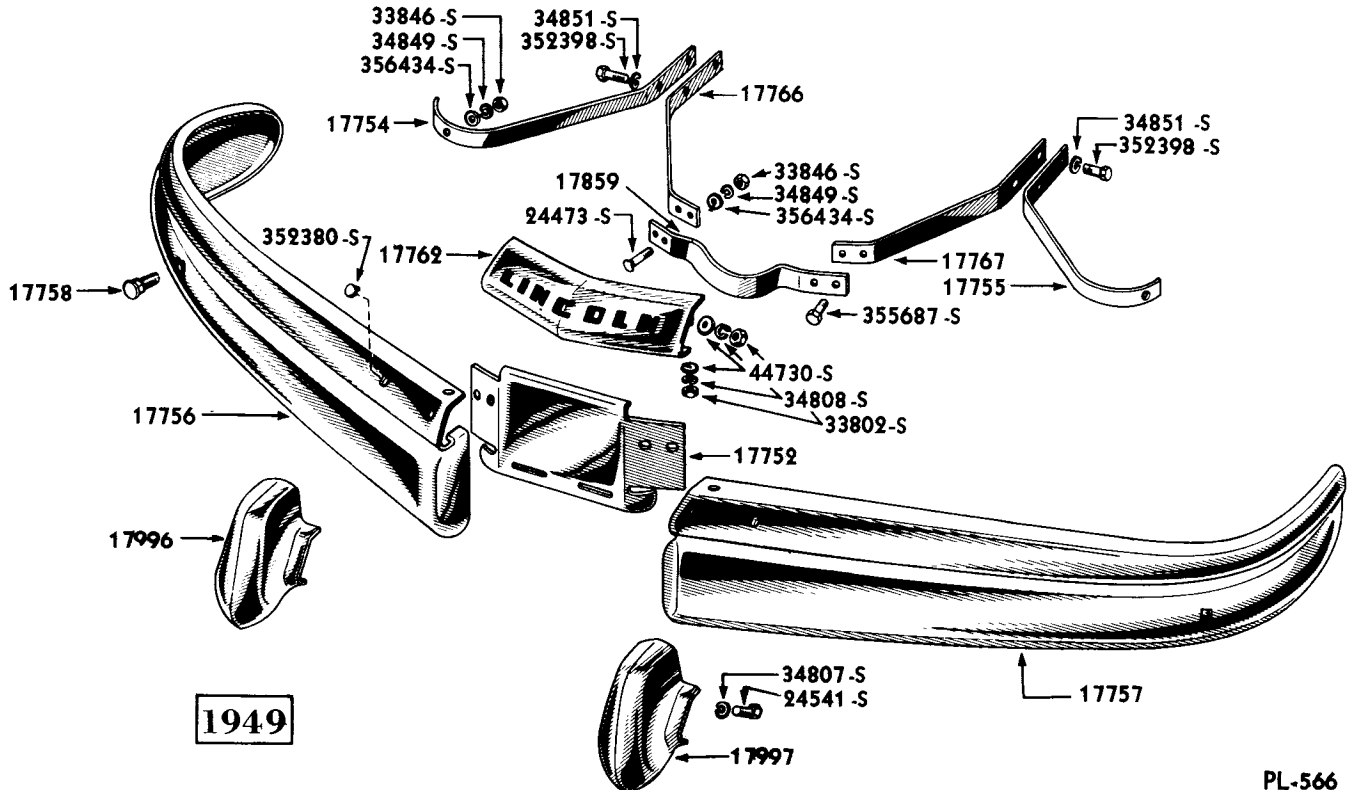

PL-566

### LINCOLN AND LINCOLN COSMOPOLITAN FRONT BUMPER AND RELATED PARTS

Basic numbers only shown on illustration. Order by Part Numbers shown in list of parts.

PART NUMBER	QUANTITY	PART NAME	NO. REQ'D	MODEL	YEAR
		LL-17819-B Panel (front bumper stone deflector ornament)-LH	1	1L,1H	51
		LL-17824-B Panel (front bumper stone deflector ornament end)-RH	1	1L,1H	51
		LL-17825-B Panel (front bumper stone deflector ornament end)-LH	1	1L,1H	51
		OL-17830 Cover (front bumper stone deflector)-center	1	OL,OH	50
		1L-17830-B Cover (front bumper stone deflector)-center	1	1L,1H	51
8H 17749		Anti rattler (front bumper arm to stone deflector)-3" long	4	9L,9H,OL,OH	49-50
1L 17749	NS	Anti rattler (front bumper arm to stone deflector)-2" long-use 8H-17749 for service	4	1L,1H	51
7EH 17752		Bar (center lower front impact)	1	9L,9H	49
OL 17752		Bar (front bumper center impact)	1	OL,OH	50
1L 17752		Bar assy (front bumper center impact)-lower	1	1L,1H	51
		355688-S8 Bolt (carriage)-1/2"-20 x 1-1/2"-bar to inner hanger	1	1L,1H	51
		357814-S Bumper (rubber)-bar to license plate	1	1L,1H	51

# Lincoln and Lincoln Cosmopolitan

## CHASSIS PARTS CATALOGUE

### Front Bumpers—Continued

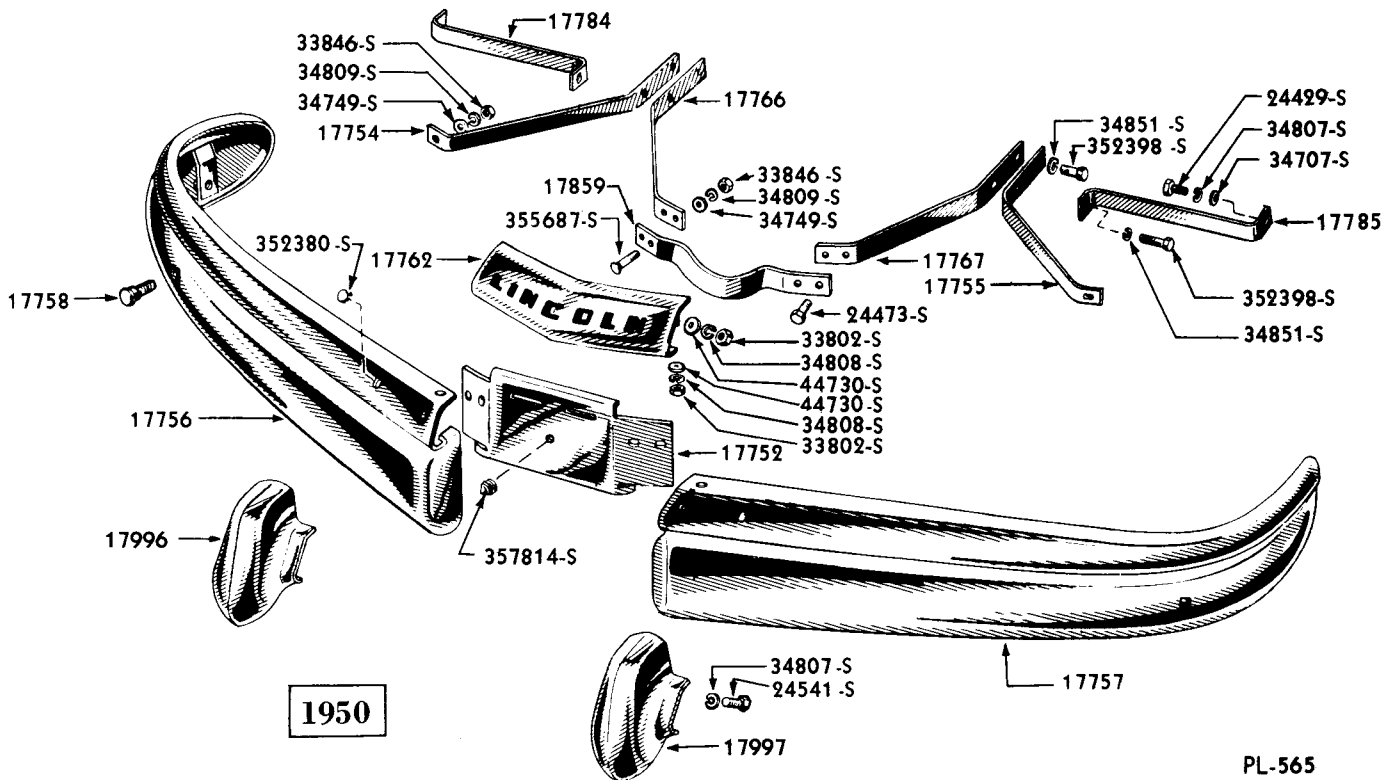

PL-565

### LINCOLN AND LINCOLN COSMOPOLITAN FRONT BUMPER AND RELATED PARTS

Basic numbers only shown on illustration. Order by Part Numbers shown in list of parts.

PART NUMBER	QUANTITY	PART NAME	NO. REQ'D	MODEL	YEAR 19
7EH 17754-B		Hanger (front bumper)-outer-RH-5 hole type	1	9L,9H	49
OL 17754		Hanger (front bumper)-outer-RH	1	OL,OH	50
1L 17754		Hanger (front bumper)-outer-RH	1	1L,1H	51
7EH 17755-B		Hanger (front bumper)-outer-LH-5 hole type	1	9L,9H	49
OL 17755		Hanger (front bumper)-outer-LH	1	OL,OH	50
1L 17755		Hanger (front bumper)-outer-LH	1	1L,1H	51
		352398-S8 Bolt (hex-hd)-5/8"-18 x 2"- hanger to frame	4	9L,9H,OL,OH,1L,1H	49-51
		34851-S7 Lockwasher-5/8"	4	9L,9H,OL,OH,1L,1H	49-51
		357295-S8 Screw (flat head)-1/2"-20 x 1-3/4"-hanger to bumper end brace	2	1L,1H	51
7EH 17756		Bar (front bumper impact)-RH	1	9L,9H	49
OL 17756		Bar assy (front bumper impact)-RH	1	OL,OH	50
1L 17756		Bar assy (front bumper impact)-RH	1	1L,1H	51
7EH 17757		Bar (front bumper impact)-LH	1	9L,9H	49
OL 17757		Bar assy (front bumper impact)-LH	1	OL,OH	50
1L 17757		Bar assy (front bumper impact)-LH	1	1L,1H	51
		7EH-17859 Reinforcement (center impact bar lower front bumper)	1	9L,9H	49
		OL-17859 Reinforcement (center impact bar lower front bumper)	1	OL,OH	50

# Lincoln and Lincoln Cosmopolitan

## CHASSIS PARTS CATALOGUE

PART NUMBER	PART NAME	NO. REQ'D	MODEL	YEAR
<b>Front Bumpers—Continued</b>				
	24473-S7 Bolt (hex-hd)-1/2"-20 x 1-1/2"	2	9L,9H,OL,OH	49-50
	355687-S7 Bolt (carriage)-1/2"-20 x 2"- impact bar to hanger	2	9L,9H,OL,OH	49-50
	355688-S8 Bolt (carriage)-1/2"-20 x 1-1/2"-bar to outer hanger	2	1L,1H	51
	355688-S8 Bolt (carriage)-1/2"-20 x 1-1/2"-bar to bumper end brace	2	1L,1H	51
	355688-S8 Bolt (carriage)-1/2"-20 x 1-1/2"-bar to inner hanger	2	1L,1H	51
	34849-S2 Lockwasher-1/2"	2	9L,9H,OL,OH	49-50
	34809-S8 Lockwasher-1/2"-bar to center impact bar	4	1L,1H	51
	34809-S8 Lockwasher-1/2"-bar to bumper end brace	2	1L,1H	51
	34809-S8 Lockwasher-1/2"-bar to outer hanger	2	9L,9H,OL,OH,1L,1H	49-51
	34809-S8 Lockwasher-1/2"-bar to inner hanger	2	9L,9H,OL,OH,1L,1H	49-51
	33846-S8 Nut (hex)-1/2"-20-bar to center impact bar	4	9L,9H,OL,OH,1L,1H	49-51
	33846-S8 Nut (hex)-1/2"-20-bar to outer hanger	2	9L,9H,OL,OH,1L,1H	49-51
	33846-S8 Nut (hex)-1/2"-20-bar to bumper end brace	2	1L,1H	51
	33846-S8 Nut (hex)-1/2"-20-bar to inner hanger	2	9L,9H,OL,OH,1L,1H	49-51
	44734-S8 Washer (flat)-1/4"-bar to outer hanger	2	9L,9H,OL,OH,1L,1H	49-51
	44734-S8 Washer (flat)-1/4"-bar to inner hanger	2	9L,9H,OL,OH,1L,1H	49-51
	44734-S8 Washer (flat)-1/4"-bar to bumper end brace	2	1L,1H	51
	356434-S7 Washer (flat)-17/32"	2	9L,9H,OL,OH	49-50
	8H-17996 Guard assy (front bumper)-RH	1	9L,9H,OL,OH	49-50
	1L-17996 Guard assy (front bumper)-RH	1	1L,1H	51
	8H-17997 Guard assy (front bumper)-LH	1	9L,9H,OL,OH	49-50
	1L-17997 Guard assy (front bumper)-LH	1	1L,1H	51
	20519-S2 Bolt (hex-hd)-1/2"-20 x 1-7/8"- guard to impact bar	4	OL,OH,1L,1H	50-51
	24541-S7 Bolt (hex-hd)-3/8"-24 x 2-3/8"- guard to impact bar	2	9L,9H,OL,OH	49-50
	34807-S2 Lockwasher-3/8"-guard to impact bar	2	9L,9H,OL,OH,1L,1H	49-51
	34809-S8 Lockwasher-1/2"-guard to impact bar	4	1L,1H	51
	33800-S8 Nut (hex)-3/8"-24-guard to center impact bar	2	1L,1H	51
	352380-S13 Plug (button)-25/32"-used when guards are omitted	2or4	9L,9H,OL,OH	49-50
26H 17758	Bolt (front and rear bumper bar to hanger)-1/2"-20 x 1-1/4"-capped	10	9L,9H,OL,OH,1L,1H	49-51
	34849-S2 Lockwasher-1/2"	10	9L,9H,OL,OH,1L,1H	49-51
	33846-S8 Nut (hex)-1/2"-20	10	9L,9H,OL,OH,1L,1H	49-51

# Lincoln and Lincoln Cosmopolitan

## CHASSIS PARTS CATALOGUE

### Front Bumpers—Continued

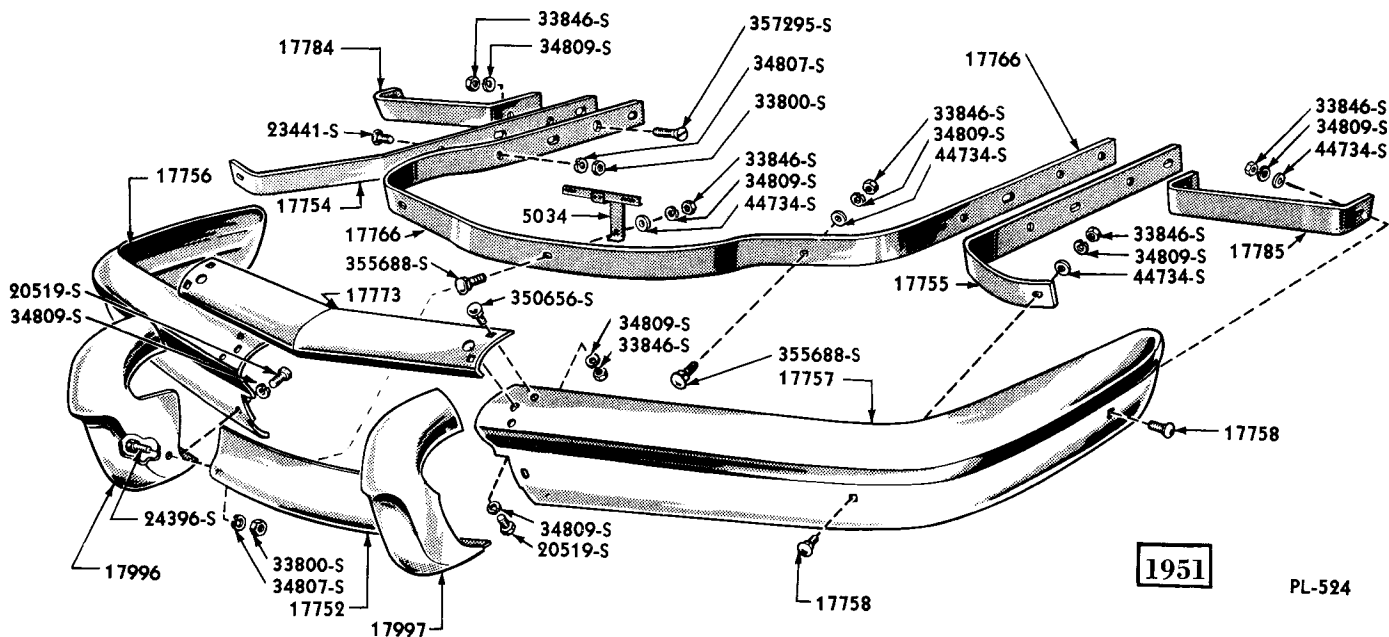

### LINCOLN AND LINCOLN COSMOPOLITAN FRONT BUMPER AND RELATED PARTS

Basic numbers only shown on illustration. Order by Part Numbers shown in list of parts.

PART NUMBER	QUANTITY	PART NAME	NO. REQ'D	MODEL	YEAR 19__
8L 17759		Spacer (guard to impact bar bolt)-13/32" I.D. x 13/16" O.D.	2	9L,OL	49-50
7EH 17762		Bar (front bumper impact)-upper	1	9L,9H,OL,OH	49-50
		34808-S8 Lockwasher-7/16"	4	9L,9H,OL,OH	49-50
		33802-S6 Nut (hex)-7/16"-20	4	9L,9H,OL,OH	49-50
		44730-S8 Washer (flat)-7/16"	4	9L,9H,OL,OH	49-50
7EH 17766-A		Hanger (front bumper)-inner-RH-3 hole type	1	9L,9H	49
7EH 17766-B		Hanger (front bumper)-inner-RH-5 hole type	1	9L,9H	49
OL 17766		Hanger (front bumper)-inner-RH	1	OL,OH	50
1L 17766		Hanger (front bumper)-inner	1	1L,1H	51
7EH 17767-A		Hanger (front bumper)-inner-LH-3 hole type	1	9L,9H	49
7EH 17767-B		Hanger (front bumper)-inner-LH-5 hole type	1	9L,9H	49
OL 17767		Hanger (front bumper)-inner-LH	1	OL,OH	50
		23441-S7 Bolt (rd-hd)-3/8"-24 x 1-1/4"-hanger to outer hanger	2	1L,1H	51
		24473-S7 Bolt (hex-hd)-1/2"-20 x 1-1/2"-hanger to front center lower impact bar	2	9L,9H,OL,OH	49-50
		352398-S8 Bolt (hex-hd)-5/8"-18 x 2"-hanger to frame	4	9L,9H,OL,OH, 1L, 1H	49-51
		33800-S8 Nut (hex)-3/8"-24-hanger to outer hanger	2	1L,1H	51

# Lincoln and Lincoln Cosmopolitan

## CHASSIS PARTS CATALOGUE

PART NUMBER	PART NAME	NO. REQ'D	MODEL	YEAR 19__
<b>Front Bumpers—Continued</b>				
	34807-S2 Lockwasher-3/8"-hanger to outer hanger	3	1L,1H	51
	34809-S8 Lockwasher-1/2"-hanger to bumper end brace	2	1L,1H	51
	34809-S8 Lockwasher-1/2"-hanger to center impact bar	1	1L,1H	51
	33846-S8 Nut (hex)-1/2"-20-hanger to brace bumper end	2	1L,1H	51
	33846-S8 Nut (hex)-1/2"-20-hanger to center impact bar	1	1L,1H	51
	44734-S8 Washer (flat)-1/4"-hanger to lower impact bar	1	1L,1H	51
1L 17773	Bar (front bumper center impact)-upper	1	1L,1H	51
	350656-S8 Bolt (carriage)-1/2"-20 x 1"-bar to outer impact bar	4	1L,1H	51
OL 17784	Brace (front bumper end to frame)-RH	1	OL,OH	50
1L 17784	Brace (front bumper end to frame)-RH	1	1L,1H	51
OL 17785	Brace (front bumper end to frame)-LH	1	OL,OH	50
1L 17785	Brace (front bumper end to frame)-LH	1	1L,1H	51
	24429-S7 Bolt (hex-hd)-3/8"-24 x 1-1/4"-brace to impact bar	2	OL,OH	50
	34807-S2 Lockwasher-3/8"	2	OL,OH	50
	34707-S2 Washer (flat)-3/8"	2	OL,OH	50

## Rear Bumpers

7EH 17786-B	Hanger (rear bumper)-inner-RH	1	9H,OH	49-50
7EH 17787-B	Hanger (rear bumper)-inner-LH	1	9H,OH	49-50
8L 17787	Hanger (rear bumper)-inner	2	9L,OL	49-50
1H 17787	Hanger (rear bumper)-inner	1	1H	51
1L 17787	Hanger (rear bumper)-inner-RH	1	1L	51
1L 17788	Hanger (rear bumper)-inner-LH	1	1L	51
	24433-S7-8 Bolt (hex-hd)-1/2"-20 x 1-1/4"-hanger to rear center lower impact bar	2	9H,OH	49-50
	24433-S7-8 Bolt (hex-hd)-1/2"-20 x 1-1/4"-hanger to impact bar end	2	9L,OL,1L	49-51
	24469-S7 Bolt (hex-hd)-3/8"-24 x 1-3/8"-hanger to outer hanger	2	9H,OH,1H	49-51
	24469-S7 Bolt (hex-hd)-3/8"-24 x 1-3/8"-hanger to bumper end brace	2	9L,OL,1L	49-51
	24473-S7 Bolt (hex-hd)-1/2"-20 x 1-1/2"-hanger to rear center lower impact bar	2	9L,9H	49
	34849-S2 Lockwasher-1/2"	2	9L,9H,OL,OH	49-50
	33846-S8 Nut (hex)-1/2"-20	2	9H,OH	49-50
	34370-S8 Nut (hex)-3/8"-24-hanger to bumper end brace	2	9L,OL,1L	49-51
	34370-S8 Nut (lock hex head)-3/8"-24-hanger to rear bumper outer hanger	4	9H,OH,1H	49-51
	44734-S8 Washer (flat)-1/2"-hanger to bumper guard	2	OL,1L	50-51
	356434-S7 Washer (flat)-17/32"	2	9H,OH	49-50



# Lincoln and Lincoln Cosmopolitan

## CHASSIS PARTS CATALOGUE

### Rear Bumpers—Continued

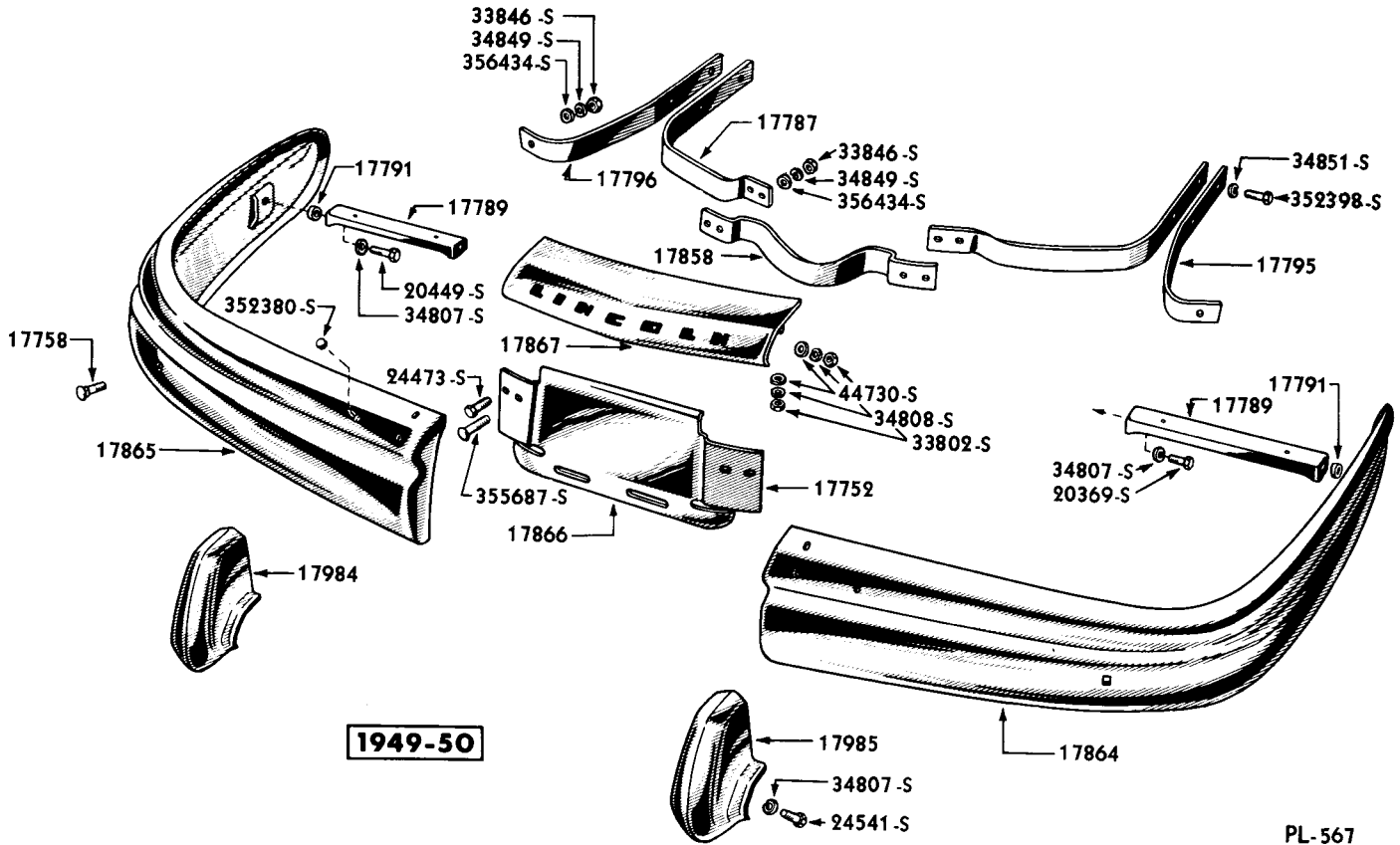

PL-567

### LINCOLN COSMOPOLITAN REAR BUMPER AND RELATED PARTS

Basic numbers only shown on illustration. Order by Part Numbers shown in list of parts.

PART NUMBER	QTY	PART NAME	NO. REQ'D	MODEL	YEAR
7EH 17789		Brace (rear bumper to frame)	2	9H,OH,1H	49-51
		20369-S2 Bolt (hex-hd)-3/8"-24 x 7/8"	2	9H,OH	49-50
		20449-S2 Bolt (hex-hd)-3/8"-24 x 1-3/8"	2	9H,OH	49-50
		24389-S8 Bolt (hex-hd)-3/8"-24 x 1"- brace to frame	2	1H	51
		34807-S2 Lockwasher-3/8"	4	9H,OH,1H	49-51
8L 17789		Brace (rear bumper end)	2	9L,OL	49-50
1L 17789		Brace (rear bumper end to frame)-RH	1	1L	51
1L 17790		Brace (rear bumper end to frame)-LH	1	1L	51
		24433-S7-8 Bolt (hex-hd)-1/2"-20 x 1-1/4"- brace to bumper end bar	2	9L,OL,1L	49-51
		33846-S8 Nut (hex)-1/2"-20-brace to bumper end bar	2	9L,OL,1L	49-51
		34829-S2 Lockwasher-1/2"-brace to bumper end bar	2	9L,OL,1L	49-51
		44734-S8 Washer (flat)-1/2"-brace to impact bar end	2	OL,1L	50-51

# Lincoln and Lincoln Cosmopolitan

## CHASSIS PARTS CATALOGUE

PART NUMBER	PART NAME	NO. REQ'D	MODEL	YEAR
<b>Rear Bumpers—Continued</b>				
7EH 17791	Spacer (rear bumper to frame brace)-27/64" I.D. x 29/32" O.D. x 13/32" thick	2	9H,OH	49-50
8H 17791	Spacer (rear bumper to frame brace)-27/64" I.D. x 29/32" O.D. x 5/16" thick	2	9H,OH,1H	49-51
7EH 17795-B	Hanger (rear bumper)-outer-RH	1	9H,OH	49-50
1H 17795	Hanger (rear bumper)-outer-RH	1	1H	51
8L 17795	Hanger (rear bumper)-outer	2	9L,OL	49-50
1L 17795	Hanger (rear bumper)-outer-RH	1	1L	51
7EH 17796-B	Hanger (rear bumper)-outer-LH	1	9H,OH	49-50
1H 17796	Hanger (rear bumper)-outer-LH	1	1H	51
1L 17796	Hanger (rear bumper)-outer-LH	1	1L	51
	352398-S8 Bolt (hex head)-5/8"-18 x 2"	4	9L,9H,OL,OH,1L,1H	49-51
	34849-S2 Lockwasher-1/2"	4	9L,9H,OL,OH,1L,1H	49-51
	34851-S7-8 Lockwasher-5/8"-hanger to frame	4	9L,9H,OL,OH,1L,1H	49-51
	33846-S8 Nut (hex)-1/2"-20	4	9L,9H,OL,OH,1L,1H	49-51
1L 17801-B	Deflector assy (rear bumper stone)	1	1L	51
	356115-S32 Nut (spring)-No. 14-deflector to fender	2	1L	51
	31498-S8 Screw (hex washer head)-No. 14-10 x 5/8"-deflector to fender	2	1L	51
	357206-S34 Screw (hex washer head)-No. 14-10 x 1/2"-deflector to quarter panel	2	1L	51
	357206-S34 Screw (hex washer head)-No. 14-10 x 1/2"-deflector to back panel	9	1L	51
	44719-S8 Washer (flat)-1/4"-deflector to fender	2	1L	51
8L 17804	Guard assy (rear bumper license plate)	1	9L,OL	49-50
8H 17808	Deflector (rear bumper stone)-center	1	9H,OH	49-50
8M 17808-A	Deflector (rear bumper stone)-upper-RH	1	9L,OL	49-50
1H 17808	Deflector (rear bumper stone)	1	1H	51
	24344-S7 Bolt (hex-hd)-1/4"-20 x 3/4"	4	9L,OL	49-50
	45017-S32 Nut (spring)-No. 10-12-deflector to back panel	12	1H	51
	357046-S32 Nut (spring)-No. 14-deflector to rear fender	4	OL	50
	31498-S8 Screw (hex washer head self tapping)-No. 14-10 x 5/8"-upper rear deflector to quarter panel	4	9L,OL	49-50
	31498-S8 Screw (hex washer head self tapping)-No. 14-10 x 5/8"-upper rear deflector to panel lower back	5	9L,OL	49-50
	42032-S8 Screw (hex washer head)-No. 10-12 x 3/4"-deflector to back panel	12	1H	51
	42143-S8 Screw (hex washer head)-No. 14-10 x 3/4"-deflector to rear fender	4	OL	50

# Lincoln and Lincoln Cosmopolitan

## CHASSIS PARTS CATALOGUE

### Rear Bumpers—Continued

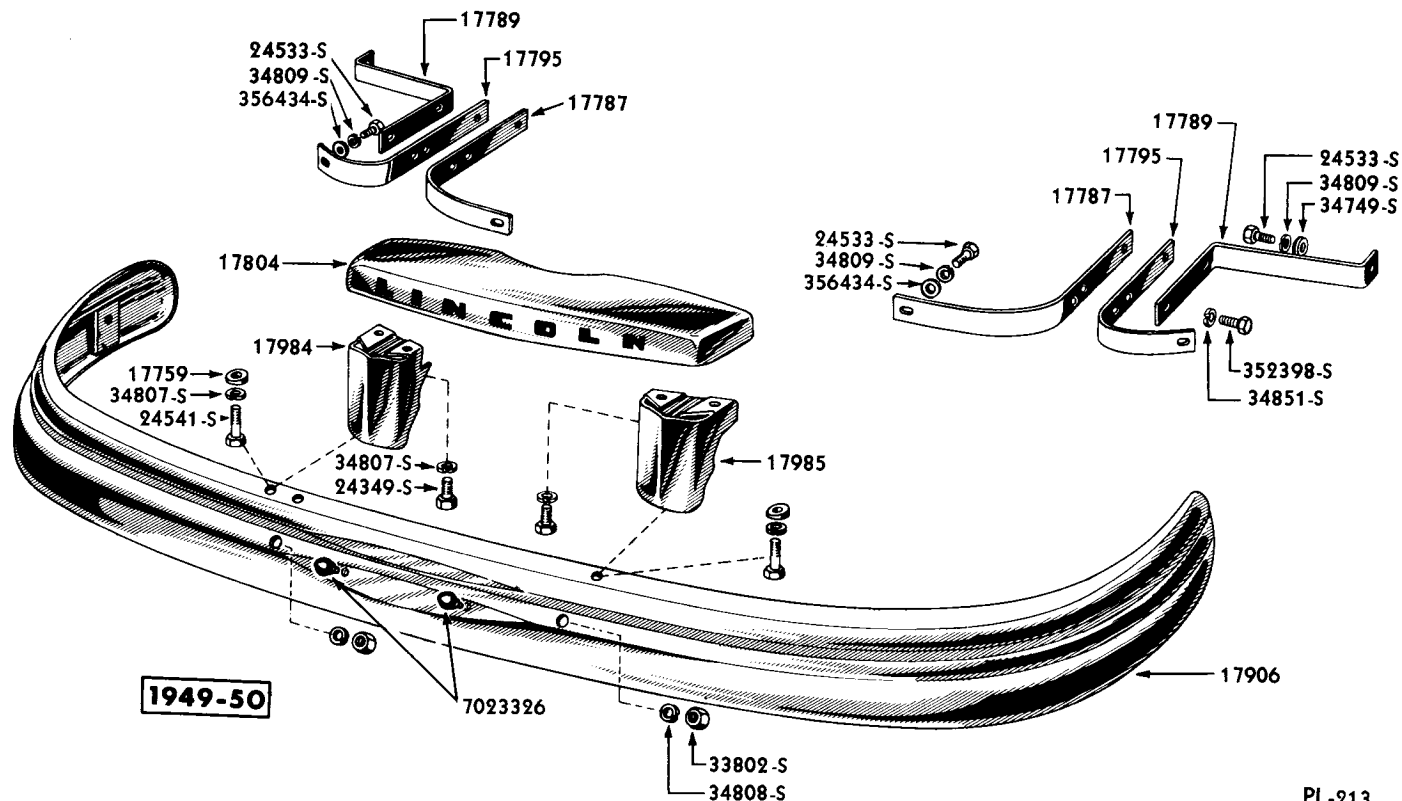

### LINCOLN REAR BUMPER AND RELATED PARTS

Basic numbers only shown on illustration. Order by Part Numbers shown in list of parts.

PART NUMBER	QUANTITY	PART NAME	NO. REQ'D	MODEL	YEAR
OL 17818		Panel (front bumper stone deflector ornament)-RH	1	OL,OH	19__
LL 17818-B		Panel (front bumper stone deflector ornament)-RH	1	LL,LH	50
OL 17819		Panel (front bumper stone deflector ornament)-LH	1	OL,OH	50
LL 17819-B		Panel (front bumper stone deflector ornament)-LH	1	LL,LH	51
		32917-S13 Screw (pan-hd self tapping)-No. 10-12 x 3/8"-end panel to stone deflector ornament panel	2	LL,LH	51
		42007-S8 Screw (hex head self tapping)-No. 10-12 x 1/2"	6	OL,OH	50
		52727-S13 Screw (cross recessed pan head self tap.)-No. 10-12 x 1/2"	4	OL,OH	50
LL 17824-A		Panel (front bumper stone deflector ornament end)-RH -Chrome	1	LL,LH	51
LL 17824-B		Panel (front bumper stone ornament end)-RH-Black	1	LL,LH	51
LL 17825-A		Panel (front bumper stone deflector ornament end)-LH -Chrome	1	LL,LH	51
LL 17825-B		Panel (front bumper stone ornament end)-LH-Black	1	LL,LH	51
		357033-S32 Nut (spring)-No. 10-panel to fender	6	LL,LH	51
		42014-S8 Screw (hex-hd)-No. 10-12 x 5/8"-panel to fender	6	LL,LH	51
		44719-S8 Washer (flat)-1/4"-panel to fender	6	LL,LH	51

# Lincoln and Lincoln Cosmopolitan

## CHASSIS PARTS CATALOGUE

PART NUMBER	PART NAME	NO. REQ'D	MODEL	YEAR 19__
<b>Rear Bumpers—Continued</b>				
OL 17830	Cover (front bumper stone deflector)-center	1	OL,OH	50
1L 17830-A	Cover (front bumper stone deflector)-center-Chrome	1	1L,1H	51
1L 17830-B	Cover (front bumper stone deflector)-center-Black	1	1L,1H	51
	45017-S32 Nut (spring)-No. 10-12-cover to stone deflector	2	OL,OH,1L,1H	50-51
	52345-S13 Screw (oval-hd)-No. 10-12 x 1/2"-cover to stone deflector	2	OL,OH,1L,1H	50-51
51A 17832-A	Extension (rear bumper stone deflector)-62" long- Rubber	1	9L,OL	49-50
1L 17832-B	Seal (rear bumper stone deflector)-center 80" long	1	1L	51
8H 17836	Deflector (rear stone)-outer-RH	1	9H	49
OH 17836	Deflector (rear stone)-outer-RH	1	OH	50
8L 17836	Deflector (rear fender stone)-side-RH	1	9L,OL	49-50
8H 17837	Deflector (rear stone)-outer-LH	1	9H	49
OH 17837	Deflector (rear stone)-outer-LH	1	OH	50
8L 17837	Deflector (rear fender stone)-side-LH	1	9L,OL	49-50
8H 17844-A	Extension (rear stone deflector)-outer-16" long- Rubber-used with 8H-17836-7	2	9H	49
OH 17844	Extension (rear stone deflector)-outer-Rubber-used with OH-17836-7	2	OH	50
7EH 17858	Reinforcement (rear bumper center bar)	1	9H,OH	49-50
	24473-S7 Bolt (hex-hd)-1/2"-20 x 1-1/2"	4	9H,OH	49-50
7EH 17859	Reinforcement (center impact bar lower front bumper)	1	9L,9H	49
OL 17859	Reinforcement (center impact bar lower front bumper)	1	OL,OH	50
	24473-S7 Bolt (hex-hd)-1/2"-20 x 1-1/2"	4	9L,9H	49
	355687-S7 Bolt (carriage)-1/2"-20 x 1-7/8"	2	9L,9H	49
7EH 17864	Bar (rear bumper impact)-RH	1	9H	49
OH 17864	Bar (rear bumper impact)-RH	1	OH	50
1H 17864	Bar (rear bumper impact)-RH	1	1H	51
1L 17864	Bar (rear bumper impact)-RH	1	1L	51
7EH 17865	Bar (rear bumper impact)-LH	1	9H	49
OH 17865	Bar (rear bumper impact)-LH	1	OH	50
1H 17865	Bar (rear bumper impact)-LH	1	1H	51
1L 17865	Bar (rear bumper impact)-LH	1	1L	51
	20449-S2 Bolt (hex-hd)-3/8"-24 x 1-3/8"	1	9H,OH	49-50
	34807-S2 Lockwasher-3/8"	1	9H,OH	49-50
	34829-S2 Lockwasher-1/2"-bar to center impact bar	2	1L,1H	51
	34829-S2 Lockwasher-1/2"-bar to outer hanger	4	1L,1H	51
	34829-S2 Lockwasher-1/2"-bar to inner hanger	2	1L,1H	51
	352380-S13 Plug (button)-use when bumper guards are omitted	4	9H,OH	49-50
	44734-S8 Washer (flat)-1/2"-bar to outer hanger	4	1L,1H	51
	44734-S8 Washer (flat)-1/2"-bar to inner hanger	2	1L,1H	51

# Lincoln and Lincoln Cosmopolitan

## CHASSIS PARTS CATALOGUE

### Rear Bumpers—Continued

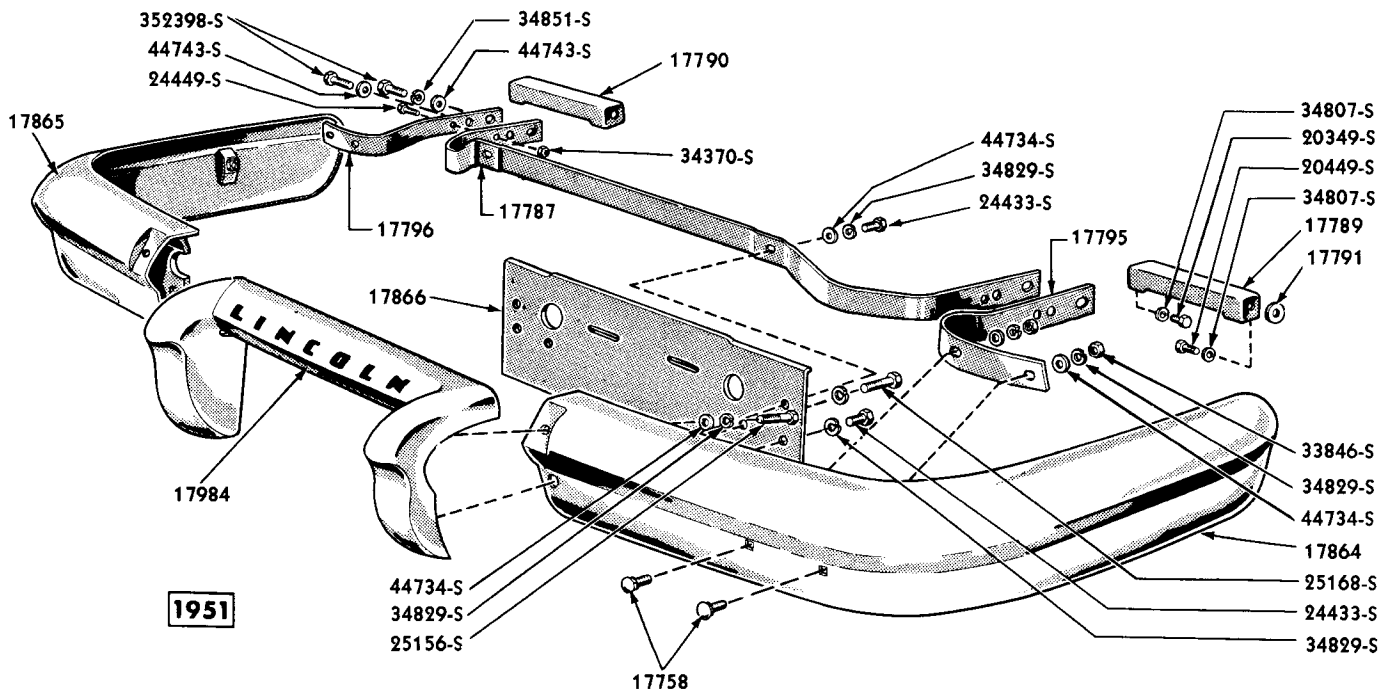

PL-532

### LINCOLN COSMOPOLITAN REAR BUMPER AND RELATED PARTS

Basic numbers only shown on illustration. Order by Part Numbers shown in list of parts.

PART NUMBER	C L S I F I C A T I O N	PART NAME	NO. REQ'D	MODEL	YEAR 19
7EH 17866		Bar (rear bumper center impact)-lower	1	9H,OH	49-50
1L 17866		Bar (rear bumper center impact):	1	1L,1H	51
		24473-S7 Bolt (hex-hd)-1/2"-20 x 1-1/2"	2	9H,OH	49-50
		24433-S7-8 Bolt (hex-hd)-1/2"-20 x 1-1/4" -bar to impact bar end	2	1L	51
		357814-S Bumper (rubber)-bar to license plate	1	1L,1H	51
		44734-S8 Washer (flat)-1/2"-bar to impact bar end	2	0L,1L	50-51
7EH 17867		Bar (rear bumper center impact)-upper	1	9H,OH	49-50
		34808-S8 Lockwasher-7/16"	4	9H,OH	49-50
		33802-S8 Nut (hex)-7/16"-20	4	9H,OH	49-50
		44730-S8 Washer (flat)-7/16"	4	9H,OH	49-50

# Lincoln and Lincoln Cosmopolitan

## CHASSIS PARTS CATALOGUE

PART NUMBER	PART NAME	NO. REQ'D	MODEL	YEAR 19
<b>Rear Bumpers—Continued</b>				
8H 17879	Retainer (rear bumper stone deflector)-center- 17-1/4" long	1	9H,OH	49-50
8L 17879	Retainer (rear bumper stone deflector extension)	1	9L,OL	49-50
8H 17881	Retainer (rear stone deflector)-outer-2-1/4" long	2	9H,OH	49-50
8L 17906	Bar assy (rear bumper impact)	1	9L,OL	49-50
5EH 17940	Tire inflator and fire extinguisher assy	1	9L,9H,OL,OH,1L,1H	49-51
8H 17984	Guard assy (rear bumper)-RH	1	9H,OH	49-50
8L 17984	Guard assy (rear bumper)-RH	1	9L,OL	49-50
1L 17984	Guard assy (rear bumper)	1	1L,1H	51
8H 17985	Guard assy (rear bumper)-LH	1	9H,OH	49-50
8L 17985	Guard assy (rear bumper)-LH	1	9L,OL	49-50
	24349-S7 Bolt (hex-hd)-3/8"-24 x 3/4"- guard to license plate guard	2	9L,9H,OL,OH	49-50
	24433-S7-8 Bolt (hex-hd)-1/2"-20 x 1-1/4" -guard to inner hanger	2	1H	51
	24433-S7-8 Bolt (hex-hd)-1/2"-20 x 1-1/4" -guard to center impact bar	2	1H	51
	24511-S7 Bolt (hex-hd)-1/2"-20 x 1-3/4"- guard to rear bumper	2	9H,OH	49-50
	24541-S7 Bolt (hex-hd)-3/8"-24 x 2-1/4"- guard to impact bar	4	9L,9H,OL,OH	49-50
	25156-S8 Bolt (hex-hd)-1/2"-20 x 2-5/8"- guard to impact bar end	2	1L,1H	51
	25164-S8 Bolt (hex-hd)-1/2"-20 x 3-1/2"- guard to impact bar	2	1H	51
	25168-S8 Bolt (hex-hd)-1/2"-20 x 4"- guard to impact bar center	2	1L	51
	34807-S2 Lockwasher-3/8"-guard to impact bar	4	9L,9H,OL,OH	49-50
	34809-S8 Lockwasher-1/2"	4	9L,9H,OL,OH	49-50
	34829-S2 Lockwasher-1/2"-guard to center impact bar	2	1L,1H	51
	34829-S2 Lockwasher-1/2"-guard to impact bar end	2	1L,1H	51
	44734-S8 Washer (flat)-1/2"-guard to impact bar end	2	1L,1H	51
8H 17996	Guard assy (front bumper)-RH	1	9L,9H,OL,OH	49-50
1L 17996	Guard assy (front bumper)-RH	1	1L,1H	51
8H 17997	Guard assy (front bumper)-LH	1	9L,9H,OL,OH	49-50
1L 17997	Guard assy (front bumper)-LH	1	1L,1H	51

# Lincoln and Lincoln Cosmopolitan

## CHASSIS PARTS CATALOGUE

### Rear Bumpers—Continued

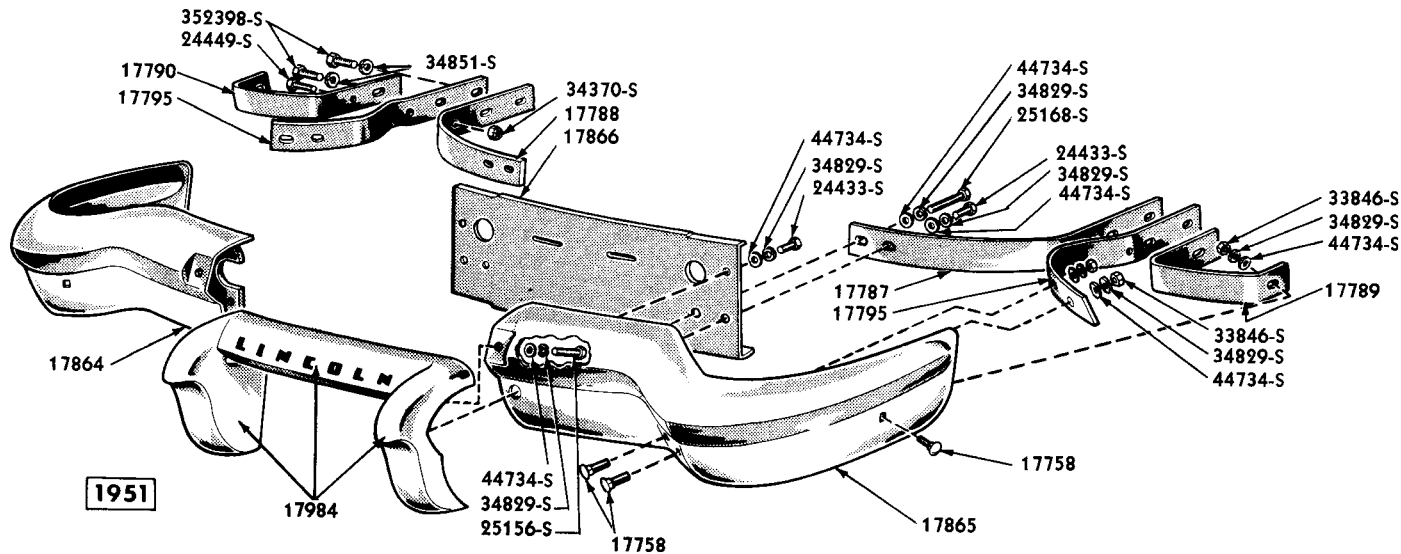

PL-523

### LINCOLN REAR BUMPER AND RELATED PARTS

Basic numbers only shown on illustration. Order by Part Numbers shown in list of parts.

# Lincoln and Lincoln Cosmopolitan

## CHASSIS PARTS CATALOGUE

### Rear Bumpers—Continued

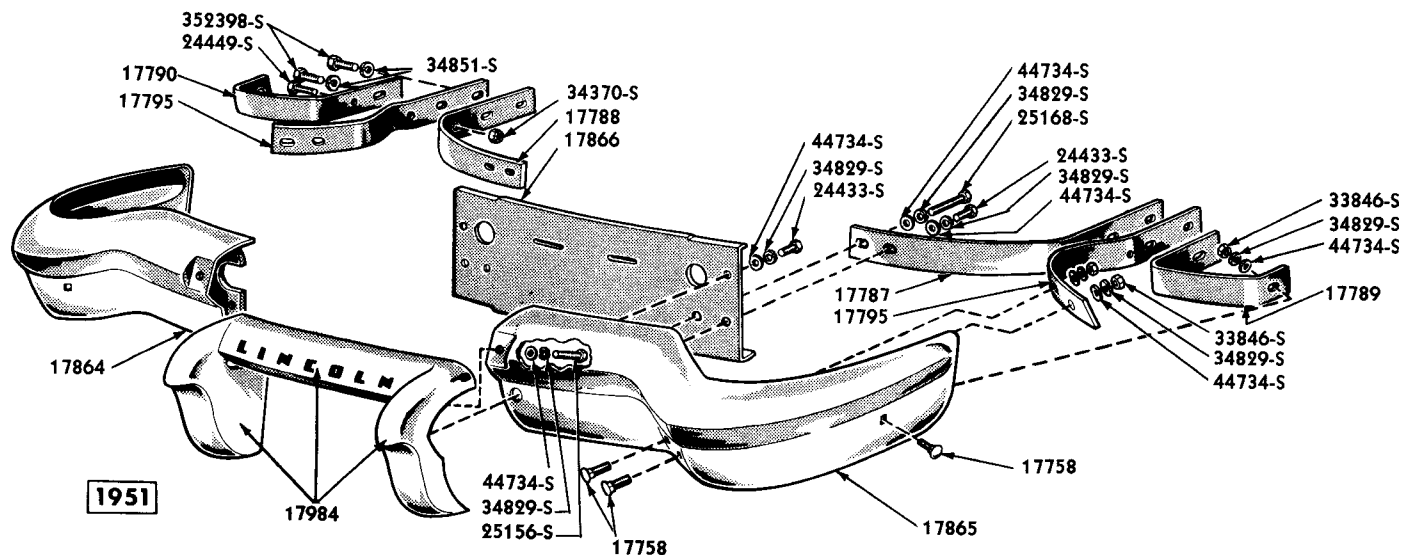

PL-523

## LINCOLN REAR BUMPER AND RELATED PARTS

Basic numbers only shown on illustration. Order by Part Numbers shown in list of parts.

### Shock Absorbers

PART NUMBER	QUANTITY	PART NAME	NO. REQ'D	MODEL	YEAR
	NS	8L-19541-A Fluid (shock absorber)-pt.-replaced by 8L-19541-C	1	9L,9H,OL,OH,1L,1H	49-51
		8L-19541-B Fluid (shock absorber)-gal.	1	9L,9H,OL,OH,1L,1H	49-51
		8L-19541-C Fluid (shock absorber)-consists of (12) 1 pint containers	as req'd	9L,9H,OL,OH,1L,1H	49-51
8M 18031		Seat (front shock absorber insulator)-1-3/16" O.D. x 5/8" I.D.-Steel	4	9L,9H,OL,OH,1L,1H	49-51
8M 18039		Washer (front shock absorber insulator)-inner-1-1/4" O.D. x 1/2" I.D.-Steel-heavy duty shock absorber	4	9L,9H,OL,OH,1L,1H	49-51
51A 18040		Washer (shock absorber)-outer-1-1/4" O.D. x 17/32" I.D.-Steel	4	9L,9H,OL,OH,1L,1H	49-51
8M 18041		Washer (front shock absorber insulator)-1-1/4" O.D. x 13/32" I.D.-Steel	8	9L,9H,OL,OH,1L,1H	49-51
8L 18045-C		Shock absorber assy (front)-Monroe-heavy duty type	2	9L,9H,OL,OH,1L,1H	49-51
		24429-S7 Bolt (hex-hi)-3/8"-24 x 1-1/4"-heavy duty shock absorber	2	9L,9H,OL,OH,1L,1H	49-51
		45218-S8 Locknut (hex)-3/8"-24	4	9L,9H,OL,OH,1L,1H	49-51
		33800-S8 Nut (hex)-3/8"-24-absorber to mounting plate	2	9L,9H,OL,OH,1L,1H	49-51
		33800-S8 Nut (hex)-3/8"-24-absorber to frame bracket	2	9L,9H,OL,OH,1L,1H	49-51



# Lincoln and Lincoln Cosmopolitan

## CHASSIS PARTS CATALOGUE

PART NUMBER	PART NAME	NO. REQ'D	MODEL	YEAR 19__
HAK 18045-A	Kit (front shock absorber bushing)-consists of the following (2) 8M-18031 Seat (4) 8M-18041 Washer (4) 8M-18198 Insulator (2) 45218-S8 Locknut	1	9L,9H,OL,OH,1L,1H	49-51
8M 18072-A	Plate (front shock absorber mounting)	2	9L,9H,OL,OH	49-50
8M 18072-B	Plate (front shock absorber mounting)-heavy duty type	2	9L,9H,OL,OH,1L,1H	49-51
	34806-S7 Lockwasher-5/16"	4	9L,9H,OL,OH,1L,1H	49-51
	33798-S8 Nut (hex)-5/16"-24	4	9L,9H,OL,OH,1L,1H	49-51
	8M-18198 Insulator (front shock absorber)-Rubber	8	9L,9H,OL,OH,1L,1H	49-51
8L 18080	Shock absorber assy (rear)-Monroe-heavy duty type	2	9L,9H,OL,OH,1L,1H	49-51
8M 18080-A	Shock absorber assy (rear)-Gabriel	2	9L,9H,OL,OH	49-50
	24429-S7 Bolt (hex-hd)-3/8"-24 x 1-1/4"	2	9L,9H,OL,OH,1L,1H	49-51
	34399-S7 Locknut-1/2"-20-shock to rear spring clip plate	2	9L,9H,OL,OH,1L,1H	49-51
	34449-S7-8 Nut (hex huglock)-1/2"-20-absorber to stud	4	9L,9H,OL,OH,1L,1H	49-51
HAK 18080-A	Kit (rear shock absorber bushing)-consists of the following (2) 8M-18039 Washer (2) 51A-18040 Washer (4) 51A-18197 Bushing	1	9L,9H,OL,OH,1L,1H	49-51

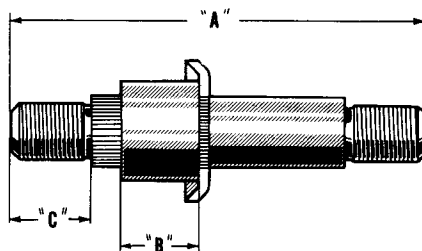

PL-297

### REAR SHOCK ABSORBER STUD CHART

PART NUMBER	A	B	C	LOCATION	NO. REQ'D	USED WITH SHOCK ABSORBER	MODEL	YEAR 19__
8M-18152	3-29/64"	47/64"	63/64"	Upper	2	8L-18080	9L,9H,OL,OH,1L,1H	49-51
8M-18152	3-29/64"	47/64"	63/64"	Lower	2	8L-18080	9L,9H,OL,OH,1L,1H	49-51
8M-18165-A	3-33/64"	31/64"	23/32"	Upper	2	8M-18080-A	9L,9H,OL,OH	49-50
8M-18165-A	3-33/64"	31/64"	23/32"	Lower	2	8M-18080-A	9L,9H,OL,OH	49-50
8M-18165-B	3-3/4"	35/64"	23/32"	Lower	2	8L-18080	9L,9H,OL,OH	49-50

PART NUMBER	PART NAME	NO. REQ'D	MODEL	YEAR 19__
51A-18197	Bushing (rear shock absorber insulator)-Rubber	8	9L,9H,OL,OH,1L,1H	49-51

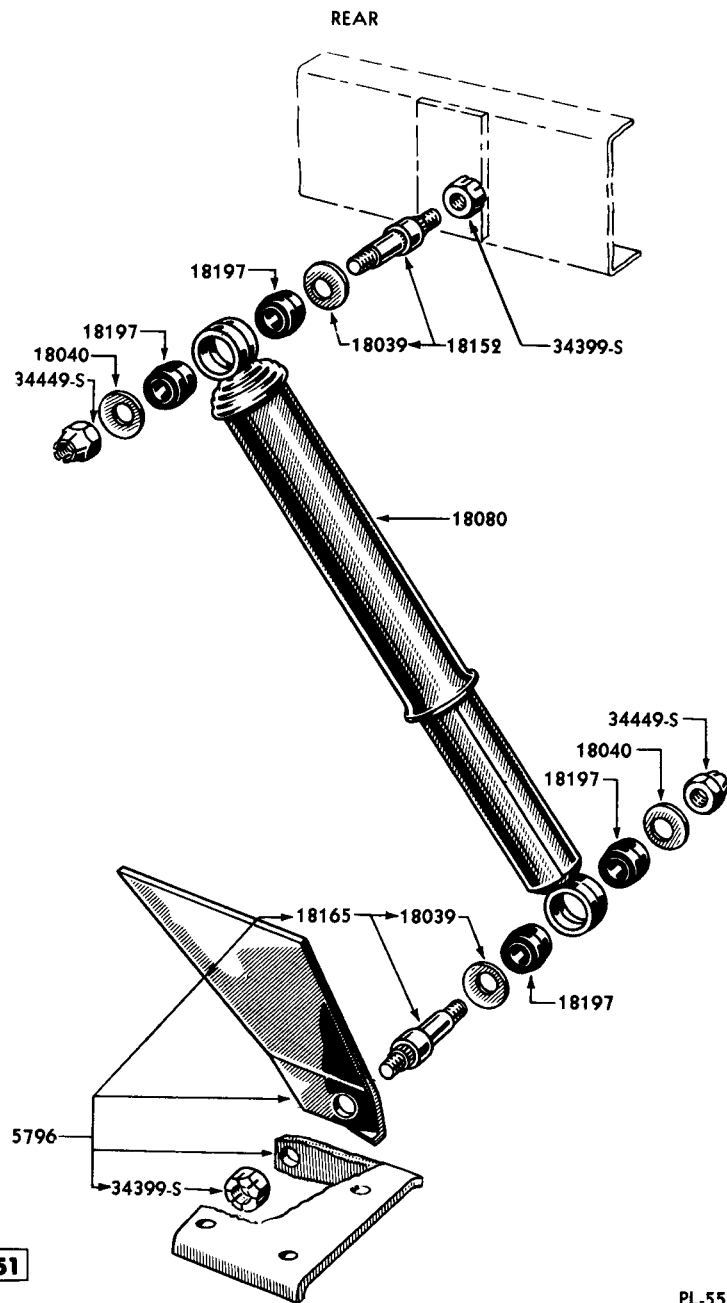
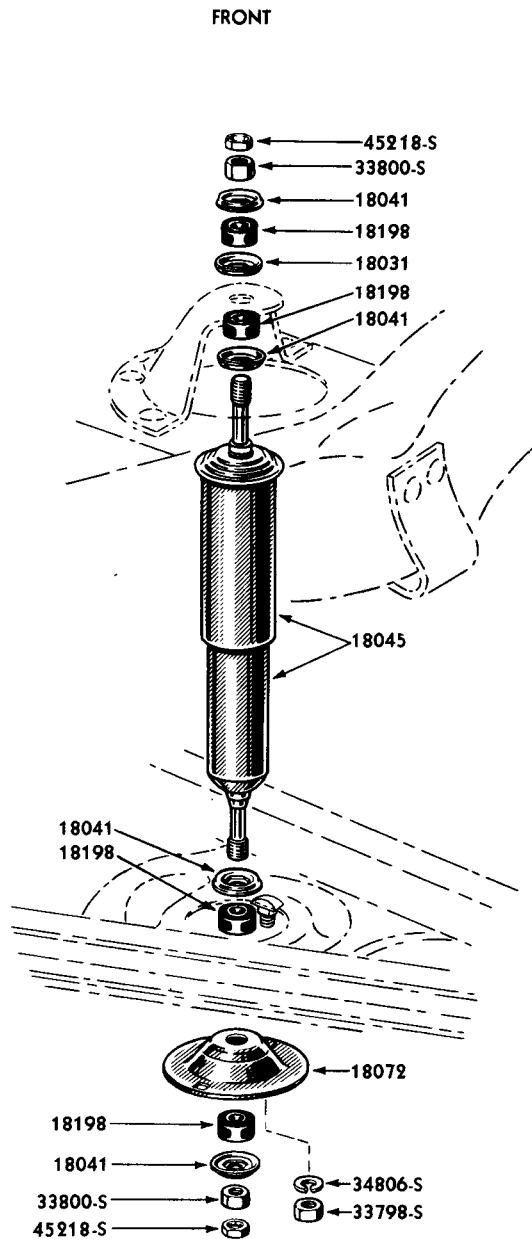

1949-51

PL-554

## SHOCK ABSORBERS AND RELATED PARTS

Basic numbers only shown on illustration. Order by Part Numbers shown in list of parts.

# Lincoln and Lincoln Cosmopolitan

## CHASSIS PARTS CATALOGUE

PART NUMBER	QUANTITY	PART NAME	NO. REQ'D	MODEL	YEAR 19__
<b>Numerical List of 18,000 Miscellaneous Accessories</b>					
OL 18148		Spotlight assy-less brackets	1	9L,9H,OL,OH,1L,1H	49-51
8M 18152		Stud assy (rear shock absorber)-upper-heavy duty type	4	9L,9H,OL,OH,1L,1H	49-51
8H 18154		Kit (spotlight bracket installation)-RH	1	9L76,9H,OH	49-50
8L 18154		Kit (spotlight bracket installation)-RH	1	9L72-74,OL,1L,1H72-74	49-51
8M 18154		Kit (spotlight bracket installation)-RH	1	1H76	51
8H 18155		Kit (spotlight bracket installation)-LH	1	9L76,9H,OH	49-50
8L 18155		Kit (spotlight bracket installation)-LH	1	9L72-74,OL,1L,1H72-74	49-51
8M 18155		Kit (spotlight bracket installation)-LH	1	1H76	51
OH 18159		Kit (hand brake signal lamp installation)	1	9L,9H,OL,OH,1L,1H	49-51
8M 18165-A		Stud and washer assy (rear shock absorber)	4	9L,9H,OL,OH,1L,1H	49-51
8M 18165-B		Stud and washer assy (rear shock absorber)-heavy duty type	2	9L,9H,OL,OH,1L,1H	49-51
8H 18168-C		Kit (gas filler lid lock installation)	1	9H,OH	49-50
1L 18168		Kit (gas filler lid lock installation)	1	1L,1H	51
51A 18197		Bushing (shock insulator)-Rubber	8	9L,9H,OL,OH,1L,1H	49-51
8M 18198		Insulator (front shock absorber)	8	9L,9H,OL,OH,1L,1H	49-51
1H 18207-A		Kit (roadlamp installation)	1	1L,1H	51
FAA 18208-A		Kit (visor vanity mirror installation)	1	9L,9H,OL,OH,1L,1H	49-51
LBK 18243-A		Kit (curb buffer moulding installation)	1	1L	51
OL 18259		Deflector assy (exhaust)	1	9L,9H,OL,OH,1L,1H	49-51
HAK 18259-A		Kit (exhaust deflector)	as reqd	9L,9H,OL,OH,1L,1H	49-51
1H 18274-A		Kit (back up lamp installation)	1	1L,1H	51
HAK 18295-A		Kit (reading and vanity light installation)	1	9L,9H,OL,OH,1L,1H	49-51
1M 18296		Guard (fuel tank filler neck opening)	1	1L	51
8H 18306		Key (glove box and rear compartment door)	2	9L,9H,OL,OH,1L,1H	49-51
HAK 18333-A		Kit (rear door safety lock installation)-includes (12) 1H-18333 Kits	1	9L74,9H73-74,OL74,OH74,1L74,1H74	49-51
1H 18333	NS	Kit (rear door safety lock)-serviced in HAK-18333-A Kit	1	9L74,9H73-74,OL74,OH74,1L74,1H74	49-51
8H 18344		Kit (spark plug insulator installation)	1	9L,9H,OL,OH,1L,1H	49-51
8L 18349		Extension assy (spare tire valve)	1	9L,OL,1L,1H	49-51
1EL 18368-A		Kit (thermostat)-177° to 182° opening temperature	1	9L,9H,OL,OH,1L,1H	49-51
8H 18375-A		Kit (engine compartment lamp installation)	1	9L,9H,OL,OH,1L,1H	49-51
HAK 18387-A		Kit (rear window wiper installation)	1	OL,OH72-74,1H72-74	50-51
1L 18387-A		Kit (rear window wiper installation)	1	1L	51

# Lincoln and Lincoln Cosmopolitan

## CHASSIS PARTS CATALOGUE

PART NUMBER	QUANTITY	PART NAME	NO. REQ'D	MODEL	YEAR
					19__
<b>Numerical List of 18,000 Miscellaneous Accessories—Continued</b>					
1L 18400		Kit (rear view mirror installation)-inside-non glare	1	1L	51
8H 18402		Mirror assy (outside rear view)-RH	1	9H	49
1H 18402-B		Kit (rear view mirror installation)-outside	1	1L,1H	51
8H 18403		Mirror assy (outside rear view)-LH	1	9H	49
8H 18456-A		Blower assy (heater)	1	9H	49
8H 18456-B		Blower assy (heater)-with two wires from motor	1	OH	50
OH 18456-A		Blower assy (heater)-with three wires from motor	1	OH,1H	50-51
8L 18456-A		Blower and adapter assy (heater)	1	9L	49
OM 18456-B		Blower assy (heater)-complete	1	OL,1L	50-51
8M 18471-A		Plenum chamber assy (heater)	1	9L,9H	49
OH 18471-A		Plenum chamber assy (heater)	1	OH	50
OH 18471-B		Plenum chamber assy (heater)	1	OH,1H	50-51
OM 18471-A		Plenum chamber assy (heater)	1	OL,1L	50-51
8H 18472-A	NS	Hose (heater inlet)-17-1/2" long-make from 8M-18472-D	1	9H	49
8H 18472-B	NS	Hose (heater return)-37" long-make from 8M-18472-D	1	9H	49
8H 18472-C	NS	Hose (heater temperature control)-19-1/2" long-make from 8M-18472-D	1	9H	49
8L 18472-A	NS	Hose (heater inlet)-21" long-make from 8M-18472-D	1	9L	49
8M 18472-D		Hose (heater)-9/16" I.D. x 1" O.D. x 100' long	as reqd	9L,9H,OL,OH	49-50
1A 18472-A	NS	Hose (heater temperature control)-18" long-make from 1M-18472-C	1	9L,OL,1L	49-51
1A 18472-B	NS	Hose (heater outlet)-39" long-make from 1M-18472-C	1	OH,1H	50-51
1M 18472-B	NS	Hose (heater return)-30" long-make from 1M-18472-C	1	9L,OL,1L	49-51
1M 18472-C		Hose (heater)-5/8" I.D. x 15/16" O.D. x 100' long	as reqd	9L,9H,OL,OH,1L,1H	49-51
OL 18475-A		Plate (heater control name)	1	OL,OH	50
OL 18475-B		Plate (control name)	1	OL,OH,1L,1H	50-51
8H 18477-A		Core assy (heater)	1	9H	49
8M 18477-A		Core assy (heater)	1	9L	49
OH 18477		Core assy (heater)	1	OH,1H	50-51
OM 18477		Core assy (heater)	1	OL,1L	50-51
8H 18478-A		Heater assy (fresh air hot water)-less blower	1	9H	49
8M 18478-A		Heater assy (fresh air hot water)-less blower	1	9L	49
OH 18478		Heater assy (fresh air hot water)-less blower	1	OH,1H	50-51
OM 18478-B		Heater assy (fresh air hot water)-less blower	1	OL,1L	50-51
5EH 18480-A		Frame (license plate)-square corners-except California and Wisconsin	1	9L,9H,OL,OH,1L,1H	49-51
5EH 18480-B		Frame (license plate)-round corners-for California and Wisconsin	1	9L,9H,OL,OH,1L,1H	49-51
7RA 18481		Bracket (heater hose support)	1	OH	50
8C 18481-A		Bracket (heater hose support)	1	OL,OH	50
8L 18481		Bracket (heater hose support)	1	9L	49
8H 18481		Bracket (heater hose support)	1	9H	49
1L 18481		Bracket (heater hose support)	1	1L,1H	51
8H 18482		Seal (heater blower)	1	9H	49

# Lincoln and Lincoln Cosmopolitan

## CHASSIS PARTS CATALOGUE

PART NUMBER	C O D E	PART NAME	NO. REQ'D	MODEL	YEAR 19
<b>Numerical List of 18,000 Miscellaneous Accessories—Continued</b>					
8H 18487		Flange (heater blower duct)	1	9H	49
8H 18490		Nozzle assy (heater defroster)	2	9H	49
*OM 18490		Nozzle (heater defroster)-Zinc Die Cast-alternate with 1A-18490-A	2	OL,OH,LL,1H	50-51
*1A 18490-A		Nozzle assy (heater defroster)-Painted Steel-alternate with OM-18490	2	OL,OH,LL,1H	50-51
11A 18491-B		Nozzle assy (heater defroster)	2	9L	49
1L 18498		Moulding (heater control name plate)	1	1L,1H	51
8M 18502-B		Valve (automatic temperature water regulator)	1	9L,9H	49
OH 18502		Valve assy (heater automatic temperature regulator)	1	OH,1H	50-51
OM 18502		Valve assy (heater automatic temperature regulator)	1	OL	50
1M 18502-B		Valve assy (heater automatic temperature regulator)	1	1L	51
8A 18504		Wheel assy (heater blower)	1	9L,9H,OL,LL	49-51
8C 18504-A		Wheel assy (heater blower)	1	OH,1H	50-51
OM 18506		Housing and core assy (heater)	1	OL,1L	50-51
8L 18511		Bracket and control handle assy (automatic temperature regulator)	1	9L,9H	49
OL 18513		Knob assy (heater blower switch & antenna control)	2	OL,OH	50
1L 18513		Knob assy (heater blower switch and radio antenna control)	2	1L,1H	51
8H 18518-A		Control assy (fresh air)-straight end-19" long	1	9H	49
8H 18518-B		Control assy (fresh air)-pigtail end-20" long	1	9H	49
8L 18518-A		Control assy (fresh air)-straight end-24-1/2" long	1	9L	49
8L 18518-B		Control assy (fresh air)-pigtail end-24-1/4" long	1	9L	49
OH 18518-E		Control assy (heater temperature)	1	OH,1H	50-51
OL 18518-E		Control assy (heater temperature)	1	OL	50
1M 18518-A		Control assy (heater temperature)-46" long	1	1L	51
OL 18519		Knob assy (heater regulator control)	2	OL,OH,LL,1H	50-51
8H 18526		Plug (defroster opening end)-Rubber	4	9H	49
8L 18527		Motor assy (heater blower)	1	9L,9H	49
OH 18527-B		Motor assy (heater blower)	1	OH,1H	50-51
OM 18527-B		Motor assy (heater blower)	1	OL,LL	50-51
8L 18529		Knob (automatic temperature regulator control)	1	9L,9H	49
8H 18543		Bracket (heater blower)	1	9H	49
8H 18548		Control assy (heater defroster)-22-1/8" long	1	9H	49
8L 18546		Control assy (heater defroster)-17-5/8" long	1	9L	49
OH 18548-B		Control assy (heater defroster)-31-1/2" long	1	OH,1H	50-51
OL 18548-B		Control assy (heater defroster)-26-1/4" long	1	OL,LL	50-51
OL 18549		Control assy (heater temperature regulator)	1	OL,OH	50
1A 18551-A		Hose (water regulator to heater)-formed	1	9L	49
OM 18551		Hose (heater temperature regulator to heater core)-formed	1	OL,LL	50-51
1H 18551-A	NS	Hose (heater temperature valve to heater core)-6" long-make from 1M-18472-C	1	OH,1H	50-51
1M 18551-A	NS	Hose (heater temperature valve to heater core)-formed-use OM-18551 for service	1	1L	51

\* Alternate material due to Material Emergency

# Lincoln and Lincoln Cosmopolitan

## CHASSIS PARTS CATALOGUE

PART NUMBER	PART NAME	NO. REQ'D	MODEL	YEAR
<b>Numerical List of 18,000 Miscellaneous Accessories—Continued</b>				
8H 18556-A	Hose (heater defroster)-passenger side	1	9H	49
8H 18556-B	Hose (heater defroster)-driver's side	1	9H	49
8M 18556-A	Hose (heater defroster)-passenger side	2	9L	49
8M 18556-B	Hose (heater defroster)-driver's side	2	9L	49
OH 18556-A	Hose (heater defroster)-8-1/2" long	2	OH, 1H	50-51
OL 18556-A	Hose (heater defroster)-11-1/2" long-passenger side	1	OL, 1L	50-51
OL 18556-B	Hose (heater defroster)-31-1/2" long-driver's side	1	OL, 1L	50-51
OL 18561-A	Control assy (fresh air regulator)-with one piece lever	1	OL, OH	50
OM 18561-B	Control assy (fresh air regulator)-with riveted lever	1	OL, OH, 1L, 1H	50-51
8L 18565	Mounting and motor assy (heater blower)	1	9L, 9H	49
OH 18565-A	Mounting and motor assy (heater blower)	1	OH, 1H	50-51
A 18570	Bulb (utility lamp)-32 C.P.-S.C.	1	9L, 9H, OL, OH, 1L, 1H	49-51
8H 18570-A	Gasket (heater)-outer	1	9H	49
8H 18570-B	Gasket (fresh air heater)-inner	1	9H	49
8M 18570-A	Gasket (fresh air duct flange to dash)	2	9L, 9H, OL, 1H	49-51
8M 18570-B	Gasket (blower motor housing to dash)	1	9L	49
8M 18570-C	Gasket (heater core housing to dash)	1	9L	49
OM 18570-A	Gasket (heater core housing)-Rubber-3-7/8" x 6-15/16"	1	OL, 1L	50-51
OM 18570-B	Gasket (heater blower housing to valve assy)-Rubber-5-1/4" x 4"	1	OL, 1L	50-51
7RA 18572-A	Clamp (heater hose)	6or8	9L, 9H	49
OA 18572-A	Clamp (heater hose)-stamped "OA-A1 or 2"	4or6	OL, OH	50
1C 18572-A	Clamp (heater hose)-stamped "1C-A1 or 2"	6	1L, 1H	51
8A 18578-A	Switch assy (heater control)	1	9L, 9H	49
OL 18578-B	Switch assy (heater control)	1	OL, OH	50
1H 18578-A	Switch assy (heater control)	1	1L, 1H	51
8L 18580	Washer (blower motor to housing)-extended	2	9L, 9H	49
8M 18583	Gasket (motor mounting to dash)	1	9L, 9H	49
8H 18583	Gasket (heater blower motor mounting)-3-3/8" O.D. x 1-1/2" I.D.-Felt	1	OL, OH, 1L, 1H	50-51
8H 18584-A	Duct (heater)-flexible-10" long	1	9H	49
OH 18584	Duct (heater blower to dash)-4-5/64" O.D. x 3-31/32" I.D. x 3-1/2" wide-Rubber	1	OH, 1H	50-51
OL 18590	Clip (fresh air regulator control)	1	OL, OH, 1L, 1H	50-51
OM 18590	Clip (fresh air control cable)	1	OL, 1L	50-51
OH 18591	Resistor (heater switch)	1	OL, OH	50
8M 18595	Gasket (heater temperature regulator)	1	9L, 9H	49
OM 18595	Gasket (heater temperature regulator)	1	OL, OH, 1L, 1H	50-51
8M 18596	Gasket (heater core tubes)	1	9L, 9H	49
OL 18598	Bezel (heater switch and antenna control)	2	OL, OH, 1L, 1H	50-51
1GA 18599	Elbow (heater connection)-90° angle	1	9H	49
8A 18599	Elbow (heater connection)-45° angle	1or2	9L, 9H, OL, OH, 1L, 1H	49-51
OH 18599	Elbow (heater hose connection)-90° angle	1	OH, 1H	50-51
OH 18627-B	End assy (heater plenum chamber)-RH	1	OH, 1H	50-51
OH 18630-C	End assy (heater plenum chamber)-LH	1	OH, 1H except 76	50-51
OH 18630-D	NS End assy (heater plenum chamber)-LH-make from OH-18630-C	1	OH76, 1H76	50-51

# Lincoln and Lincoln Cosmopolitan

## CHASSIS PARTS CATALOGUE

PART NUMBER	PART NAME	NO. REQ'D	MODEL	YEAR 19__
<b>Numerical List of 18,000 Miscellaneous Accessories—Continued</b>				
OH 18645	Duct assy (heater to plenum chamber)	1	OH, 1H	50-51
OM 18646	Control assy (air regulator)-LH	1	OL, OH, 1L, 1H	50-51
OH 18648	Hose (heater inlet)-formed	1	OH	50
1H 18648-A	Hose (heater inlet)-formed	1	1H	51
OM 18654	Screw and lockwasher assy (heater to dash)-1/4"-28 x 1/2"	2	OL, 1L	50-51
1H 18805-A	Radio assy (8 tube)-less antenna	1	1L, 1H	51
8L 18812	Lead-in assy (radio antenna)-34-1/2" long	1	9L	49
8H 18812	Lead-in assy (radio antenna)-50" long	1	9H	49
OH 18812	Lead-in assy (radio antenna)-52-1/2" long	1	OH, 1H	50-51
OL 18812	Lead-in assy (radio antenna)-41-1/2" long	1	OL, 1L	50-51
8L 18813	Antenna assy (radio)-vacuum	1	9L	49
OH 18813-C	Antenna assy (radio)-vacuum	1	OH	50
OL 18813	Antenna assy (radio)-vacuum	1	OL	50
1H 18813	Antenna assy (radio)-vacuum	1	1H	51
1L 18813	Antenna assy (radio)-vacuum	1	1L	51
8H 18817	Knob (radio receiver)-volume control	1	9L, 9H	49
OL 18817	Knob assy (radio volume control and roadlamp switch)	3	OL, OH	50
1H 18817	Knob assy (radio volume control and roadlamp control switch)-gold with black base-fin type	3	1L, 1H	51
8H 18818	Disc (radio knob trim)-tone control	1	9L, 9H	49
8H 18824	Knob assy (radio tuning control)	1	9L, 9H	49
OL 18830	Disc (radio tone and rear seat speaker volume control)	2	OL, OH, 1L, 1H	50-51
8H 18842	Bezel (radio control)	1	9H	49
8L 18842	Bezel (radio control)	1	9L	49
5EH 18848	Tee (vacuum antenna)	1	9L, 9H, OL, OH, 1L, 1H	49-51
8M 18850	Rod and cylinder assy (radio antenna)	1	9L, 9H	49
OH 18850	Rod and cylinder assy (radio antenna)	1	OH, 1H	50-51
OL 18850	Rod and cylinder assy (radio antenna)	1	OL, 1L	50-51
OL 18856	Button (radio knob opening plug)-used in cars w/o radio.	2	OL, OH, 1L, 1H	50-51
8M 18863	Valve assy (vacuum antenna)-vacuum	1	9L, 9H	49
OL 18863	Valve assy (radio antenna)-vacuum	1	OL, OH	50
1H 18863	Valve assy (radio antenna)-vacuum	1	1L, 1H	51
5EH 18865-B	Nut (vacuum antenna dome)	1	9L, 9H, OL, OH, 1L, 1H	49-51
OH 18875	Speaker assy (rear seat)-Flush type	1	OL, OH, 1L, 1H, except 76	50-51
8H 18888	Support (radio receiver rear)-4-7/8" long	1	9H	49
8L 18888-A	Support (radio receiver rear)-6-7/16" long	1	9L	49
8L 18888-B	Support (radio receiver rear)-5-1/4" long	1	9L	49
OL 18888	Support (radio receiver rear)-RH	1	OL, OH, 1L, 1H	50-51
OL 18890	Support (radio receiver rear)-LH	1	OL, OH, 1L, 1H	50-51

# Lincoln and Lincoln Cosmopolitan

## CHASSIS PARTS CATALOGUE

PART NUMBER	CLASS	PART NAME	NO. REQ'D	MODEL	YEAR 19__
<b>Numerical List of 18,000 Miscellaneous Accessories—Continued</b>					
8M 18897		Insulator (vacuum antenna)	1	9L,OL,1L	49-51
8H 18897		Insulator (vacuum antenna)	1	9H	49
OH 18897		Insulator (vacuum antenna)	1	OH,1H	50-51
8M 18898		Gasket (vacuum antenna)	1	9L,OL,1L	49-51
8H 18898		Gasket (vacuum antenna)	1	9H	49
OH 18898		Gasket (vacuum antenna)	1	OH,1H	50-51
8L 18911		Knob (vacuum antenna control valve)	1	9L,9H	49
8M 18912		Grommet (antenna lead-in seal)	1	9L,9H,OL,OH,1L,1H	49-51
OL 18926		Bezel (radio antenna control)	1	OL,OH	50
8H 18931-A	NS	Hose (radio antenna)-70" long-make from 8M-18931-D	1	9H	49
8H 18931-B	NS	Hose (radio antenna)-57" long-make from 8M-18931-D	1	9H	49
8H 18931-C	NS	Hose (radio antenna)-25" long-make from 8M-18931-D	1	9H	49
8L 18931-A	NS	Hose (radio antenna)-20" long-make from 8M-18931-D	1	9L	49
8L 18931-B	NS	Hose (radio antenna)-45-1/2" long-make from 8M-18931-D	1	9L	49
8L 18931-C	NS	Hose (radio antenna)-61-1/2" long-make from 8M-18931-D	1	9L	49
8M 18931-D		Hose (radio antenna)-25' roll	1	9L,9H,OL,OH,1L,1H	49-51
OH 18931-A	NS	Hose (radio antenna)-38" long-make from 8M-18931-D	1	OH,1H	50-51
OH 18931-B	NS	Hose (radio antenna)-71-1/2" long-make from 8M-18931-D	1	OH,1H	50-51
OH 18931-C	NS	Hose (radio antenna)-90" long-make from 8M-18931-D	1	OH,1H	50-51
OL 18931-A	NS	Hose (radio antenna)-17-1/2" long-make from 8M-18931-D	1	OL,1L	50-51
OL 18931-B	NS	Hose (radio antenna)-58" long-make from 8M-18931-B	1	OL,1L	50-51
8M 18939		Bracket (radio antenna)	1	9L,9H,OL,1L	49-51
OH 18939-C		Bracket (radio antenna)	1	OH,1H	50-51
OH 18947		Spacer (radio antenna grounding)	1	OH,1H	50-51
OL 18947		Spacer (radio antenna grounding)	1	OL,1L	50-51
8M 18951		Extension assy (radio receiver support)	1	9L	49
8L 18954		Clamp (radio antenna hose)-strap-3-5/32" long	1	9L,9H	49
8L 18954		Clamp (roadlamp wiring)-strap-3-5/32" long	5	OL,OH	50
8L 18954		Clamp (W/S washer hose)-strap-3-5/32" long	3-5	9L,9H,OL,OH,1L,1H	49-51
8L 18954		Clamp (engine compt. lamp wire)-strap-3-5/32" long	5	9L,9H,OL,OH,1L,1H	49-51
8M 18954	NS	Clamp (back up lamp wiring)-use 8L-18954 for service	2	1L,1H	51
8M 18954	NS	Clamp (radio antenna hose)-use 8L-18954 for service	2	OL,OH,1L,1H	50-51
OL 18965		Bracket assy (radio antenna vacuum)	1	OL,1L	50-51
8M 18966		Washer assy (vacuum antenna)	1	9L,9H,OL,OH,1L,1H	49-51



# Lincoln and Lincoln Cosmopolitan

## CHASSIS PARTS CATALOGUE

PART NUMBER	CLASS	PART NAME	NO. REQ'D	MODEL	YEAR 19
<b>Numerical List of 19,000 Miscellaneous Accessories</b>					
BD 19512-A		Mitt (car washing)-Chenille		9L,9H,0L,0H,1L,1H	49-51
1M 19514-A		Coating (Chrome)-8 oz. can		1L,1H	51
8L 19515-B		Undercoating (body)-53 gal. drum		9L,9H,0L,0H,1L,1H	49-51
HACA 19517-A	NS	Cloth (dust)-wax treated		9L,9H,0L,0H,1L,1H	49-51
HACA 19517-B		Cloth (dust)-wax treated-package of (12) HACA-19517-A cloths		9L,9H,0L,0H,1L,1H	49-51
8L 19520-A	NS	Cleaner (body)-liquid-pt.-replaced by 8L-19520-D		9L,9H,0L,0H,1L,1H	49-51
8L 19520-D		Cleaner (body)-liquid-case of (12) pt. cans		9L,9H,0L,0H,1L,1H	49-51
8L 19521-A	NS	Cleaner (spot remover)-pt.-replaced by 8L-19521-C		9L,9H,0L,0H,1L,1H	49-51
8L 19521-B		Cleaner (spot remover)-gal.		9L,9H,0L,0H,1L,1H	49-51
8L 19521-C		Cleaner (spot remover)-case of (12) pt. cans		9L,9H,0L,0H,1L,1H	49-51
8L 19522-A	NS	Cleaner (chrome)-pt.-replaced by 8L-19522-B		9L,9H,0L,0H,1L,1H	49-51
8L 19522-B		Cleaner (chrome)-case of (12) pt. cans		9L,9H,0L,0H,1L,1H	49-51
8H 19523-A	NS	Cleaner (white side wall tire)-13 oz. can-replaced by 8E-19523-B		9L,9H,0L,0H,1L,1H	49-51
8H 19523-B		Cleaner (white side wall tire)-case of (12) 13 oz. cans		9L,9H,0L,0H,1L,1H	49-51
8L 19526-A	NS	Cleaner (upholstery foam)-pt.-replaced by 8L-19526-C		9L,9H,0L,0H,1L,1H	49-51
8L 19526-C		Cleaner (upholstery foam)-case of (12) pt. cans		9L,9H,0L,0H,1L,1H	49-51
8L 19528-A	NS	Compound (body porcelainize)-liquid-8 oz. bottle-replaced by 8L-19528-C		9L,9H,0L,0H,1L,1H	49-51
8L 19528-C		Compound (body porcelainize)-liquid-case of (24) 8 oz. bottles		9L,9H,0L,0H,1L,1H	49-51
8L 19529-A	NS	Polish (body porcelainize)-cream-8 oz. bottle-replaced by 8L-19529-C		9L,9H,0L,0H,1L,1H	49-51
8L 19529-C		Polish (body porcelainize)-cream-case of (24) 8 oz. bottles		9L,9H,0L,0H,1L,1H	49-51
8L 19530-A	NS	Polish (body)-pt.-replaced by 8L-19530-C		9L,9H,0L,0H,1L,1H	49-51
8L 19530-C		Polish (body)-case of (12) pt. cans		9L,9H,0L,0H,1L,1H	49-51
BD 19530-A		Polish (body)-Blue Coral-16.18 imperial oz.		9L,9H,0L,0H,1L,1H	49-51
BD 19530-B		Polish (body)-Lectron-16 oz.		9L,9H,0L,0H,1L,1H	49-51
8L 19534-A	NS	Wax (body polishing)-8 oz. can-replaced by 8L-19534-B		9L,9H,0L,0H,1L,1H	49-51
8L 19534-B		Wax (body polishing)-case of (12) 8 oz. cans		9L,9H,0L,0H,1L,1H	49-51
BD 19534-A		Wax (body)-Blue Coral-80 grams		9L,9H,0L,0H,1L,1H	49-51
BD 19534-B		Wax (body)-Blue Coral-227 grams		9L,9H,0L,0H,1L,1H	49-51
8L 19541-A	NS	Fluid (shock absorber)-pt.-replaced by 8L-19541-C		9L,9H,0L,0H,1L,1H	49-51
8L 19541-B		Fluid (shock absorber)-gal.		9L,9H,0L,0H,1L,1H	49-51
8L 19541-C		Fluid (shock absorber)-case-consists of (12) pt. cans		9L,9H,0L,0H,1L,1H	49-51

# Lincoln and Lincoln Cosmopolitan

## CHASSIS PARTS CATALOGUE

PART NUMBER	MFG	PART NAME	NO. REQ'D	MODEL	YEAR 19
<b>Numerical List of 19,000 Miscellaneous Accessories—Continued</b>					
HACA-19542-A	NS	Fluid (brake)-heavy duty-pt.-replaced by HACA-19542-C		9L,9H,OL,OH,1L,1H	49-51
HACA 19542-B	NS	Fluid (brake)-heavy duty-gallon-replaced by HACA-19542-D		9L,9H,OL,OH,1L,1H	49-51
HACA-19542-C		Fluid (brake)-heavy duty-case of (12) pt. cans		9L,9H,OL,OH,1L,1H	49-51
HACA 19542-D		Fluid (brake)-heavy duty-case of (4) gal. cans		9L,9H,OL,OH,1L,1H	49-51
HACA 19542-E		Fluid (brake)-heavy duty-5 gal. can		9L,9H,OL,OH,1L,1H	49-51
8M 19544-A		Anti-freeze (type N)-gal.		9L,9H,OL,OH,1L,1H	49-51
8M 19544-B		Anti-freeze (type N)-54 gal.		9L,9H,OL,OH,1L,1H	49-51
8H 19544		Anti-freeze (permanent)-gal.		9L,9H,OL,OH,1L,1H	49-51
8H 19544-B		Anti-freeze (permanent)-case of (24) qt. cans		9L,9H,OL,OH,1L,1H	49-51
HACA 19544-A	NS	Anti-freeze (permanent)-qt.-replaced by 8H-19544-B		9L,9H,OL,OH,1L,1H	49-51
8L 19545-A	NS	Fluid (window regulator)-pt.-replaced by 8L-19545-B		9L,9H,OL,OH,1L,1H	49-51
8L 19545-B		Fluid (window regulator)-case of (12) pt. cans		9L,9H,OL,OH,1L,1H	49-51
8H 19546-A	NS	Rust Inhibitor-pt.-replaced by 8H-19546-B		9L,9H,OL,OH,1L,1H	49-51
8H 19546-B		Rust Inhibitor-case of (12) pt. cans		9L,9H,OL,OH,1L,1H	49-51
8L 19550-A	NS	Solution (W/S washer)-6 oz.-replaced by 8L-19550-B		9L,9H,OL,OH,1L,1H	49-51
8L 19550-B		Solution (W/S washer)-case of (12) 6 oz. cans		9L,9H,OL,OH,1L,1H	49-51
8L 19552-A	NS	Cement (rubber)-5 oz.-replaced by 8L-19552-B		9L,9H,OL,OH,1L,1H	49-51
8L 19552-B		Cement (rubber)-case of (12) 5 oz. tubes		9L,9H,OL,OH,1L,1H	49-51
8M 19554-A	NS	Sealer (compound)-16 oz.-replaced by 8M-19554-B		9L,9H,OL,OH,1L,1H	49-51
8M 19554-B		Sealer (compound)-case of (12) 16 oz. cans		9L,9H,OL,OH,1L,1H	49-51
8L 19558-A	NS	Radiator Stop Leak-10 oz.-replaced by 8L-19558-B		9L,9H,OL,OH,1L,1H	49-51
8L 19558-B		Radiator Stop Leak-case of (12) 10 oz. cans		9L,9H,OL,OH,1L,1H	49-51
8M 19560-A		Kit-caulking strips-case of (8) cartons		9L,9H,OL,OH,1L,1H	49-51
8M 19560-B	NS	Kit-caulking strip-carton (80 ft)-replaced by 8M-19560-A		9L,9H,OL,OH,1L,1H	49-51
8L 19575-A	NS	Grease (distributor)-4 oz.-replaced by 8L-19575-B		9L,9H,OL,OH,1L,1H	49-51
8L 19575-B		Grease (distributor)-case of (12) 4 oz. tubes		9L,9H,OL,OH,1L,1H	49-51
8L 19582-A		Fluid (HYDRA-MATIC trans.)-54 gal. drum		9L,9H,OL,OH,1L,1H	49-51
8L 19582-B		Fluid (HYDRA-MATIC trans.)-5 gal. can		9L,9H,OL,OH,1L,1H	49-51
8L 19582-C	NS	Fluid (HYDRA-MATIC trans.)-1 qt. can-replaced by 8L-19582-D		9L,9H,OL,OH,1L,1H	49-51
8L 19582-D		Fluid (HYDRA-MATIC trans.)-case of (24) quart cans		9L,9H,OL,OH,1L,1H	49-51
8L 19585-A	NS	Grease (wheel bearing)-5 lb.-replaced by 8L-19585-B		9L,9H,OL,OH,1L,1H	49-51
8L 19585-B		Grease (wheel bearing)-case of (6) 5 lb. cans		9L,9H,OL,OH,1L,1H	49-51
8L 19586-A	NS	Lubriplate-2 oz. tube replaced by 8L-19586-B		9L,9H,OL,OH,1L,1H	49-51
8L 19586-B		Lubriplate-used for lubricating door bumpers, locks etc.-case of (12) 2 oz. tubes		9L,9H,OL,OH,1L,1H	49-51
HCCA 19587-A		Lubricant (hypoid)-rear axle break-in 35 lb. pail		9L,9H,OL,OH,1L,1H	49-51

# Lincoln and Lincoln Cosmopolitan

## CHASSIS PARTS CATALOGUE

PART NUMBER	PART NAME	NO. REQ'D	MODEL	YEAR 19__
<b>Numerical Listing of Chassis Five Digit Part Numbers</b>				
8L 22009	Kit (brake spring repair)	1	9L,9H,OL,OH,1L,1H	49-51
8L 33576	Bearing (steering gear shaft)-needle point rollers type	1	9L,9H,OL,OH,1L,1H	49-51
OH 33677-A	Boot (steering column to instrument panel)-Rubber	1	OH	50
OH 33677-B	Boot (steering column to instrument panel)-Rubber	1	OH	50
OL 33677-A	Boot (steering column to instrument panel)-Rubber	1	OL	50
OL 33677-B	Boot (steering column to instrument panel)-Rubber	1	OL	50
OL 33680	Anti squeak (steering column saddle)-Fibre	1	OL,OH,1L,1H	50-51
8M 55027	Guard (front cross member)-"V" shaped	1	9L,9H,OL,OH,1L,1H	49-51
OM 55052	Retainer assy (speed grip nut)	8	OL,1L	50-51
8L 66073	"U" bolt (engine rear support)-1/2"-20 rolled thread	1	9L,9H	49
8L 77008	Bolt (flywheel housing to transmission)	4	9L,9H,OL,OH,1L,1H	49-51
8L 77011	Pan assy (transmission oil)	1	9L,9H,OL,OH,1L,1H	49-51
8L 77014	Gasket (transmission oil pan)	1	9L,9H,OL,OH,1L,1H	49-51
8L 77016	Screen assy (trans. oil pump intake)	1	9L,9H,OL,OH,1L,1H	49-51
8L 77017	Gear and shaft assy (trans. main drive)	1	9L,9H,OL,OH,1L,1H	49-51
8L 77019	Indicator assy (transmission oil level)	1	9L,9H,OL,OH,1L,1H	49-51
8L 77020	Tube (transmission oil filler)	1	9L,9H,OL,OH,1L,1H	49-51
8L 77022	Gasket (transmission case front cover)	1	9L,9H,OL,OH,1L,1H	49-51
8L 77027	Sleeve assy (trans. oil supply to clutches)	1	9L,9H,OL,OH,1L,1H	49-51
8L 77031	Plate (trans. center bearing cap lock)	1	9L,9H,OL,OH,1L,1H	49-51
8L 77032-A	Washer (trans. mainshaft thrust)-rear-.055"/.059" thick	as reqd	9L,9H,OL,OH,1L,1H	49-51
8L 77032-B	Washer (trans. mainshaft thrust)-rear-.063"/.067" thick	as reqd	9L,9H,OL,OH,1L,1H	49-51
8L 77032-C	Washer (trans. mainshaft thrust)-rear-.071"/.075" thick	as reqd	9L,9H,OL,OH,1L,1H	49-51
8L 77032-D	Washer (trans. mainshaft thrust)-rear-.079"/.083" thick	as reqd	9L,9H,OL,OH,1L,1H	49-51
8L 77032-E	Washer (trans. mainshaft thrust)-rear-.087"/.091" thick	as reqd	9L,9H,OL,OH,1L,1H	49-51
8L 77032-F	Washer (trans. mainshaft thrust)-rear-.095"/.099" thick	as reqd	9L,9H,OL,OH,1L,1H	49-51
8L 77032-G	Washer (trans. mainshaft thrust)-rear-.103"/.107" thick	as reqd	9L,9H,OL,OH,1L,1H	49-51
8L 77032-H	Washer (trans. mainshaft thrust)-rear-.111"/.115" thick	as reqd	9L,9H,OL,OH,1L,1H	49-51
8L 77061	Shaft assy (trans. output)-with snap ring groove	1	9L,9H,OL,OH	49-50
OL 77061	Shaft assy (trans. output)-less snap ring groove	1	9L,9H,OL,OH,1L,1H	49-51
1L 77061-A	Shaft assy (trans. output)-with 45° spline end	1	1L,1H	51
8L 77069	Snap ring (transmission output shaft center bearing retainer)	1	9L,9H,OL,OH,1L,1H	49-51
8L 77072	Gear (rear internal)	1	9L,9H,OL,OH,1L,1H	49-51
1L 77072-A	Gear (rear internal)	1	1L,1H	51
8L 77077	Screw (fillister head)-No. 10-24 x 1"	2	9L,9H,OL,OH,1L,1H	49-51

# Lincoln and Lincoln Cosmopolitan

## CHASSIS PARTS CATALOGUE

PART NUMBER	CLASS	PART NAME	NO. REQ'D	MODEL	YEAR 19
<b>Numerical Listing of Chassis Five Digit Part Numbers—Continued</b>					
8L 77126		Screw & washer assy (fillister hd)-No. 10-24 x 1"- front valve body to inner valve body	3	9L,9H,OL,OH,1L,1H	49-51
8L 77127		Screw and washer assy (fillister head)-No. 10-24 x 7/16"-front valve body cover plate	3	9L,9H,OL,OH,1L,1H	49-51
8L 77127		Screw and washer assy (fillister head)-No. 10-24 x 7/16"-outer valve body front cover	3	9L,9H,OL,OH,1L,1H	49-51
OL 77129		Piston (trans. reverse shifter block)	1	9L,9H,OL,OH,1L,1H	49-51
8L 77133		Support (trans. reverse internal gear)-with 5 bolt holes	1	9L,9H,OL,OH	49-50
OL 77133		Support (trans. reverse internal gear)-with 4 bolt holes	1	9L,9H,OL,OH,1L,1H	49-51
8L 77134		Spring (trans. reverse anchor retractor)-15/64" O.D. x 1-29/32" free length	1	9L,9H,OL,OH,1L,1H	49-51
8L 77135		Lock (trans. reverse anchor support bolt)	1	9L,9H,OL,OH,1L,1H	49-51
8L 77136		Bolt (hex special)-7/16"-20 x 3-3/64" overall length -transmission reverse anchor support	1	9L,9H,OL,OH,1L,1H	49-51
8L 77137		Pawl (transmission reverse gear anchor)	1	9L,9H,OL,OH,1L,1H	49-51
8L 77138		Snap ring (trans. reverse internal gear retaining)	1	9L,9H,OL,OH,1L,1H	49-51
1L 77138-A		Cover (trans. extension housing access)	1	1L,1H	51
8L 77139		Gear (transmission reverse internal)	1	9L,9H,OL,OH,1L,1H	49-51
1L 77139-A		Gear (transmission reverse internal)	1	1L,1H	51
8L 77140		Carrier assy (transmission reverse planet)	1	9L,9H,OL,OH,1L,1H	49-51
1L 77140-A		Carrier assy (transmission reverse planet)	1	1L,1H	51
8L 77141		Bearing assy (trans. output shaft)	1	9L,9H,OL,OH,1L,1H	49-51
8L 77142		Snap ring (trans. rear oil pump gear retaining)	1	9L,9H,OL,OH,1L,1H	49-51
8L 77144		Bearing (needle)-servo actuating lever pin	18	9L,9H,OL,OH,1L,1H	49-51
1L 77146-A		Washer (trans. reverse internal gear thrust)-3-1/4" O.D. x 2-9/16" I.D. x 3/32" thick	1	1L,1H	51
8L 77148		Snap ring (transmission reverse planet carrier retaining)	1	9L,9H,OL,OH,1L,1H	49-51
8L 77152		Gear (trans. rear oil pump drive)	1	9L,9H,OL,OH,1L,1H	49-51
8L 77153		Washer (trans. reverse sun gear thrust)-Bronze- 1-11/16" I.D. x 2-19/32" O.D. x .087"/.091" thick	1	9L,9H,OL,OH,1L,1H	49-51
8L 77154		Washer (trans. reverse sun gear backing thrust)- Steel-1-1/2" I.D. x 2-7/16" O.D. x .049"/.052" thick	1	9L,9H,OL,OH,1L,1H	49-51
1L 77155-A		Spring (trans. reverse blocker piston)-5/16" O.D.- 15/16" free length	1	1L,1H	51
1L 77161-A		Gasket (trans. extension housing access cover)	1	1L,1H	51
1L 77163-A		Piston (transmission reverse)	1	1L,1H	51
1L 77164-A		Pin (trans. reverse blocker piston stop)-1/8" dia. x 1-5/16" long	1	1L,1H	51
HBK 77167-A		Kit (trans. reverse clutch piston seals)	1	1L,1H	51
8L 77170		Gear & flange assy (trans. reverse sun)	1	9L,9H,OL,OH,1L,1H	49-51
1L 77179-A		Spacer (trans. reverse planet carrier)-1-11/16" O.D. x 1-25/64" I.D. x 23/64" thick	1	1L,1H	51
8L 77180		Carrier assy (transmission front planet)-complete	1	9L,9H,OL,OH	49-50
OL 77180		Carrier assy (trans. front planet)-complete	1	9L,9H,OL,OH,1L,1H	49-51

# Lincoln and Lincoln Cosmopolitan

## CHASSIS PARTS CATALOGUE

PART NUMBER	PART NAME	NO. REQ'D	MODEL	YEAR
<b>Numerical Listing of Chassis Five Digit Part Numbers—Continued</b>				
8L 77184	Washer (trans. front planetary assy front backing)	1	9L,9H,OL,OH,1L,1H	49-51
8L 77187	Drum assy (trans. rear clutch)	1	9L,9H,OL,OH	49-50
1L 77187-A	Drum assy (trans. rear clutch)	1	9L,9H,OL,OH,1L,1H	49-51
8L 77189	Washer (trans. front clutch drum rear thrust)	2	9L,9H,OL,OH,1L,1H	49-51
8L 77190	Washer (trans. front planetary assy front thrust)- Bronze-1-13/32" I.D. x 1-53/64" O.D. x .087"/.091" thick	1	9L,9H,OL,OH,1L,1H	49-51
OL 77201	Valve assy (trans. control)	1	9L,9H,OL,OH,1L,1H	49-51
1L 77201-A	Valve assy (trans. oil control)	1	1L,1H	51
8L 77211	Kit (transmission throttle shaft repair)	1	9L,9H,OL,OH	49-50
8L 77226	Bolt & washer assy (hex)-1/4"-20 x 1/2"-trans. side cover to case	5	9L,9H,OL,OH,1L,1H	49-51
8L 77231	Valve (trans. fourth to third speed down shift)	1	9L,9H,OL,OH,1L,1H	49-51
8L 77232	Retainer (trans. fourth to third speed down shift valve)-with 7/16" inside loop diameter	1	9L,9H,OL,OH,1L,1H	49-51
1L 77232-A	Retainer (trans. fourth to third speed down shift valve)-with 17/32" inside loop diameter	1	9L,9H,OL,OH,1L,1H	49-51
8L 77234	Lever assy (trans. inside detent control)	1	9L,9H,OL,OH,1L,1H	49-51
1L 77234-A	Lever assy (trans. inside detent control)	1	1L,1H	51
8L 77284	Lever (trans. inside throttle valve control)	1	9L,9H,OL,OH,1L,1H	49-51
1L 77285-A	Retainer assy (trans. detent plunger)	1	1L,1H	51
8L 77291	Shim (transmission reverse shifter bracket)-Steel- .006"/.008" thick	1 to 6	9L,9H,OL,OH,1L,1H	49-51
8L 77294	Piston (trans. reverse shifter blocker)	1	9L,9H,OL,OH	49-50
1L 77294-A	Piston (trans. reverse shifter blocker)	1	1L,1H	51
8L 77295	Bracket & crank assy (trans. reverse shifter)	1	9L,9H,OL,OH	49-50
OL 77295	Bracket and crank assy (trans. reverse shifter)	1	9L,9H,OL,OH,1L,1H	49-51
1L 77295-A	Bracket and crank assy (trans. reverse shifter)	1	1L,1H	51
8L 77299	Roller (trans. reverse shifter crank)	1	9L,9H,OL,OH,1L,1H	49-51
1L 77311-A	Pawl (trans. parking)	1	1L,1H	51
1L 77312-A	Bolt (hex-hd-dog point)-7/16"-20 x 2-61/64"-trans. parking pawl support	1	1L,1H	51
1L 77313-A	Spring (trans. parking brake pawl return)-18 coils- 1-3/4" long	1	1L,1H	51
8L 77320	Plate (trans. oil pump inlet pipe bolt)	2	9L,9H,OL,OH,1L,1H	49-51
8L 77321	Pipe assy (trans. front oil pump inlet)	1	9L,9H,OL,OH,1L,1H	49-51
1L 77325-B	Spring (trans. parking blocker piston)-11/32" O.D.- 1-1/32" free length	1	1L,1H	51
1L 77327-B	Stop (trans. parking blocker piston spring)	1	1L,1H	51
1L 77328-A	Piston (trans. parking blocker)-11/16" O.D. x 13/16" long	1	1L,1H	51
8L 77330	Kit (transmission front pump screws and washers)	1	9L,9H,OL,OH	49-50
HBK 77330-A	Kit (transmission front pump screws and washers)	1	1L,1H	51

# Lincoln and Lincoln Cosmopolitan

## CHASSIS PARTS CATALOGUE

PART NUMBER	PART NAME	NO. REQ'D	MODEL	YEAR
<b>Numerical Listing of Chassis Five Digit Part Numbers—Continued</b>				
8L 77331	Pump assy (transmission front oil)	1	9L,9H	49
OL 77331	Pump assy (trans. front oil)-with "905" cast on pump body	1	9L,9H,OL,OH,1L,1H	49-51
1L 77331-A	Pump assy (trans. front oil)	1	1L,1H	51
8L 77333	Valve (trans. front pump by pass)-1/2" O.D. x 13/32" I.D. x 5/8" long	1	9L,9H,OL,OH,1L,1H	49-51
1L 77333-A	Valve (trans. front pump by-pass)-9/16" O.D. x 15/32" I.D. x 5/8" long	1	1L,1H	51
8L 77334	Seal (transmission front cover oil)	1	9L,9H,OL,OH,1L,1H	49-51
8L 77336	Washer (trans. front cover to pump screw)-Copper-17/64" I.D.-3/8" O.D.-1/32" thick	3	9L,9H,OL,OH,1L,1H	49-51
8L 77337	Gear (transmission front drive)	1	9L,9H,OL,OH	49-50
OL 77337	Gear assy (trans. front drive)	1	9L,9H,OL,OH,1L,1H	49-51
8L 77340	Ring (transmission front oil pump seal)	2	9L,9H,OL,OH,1L,1H	49-51
8L 77342	Washer (trans. front pump locating)-Steel-21/64" I.D.-1/2" O.D.-3/32" thick	1	9L,9H,OL,OH,1L,1H	49-51
8L 77346	Gasket (trans. front pump intake pipe)	1	9L,9H,OL,OH,1L,1H	49-51
8L 77347	Key (woodruff)-.188"/.189" thick-trans. front pump drive	1	9L,9H,OL,OH,1L,1H	49-51
8L 77348	Pipe (trans. front oil pump delivery)-3-15/16" overall length	1	9L,9H,OL,OH,1L,1H	49-51
8L 77351	Pump assy (transmission rear oil)	1	9L,9H,OL,OH,1L,1H	49-51
8L 77353	Cover (transmission rear oil pump)	1	9L,9H,OL,OH,1L,1H	49-51
OL 77354	Plug (trans. throttle valve pressure regulator)	1	OL,OH,1L,1H	50-51
OL 77355	Seal (transmission pressure regulator to case)	1	OL,OH,1L,1H	50-51
8L 77360	Kit (transmission rear oil pump driven gear)	1	9L,9H,OL,OH	49-50
8L 77366	Pipe assy (transmission rear oil pump discharge)-8-1/8" developed length	1	9L,9H,OL,OH	49-50
OL 77366	Pipe (trans. rear oil pump discharge)-8-3/8" developed length-less fittings	1	OL,OH,1L,1H	50-51
8L 77382	Gasket (trans. pressure regulator to case)-Fibre-1-5/64" I.D.-1-5/16" O.D.-3/32" thick	1	9L,9H,OL,OH	49-50
OL 77382	Gasket (trans. pressure regulator to case)-Copper	1	OL,OH,1L,1H	50-51
8L 77383	Plug assy (trans. pressure regulator valve)	1	9L,9H,OL,OH	49-50
OL 77383	Plug assy (trans. pressure regulator valve)	1	OL,OH,1L,1H	50-51
HEK 77383-A	Kit (trans. pressure regulator plugs and gaskets)	1	1L,1H	51
8L 77385	Valve (transmission front pump pressure regulator)	1	9L,9H,OL,OH,1L,1H	49-51
8L 77387	Spring (trans. oil pressure regulator)-approximately 3-31/32" free length	1	9L,9H,OL,OH	49-50
OL 77387	Spring (trans. oil pressure regulator)-approximately 2-7/16" free length	1	OL,OH,1L,1H	50-51
1L 77387-A	Spring (trans. oil pressure regulator)-3/4" O.D.-2-21/32" free length	1	1L,1H	51
8L 77388	Kit (transmission governor drive flange)	1	9L,9H,OL,OH	49-50

# Lincoln and Lincoln Cosmopolitan

## CHASSIS PARTS CATALOGUE

PART NUMBER	PART NAME	NO. REQ'D	MODEL	YEAR 19__
<b>Numerical Listing of Chassis Five Digit Part Numbers—Continued</b>				
8L 77390	Governor assy (transmission)	1	9L,9H,OL,OH	49-50
OL 77390	Governor assy (transmission)	1	9L,9H,OL,OH,1L,1H	49-51
1L 77390-A	Governor assy (transmission)	1	1L,1H	51
8L 77391	Plunger & bushing assy (trans. governor high speed)	1	9L,9H,OL,OH,1L,1H	49-51
8L 77394	Stop (governor plunger)	4	9L,9H,OL,OH,1L,1H	49-51
OL 77395	Spring (trans. front servo check valve)	1	OL,OH,1L,1H	50-51
OL 77397	Ring (trans. front servo band release piston oil)	1	OL,OH,1L,1H	50-51
8L 77400	Plug (transmission governor sleeve)	1	9L,9H,OL,OH,1L,1H	49-51
8L 77401	Pipe (trans. governor oil supply)	3	9L,9H,OL,OH,1L,1H	49-51
8L 77402	Sleeve (transmission governor oil delivery)	1	9L,9H,OL,OH,1L,1H	49-51
8L 77404	Body assy (transmission front servo)	1	9L,9H,OL,OH,1L,1H	49-51
8L 77408	Adapter (transmission rear pump tube)-55/64" length	1	9L,9H,OL,OH	49-50
OL 77408	Seat (trans. front servo rear pump tube)-25/32" length	1	OL,OH,1L,1H	50-51
1L 77409-A	Body assy (trans. front servo exhaust valve)	1	1L,1H	51
8L 77410	Piston assy (trans. front servo)	1	9L,9H,OL,OH	49-50
OL 77410	Piston assy (transmission front servo)	1	OL,OH,1L,1H	50-51
OL 77415	Body (transmission front servo)	1	OL,OH,1L,1H	50-51
8L 77418	Retainer (transmission front servo release spring)-1-11/16" diameter	1	9L,9H,OL,OH	49-50
OL 77418	Retainer (transmission front servo release spring)-1-13/16" diameter	1	OL,OH,1L,1H	50-51
8L 77419	Spring (trans. front pump by-pass valve)-3/8" O.D.-approximately 1-25/64" free length	1	9L,9H,OL,OH,1L,1H	49-51
1L 77419-A	Spring (trans. front pump by-pass valve)-27/64" O.D.-1-23/32" free length	1	1L,1H	51
8L 77424	Spring (trans. front servo retracting)-13/16" O.D.-approximately 1-33/64" free length	1	9L,9H,OL,OH,1L,1H	49-51
8L 77425	Spring (transmission front servo booster)-1-11/32" O.D.-approximately 61/64" free length	1	9L,9H,OL,OH,1L,1H	49-51
8L 77426	Pipe (trans. servo oil transfer)-1-3/16" long	1	9L,9H,OL,OH,1L,1H	49-51
8L 77428-B	Ring (trans. governor oil seal)-1-3/16" x 3/32"	4	9L,9H,OL,OH	49-50
8L 77429-B	Ring (oil seal)-1-1/4" x 3/32"	1	9L,9H,OL,OH	49-50
8L 77430	Ring (oil seal)-1-5/16" x 3/32"	1	9L,9H,OL,OH,1L,1H	49-51
8L 77431	Ring (trans. governor oil collector)	1	9L,9H,OL,OH,1L,1H	49-51
8L 77432-B	Ring (oil seal)-2" x 3/32"	4	9L,9H,OL,OH	49-50
8L 77434-B	Ring (oil seal)	1	9L,9H,OL,OH	49-50
8L 77435-B	Ring (oil seal)-2-1/4" x 3/32"	1	9L,9H,OL,OH	49-50
8L 77438	Ring (transmission rear servo accumulator oil seal)	1	9L,9H,OL,OH,1L,1H	49-51
8L 77444	Body assy (transmission rear servo)	1	9L,9H,OL,OH,1L,1H	49-51
1L 77444-A	Body assy (transmission rear servo)	1	1L,1H	51
8L 77448	Kit (transmission rear servo check valve)	1	9L,9H,OL,OH,1L,1H	49-51
8L 77450	Spring (transmission rear servo pressure)-5/8" O.D.-approximately 1-15/64" free length	1	9L,9H,OL,OH,1L,1H	49-51
8L 77452	Retainer (transmission rear servo spring)	1	9L,9H,OL,OH,1L,1H	49-51

# Lincoln and Lincoln Cosmopolitan

## CHASSIS PARTS CATALOGUE

PART NUMBER	PART NAME	NO. REQ'D	MODEL	YEAR 19__
8L 77453	Spring (transmission rear servo tension)-1-29/32" O.D.-approximately 4-1/4" free length	1	9L,9H,OL,OH,1L,1H	49-51
8L 77454	Body assy (trans. rear servo accumulator)	1	9L,9H,OL,OH,1L,1H	49-51
1L 77454-A	Body assy (transmission rear servo accumulator)	1	1L,1H	51
8L 77455	Spring (transmission rear servo)-inner-5/8" O.D.- approximately 3-25/32" free length	1	9L,9H,OL,OH,1L,1H	49-51
8L 77459	Spring (transmission rear servo booster)	1	9L,9H,OL,OH,1L,1H	49-51
8L 77460	Piston and stem assy (trans. rear servo accumulator)	1	9L,9H,OL,OH,1L,1H	49-51
8L 77465	Spring (transmission rear servo outer)-7/8" O.D.- approximately 3-15/32" free length	1	9L,9H,OL,OH,1L,1H	49-51
1L 77467-A	Tube (trans. pressure regulator reverse oil)	1	1L,1H	51
8L 77469	Plunger (trans. rear servo check valve)	1	9L,9H,OL,OH,1L,1H	49-51
8L 77470	Piston and stem assy (trans. rear servo booster)	1	9L,9H,OL,OH,1L,1H	49-51
8L 77475	Piston (trans. rear servo compensator)	1	9L,9H,OL,OH,1L,1H	49-51
HAK 77475-A	Kit (trans. rear servo compensator piston & spring)	1	9L,9H,OL,OH,1L,1H	49-51
8L 77476	Body assy (trans. oil control valve inner)	1	9L,9H,OL,OH,1L,1H	49-51
8L 77483	Plug assy (transmission oil pan drain)	1	9L,9H,OL,OH,1L,1H	49-51
8L 77485	Gasket (transmission oil pan drain plug)	1	9L,9H,OL,OH,1L,1H	49-51
8L 77510	Band assy (transmission front)	1	9L,9H,OL,OH,1L,1H	49-51
8L 77515	Stop (transmission band anchor)	2	9L,9H,OL,OH,1L,1H	49-51
8L 77516	Lever (transmission rear band actuating)	1	9L,9H,OL,OH,1L,1H	49-51
8L 77518	Band assy (transmission rear)	1	9L,9H,OL,OH,1L,1H	49-51
8L 77521	Pin (trans. rear band actuating lever)-.366"/.369" diameter-1-13/16" long	1	9L,9H,OL,OH,1L,1H	49-51
1L 77521-A	Pin (trans. rear band actuating lever)-3/8" dia. x 1-3/4" long-clevis	1	9L,9H,OL,OH,1L,1H	49-51
8L 77530	Washer (trans. front clutch drum rear backing)-Steel -1-3/8" I.D. x 1-15/16" O.D. x 3/32" thick	1	9L,9H,OL,OH,1L,1H	49-51
8L 77531	Piston (trans. front clutch cylinder)	1	9L,9H,OL,OH,1L,1H	49-51
8L 77532	Drum assy (transmission front clutch)	1	9L,9H,OL,OH,1L,1H	49-51
8L 77535	Kit (trans. clutch piston seal and expander)	2	9L,9H,OL,OH,1L,1H	49-51
8L 77536	Drum and pin assy (transmission front)	1	9L,9H,OL,OH,1L,1H	49-51
8L 77540	Piston (trans. front band release)-1-5/8" diameter	1	9L,9H,OL,OH	49-50
OL 77540	Piston (transmission front band release)-1-3/4" dia.	1	OL,OH,1L,1H	50-51
8L 77543	Cylinder (trans. front band release)-1-11/16" I.D. at base	1	9L,9H,OL,OH	49-50
OL 77543	Cylinder (trans. front band release)-1-13/16" I.D. at base	1	OL,OH,1L,1H	50-51
8L 77551	Plate (transmission clutch driven)	1	9L,9H,OL,OH,1L,1H	49-51
8L 77563	Plate assy (transmission clutch drive)	11	9L,9H,OL,OH,1L,1H	49-51
8L 77572	Piston (trans. rear clutch cylinder)	1	9L,9H,OL,OH,1L,1H	49-51
8L 77573	Drum & pin assy (trans. rear clutch)	1	9L,9H,OL,OH,1L,1H	49-51
1L 77573-A	Drum & pin assy (trans. rear clutch)	1	1L,1H	51



# Lincoln and Lincoln Cosmopolitan

## CHASSIS PARTS CATALOGUE

PART NUMBER	PART NAME	NO. REQ'D	MODEL	YEAR
<b>Numerical Listing of Chassis Five Digit Part Numbers—Continued</b>				
8L 77575	Pin (trans. rear clutch spring guide)-.116"/.122" diameter x 1-5/8" long	6	9L,9H,OL,OH,LL,1H	49-51
8L 77578	Spring (trans. clutch release)-inner-15/64" O.D.-approximately 2-15/64" free length	12	9L,9H,OL,OH,LL,1H	49-51
8L 77579	Hub (transmission rear clutch)	1	9L,9H,OL,OH,LL,1H	49-51
8L 77581	Washer (trans. rear clutch hub thrust)	2	9L,9H,OL,OH,LL,1H	49-51
8L 77582	Spring (trans. clutch release)-outer-3/8" O.D. x 2-31/64" free length	12	9L,9H,OL,OH,LL,1H	49-51
8L 77584	Ring (trans. rear clutch cylinder retaining)	2	9L,9H,OL,OH,LL,1H	49-51
1L 77590-A	Washer (trans. reverse clutch release spring retainer)-3-7/8" O.D. x 3-1/16" I.D.	1	1L,1H	51
1L 77591-A	Cone (trans. reverse clutch stationary)-6-13/16" O.D. x 29/32" width	1	1L,1H	51
1L 77592-A	Spring (trans. reverse clutch release)-3-7/8" O.D. x 3-1/8" I.D.	1	1L,1H	51
1L 77593-A	Tube (trans. reverse clutch oil)-3/8" O.D. x 6-7/16" length	1	1L,1H	51
1L 77594-A	Key (trans. reverse clutch stationary cone)-35/64" x 3/8" x 1/4"	1	1L,1H	51
1L 77595-A	Spring (trans. reverse clutch piston release)-15/32" O.D.-1-11/32" free length	6	1L,1H	51
1L 77596-A	Snap ring (trans. reverse clutch piston spring retainer)-3-1/4" O.D. x 2-7/8" I.D. x 1/16" thick	1	1L,1H	51
1L 77598-A	Retainer (trans. reverse clutch piston spring)-4-1/4" O.D. x 3-5/32" I.D. x 5/64" thick	1	1L,1H	51
8L 77601	Body assy (trans. oil control valve outer)	1	9L,9H,OL,OH	49-50
8L 77603	Valve (transmission manual control)-4-3/4" length	1	9L,9H,OL,OH,LL,1H	49-51
1L 77603-A	Valve (trans. manual control)-5-13/64" length	1	1L,1H	51
8L 77604	Plate (trans. valve body spacer)	1	9L,9H,OL,OH,LL,1H	49-51
8L 77605	Spring (trans. manual valve detent)-9/32" O.D.-approximately 1-25/64" free length	1	9L,9H,OL,OH,LL,1H	49-51
1L 77605-A	Spring (trans. manual valve detent)-13/64" O.D. x 1-21/64" free length	1	1L,1H	51
1L 77607-A	Plunger (trans. manual detent)-5/16" O.D. x 49/64" length	1	1L,1H	51
8L 77613	Retainer (trans. manual valve detent ball)	1	9L,9H,OL,OH,LL,1H	49-51
8L 77629	Screw and washer assy (fillister head)-No. 10-24 x 7/8"-outer valve body to detent retainer	1	9L,9H,OL,OH,LL,1H	49-51
8L 77631	Screw and washer assy (fillister head)-No. 10-24 x 3/4"-outer valve body to inner valve body	1	9L,9H,OL,OH,LL,1H	49-51
8L 77631	Screw and washer assy (fillister head)-No. 10-24 x 3/4"-inner valve body rear cover	3	9L,9H,OL,OH,LL,1H	49-51
8L 77632	Screw and washer assy (fillister head)-No. 10-24 x 5/8"-detent retainer to outer valve body	2	9L,9H,OL,OH,LL,1H	49-51
8L 77633	Screw and washer assy (fillister head)-No. 10-24 x 7/8"-outer valve body to inner valve body	1	9L,9H,OL,OH,LL,1H	49-51
8L 77769	Kit (trans. manual control shaft seal and washer)	1	9L,9H,OL,OH,LL,1H	49-51

# Lincoln and Lincoln Cosmopolitan

## CHASSIS PARTS CATALOGUE

PART NUMBER	PART NAME	NO. REQ'D	MODEL	YEAR 19__
<b>Numerical Listing of Chassis Five Digit Part Numbers—Continued</b>				
8EL 88502	Pump assy (water)-less pulley-RH-assemble 21541-S Bolt and 34807-S2 Lockwasher in pump prior to assembly of pulley	1	9L,9H,OL,OH,1L,1H	49-51
8EL 88503	Pump assy (water)-less pulley-LH-assemble 21541-S Bolt and 34807-S2 Lockwasher in pump prior to assembly of pulley	1	9L,9H,OL,OH,1L,1H	49-51
7RA 99355	Plate (vacuum pump cover)	1	9L,9H,OL,OH,1L,1H	49-51
7RA 99359	Seat (vacuum pump diaphragm spring)	1	9L,9H,OL,OH,1L,1H	49-51
8EL 99360	Kit (fuel pump strainer)	1	9L,9H,OL,OH	49-50
7RA 99361	Plate (vacuum pump valve retainer)	1	9L,9H,OL,OH,1L,1H	49-51
7RA 99366	Retainer (vacuum pump screen)	1	9L,9H,OL,OH,1L,1H	49-51
7RA 99367	Gasket (vacuum pump cover plate)	1	9L,9H,OL,OH,1L,1H	49-51
LBA 99367-A	Gasket (vacuum pump valve to body)	3	1L,1H	51
7RA 99368	Screen (vacuum pump)	1	9L,9H,OL,OH,1L,1H	49-51
8EL 99380	Link (vacuum pump rocker arm)-RH	1	9L,9H,OL,OH,1L,1H	49-51
1EL 99380-A	Link (vacuum pump rocker arm)-RH	1	1L,1H	51
8EL 99381	Link (vacuum pump rocker arm)-LH	1	9L,9H,OL,OH,1L,1H	49-51
1EL 99381-A	Link (vacuum pump rocker arm)-LH	1	1L,1H	51
8EL 99385	Body assy (vacuum pump)	1	9L,9H,OL,OH,1L,1H	49-51
1EL 99385-A	Body (vacuum pump)	1	1L,1H	51
8EL 99390	Diaphragm assy (vacuum pump)	1	9L,9H,OL,OH,1L,1H	49-51
1EL 99390-A	Diaphragm assy (vacuum pump)	1	1L,1H	51
8EL 99396	Spring (vacuum pump diaphragm)	1	9L,9H,OL,OH,1L,1H	49-51
1CM 99522	Screen and retainer assy (carburetor filter)	1	1L,1H	51
8EL 99523	Piston assy (carburetor automatic choke)	1	9L,9H,OL,OH,1L,1H	49-51
8CM 99525	Kit (carburetor float and float spring)	1	9L,9H,OL,OH	49-50
8CM 99526	Screen (carburetor filter)	1	9L,9H,OL,OH,1L,1H	49-51
8CM 99527	Spring (carburetor filter screen retainer)	1	9L,9H,OL,OH,1L,1H	49-51
8CM 99528	Retainer (carburetor filter spring)	1	9L,9H,OL,OH,1L,1H	49-51
OEL 99557	Shaft and lever assy (carburetor choke housing)	1	9L,9H,OL,OH	49-50
OEL 99622	Gasket (air cleaner element)	1	9L,9H,OL,OH,1L,1H	49-51
8L 99745	Bushing (accelerator bellcrank stud)	1	9L,9H,OL,OH,1L,1H	49-51
8L 99765-B	Plate and stud assy (accelerator bellcrank)	1	9L,9H,OL,OH,1L,1H	49-51
8L 99768-B	Spring (accelerator bellcrank)-approximately 1-9/16" free length	1	9L,9H,OL,OH,1L,1H	49-51
8L 99770-B	Seal (accelerator bellcrank)	2	9L,9H	49
OL 99770	Seal (accelerator bell crank)-inner	1	OL,OH,1L,1H	50-51
8L 99771	Bracket (accelerator bellcrank)-outer-approximately 6-1/8" overall length	1	9L,OL,1L	49-51
8H 99771	Bracket (accelerator bellcrank)-outer-approximately 6-23/32" overall length	1	9H,OH,1H	49-51
8L 99772-A	Shim (accelerator bellcrank bracket)-outer-Steel- .0299" thick	as reqd	9L,9H,OL,OH,1L,1H	49-51
8L 99772-B	Shim (accelerator bellcrank bracket)-outer-Steel- .0598" thick	as reqd	9L,9H,OL,OH,1L,1H	49-51
8L 99772-C	Shim (accelerator bellcrank bracket)-outer-Steel- .1196" thick	as reqd	9L,9H,OL,OH,1L,1H	49-51
OL 99773	Seal (accelerator bell crank)-outer	1	OL,OH,1L,1H	50-51



# Lincoln Cosmopolitan

## CHASSIS PARTS CATALOGUE

### ★ Numerical List of Standard Parts

PART NUMBER	PART NAME	PART NUMBER	PART NAME
20132-S2	1/2"-13 x 1-1/4" Hex. head bolt	24391-S7-8	7/16"-20 x 1" Hex. head bolt-pointed
20220-S	5/16"-18 x 2" Hex. head bolt	24404-S7	1/4"-20 x 1-1/8" Hex. head bolt-pointed
20222-S8	3/8"-16 x 2" Hex. head bolt	24427-S8	5/16"-24 x 1-1/4" Hex. head bolt-pointed
20246-S8	7/16"-14 x 2-1/2" Hex. head bolt	24429-S7	3/8"-24 x 1-1/4" Hex. head bolt-pointed
20247-S	7/16"-20 x 2-1/2" Hex. head bolt	24430-S8	7/16"-14 x 1-1/4" Hex. head bolt-pointed
20252-S2	1/2"-13 x 2-3/4" Hex. head bolt	24433-S7	1/2"-20 x 1-1/4" Hex. head bolt-pointed
20303-S8	5/16"-24 x 3/8" Hex. head bolt	24466-S7	5/16"-18 x 1-1/2" Hex. head bolt-pointed
20304-S2	1/4"-20 x 7/16" Hex. head bolt	24469-S7	3/8"-24 x 1-1/2" Hex. head bolt-pointed
20310-S8	5/16"-18 x 1/2" Hex. head bolt	24473-S7	1/2"-20 x 1-1/2" Hex. head bolt-pointed
20319-S7	5/16"-24 x 9/16" Hex. head bolt	24507-S7	3/8"-24 x 1-3/4" Hex. head bolt-pointed
20326-S7	5/16"-18 x 5/8" Hex. head bolt	24511-S7	1/2"-20 x 1-3/4" Hex. head bolt-pointed
20328-S	3/8"-16 x 5/8" Hex. head bolt	24523-S8	3/8"-24 x 2" Hex. head bolt-pointed
20345-S2	1/4"-28 x 3/4" Hex. head bolt	24541-S7	3/8"-24 x 2-3/8" Hex. head bolt-pointed
20350-S7	7/16"-14 x 3/4" Hex. head bolt	24666-S7	5/16"-18 x 3/4" Flat head machine bolt
20384-S2	1/4"-20 x 1" Hex. head bolt	25156-S8	1/2"-20 x 2-5/8" Hex. head bolt-wire size body
20392-S	1/2"-13 x 1" Hex. head bolt	25164-S8	1/2"-20 x 3-1/2" Hex. head bolt
20418-S	3/8"-16 x 1-3/16" Hex. head bolt	25168-S8	1/2"-20 x 4 Hex. head bolt-wire size body
20449-S2	3/8"-24 x 1-3/8" Hex. head bolt	25218-S8	No. 10-32 x 3/8" Flat head machine screw
20470-S8	7/16"-14 x 1-1/2" Hex. head bolt	25231-S7	No. 10-32 x 1/2" Flat head machine screw
20506-S7	3/8"-16 x 1-3/4" Hex. head bolt	26148-S	5/16"-18" x 3/8" Round head machine bolt
20525-S	7/16"-20 x 2" Hex. head bolt	26451-S7	No. 6-32 x 3/16" Round head machine screw
20550-S8	7/16"-14 x 2-3/4" Hex. head bolt	26452-S7	No. 8-32 x 3/16" Round head machine screw
20702-S	5/8"-18 x 1-7/16" Hex. head bolt	26455-S8	No. 4-40 x 1/4" Round head machine screw
20747-S7	5/8"-18 x 1-3/4" Hex. head bolt	26457-S7	No. 8-32 x 1/4" Round head machine screw
21481-S2	1/4"-20 x 1-3/4" Hex. head bolt-wire size body	26462-S7	No. 8-32 x 5/16" Round head machine screw
21492-S2	5/16"-24 x 1-7/8" Hex. head bolt-wire size body	26466-S6	No. 6-32 x 3/8" Round head machine screw
21556-S7	3/8"-24 x 3-1/4" Hex. head bolt	26479-S7	No. 6-32 x 1/2" Round head machine screw
21566-S7	3/8"-24 x 3-1/4" Hex. head bolt-wire size body	26498-S7	No. 12-24 x 5/8" Round head mach. bolt
22994-S8	1/4"-20 x 7/8" Square head bolt	26514-S2	No. 12-24 x 1-3/4" Round head mach. screw
23017-S16	5/16"-18 x 1-1/4" Square head bolt	27068-S8	No. 10-32 x 3/8" Round head mach. screw
23376-S	1/4"-20 x 3/4" Round head carriage bolt	27097-S2	No. 10-32 x 5/8" Round head mach. screw
23391-S2	1/4"-20 x 7/8" Round head carriage bolt	27113-S7	No. 10-32 x 3/4" Round head screw
23409-S7	5/16"-24 x 1" Round head carriage bolt	27145-S13	No. 10-32 x 1" Round head mach. screw
23426-S8	3/8"-24 x 1-1/8" Round head carriage bolt	27153-S7	No. 10-32 x 1-1/8" Round head mach. screw
23440-S8	3/8"-16 x 1-1/4" Round head carriage bolt	27177-S7	No. 10-32 x 1-1/2" Round head mach. screw
23441-S7	3/8"-24 x 1-1/4" Round head carriage bolt	27687-S	No. 8-32 x 3/16" Round head machine screw-Brass
24308-S7	1/4"-20 x 1/2" Hex. head bolt-pointed	28442-S13	No. 8-32 x 3/4" Oval head screw
24309-S8	1/4"-28 x 1/2" Hex. head bolt-pointed	29546-S13	No. 6-32 x 5/16" Oval head machine screw-Brass
24311-S8	5/16"-24 x 1/2" Hex. head bolt-pointed	30012-S13	No. 8-32 x 1/2" Oval head machine screw-pointed
24324-S7	1/2"-20 x 5/8" Hex. head bolt-pointed	30084-S13	No. 8-32 x 1-1/8" Oval head machine screw-pointed
24325-S8	1/4"-28 x 5/8" Hex. head bolt-pointed	31061-S8	No. 8-32 x 1/2" Fillister hd mach. screw
24327-S7	5/16"-24 x 5/8" Hex. head bolt-pointed	31077-S8	No. 8-32 x 5/8" Fillister hd mach. screw
24336-S7	5/16"-18 x 11/16" Hex. head bolt-pointed	31079-S7	No. 12-24 x 5/8" Fillister hd mach. screw
24344-S7	1/4"-20 x 3/4" Hex. head bolt-pointed	31144-S7	1/4"-20 x 1-1/4" Fillister hd mach. screw
24346-S7	5/16"-18 x 3/4" Hex. head bolt-pointed	31477-S2	No. 14-10 x 1/2" Pan head self tap. screw
24347-S8	5/16"-24 x 3/4" Hex. head bolt-pointed	31497-S7	No. 14-10 x 1/2" Hex. washer head self tapping screw
24348-S8	3/8"-16 x 3/4" Hex. head bolt-pointed	31498-S8	No. 14-10 x 5/8" Hex. washer head self tapping screw
24349-S7	3/8"-24 x 3/4" Hex. head bolt-pointed		
24386-S8	5/16"-18 x 1" Hex. head bolt-pointed		
24387-S7	5/16"-24 x 1" Hex. head bolt-pointed		
24388-S8	3/8"-16 x 1" Hex. head bolt-pointed		
24389-S8	3/8"-24 x 1" Hex. head bolt-pointed		

\* For additional information refer to Lincoln-Mercury Standard Parts Catalogue Form LM-3733

# Lincoln and Lincoln Cosmopolitan

## CHASSIS PARTS CATALOGUE

### \*Numerical List of Standard Parts—Continued

PART NUMBER	PART NAME	PART NUMBER	PART NAME
31522-S7	No. 14-14 x 3/8" Slotted hex. head self tapping screw	34393-S7	5/16"-24 Free running lock nut
31527-S7	No. 14-14 x 1/2" Hex. washer head self tapping screw	34395-S7	3/8"-24 Free running lock nut
31596-S7	No. 10-32 x 3/8" Fillister hd mach. screw	34397-S7	7/16"-20 Free running lock nut
31598-S	1/4"-28 x 3/8" Fillister hd mach. screw	34399-S8	1/2"-20 Free running lock nut
31628-S7	No. 10-32 x 5/8" Fillister hd mach. screw	34424-S7	1/2"-20 Prevailing turque lock nut
32853-S7	No. 12-11 x 3/8" Round hd self tap.screw	34443-S7	5/16"-24 Prevailing turque lock nut
32859-S7	No. 10-12 x 1/2" Round hd self tap.screw	34445-S7	3/8"-24 Prevailing turque lock nut
32859-S13	No. 10-12 x 1/2" Round hd self tap.screw	34447-S2	7/16"-20 Prevailing turque lock nut
32873-S7	No. 10-12 x 3/4" Round Hd self tap.screw	34449-S7	1/2"-20 Prevailing turque lock nut
32889-S8	No. 10-12 x 1-1/4" Rd-hd self tap.screw	34451-S	9/16"-18 Prevailing turque lock nut
32909-S8	No. 8-15 x 1/4" Pan head self tap. screw	34701-S23	No. 6 Flat washer
32914-S8	No. 6-18 x 3/8" Pan head self tap.screw	34707-S2	3/8" (5/64" x 1") Flat washer
32916-S8	No. 8-15 x 3/8" Pan head self tap.screw	34761-S7	5/8" (3/32" x 1-5/16") Flat washer
32917-S13	No. 10-12 x 3/8" Pan head self tap.screw	34801-S7	No. 6 (1/32" x 1/4") Lockwasher
32924-S8	No. 10-12 x 1/2" Pan head self tap.screw	34802-S7	No. 8 (3/64" x 17/64") Lockwasher
32938-S7	No. 10-12 x 3/4" Pan head self tap.screw	34803-S7	No. 10 (3/64" x 21/64") Lockwasher
32944-S2	No. 10-12 x 7/8" Pan head self tap.screw	34804-S8	No. 12 (1/16" x 3/8") Lockwasher
33104-S8	No. 8-18 x 1/4" Round head self tap.screw	34805-S8	1/4" (1/16" x 15/32") Lockwasher
33121-S8	No. 14-14 x 1/2" Round hd self tap.screw	34806-S7	5/16" (1/16" x 19/32") Lockwasher
33169-S7	No. 8-18 x 1/4" Pan head self tap.screw	34807-S2	3/8" (3/32" x 21/32") Lockwasher
33170-S7	No. 10-16 x 1/4" Pan head self tap.screw	34808-S8	7/16" (1/8" x 25/32") Lockwasher
33206-S7	No. 14-14 x 7/8" Pan head self tap.screw	34809-S8	1/2" (1/8" x 7/8") Lockwasher
33427-S7	No. 6-20 x 1/4" Pan head self tap.screw	34810-S7	9/16" (1/8" x 31/32") Lockwasher
33444-S2	No. 10-16 x 1/2" Pan head self tap.screw	34811-S2	5/8" (5/32" x 1-1/16") Lockwasher
33795-S7	1/4"-20 (7/32" x 7/16") Hex. nut	34814-S	7/8" (7/32" x 1-15/32") Lockwasher
33796-S7	1/4"-28 (7/32" x 7/16")-Hex. nut	34822-S7	No. 8 (1/32" x 1/4") Lockwasher-light
33797-S7	5/16"-18 (17/64" x 1/2") Hex. nut	34823-S2	No. 10 (3/64" x 21/64") Lockwasher-light
33797-S16	5/16"-18 (17/64" x 1/2") Hex. nut	34825-S8	1/4" (3/64" x 31/64") Lockwasher-light
33798-S8	5/16"-24 (17/64" x 1/2") Hex. nut	34826-S7	5/16" (3/64" x 19/32") Lockwasher-light
33799-S7	3/8"-16 (21/64" x 9/16") Hex. nut	34827-S2	3/8" (1/16" x 43/64") Lockwasher-heavy
33800-S8	3/8"-24 (21/64" x 9/16") Hex. nut	34829-S2	1/2" (1/16" x 7/8") Lockwasher-heavy
33802-S8	7/16"-20 (3/8" x 5/8") Hex. nut	34846-S2	5/16" (3/32" x 19/32") Lockwasher-heavy
33816-S	7/16"-20 (3/8" x 5/8") Hex. nut	34849-S2	1/2" (5/32" x 57/64") Lockwasher-heavy
33846-S8	1/2"-20 (7/16" x 3/4") Hex. nut	34850-S	9/16" Lockwasher
33848-S7	9/16"-18 (31/64" x 7/8") Hex. nut	34851-S7	5/8" (3/16" x 41/64") Lockwasher-heavy
33850-S2	5/8"-18 (35/64" x 15/16") Hex. nut	34901-S7	No. 6 (1/64" x 9/32") Internal tooth lockwasher
33907-S8	1/4"-28 Hex. check nut	34902-S8	1/4" (1/64" x 21/64") Internal tooth lockwasher
33920-S	1/4"-20 (5/32" x 7/16") Hex. nut	34903-S8	No. 10 (1/64" x 3/8") Internal tooth lockwasher
33921-S13	1/4"-28 (5/32" x 7/16") Hex. check nut	34904-S2	No. 12 (1/64" x 13/32") Internal tooth lockwasher
33922-S2	5/16"-18 (3/16" x 1/2") Hex. check nut	34905-S7	1/4" (1/64" x 15/32") Internal tooth lockwasher
33923-S7	5/16"-24 (7/32" x 9/16") Hex. check nut	34906-S8	5/16" (1/32" x 39/64") Internal tooth lockwasher
33929-S7	1/2"-20 (5/16" x 3/4") Hex. check nut	34907-S7	3/8" (1/32" x 11/16") Internal tooth lockwasher
33983-S7	1/2"-20 (7/16" x 3/4") Hex. slotted nut	34908-S2	7/16" (1/32" x 3/4") Internal tooth lockwasher
34032-S7	1/2"-20 (9/16" x 3/4") Castle nut	34909-S7	1/2" (1/32" x 57/64") Internal tooth lockwasher
34051-S7	No. 6-32 (7/64" x 5/16") Hex. nut	34910-S2	9/16" (1/32" x 31/32") Internal tooth lockwasher
34052-S7	No. 8-32 (1/8" 11/32") Hex. nut		
34053-S8	No. 10-24 Hex. common nut		
34054-S8	No. 12-24 (5/32" x 7/16") Hex. nut		
34079-S7	No. 10-32 (1/8" x 3/8") Hex. nut		
34081-S7	1/4"-28 (3/16" x 7/16") Hex. nut		
34370-S8	3/8"-24 Free running lock nut		
34390-S7	1/4"-20 Free running lock nut		
34392-S7	5/16"-18 Free running lock nut		

# Lincoln and Lincoln Cosmopolitan

## CHASSIS PARTS CATALOGUE

### \*Numerical List of Standard Parts—Continued

PART NUMBER	PART NAME	PART NUMBER	PART NAME
34913-S8	3/4" (3/64" x 1-15/64") Internal tooth lockwasher	41800-S8	No. 6-32 x 1/4" Flat head self tap.screw
34922-S	1/2" (1/16" x 59/64") Internal tooth lockwasher	42007-S8	No. 10-12 x 1/2" Hex.head self tap. screw
34937-S7	No. 6 (1/64" x 5/16") External tooth lockwasher	42014-S8	No. 10-12 x 5/8" Hex.head self tap. screw
34938-S8	No. 8 (1/64" x 3/8") External tooth lockwasher	42021-S8	No. 10-12 x 3/4" Hex.head self tap. screw
34940-S2	1/4" (1/64" x 1/2") External tooth lockwasher	42023-S7	No. 14-10 x 3/4" Hex-hd self tap. screw
34941-S7	5/16" (1/32" x 39/64") External tooth lockwasher	42032-S8	No. 10-12 x 1" Hex-hd self tap. screw
34944-S2	1/2" (3/64" x 57/64") External tooth lockwasher	42037-S8	No. 10-20 x 1-1/4" Hex-hd self tap. screw
35999-S7	No. 8-32 x 1/2" Fl-hd mach. screw-pointed	42134-S8	No. 10-12 x 5/8" Hex. washer head self tapping screw
36103-S7	5/16"-18 x 1-1/8" Fl-hd mach.bolt-pointed	42143-S8	No. 14-10 x 3/4" Hex. washer head self tapping screw
36782-S7	No. 6-32 x 1/4" Round head screw	42360-S7	No. 10-16 x 3/16" Hex. washer head self tapping screw
36787-S7	No. 6-32 x 5/16" Rd-hd mach.screw-pointed	42649-S8	No. 8-32 x 3/8" Round head screw and lockwasher assy
37611-S7	No. 8-32 x 1/4" Fillister head machine screw-pointed	42672-S8	No. 10-32 x 3/8" Fillister head screw and lockwasher assy
37624-S7	No. 12-24 x 5/16" Fillister head machine screw-pointed	42728-S8	No. 10-32 x 1/2" Hex. head screw and lockwasher assy
37643-S7	No. 6-32 x 7/16" Fillister head screw-pointed	42783-S8	3/8"-24 x 7/8" Hex. head bolt and external tooth lockwasher
37657-S8	No. 12-24 x 1/2" Fillister head machine screw-pointed	42789-S8	5/16"-18 x 3/4" Hex. head bolt and lockwasher assy
38018-S	No. 8-32 x 5/16" Fillister head machine screw-pointed-Brass	42802-S8	No. 10-32 x 3/8" Pan head screw and lockwasher assy
39075-S8	5/16"-24 x 5/8" Pan head machine bolt -pointed	42817-S8	1/4"-20 x 1/2" Pan head bolt and lockwasher assy
39909-S7	5/16"-18 x 3/4" Hex. washer head self tapping screw	42904-S8	1/4"-28 x 5/8" Hex. head screw and lockwasher assy
40156-S8	5/16"-18 x 5/8" Hex. head self tap.screw	42905-S8	5/16"-24 x 3/4" Hex. head bolt and lockwasher assy
40500-S8	No. 6-32 x 1/4" Pan head self tapping screw	42906-S8	1/4"-20 x 3/4" Hex. head bolt and lockwasher assy
40516-S8	No. 10-32 x 3/8" Pan head self tapping screw	42911-S	1/4"-20 x 5/8" Hex-hd self locking bolt
40542-S8	No. 10-32 x 5/8" Pan head self tapping screw	42952-S	5/16"-18 x 1/2" Hex-hd self locking bolt
40631-S8	No. 8-32 x 1/4" Round head self tap.screw	43243-S8	No. 8-32 x 3/4" Pan hd screw & L/W assy
40921-S8	1/4"-20 x 1/2" Hex. head tapping screw	43260-S8	1/4"-20 x 1/2" Hex-hd bolt and L/W assy
40969-S8	No. 8-32 x 1" Hex washer head self tapping screw	43261-S8	1/4"-20 x 7/8" Hex-hd bolt and L/W assy
40995-S8	No. 8-32 x 1-1/2" Hex washer head self tapping screw	43262-S8	5/16"-24 x 7/8" Fillister head bolt and lockwasher assy
41036-S8	No. 10-32 x 3/8" Hex. head self tap.screw	43263-S8	1/4"-20 x 5/8" Hex-hd bolt and L/W assy
41178-S8	No. 10-24 x 1/2" Hex. head self tap.screw	43264-S8	5/16"-24 x 7/8" Hex-hd bolt and L/W assy
41181-S8	1/4"-20 x 1/2" Hex.head self tap. screw	43377-S8	No. 6-32 x 1/2" Pan head screw and lockwasher assy
41220-S8	1/4"-20 x 7/8" Hex-hd self tap. screw	44707-S8	No. 6 (3/64" x 3/8") Flat washer
41281-S8	No. 8-32 x 1/4" Fillister head self tapping screw	44713-S8	No. 10 (3/64" x 1/2") Flat washer
41294-S8	No. 8-32 x 3/8" Fillister head self tapping screw	44716-S8	No. 10 (3/64" x 9/16") Flat washer
41541-S8	No. 8-32 x 1/4" Pan head self tap.screw	44719-S8	1/4" (1/16" x 5/8") Flat washer
41556-S8	No. 10-32 x 3/8" Pan head self tap.screw	44720-S8	1/4" (1/16" x 3/4") Flat washer
		44722-S8	5/16" (1/16" x 11/16") Flat washer
		44724-S8	5/16" (3/32" x 7/8") Flat washer
		44726-S8	3/8" (1/16" x 13/16") Flat washer
		44728-S8	3/8" (3/32" x 1") Flat washer
		44730-S8	7/16" (5/64" x 59/64") Flat washer
		44734-S8	1/4" (3/32" x 1-1/16") Flat washer

# Lincoln and Lincoln Cosmopolitan

## CHASSIS PARTS CATALOGUE

### \* Numerical List of Standard Parts—Continued

PART NUMBER	PART NAME	PART NUMBER	PART NAME
44738-S8	9/16" (3/32" x 1-3/16") Flat washer	65041-S	5/16" x 3/4" Round head rivet-pointed
44815-S	No. 12 (1/2" x 1/16") Flat washer	65042-S	5/16" x 13/16" Round head rivet-pointed
45015-S8	No. 10A (1/2" x 3/4") Spring nut	65043-S	5/16" x 7/8" Round head rivet-pointed
45017-S32	No. 10-32 (11/16" x 1-3/8") Spring nut-flat type	65044-S	5/16" x 15/16" Rd-hd solid rivet-pointed
45191-S8	No. 10-12 (1/2" x 61/64") Spring nut "U" shape	65071-S	3/8" x 1-3/16" Round head rivet-pointed
45218-S8	3/8"-24 (9/64" x 9/16") Hex. stamped nut	65072-S	3/8" x 1-1/4" Round head rivet-pointed
45219-S	7/16"-20 (5/32" x 5/8") Hex. stamped nut	72003-S7	1/16" x 1/2" Cotter pin
50386-S13	No. 6-32 x 3/8" Cross recessed oval head machine screw	72004-S7	3/32" x 1/2" Cotter pin
50399-S23	No. 10-32 x 1/2" Cross recessed oval head machine screw	72009-S	3/32" x 5/8" Cotter pin
50804-S8	No. 10-32 x 3/8" Cross recessed pan head screw and lockwasher assy	72010-S	1/8" x 5/8" Cotter pin
50923-S8	No. 8-32 x 3/8" Cross recessed fillister head screw and lockwasher assy	72015-S	1/16" x 3/4" Cotter pin
50929-S8	No. 8-32 x 1/2" Cross recessed fillister head screw and lockwasher assy	72016-S8	3/32" x 3/4" Cotter pin
51145-S13	No. 6-32 x 1/4" Cross recessed flat head self tapping screw	72017-S	1/8" x 3/4" Cotter pin
51754-S8	No. 6-32 x 3/8" Cross recessed pan head self tapping screw	72035-S7	1/8" x 1" Cotter pin
51754-S8	No. 6-32 x 3/8" Cross recessed screw	72054-S	5/32" x 1-1/2" Cotter pin
52017-S8	No. 8-15 x 5/8" Cross recessed flat head self tapping screw	72070-S	3/32" x 1-1/2" Cotter pin
52018-S8	No. 10-12 x 5/8" Cross recessed flat head self tapping screw	72187-S7	1/16" x 1/2" Grooved pin
52342-S13	No. 6-18 x 1/2" Cross recessed oval head self tapping screw	72798-S	1/8" x 7/16" Straight pin
52345-S13	No. 10-12 x 1/2" Oval head screw	72867-S	1/8" x 7/8" Straight pin
52352-S13	No. 8-15 x 5/8" Cross recessed oval head self tapping screw	72869-S	3/16" x 7/8" Straight pin
52358-S23	No. 6-18 x 3/4" Cross recessed oval head self tapping screw	72909-S2	3/16" x 1-1/4" Straight pin
52368-S23	No. 8-15 x 7/8" Cross recessed oval head self tapping screw	73232-S	1/8" x 1/2" Dowel pin
52376-S13	No. 8-15 x 1" Cross recessed oval head self tapping screw	73259-S	3/8" x 5/8" Dowel pin
52382-S13	No. 8-15 x 1-1/4" Cross recessed oval head self tapping screw	73757-S	5/32" x 1-1/4" Taper pin
52720-S8	No. 8-15 x 3/8" Cross recessed pan head self tapping screw	73861-S	5/16" x 5/8" Clevis pin
52721-S8	No. 10-12 x 3/8" Cross recessed pan head self tapping screw	73877-S	1/4" x 25/32" Clevis pin
52727-S8	No. 10-12 x 1/2" Cross recessed pan head self tapping screw	73880-S8	5/16" x 13/16" Clevis pin
52729-S8	No. 14-10 x 1/2" Cross recessed pan head self tapping screw	73896-S7	5/16" x 15/16" Clevis pin
52759-S8	No. 10-12 x 1-1/4" Cross recessed pan head self tapping screw	73911-S7	5/16" x 1-1/16" Clevis pin
60444-S	5/16" x 7/8" Round head solid rivet	74117-S	1" Expansion plug
61489-S	1/8" x 13/16" Button head solid rivet	74121-S	1-1/4" Expansion plug
63375-S10	1/8" x 19/32" Oval head tubular rivet	74153-S	1/4" x 1" Woodruff key
63427-S	3/16" x 1" Oval head tubular rivet	74172-S	No. 3 (1/2" x 1/8") Woodruff key
63527-S	1/8" x 3/16" Oval head tubular rivet	74175-S	5/32" x 5/8" Woodruff key
		74202-S	13/64" Button plug
		74246-S8	15/16" Button plug
		87381-S	1/4"-24 x 90° Tube fitting-elbow
		87901-S8	1/8"-27 x 3/4" Lub. fitting-straight
		87907-S8	1/4"-28 x 1/2" Lub. fitting-straight
		87971-S	1/8"-27 & 7/16"-24 Connector fitting
		88001-S8	5/16"-18 and 5/16"-24 x 7/8" Stud
		88351-S8	5/16"-18 and 5/16"-24 x 7/8" Stud
		88371-S	5/16"-18 and 5/16"-24 x 1-1/4" Stud
		88380-S	3/8"-24 and 3/8"-18 x 1-3/8" Stud
		88413-S	7/16"-20 and 7/16"-14 x 1-3/4" Stud
		88452-S7	3/8"-24 and 3/8"-16 x 2-1/4" Stud
		88473-S	7/16"-20 and 7/16"-14 x 2-1/2" Stud
		88512-S7	3/8"-24 and 3/8"-16 x 3" Stud
		89735-S18	No. 12-28 x 1/4" Headless set screw
		97011-S7	1/4"-28 x 2" Clevis

# Lincoln and Lincoln Cosmopolitan

## CHASSIS PARTS CATALOGUE

### ★ Numerical List of Special Bolts, Pins, Washers, etc.

PART NUMBER	CLASS	PART NAME	PART NUMBER	CLASS	PART NAME
350002-S8		No. 10-24 x 7/16" Slotted hex. head screw	351038-S8		7/16"-28 (7/64" x 5/8") Special hex. nut
350009-S8		No. 8-32 x 5/16" Socket head set screw	351052-S8		1/2"-20 (3/16" x 3/4") Hex. nut
350018-S2		3/8"-24 x 1" Hex. head bolt	351059-S		1/2"-20 (7/16" x 3/4") Slotted hex. nut
350022-S8B		No. 5-40 x 1/4" Fillister head screw and lockwasher assy	351063-S13		3/8"-24 (3/4" O.D.) Slotted round nut
350032-S		No. 10-32 x 27/32" Special head screw	351070-S13		1/2"-20 (27/32" O.D.) Round knurled nut
350057-S7		No. 10-24 x 7/16" Slotted hex. head screw and lockwasher assy	351075-S		9/16"-18 (3/16" x 3/4") Hex. locknut
350142-S13		No. 10-32 x 1-3/8" Cross recessed oval head machine screw	351112-S		3/8"-24 Hex. compression nut
350177-S		5/16"-24 x 9/16" Serrated shoulder bolt	351124-S		43/64"-20 (17/64" x 15/16") Hex. nut
350189-S7		1/4"-28 x 3/8" Pan head screw and lockwasher assy	351126-S		3/4"-16 (17/64" x 15/16") Hex. nut
350190-S8		No. 10-24 x 1/2" Special round head carriage bolt	351128-S		3/4"-16 (1/4" x 1-1/16") Hex. nut
350209-S2		5/16"-10 x 1/2" Hex. head bolt	351129-S		3/4"-16 (37/64" x 1-1/4") Hex. slotted nut
350212-S7		1/4"-20 x 5/8" Hex. hd bolt & L/W assy	351142-S		3/4"-16 (1/2" x 1-1/4") Special hex. nut
350216-S7		1/4"-20 x 13/16" Hex. hd bolt & L/W assy	351146-S7		3/4"-11 (3/8" x 1") Special hex. nut
350267-S7		5/16"-24 x 5/8" Hex. hd bolt and lockwasher assy	351149-S7		7/8"-11 (7/16" x 1-1/8") Special hex. nut
350321-S2		5/16"-24 x 2-7/8" Special head bolt	351153-S		7/8"-14 (7/16" x 1-7/16") Special hex. nut
350323-S2		5/16"-24 x 2-3/4" Special head bolt	351159-S		7/8"-20 (1/2" x 1-1/4") Hex. slotted nut
350363-S7		1/2" x 1-27/64" Clevis pin	351192-S		9/64" I.D. x 1/4" O.D. x 1/64" Fl. washer
350389-S2		5/16"-18 x 2-5/8" Special head bolt	351230-S7		No. 8 (11/32" x 27/64") Internal washer
350433-S		5/16"-18 x 49/64" Special hex. head shoulder bolt	351249-S7		21/64" I.D. x 11/16" O.D. Spring washer
350479-S2		5/16"-10 x 5/8" Hex-hd Acme thread bolt	351256-S7		3/16" (1/32") Flat washer
350508-S7		3/8"-24 x 3/4" Special hex. head bolt -head drilled	351278-S8		Flat washer
350209-S2		5/16"-10 x 1/2" Hex head bolt	351322-S7		1/4" (1/16" x 45/64") Spring washer
350530-S8B		5/8"-18 x 1-1/16" Shoulder bolt	351331-S7		1/4" I.D. x 11/16" O.D. Flat washer
350583-S2		3/8"-24 x 27/32" Hex. hd shoulder bolt	351341-S7		21/64" I.D. x 5/8" O.D. x 1/64" Spring washer
350604-S		7/16"-20 x 15/16" Hex. head bolt	351359-S7		5/16" I.D. x 1-1/8" O.D. x 9/64" Flat washer
350656-S8		1/2"-20 x 1" Round head carriage bolt	351360-S7		5/16" (1/32" x 3/4") Flat washer
350670-S8		7/16"-20 x 7/8" Hex. head bolt	351377-S7		25/64" (1/32" x 21/32") Flat washer
350721-S8		1/2"-20 x 3-1/4" Hex. head shoulder bolt	351385-S7		25/64" I.D. x 3/4" O.D. x 3/32" Flat washer
350781-S8		7/16"-20 x 4-1/4" Hex. head bolt-pointed	351467-S		3/8" I.D. x 25/32" O.D. x 1/64" Sprg. washer
350786-AS7		1/8" Spring nut-flat type	351473-S7		23/64" (1/64" x 1") Spring washer
350790-S7		9/16"-18 x 1-27/32" Hex. head bolt	351489-S2		13/32" (21/32" x 41/64") Special washer
350791-S		3/8"-24 x 3/4" Hex. head shoulder bolt	351496-S		5/8" (5/64" x 63/64") Lockwasher
350811-S7		7/16"-20 x 1-3/8" Hex. head bolt	351509-S7		5/8" (41/64" x 1-7/64") Lockwasher
350815-S7		1/2"-13 x 2-7/8" Special hex. head bolt	351536-S7		3/4" (3/32" x 1-1/8") Flat washer
350836-AS7		3/16" (3/8" x 5/8") Spring nut-flat type	351538-S7		3/4" (3/32" x 1-3/8") Flat washer
350846-S32		No. 14 Spring nut-"J" shape	351543-S		5/16" (7/16" x 1/32") Flat washer
350849-S7		No. 10-32 Stamped hex. nut	351597-S		1-1/8" I.D. x 1-3/8" O.D. x 1/16" thick Copper gasket
350860-S		No. 10-32 (1/8" x 3/8") Hex. nut	351600-S8		7/32" I.D. x 5/8" O.D. x 1/4" Cup washer
350900-S32		No. 10Z Spring nut-"J" shape	351601-S8		9/32" I.D. x 5/8" O.D. x 1/4" Cup washer
350945-S32		5/16"-10 Spring nut-"J" shape	351629-S28AB		No. 6 x 1/2" Binding head drive nail
350949-S32		5/16"-12 Spring nut-"J" shape	351640-S32		9/32" Spring nut
350983-S		5/8"-18 (21/64" x 15/16") Special hex. nut-thin	351656-S2		5/16"-24 x 3-1/4" Special head bolt
350997-S		5/16"-18 x 9/16" Special hex. head screw	351681-S32		2-23/32" x 2-11/16" O.D. Speed nut for 1-3/4" O.D. Shaft
350999-S		5/16"-18 x 3/4" Special hex. head screw	351700-S		11/32" I.D. x 5/8" O.D. Special washer
351025-S7		7/16"-20 (11/16" x 7/16") Special hex. nut	351704-S32		1-29/32" Clip-electric wiring
			351724-S2		5/16"-10 x 3/4" Hex. head bolt
			351881-S8		1/8" x 5/32" Round head tubular rivet
			352200-S		3/64" x 3/8" Cotter pin
			352301-S8		1/4"-20 x 3/4" Cross recessed pan head screw and lockwasher assy



# Lincoln and Lincoln Cosmopolitan

## CHASSIS PARTS CATALOGUE

### \* Numerical List of Special Bolts, Pins, Washers, etc.—Continued

PART NUMBER	PART NAME	PART NUMBER	PART NAME
352358-S	9/32" x 61/64" Self locking pin	355021-S7	No. 6-32 x 21/64" Screw & lockwasher assy
352380-S13	Button plug-for 3/4" diameter hole	355067-S7	No. 8-32 x 5/16"-Fillister head screw and lockwasher assy
352422-S	15/64" (3/64" x 9/16") Rubber washer		
352423-S	9/16" Rubber bushing	355073-S7	No. 8-32 x 5/16" Pan hd screw & L/W assy
352424-S	Rubber grommet-for 1/2" hole	355083-S13	No. 8-32 x 5/8" Cross recessed oval head machine screw
352425-S	No. 10-32 x 19/64" Hex. tapped eyelet		
352581-S7	5/16" x 1-1/2" Special flat head pin	355114-S7	No. 10-32 x 1/2" Hex. socket hd set screw
352588-S7	5/16" x 1-3/8" Clevis pin	355176-S7	No. 6-32 x 5/32" Fillister head screw
352656-S8	7/16" dia. x 1-3/4" Grooved pin	355237-S	1/4"-20 x 1-1/4" Fillister head screw
352740-S7	9/16"-18 and 9/16"-12 x 2-39/64" Stud	355249-S	No. 12-32 x 1-1/16" Hex. head screw
352755-S8	3/8"-16 and 3/8"-24 x 2-1/16" Stud	355296-S7	1/4"-20 x 1/2" Hex. hd bolt & L/W assy
352771-S	7/16"-20 and 7/16"-14" x 3-11/64" Stud	355301-S2	1/4"-20 x 3/4" Socket head cap screw
352775-S34	1/4"-20 x 1" Stud-full thread	355312-S34	1/4"-28 x 3/8" Headless set screw
352879-S8	No. 10-24 x 5/8" Slotted hex. head screw	355321-S7	1-9/32" Square (1/2"-20 x 5/8") Ret. assy
352882-S8	No. 12-24 x 15/16" Fillister head screw and lockwasher assy	355368-S2	5/16"-18 x 5/8" Hex. hd screw & L/W assy
		355401-S8	5/16"-24 x 7/8" Hex. head shoulder bolt-head drilled
352884-S8	1/4" x 7/16" Flat Washer		
352891-S	5/64" x 9/32" Straight pin	355407-S8	5/16"-18 x 5/8" Hex. head bolt & L/W assy
352892-S8B	No. 10-32 x 1-1/8" Fillister head screw -dog point	355410-S2	5/16"-24 x 3/4" Round head carriage bolt
		355411-S2	5/16"-18 x 3/4" Hex. head bolt and lockwasher assy
352893-S8	1/4" I.D. x 7/16" O.D. x 5/64" Spacer		
352895-S8	1/16" diameter Groove pin	355414-S7	5/16"-18 x 15/16" Hex. head bolt
352896-S	23/64" I.D. x 5/8" O.D. Washer (spacer)	355428-S	1/2" I.D. x 1" O.D. x 17/64" thick Grommet
352897-S	Washer (spacer)-special	355432-S	5/16"-18 x 5-1/2" Hex. head bolt
352960-S	5/32" I.D. x 3/4" O.D. x 7/16" Grommet	355480-S8	5/16"-24 x 7/8" Hex. hd bolt-body drilled
352961-S	7/32" I.D. x 7/8" O.D. x 7/16" Grommet	355482-S	3/8"-24 x 3" Hex. head bolt
352962-S	13/32" I.D. x 7/8" O.D. x 7/16" Grommet	355653-S8	1/2"-20 x 1-7/8" Hex. hd bolt end drilled
352963-S	1/4" I.D. x 3/4" O.D. x 7/16" Grommet	355687-S7	1/2"-20 x 2" Round head carriage bolt
353002-S	9/16" Inverted male connector	355688-S8	1/2"-20 x 1-1/2" Carriage bolt
353023-S7	1/4"-28 x 1/2" x 90° Lubricator fitting	355692-S	1/2"-20 x 1-1/8" Hex. head bolt
353024-AS7	1/8"-27 x 45° Lubricator fitting-check valve type	355753-S	5/16"-24 x 2-3/4" Round head tie bolt
		355765-S	1/2"-13 x 2-1/4" Hex. head bolt
353047-AS7	1/8" Drive lub. fitting check valve type	355768-AS2	No. 10 (17/32" x 7/16") Sprng. nut "U" shape
353051-S	3/4" x 15/16" Sq. extended hd pipe plug	355789-S	5/16"-24 x 2-7/8" Round head tie bolt
353052-S5	1/8" Round headless slotted pipe plug	355811-S	7/16"-20 x 1" Hex. head self locking bolt
353055-S7	1/4"-18 Square extended head pipe plug	355829-S7	No. 8-36 (1/8" x 5/16") Hex. nut
353064-S	1/2" Square extended head pipe plug	355847-S	3/8" Spring nut-flat type
353075-S	3/8" diameter Steel ball	355862-S32	No. 14 Spring nut "J" shape
353079-S	1/2" diameter Steel ball	355875-S32	No. 8 Spring nut "U" shape
353080-S	3/16" diameter Steel ball	355880-S32	No. 14 Spring nut "J" shape
353082-S	7/16" diameter Steel ball	355888-S32	No. 10 Spring nut "U" shape
353245-S	1/2"-20 Inverted elbow	355914-S32	No. 10-3/8" x 5/8" Spring nut-flat
353247-SA	13/64" x 13/32" Rubber grommet	355993-S8	3/8"-24 (5/32" x 9/16") Hex. locknut
353261-S7	7/32" Hole (5/8" x 1-1/16") Clip "J" shape	356006-S2	3/8"-24 Nut retainer
		356021-S	7/16"-20 (3/8" x 5/8") Hex. nut
353262-S	9/32" Hole (5/8" x 1-29/32") Clip "J" shape	356023-S13	7/16"-28 Special nut
		356060-S32	5/16"-10 (1" x 63/64") Sprng. nut-"U" shape
353266-AS	9/32" Hole (5/8" x 2") Clip "J" shape	356062-S8	7/16"-20 (7/16" x 11/16") Hex. nut
353298-S	13/64" (1/2" x 45/64") Cable clip	356080-S32	1/2"-20 Spring nut
353361-S	7/16" (1" x 1-1/2") Cable clip	356094-S13	5/8"-24 (3/16 x 3/4") Octogan nut
353363-S32A	5/16"-10 Spring nut-"J" shape	356115-S32	No. 14 (3/4" x 41/64") Sprng. nut-"J" shape
353366-S32	No. 10A Spring nut-"U" shape	356208-S	1/4" I.D. x 31/32" O.D. x 1/16" Fl. washer
353367-S	5/16" diameter (49/64" x 2-21/32") Cable clip	356210-S8	1/4" (3/64" x 9/16") Flat washer
		356216-S7	17/64" (3/4" x 1/16") Flat rubber washer

# Lincoln and Lincoln Cosmopolitan

## CHASSIS PARTS CATALOGUE

### \*Numerical List of Special Bolts, Pins, Washers, etc.—Continued

PART NUMBER	PART NAME	PART NUMBER	PART NAME
356288-S8	21/64" I.D. x 11/16" O.D. x 3/16"-Spacer	357257-S2	5/16"-24 Nut and retainer assy
356306-S7	5/16" I.D. x 1-1/8" O.D. x 3/32" thick Special serrated washer	357295-S8	1/2"-20 x 1-3/4" Flat head screw
356326-S7	3/8" (25/64" x 1-1/8") Flat washer	357324-S8	No. 8-36 x 11/64" Set screw
356329-S	21/64" (1" x 1-15/64") Rectangular washer	357479-S15	3/16" x 1" Roll pin
356335-S	15/64" (3/64" x 15/32") Lockwasher	357518-S	1/2"-14 x 1/2"-27 Connector fitting
356360-S8	11/32" I.D. x 5/8" O.D. x 5/32" Special washer	357614-S8	5/32" x 3/8" Grooved pin
356381-S7	27/64" I.D. x 13/16" O.D. x 3/32" Fl. washer	357776-S8	1/4" deep x 53/64" I.D. x 7/32" hole cup washer
356383-S7	7/16" Spring washer-three wave	357798-S8	5/16"-12 x 7/8" Hex-hd bolt & L/W assy
356385-S7	27/64" I.D. x 1-1/32" O.D. x 5/64" Special cup washer	357814-S	Rubber bumper
356409-S8	3/8" (1/16" x 3/4") Flat washer	357848-S	No. 8-15 x 7/8" Screw cross recessed oval head
356434-S7	53/64" I.D. x 1-1/16" O.D. x 5/64" Fl. washer	357900-S8	3/8"-24 Hex. nut
356474-S	1/2" I.D. x 1" O.D. x 7/64" Flat washer	357901-S8	3/8"-24 x 1-3/16" Hex. head bolt
356504-S	25/32" (1-1/2" x 1/8") Flat washer	357908-S	Rubber Grommet
356586-S2	7/8" (3/64" x 1-5/16") Internal tooth L/W	357979-S	1/2"-20 x 90° Inerted male elbow
356595-S	Locking plate-rad.support-3" bolt centers	357980-S	7/16"-24 Compression nut
356597-S	Locking plate-1.820" bolt centers	357985-S	1/2" Standard hex. head pipe plug
356607-S2	3/8" Lockwasher	358003-S	1/4" hose size 1/8"-27 male thread adaptor fitting
356618-S	5/32" I.D. x 17/32" O.D. Flat washer	358034-S	1/4"-18 Headless slotted pipe plug
356619-S	1/8" I.D. x 17/32" O.D. x 1/32" Fl. washer	358048-S	3/4"-14 Square socket head pipe plug
356620-S	1/8" (17/32" x 1/16") Flat washer	358050-S	1/2" Expansion plug 1/16" hole drilled through center
356628-S	13/32" (5/8" x 1-3/4") Clip-"J" shape	358058-S8	1/8"-27 Hex. head pipe plug
356632-S	7/32" I.D. Rubber grommet	358066-S8	3/8"-18 Hex. head pipe plug
356640-S2	21/64" Hole (9/16" x 1-3/8") Clip "J" type	358097-S	1-3/8" Expansion plug
356658-S	1" diameter Woodruff key	358099-S	1-3/4" Expansion plug
356687-S32	9/32" x 7/16" x 13/16" Special clip	358122-S21	Clip-overdrive wiring to floor pan
356700-S	5/16"-24 x 3-3/4" Bolt-special	358162-S32	11/32" Hole (7/8" x 2-7/16") Clip "J" type
356816-S	3/8" (17/32" x 1/2") Rubber button plug	358132-S	35/64" Expansion plug-cupped type
357033-S32	No. 10A-1/2" x 9/16" x 3/64" Spring nut "J" shape	358238-S	1/4" male pipe thread and 7/16"-24 connector
357046-S32	No. 14 (9/16" x 25/32") Sprng.nut "J" shape	358248-S	1/2"-20 Hex. compression nut
357206-S34	No. 14-10 x 1/2" x 3/4" Hex washer head self tapping screw	358292-S	Rubber grommet-for 3/8" diameter hole
357225-S8	1/4"-20 x 1/2" Hex.hd screw and L/W assy	358297-S32	Clip
357227-S	1/4"-20 Nut and retainer assy	358313-S32	3/8"-16 Clip
357228-S	15/64" x 1-7/16" Pin	358315-S32	11/16" x 1-1/4" Special clip
357252-S2	5/16"-24 Nut and retainer assy	358340-S	1/4" dia. (5/8" x 15/16") Clip
357253-S2	1/4"-28 Nut and retainer assy	358349-S32	3/16" dia (3/4" x 1-27/32") Clip
357254-S2	1/4"-28 Nut and retainer assy	358360-S	21/64" dia. (5/8" x 1-21/64") Clip
357256-S2	5/16"-24 Nut and retainer assy		

# Lincoln and Lincoln Cosmopolitan

## CHASSIS PARTS CATALOGUE

### Accessories

#### Back Up Lamp

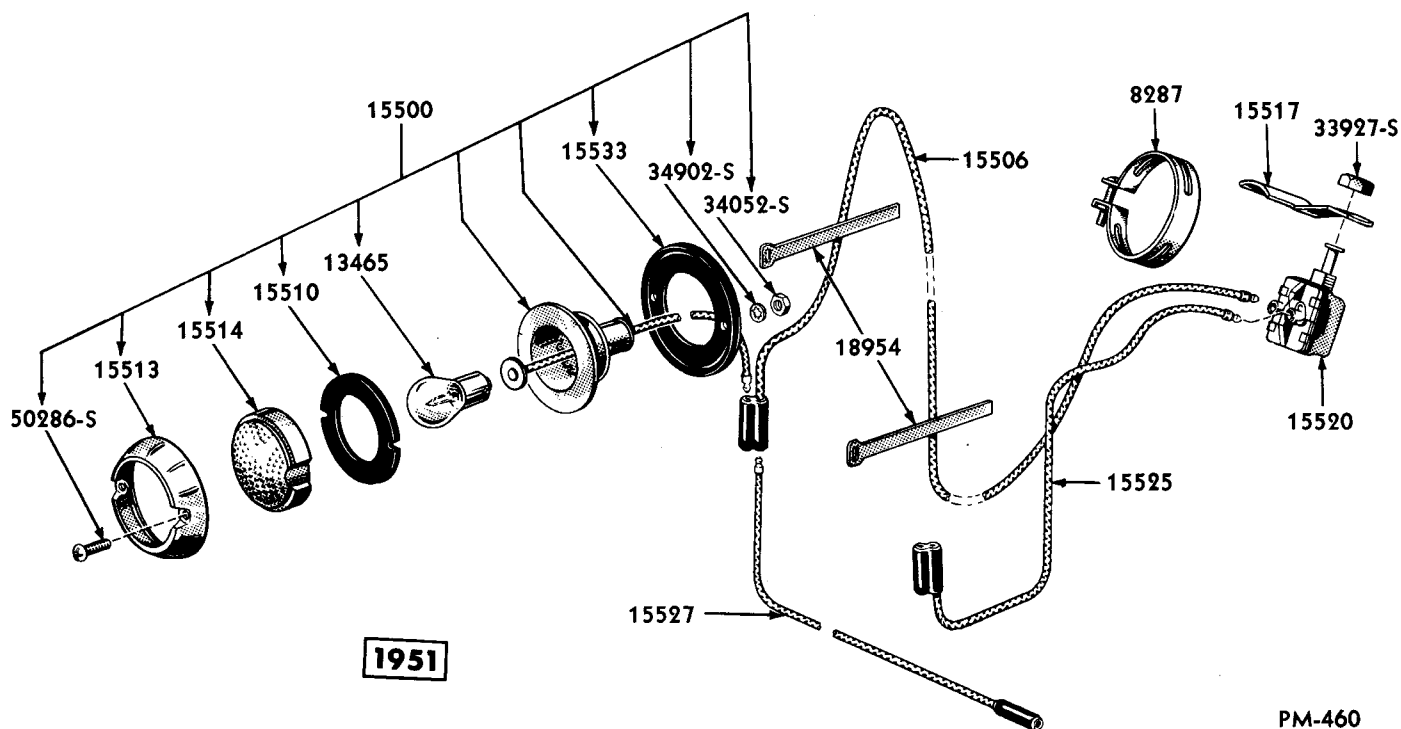

PM-460

#### BACK UP LAMP AND RELATED PARTS

Basic numbers only shown on illustration. Order by Part Numbers shown in list of parts.

PART NUMBER	UNIT	PART NAME	NO. REQ'D	MODEL	YEAR 19__
LH 18274-A		Kit (back up lamp installation)-consists of the following (1) 78-8287-A Clamp (2) OH-15500-B Lamp (1) LH-15506-A Wire (1) 8L-15517 Bracket (1) LH-15520-A Switch (1) LH-15525-A Wire (1) OH-15527-B Wire (2) 8M-18954 Clamp (1) 33927-S7 Nut (4) 34902-S8 Washer	1	1L,1H	51
78 8287-A	NS	Clamp assy (back up lamp)-serviced in LH-18274-A Kit	1	9L,9H,OL,OH,LL,1H	49-51
B 13465		Bulb (back up lamp)-21 C.P.-S.C.	1	9L,9H,OL,OH,LL,1H	49-51
B 14586		Clip (back up lamp wire)	2	9L,9H,OL,OH	49-50
OH 15500-B		Lamp assy (back up)	2	OL,OH,LL,1H	50-51
		34902-S8 Lockwasher (internal tooth)- No. 8-lamp to luggage compt. door	4	OL,OH,LL,1H	50-51
		34908-S2 Lockwasher (internal tooth)- 7/16"-lamp to luggage compt. door	2	9L,9H,OL,OH	49-50
		33802-S2 Nut (hex)-7/16"-20-lamp to luggage compt. door	2	9L,9H,OL,OH	49-50
		34052-S7 Nut (hex)-No. 8-32-lamp to luggage compt. door	4	OL,OH,LL,1H	50-51

# Lincoln and Lincoln Cosmopolitan

## CHASSIS PARTS CATALOGUE

PART NUMBER	PART NAME	NO. REQ'D	MODEL	YEAR
-------------	-----------	-----------	-------	------

### Accessories—Continued

#### Back Up Lamp—Continued

	50286-S13 Screw (cross recess round head)-No. 8-32 x 3/4"-lamp to luggage compt. door	4	OL,OH,1L,1H	50-51
OH 15506	Wire (back up lamp switch to lamp)-170" long	1	OL,OH	50
1H 15506-A	Wire assy (back up lamp switch to lamp)-265" long	1	1L,1H	51
OH 15510	Gasket (back up lamp)-1-13/32" I.D. x 2-3/32" O.D.	2	OL,OH,1L,1H	50-51
8H 15513	Door (back up lamp)-3-1/2" dia.	2	9L,9H	49
OH 15513-A	Door (back up lamp)-2-13/32" dia.-10 serrations	2	OL,OH,1L,1H	50-51
OH 15513-B	Door (back up lamp)-3-1/2" dia-24 serrations	2	OL,OH	50
	30027-S13 Screw (oval head)-No. 6-32 x 5/8"-door to lamp body	2	9L,9H,OL,OH	49-50
8H 15514	Lens (back up lamp)-3-3/16" dia.	2	9L,9H,OL,OH	49-50
OH 15514	Lens (back up lamp)-1-57/64" dia.	2	OL,OH,1L,1H	50-51
8L 15517	Bracket (back up lamp switch mounting)	1	9L,9H,OL,OH,1L,1H	49-51
51A 15520-A	Switch assy (back up lamp)	1	9L,9H,OH,OL	49-50
1H 15520-A	Switch assy (back up lamp)	1	1L,1H	51
	33927-S7 Nut (hex check)-7/16"-20-switch to bracket	1	9L,9H,OL,OH,1L,1H	49-51
OH 15522	Retainer (back up lamp lens)	6	OL,OH	50
8L 15523	Washer (back up lamp mounting)-extended type	1	9L,9H,OL,OH	49-50
8L 15525	Wire assembly (back up lamp)-30" long	1	9L,9H,OL,OH	49-50
1H 15525-A	Wire assy (back up lamp switch to rear lamp feed)-35" long	1	1L,1H	51
OH 15527-B	Wire (back up lamp)-L.H. to R.H.-53" long	1	OL,OH,1L,1H	50-51
NS	8M-18954 Clamp (back up lamp wiring)-use 8L-18954 for service	2	1L,1H	51
8H 15529-B	Spacer (back up lamp mounting)-female	1	9L,9H,OL,OH	49-50
OH 15533	Pad (back up lamp)-1-1/2" I.D. x 2-1/2" O.D.	2	OL,OH,1L,1H	50-51

#### Curb Buffer

LBK 18243-A	Kit (curb buffer moulding installation)-consists of the following (1) OL-16210 Moulding (1) OL-16211 Moulding (1) 1L-7210176 Moulding (1) 1L-7210177 Moulding (14) OL-7210198 Retainer (6) 350190-S8 Bolt (6) 355807-AS7 Nut	1	1L	51
OL 16210	Moulding (front fender lower edge curb buffer)-RH	1	OL,1L	50-51
OL 16211	Moulding (front fender lower edge curb buffer)-LH	1	OL,1L	50-51
1L 7210176	Moulding (body rocker panel curb buffer)-RH	1	1L	51
1L 7210177	Moulding (body rocker panel curb buffer)-LH	1	1L	51
OL 7210198	Retainer (body rocker panel curb buffer moulding)	14	OL,1L	50-51
	350190-S8 Bolt (carriage)-No. 10-24 x 1/2"	6	OL,1L	50-51
	355807-A-S7 Nut (hex washer head stamped)-No. 10-24	6	OL,1L	50-51

# Lincoln and Lincoln Cosmopolitan

## CHASSIS PARTS CATALOGUE

PART NUMBER	PART NAME	NO. REQ'D	MODEL	YEAR
-------------	-----------	-----------	-------	------

### Accessories—Continued

#### Engine Compartment Lamp

8H 18375-A	Kit (engine compartment lamp installation)-consists of the following (1) 8M-15702-A Lamp (5) 8L-18954 Clamp (2) 34803-S7 Lockwasher (2) 40542-S8 Screw	1	9L,9H,OL,OH,LL,1H	49-51
8M 15702-A	Lamp (engine compartment)-serviced in 8H-18375-A Kit	1	9L,9H,OL,OH,LL,1H	49-51
	34803-S7 Lockwasher-No. 10	1	9L,9H,OL,OH,LL,1H	49-51
	40542-S8 Screw (pan head self tapping)- No. 10-32 x 5/8"	1	9L,9H,OL,OH,LL,1H	49-51
8L 18954	Clamp (engine compartment wire)	5	9L,9H,OL,OH,LL,1H	49-51

#### Exhaust Deflector

OL 18259	Deflector assy (exhaust)	1	9L,9H,OL,OH,LL,1H	49-51
HAK 18259-A	Kit (exhaust deflector)-consists of the following (1) 1H-18259-C Deflector (Light Blue) (1) 1H-18259-D Deflector (Chrome) (1) 1H-18259-E Deflector (Black) (1) 1H-18259-F Deflector (Light Gray) (1) 1H-18259-G Deflector (Tan)	as req'd	9L,9H,OL,OH,LL,1H	49-51
1H 18259-C	Deflector assy (exhaust)-Light Blue serviced in HAK-18259-A Kit	1	9L,9H,OL,OH,LL,1H	49-51
1H 18259-D	Deflector assy (exhaust)-Chrome-serviced in HAK-18259-A Kit	1	9L,9H,OL,OH,LL,1H	49-51
1H 18259-E	Deflector assy (exhaust)-Black-serviced in HAK-18259-A Kit	1	9L,9H,OL,OH,LL,1H	49-51
1H 18259-F	Deflector assy (exhaust)-Light Gray-serviced in HAK-18259-A Kit	1	9L,9H,OL,OH,LL,1H	49-51
1H 18259-G	Deflector assy (exhaust)-Tan-serviced in HAK 18259-A Kit	1	9L,9H,OL,OH,LL,1H	49-51

#### Fuel Tank Filler Neck Opening Guard

1M 18296	Guard (fuel tank filler neck opening)	1	1L	51
----------	---------------------------------------	---	----	----

#### Gas Filler Lid Lock

8H 18168-C	Kit (gas filler lid lock installation)	1	9H,OH	49-50
1L 18168	Kit (gas filler lid lock installation)	1	1L,1H	51

#### Hand Brake Signal

OH 18159	Kit (hand brake signal lamp installation)-consists of the following (1) 78-13466 Bulb (1) OH-15853 Bracket (1) OH-15855 Flasher (1) 8M-15856 Lens	1	9L,9H,OL,OH,LL,1H	49-51
78 13466	Bulb (hand brake signal)-2 C.P.-S.C.	1	9L,9H,OL,OH,LL,1H	49-51

# Lincoln and Lincoln Cosmopolitan

## CHASSIS PARTS CATALOGUE

PART NUMBER	PART NAME	NO. REQ'D	MODEL	YEAR
-------------	-----------	-----------	-------	------

### Accessories—Continued

#### Hand Brake Signal—Continued

8M 15852	Switch assy (hand brake signal)	1	9L,9H	49
8M 15853	Bracket assembly (hand brake signal lamp)	1	9L,9H	49
OH 15853	Bracket assy (hand brake signal lamp)	1	OL,OH,1L,1H	50-51
	358297-S2 Clip (hand brake signal wire to hand brake bracket)	1	9L,9H	49
	34804-S8 Lockwasher-No. 12	1	OL,OH,1L,1H	50-51
	34054-S8 Nut (hex)-No. 12-24	1	OL,OH,1L,1H	50-51
	26514-S2 Screw (round head)-No. 12-24 x 3/4"	1	OL,OH,1L,1H	50-51
OH 15855	Flasher and sleeve assy (hand brake signal lamp)	1	9L,9H,OL,OH,1L,1H	49-51
8M 15856	Lens assy (hand brake signal lamp)	1	9L,9H,OL,OH,1L,1H	49-51

#### Hot Water Heater

8H 18455-D	NS	Heater assy (hot water)-complete	1	9H	49
8L 18455-D	NS	Heater assy (hot water)-complete	1	9L	49
OH 18455-B	NS	Heater (fresh air hot water)-complete	1	OH	50
1H 18455-A	NS	Heater (fresh air hot water)-complete	1	1H	51
OL 18455-B	NS	Heater (fresh air hot water)-complete	1	OL	50
1L 18455-A	NS	Heater (fresh air hot water)-complete	1	1L	51
		OH-14566-B Support (air control cable)-when heater is removed	1	OH,1H	50-51
		8M-7001846 Plate (heater opening cover)-when heater is not used	1	9L	49
		8A-7001880 Gasket (vent air valve)-when heater is removed	1	OL,1L	50-51
		OM-7201846 Plate (heater opening cover)-when heater is removed	1	OL,1H	50-51
		OH-7301846 Plate (heater opening cover)-when heater is not used	1	OH,1H	50-51
		8H-7301848 Plate (heater control valve opening cover)	1	9L,9H,OL,OH,1L,1H	49-51
		34904-S2 Lockwasher (internal tooth)-No. 12	4	OH,1H	50-51
		74202-S Plug (button)-13/64" diameter-used in dash panel when heater is removed	1	9L,9H	49
		74246-S8 Plug (button)-15/16" diameter-used in dash panel when heater is removed	2	9L	49
		356816-S Plug (button)-3/8" diameter-Rubber-used in dash panel when heater is removed	4 or 5	9L,9H,OL,OH,1L	49-51
		358066-S8 Plug (water pump and cylinder head)-3/8"-when heater is removed	2	1L,1H	51
		31477-S2 Screw (heater control valve cover)-No. 14-10 x 1/2"-when heater is removed	1	OL,1L	50-51

# Lincoln and Lincoln Cosmopolitan

## CHASSIS PARTS CATALOGUE

PART NUMBER	PART NAME	NO. REQ'D	MODEL	YEAR
-------------	-----------	-----------	-------	------

### Accessories—Continued

#### Hot Water Heater—Continued

	32924-S8	Screw (heater opening and control valve opening plates) -No. 10 x 1/2"-when heater is removed	4	1H	51
	52721-S8	Screw (cross recess pan head self tapping)-No. 10-12 x 3/8"-heater duct assy to dash	3	OH,1H	50-51
8H 18456-A		Blower assy (heater)-with two wires from motor	1	9H	49
8H 18456-B		Blower assy (heater)-with two wires from motor	1	OH	50
OH 18456-A		Blower assy (heater)-with three wires from motor	1	OH,1H	50-51
8L 18456-A		Blower and adapter assy (heater)	1	9L	49
OM 18456-B		Blower assy (heater)-complete	1	OL,1L	50-51
	34905-S7	Lockwasher (internal tooth)-1/4"	3	OH,1H	50-51
	33795-S7	Nut (hex)-1/4"-20-blower assy to fender apron	3	OH,1H	50-51
8M 18471-A		Plenum chamber assy (heater)	1	9L,9H	49
	32916-S8	Screw (pan head self tapping)-No. 8-15 x 3/8"-chamber to heater	3	9L,9H	49
OH 18471-A		Plenum chamber assy (heater)	1	OH	50
OH 18471-B		Plenum chamber assy (heater)	1	OH,1H	50-51
OM 18471-A		Plenum chamber assy (heater)	1	OL,1L	50-51
	52720-S8	Screw (cross recessed pan head self tapping)-No. 8-15 x 3/8"	2	OL,1L	50-51
	52721-S8	Screw (pan head)-No. 10-12 x 3/8"-attach control wire clip to plenum chamber assy	1	OH,1H	50-51
	52721-S8	Screw (pan head)-No. 10-12 x 3/8"-chamber to end	2	OH,1H	50-51
	52727-S8	Screw (pan head)-No. 10-12 x 1/2"-plenum chamber to dash	1	OL,1L	50-51
	356360-S8	Washer-11/32" I.D. x 5/8" O.D. x 5/32" thick	4	9H	49
8H 18472-A	NS	Hose (heater inlet)-17-1/2" long-make from 8M-18472-D	1	9H	49
8H 18472-B	NS	Hose (heater return)-37" long-make from 8M-18472-D	1	9H	49
8H 18472-C	NS	Hose (heater temperature control)-19-1/2" long-make from 8M-18472-D	1	9H	49
8L 18472-A	NS	Hose (heater inlet)-21" long-make from 8M-18472-D	1	9L	49
8M 18472-D		Hose (heater)-9/16" I.D. x 1" O.D. x 100' long	as reqd	9L,9H,OL,OH	49-50
1A 18472-A	NS	Hose (heater temperature control)-18" long-make from 1M-18472-C	1	9L,OL,1L	49-51
1A 18472-B	NS	Hose (heater outlet)-39" long-make from 1M-18472-C	1	OH,1H	50-51
1M 18472-B	NS	Hose (heater return)-30" long-make from 1M-18472-C	1	9L,OL,1L	49-51
1M 18472-C		Hose (heater)-5/8" I.D. x 15/16" O.D. x 100' long	as reqd	9L,9H,OL,OH,1L,1H	49-51
OL 18475-A		Plate (heater control name)	1	OL,OH	50
OL 18475-B		Plate (heater control name)	1	OL,OH,1L,1H	50-51

# Lincoln and Lincoln Cosmopolitan

CHASSIS PARTS CATALOGUE

Accessories — Continued

Hot Water Heater—Continued

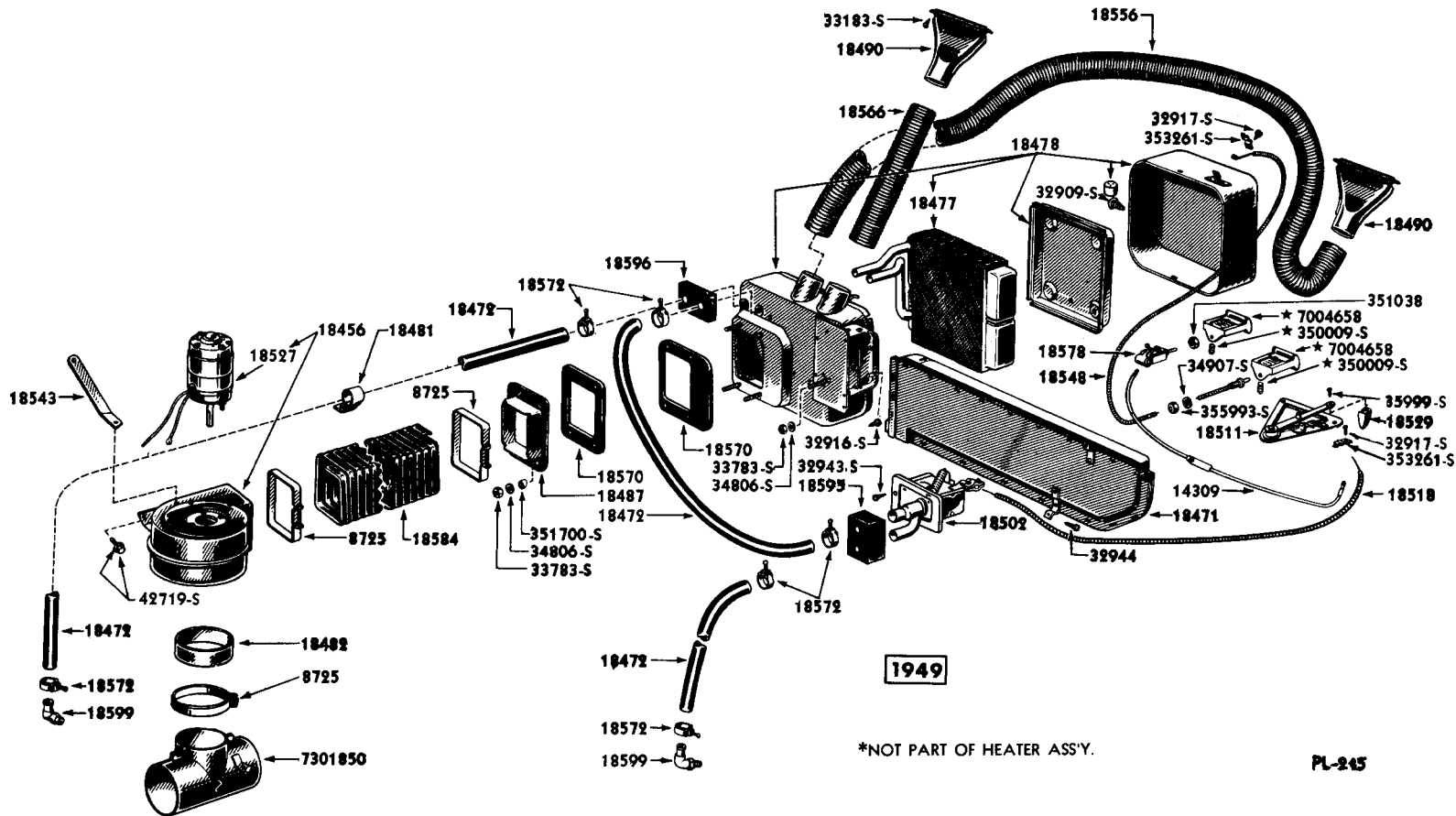

## LINCOLN COSMOPOLITAN HEATER AND RELATED PARTS

Basic numbers only shown on illustration. Order by Part Numbers shown in list of parts.



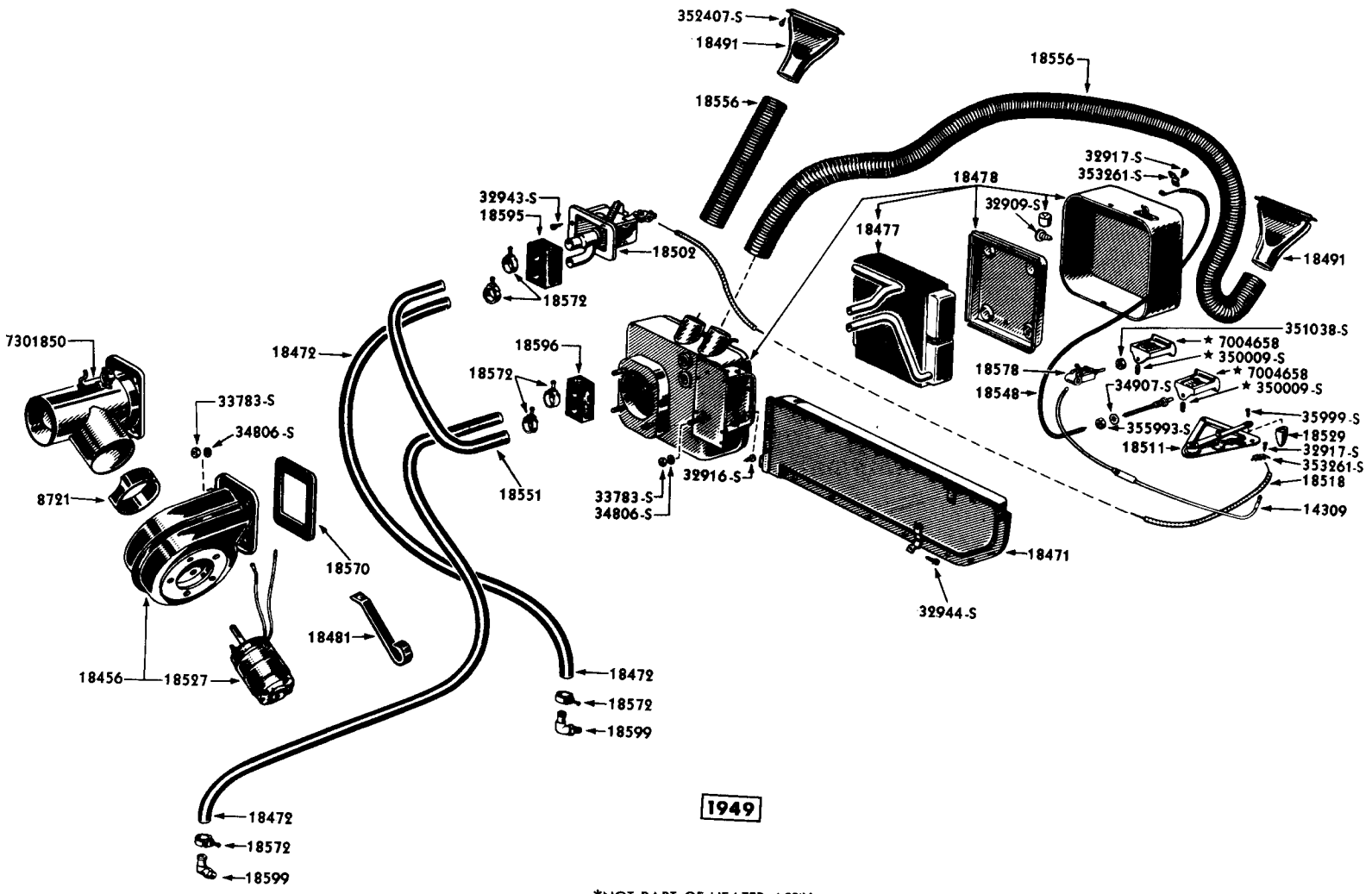

PL-260

**LINCOLN HEATER AND RELATED PARTS**

Basic numbers only shown on illustration. Order by Part Numbers shown in list of parts.

*Lincoln and Lincoln Cosmopolitan*  
CHASSIS PARTS CATALOGUE  
Accessories—Continued

Hot Water Heater—Continued

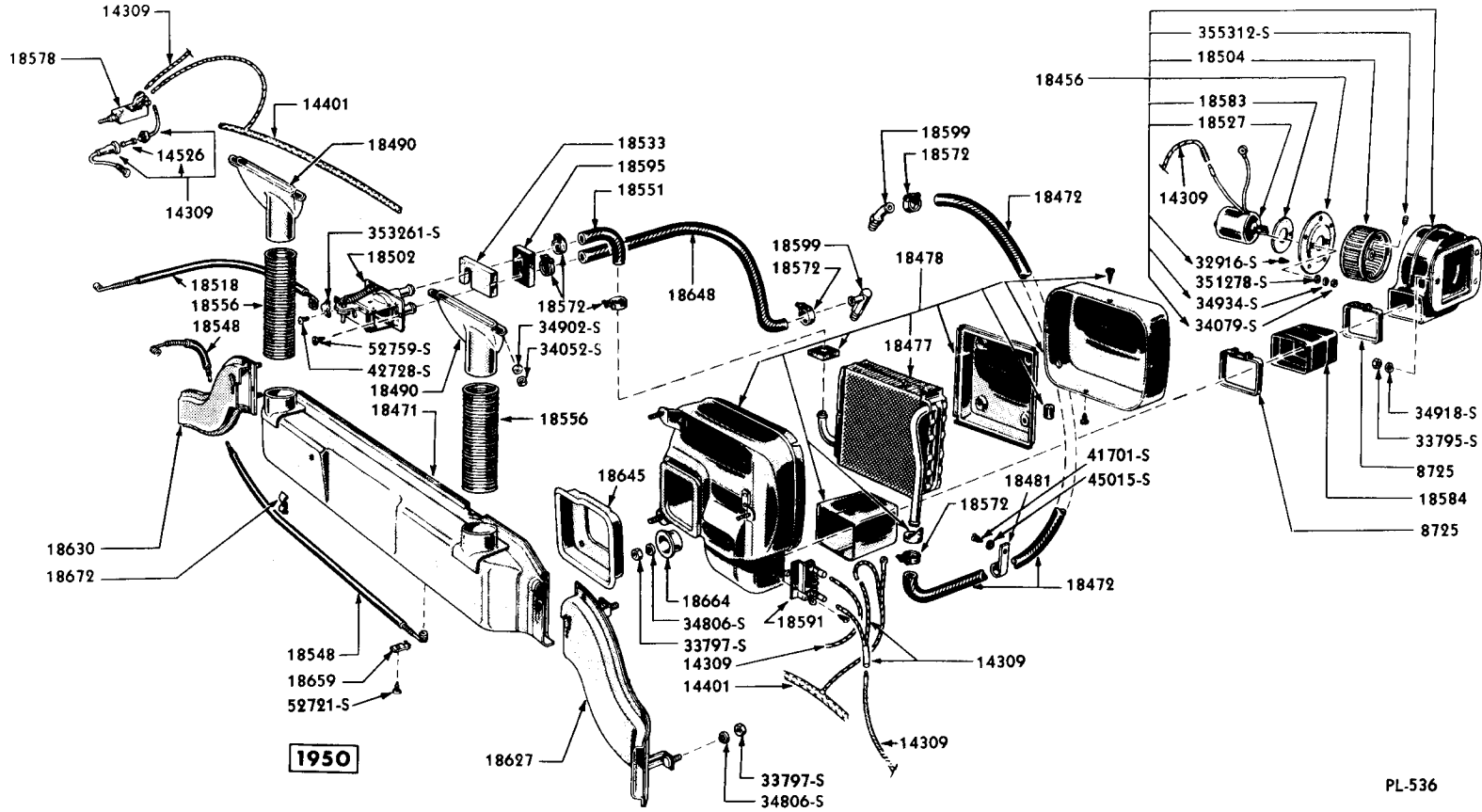

**LINCOLN COSMOPOLITAN HEATER AND RELATED PARTS**

Basic numbers only shown on illustration. Order by Part Numbers shown in list of parts.



# Lincoln and Lincoln Cosmopolitan

## CHASSIS PARTS CATALOGUE

### Accessories—Continued

### Hot Water Heater—Continued

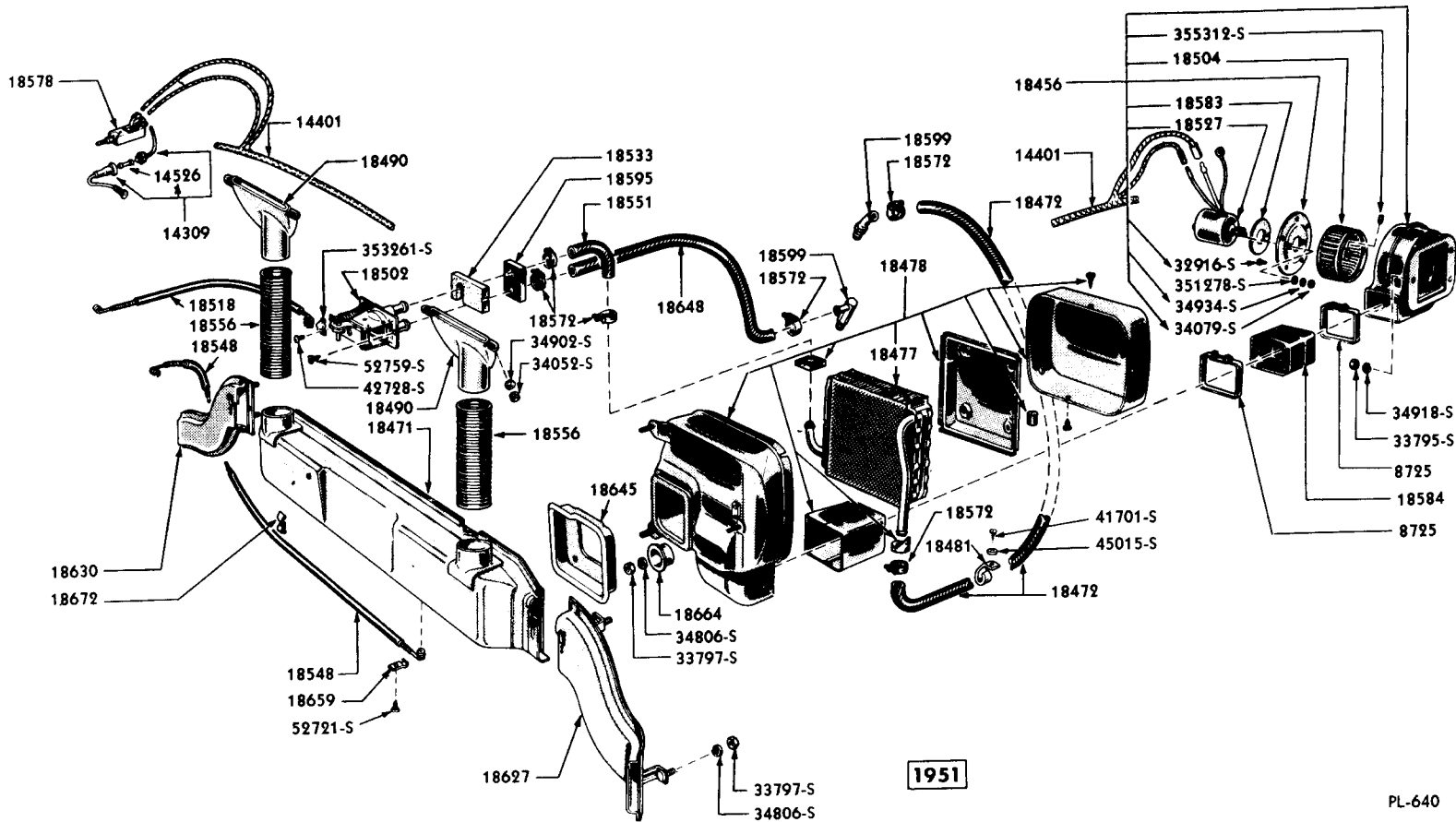

PL-640

## LINCOLN COSMOPOLITAN HEATER AND RELATED PARTS

Basic numbers only shown on illustration. Order by Part Numbers shown in list of parts.

Hot Water Heater—Continued

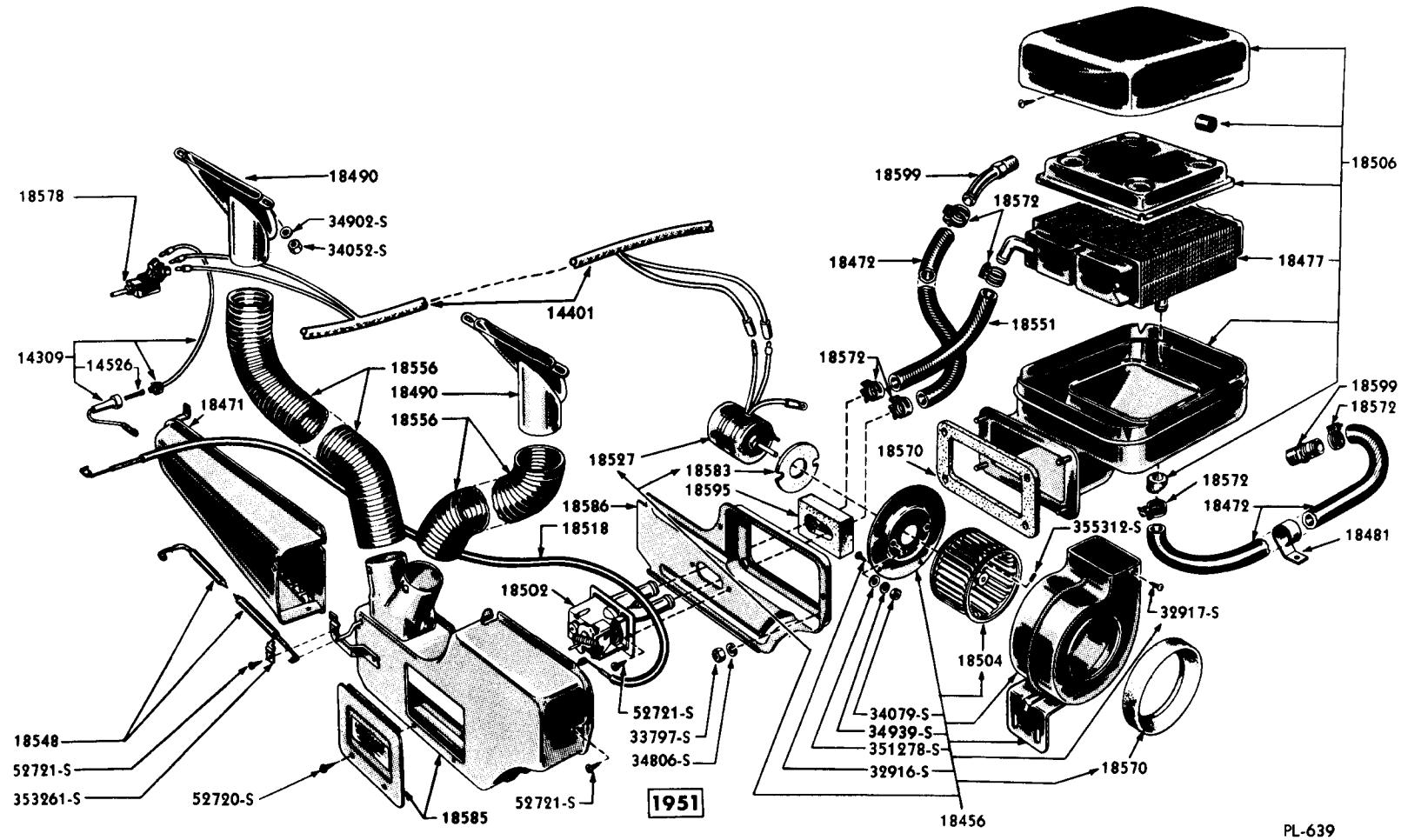

**LINCOLN HEATER AND RELATED PARTS**

Basic numbers only shown on illustration. Order by Part Numbers shown in list of parts.

# Lincoln and Lincoln Cosmopolitan

## CHASSIS PARTS CATALOGUE

PART NUMBER	PART NAME	NO. REQ'D	MODEL	YEAR
<b>Accessories—Continued</b>				
<b>Hot Water Heater—Continued</b>				
8H 18477-A	Core assy (heater)	1	9H	49
8M 18477-A	Core assy (heater)	1	9L	49
OH 18477	Core assy (heater)	1	OH, 1H	50-51
OM 18477	Core assy (heater)	1	OL, 1L	50-51
8H 18478-A	Heater assy (fresh air hot water)-less blower	1	9H	49
8M 18478-A	Heater assy (fresh air hot water)-less blower	1	9L	49
OH 18478	Heater assy (fresh air hot water)-less blower	1	OH, 1H	50-51
OM 18478-B	Heater assy (fresh air hot water)-less blower	1	OL, 1L	50-51
	34806-S7 Lockwasher-5/16"	5	9L, 9H, OL, OH, 1L, 1H	49-51
	33797-S7 Nut (hex)-5/16"-18-heater to dash	5	9L, 9H, OL, OH, 1L, 1H	49-51
	32909-S2 Screw (pan head self tapping)-No. 8-15 x 1/4"	5	9L, 9H, OL, OH, 1L, 1H	49-51
7RA 18481	Bracket (heater hose support)	1	OH	50
8C 18481-A	Bracket (heater hose support)	1	OL, OH	50
8F 18481	Bracket (heater hose support)	1	9H	49
8L 18481	Bracket (heater hose support)	1	9L, OL	49-50
1L 18481	Bracket (heater hose support)	1	1L, 1H	51
	45015-S8 Nut (spring)-No. 10-12	1	OL, OH	50
	45191-S8 Nut (spring)-No. 10-12-bracket to battery tray	1	1L, 1H	51
	41701-S7 Screw (rd-hd)-1/4"-20 x 1/2"	1	OH, 1H	50-51
	52018-S8 Screw (cross recessed flat head self tapping)-No. 10-12 x 1/2"-heater hose bracket to battery tray	1	OL, OH, 1L, 1H	50-51
8H 18482	Seal (heater blower)-3-29/32" I.D. x 1-9/32" wide	1	9H	49
8H 18487	Flange (heater blower duct)	1	9H	49
8H 18490	Nozzle assy (heater defroster)	2	9H	49
*OM 18490	Nozzle assy (heater defroster)-Zinc Die Cast-alternate with 1A-18490-A	2	OL, OH, 1L, 1H	50-51
*1A 18490-A	Nozzle assy (heater defroster)-Painted Steel-alternate with OM-18490	2	OL, OH, 1L, 1H	50-51
	34902-S8 Lockwasher (internal tooth)-No. 8	4	OL, OH, 1L, 1H	50-51
	34052-S7 Nut (hex)-No. 8-32	4	OL, OH, 1L, 1H	50-51
	52720-S8 Screw (cross recessed pan head)-No. 8-15 x 3/8"	4	9H	49
11A 18491-B	Nozzle assy (heater defroster)	2	9L	49
	33444-S2 Screw (pan head self tapping)-No. 10-16 x 1/2"	4	9L	49
1L 18498	Moulding (heater control name plate)	1	1L, 1H	51
8M 18502-B	Valve (automatic temperature regulator)	1	9L, 9H	49
OH 18502	Valve assy (heater automatic temperature regulator)	1	OH, 1H	50-51
OM 18502	Valve assy (heater automatic temperature regulator)	1	OL	50
1M 18502-B	Valve assy (heater automatic temperature regulator)	1	1L	51
	32889-S8 Screw (round head self tapping)-No. 10-12 x 1-1/4"	2	9H	49
	32944-S2 Screw (pan head self tapping)-No. 10-12 x 7/8"	2	9L	49
	52721-S8 Screw (cross recess pan head self tap.)-No. 10-12 x 3/8"	2	OL, 1L	50-51

# Lincoln and Lincoln Cosmopolitan

## CHASSIS PARTS CATALOGUE

PART NUMBER	PART NAME	NO. REQ'D	MODEL	YEAR
-------------	-----------	-----------	-------	------

### Accessories—Continued

#### Hot Water Heater—Continued

	52759-S8	Screw (cross recess pan head self tapping)-No. 10-12 x 1-1/4"	2	OH, LH	50-51
8A 18504		Wheel assy (heater blower)	1	9L, 9H, 0L, 1L	49-51
8C 18504-A		Wheel assy (heater blower)	1	OH, LH	50-51
	355312-S34	Screw (headless socket set)-1/4"-28 x 3/8"	1	9L, 9H, 0L, OH, 1L, 1H	49-51
0M 18506		Housing and core assy (heater)	1	0L, 1L	50-51
8L 18511		Bracket and control assy (automatic temp regulator)	1	9L, 9H	49
	353261-S7	Clip (control wire to bracket)	1	9L, 9H	49
	32917-S7	Screw (pan head self tapping)-No. 10-12 x 3/8"	1	9L, 9H	49
0L 18513		Knob assy (heater blower switch)	1	0L, OH	50
1L 18513		Knob assy (heater blower switch)	1	1L, LH	51
	27153-S7	Screw (round head)-No. 10-32 x 1-1/8"-knob to control housing antenna location	1	0L, OH, 1L, 1H	50-51
	36888-S2	Screw (rd-hd)-No. 10-32 x 7/8"	1	0L, OH, 1L, 1H	50-51
	44713-S8	Washer (flat)-No. 10	2	0L, OH, 1L, 1H	50-51
	351322-S7	Washer (spring)-1/4"-knob to control housing	1	0L, OH, 1L, 1H	50-51
8H 18518-A		Control assy (temperature)-19" long-straight end-used with 8M-18502-A	1	9H	49
8H 18518-B		Control assy (temperature)-20" long-pigtail end-used with 8M-18502-B	1	9H	49
8L 18518-A		Control assy (temperature)-24-1/2" long-straight end-used with 8M-18502-A	1	9L	49
8L 18518-B		Control assy (temperature)-24-1/4" long-pigtail end-used with 8M-18502-B	1	9L	49
OH 18518-B		Control assy (heater temperature)	1	OH, LH	50-51
	16H-16899-A	Clip (temperature control to air regulator control bracket)	1	OH	50
0L 18518-B		Control assy (heater temperature)	1	0L	50
1M 18518-A		Control assy (heater temperature)-46" long	1	1L	51
0L 18519		Knob assy (heater regulator control)	2	0L, OH, 1L, 1H	50-51
	353261-S7	Clip (control wire to heater plate assy)	2	0L, OH, 1L, 1H	50-51
	355993-S8	Locknut-3/8"-24	1	9L, 9H	49
8H 18526		Plug (defroster opening end)-Rubber	1	9H	49
8L 18527		Motor assy (heater blower)-o/all length of shaft is 1-37/64" long	1	9L, 9H	49
OH 18527-B		Motor assy (heater blower)	1	OH, LH	50-51
OM 18527-B		Motor assy (heater blower)-o/all length of shaft is 1-53/64" long	1	0L, 1L	50-51
8L 18529		Knob (automatic temperature regulator control)	1	9L, 9H	49
	35999-S7	Screw (flat-hd)-No. 8-32 x 1/2"	1	9L, 9H	49
8H 18543		Bracket (heater blower)	1	9H	49

# Lincoln and Lincoln Cosmopolitan

## CHASSIS PARTS CATALOGUE

PART NUMBER	PART NAME	NO. REQ'D	MODEL	YEAR
-------------	-----------	-----------	-------	------

### Accessories—Continued

#### Hot Water Heater—Continued

8H 18548	Control assy (defroster)-22-1/8" long	1	9H	49
8L 18548	Control assy (defroster)-17-5/8" long	1	9L	49
OH 18548-B	Control assy (heater defroster)	1	OH,1H	50-51
	16H-16899-A Clip (defroster control to air regulator control bracket)	1	OH,1H	50-51
OL 18548-B	Control assy (heater defroster)-26-1/4" length	1	OL,1L	50-51
	8L-7004658-D Tray assy (defroster control)	1	9L,9H	49
	353261-S7 Clip (defroster control wire to heater outlet front plate)	1	OL,OH,1L,1H	50-51
	355993-S Locknut-3/8"-24	1	9L,9H	49
	34907-S7 Lockwasher (internal tooth)-3/8"	1	9L,9H,9L,OH	49-50
	42728-S8 Screw and washer (hex-hd)-No. 10-32 x 1/2"-clip to control bracket	2	OL,OH,1L,1H	50-51
	52721-S8 Screw (pan-hd)-No. 10-12 x 3/8"-clip to heater outlet front plate	1	OL,OH,1L,1H	50-51
	350009-S8 Screw (socket head set)-No. 8-32 x 5/16"	1	9L,9H	49
OL 18549	Control assy (heater temperature regulator)	1	OL,OH	50
	41556-S8 Screw (pan head self tapping)-No. 10-32 x 3/8"	2	OL,OH	50
	42728-S8 Screw and washer (hex-hd)-No. 10-32 x 1/2"-control lever to mounting plate	1	OL,OH,1L,1H	50-51
1A 18551-A	Hose (water regulator to heater)-formed	1	9L	49
OM 18551	Hose (heater temperature valve to heater core)-formed	1	OL,1L	50-51
1H 18551-A	NS Hose (heater temperature valve to heater core)-6" long-make from 1M-18472-C	1	OH,1H	50-51
1M 18551-A	NS Hose (heater temperature valve to heater core)-formed-use OM-18551 for service	1	1L	51
8H 18556-A	Hose (heater defroster)-passenger side-7-1/2" long	1	9H	49
8H 18556-B	Hose (heater defroster)-driver's side-37" long	1	9H	49
8M 18556-A	Hose (heater defroster)-passenger side	1	9L	49
8M 18556-B	Hose (heater defroster)-driver's side	1	9L	49
OH 18556-A	Hose (heater defroster)-8-1/2" long	2	OH,1H	50-51
OL 18556-A	Hose (heater defroster)-11-1/2" long-passenger side	1	OL,1L	50-51
OL 18556-B	Hose (heater defroster)-31-1/2" long-driver's side	1	OL,1L	50-51
8L 18565	Mounting and motor (heater blower)	1	9L,9H,OL,OH	49-50
OH 18565-A	Mounting and motor assy (heater blower)	1	OH,1H	50-51
	358292-S Grommet-1/4" I.D. x 3/8" O.D. x 3/16" thick	2	9L,9H,OL,OH,1L,1H	49-51
	32916-S8 Screw (pan-hd)-No. 8-15 x 3/8"-mounting to blower housing	5	9L,9H,OL,OH,1L,1H	49-51
8H 18570-A	Gasket (heater to dash)-outer	1	9H	49
8H 18570-B	Gasket (heater)-inner	1	9H	49
8M 18570-B	Gasket (blower motor housing to dash)-square hole-1/4" thick.	1	9L	49



# Lincoln and Lincoln Cosmopolitan

## CHASSIS PARTS CATALOGUE

PART NUMBER	PART NAME	NO. REQ'D	MODEL	YEAR
<b>Accessories—Continued</b>				
<b>Hot Water Heater—Continued</b>				
8M 18570-C	Gasket (heater core housing to dash)-round hole-1/4" thick	1	9L	49
OM 18570-A	Gasket (heater core housing to dash)-Rubber-3-7/8" x 6-15/16"	1	OL,LL	50-51
OM 18570-B	Gasket (heater blower housing to valve assy)-Rubber-5-1/4" O.D. x 4" I.D.	1 1	OL,LL OL,LL	50-51 50-51
7RA 18572-A	Clamp (heater hose)	6or8	9L,9H	49
OA 18572-A	Clamp (heater hose)-stamped "OA-A1 or 2"	4or6	OL,OH	50
1C 18572-A	Clamp (heater hose)-stamped "1C-A1 or 2"	6	1L,1H	51
8A 18578-A	Switch assy (heater control)	1	9L,9H	49
OL 18578-B	Switch assy (heater control)	1	OL,OH	50
1H 18578-A	Switch assy (heater control)	1	1L,1H	51
	351038-S8 Nut (hex)-7/16"-28-heater motor switch to instrument panel	1	9L,9H	49
	8L-7004658-E Tray assy (heater switch)	1	9L,9H	49
	350009-S8 Screw (socket head set)-No. 8-32 x 5/16"	1	9L,9H	49
	8L-14309 Jumper wire assy (heater switch to ignition switch)-19" long	1	9L,9H	49
	OH-14309-B Wire assy (heater switch to blower motor)-75-1/4" long	1	OH	50
	OH-14309-C Wire assy (heater switch to resistor)-75" long	1	OH	50
	OH-14309-D Wire assy (heater switch resistor)-6" long	1	OH	50
	OL-14309-A Wire assy (heater switch to blower motor)-60-1/4" long	1	OL	50
	OL-14309-B Wire assy (heater switch to resistor)-39" long	1	OL	50
	OL-14309-C Wire assy (heater switch resistor)-16" long	1	OL	50
	OM-14309-A Wire and fuse assy (ignition switch to heater switch)-8" long	1	OL,OH,1L,1H	50-51
NS	B-14526 Fuse (heater blower motor)-20 amp.-replaced by B-14527 Kit	1	9L,9H,OL,OH,1L,1H	49-51
8M 18583	Gasket (motor mounting to dash)	1	9L	49
8H 18583	Gasket (heater blower motor mounting)-3-3/8" O.D. x 1-1/2" I.D.-Felt	1	OL,OH,1L,1H	50-51
8H 18584-A	Duct (heater)-flexible-10" long	1	9H	49
OH 18584	Duct (heater)-4-5/64" O.D. x 3-31/32" I.D. x 3-1/2" wide-Rubber	2	OH,1H	50-51
	8H-8725 Clamp (air duct retainer)-square-4-1/8" I.D.	2	9H,OH,1H	49-51
OM 18585-B	NS Plate (heater outlet)-front-serviced in heater assy	1	OL,1L	50-51
OM 18586-B	NS Plate (heater outlet)-rear-serviced in heater assy	1	OL,1L	50-51
	52720-S8 Screw (pan-hd)-No. 8-32 x 3/8"-plate to heater outlet plate	2	OL,1L	50-51
	52721-S8 Screw (pan-hd)-No. 10-12 x 3/8"-plate to rear plate	2	OL,1L	50-51

# Lincoln and Lincoln Cosmopolitan

## CHASSIS PARTS CATALOGUE

PART NUMBER	PART NAME	NO. REQ'D	MODEL	YEAR
-------------	-----------	-----------	-------	------

### Accessories—Continued

### Hot Water Heater—Continued

OH 18591	Resistor (heater switch)	1	OL,OH	50
	32914-S8 Screw (pan-hd)-No. 6-18 x 3/8"-resistor to dash	2	OL,OH	50
3M 18595	Gasket (heater temperature regulator)	1	9L,9H	49
OM 18595	Gasket (heater temperature regulator)	1	OL,OH,1L,1H	50-51
8M 18596	Gasket (heater core tubes to dash)	1	9L,9H	49
OL 18598	Bezel (heater blower switch)	1	OL,OH,1L,1H	50-51
	27153-S7 Screw (round head)-No. 10-32 x 1-1/8"-bezel to control housing antenna	1	OL,OH,1L,1H	50-51
	36888-S2 Screw (round head)-No. 10-32 x 7/8"-bezel to control housing blower	1	OL,OH,1L,1H	50-51
	44713-S8 Washer (flat)-No. 10-bezel to control housing	2	OL,OH,1L,1H	50-51
1GA 18599	Elbow (heater connection)-90° angle	1	9H	49
8A 18599	Elbow (heater connection)-45° angle	1 or 2	9L,9H,OL,OH,1L,1H	49-51
OH 18599	Elbow (heater hose connection)-90°	1	OH,1H	50-51
OH 18627-B	End assy (heater plenum chamber)-RH	1	OH,1H	50-51
	34806-S7 Lockwasher-5/16"-end to dash	6	OH,1H	50-51
	33797-S7 Nut (hex)-5/16"-18-end to dash	6	OH,1H	50-51
OH 18630-C	End assy (heater plenum chamber)-LH	1	OH,1H,except 76	50-51
OH 18630-D NS	End assy (heater plenum chamber)-LH-make from OH-18630-C	1	OH76,1H76	50-51
OH 18645	Duct assy (heater to plenum)-air	1	OH,1H	50-51
	52721-S8 Screw (pan-hd)-No. 10-12 x 3/8"-duct to dash	3	OH,1H	50-51
OM 18646	Control assy (air regulator)-LH	1	OL,OH,1L,1H	50-51
	41036-S8 Screw (hex-hd)-No. 10-32 x 3/8"-control to instrument and control housing	2	OL,OH,1L,1H	50-51
OH 18648	Hose (heater inlet)-formed	1	OH	50
1H 18648-A	Hose (heater inlet)-formed	1	1H	51
OM 18651	Screw and lockwasher assy (heater to dash)-1/4"-28 x 1/2"	2	OL,1L	50-51

### License Plate Frames

5EH 18480-A	Frame assy (license)-except California and Wisconsin -square corners	2	9L,9H,OL,OH,1L,1H	49-51
5EH 18480-B	Frame assy (license)-for California and Wisconsin -round corners	2	9L,9H,OL,OH,1L,1H	49-51

# Lincoln and Lincoln Cosmopolitan

## CHASSIS PARTS CATALOGUE

### Accessories—Continued

### Radio

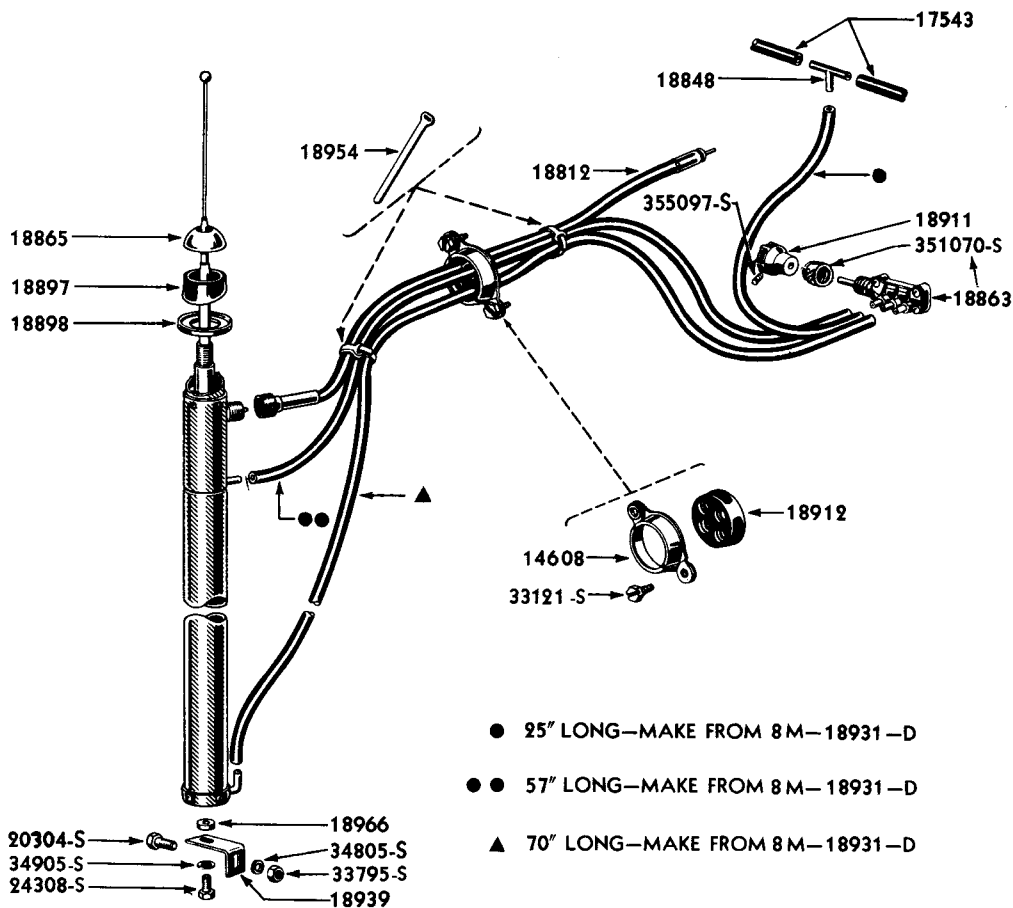

PL-267

### RADIO VACUUM ANTENNA AND RELATED PARTS

Basic numbers only shown on illustration. Order by Part Numbers shown in list of parts.

PART NUMBER	QUANTITY	PART NAME	NO. REQ'D	MODEL	YEAR
1H 18805-A		Radio assy (8 tube)-less antenna	1	1L,1H	51
8H 18812		Lead-in assy (radio antenna)-52" long	1	9H	49
OH 18812		Lead-in assy (radio antenna)-52-1/2" long	1	OH,1H	50-51
8L 18812		Lead-in assy (radio antenna)-34-1/2" long	1	9L	49
OL 18812		Lead-in assy (radio antenna)-41-1/2" long	1	OL,1L	50-51
		OM-14533 Wiring assy (radio pilot lamp jumper)-6" long	1	OL,OH	50
		40631-S8 Screw (round head)-No. 8-32 x 1/4"-lead in to rod and cylinder	2	OL,OH,1L,1H	50-51
8L 18813		Antenna assy (radio)-vacuum	1	9L	49
OH 18813-C		Antenna assy (radio)-vacuum	1	OH	50
OL 18813		Antenna assy (radio)-vacuum	1	OL	50
1H 18813		Antenna assy (radio)-vacuum	1	1H	51
1L 18813		Antenna assy (radio)-vacuum	1	1L	51

# Lincoln and Lincoln Cosmopolitan

## CHASSIS PARTS CATALOGUE

PART NUMBER	CLASS	PART NAME	NO. REQ'D	MODEL	YEAR
-------------	-------	-----------	-----------	-------	------

### Accessories—Continued

#### Radio—Continued

		20252-S2 Bolt (hex-hd)-1/2"-13 x 2-3/4"	1	9L,9H,OL,OH,1L,1H	49-51
		34905-S7 Lockwasher-1/4"	1	9L,9H,OH,1H	49-51
		34805-S8 Lockwasher-1/4"	1	OL,1L	50-51
		33795-S7 Nut (hex)-1/4"-20	1	9L,9H,OL,OH,1L,1H	49-51
		351070-S13 Nut (round knurled)-1/2"-20	1	9L,9H,OL,OH,1L,1H	49-51
		353167-S13 Plug (button)-9/16"	1	9L,9H,OL,OH,1L,1H	49-51

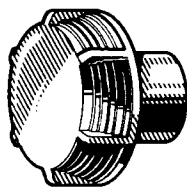

8H-18817

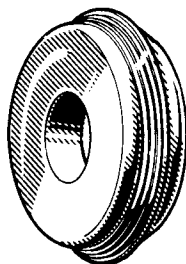

8H-18818

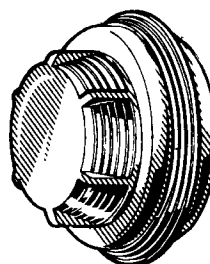

8H-18824

PL-247

8H 18817	Knob (radio receiver)-volume control	1	9L,9H	49
OL 18817	Knob assy (radio volume control)	2	OL,OH	50
1H 18817	Knob assy (radio volume control)	2	1L,1H	51
8H 18818	Disc (radio knob trim)-tone control	1	9L,9H	49
8H 18824	Knob (radio dial control)	1	9L,9H	49
OL 18830	Disc (radio tone and rear seat speaker volume control)	2	OL,OH,1L,1H	50-51



OL-18817

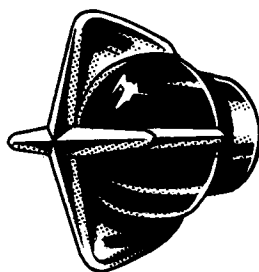

IH-18817

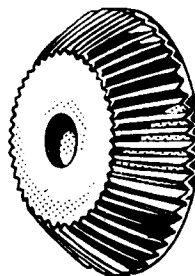

OL-18830

PL-647

8H 18842	Bezel (radio control)	1	9H	49
8L 18842	Bezel (radio control)	1	9L	49
	8L-7304416 Spacer (radio bezel)	2	9L,9H	49
	34803-S7 Lockwasher-No. 10	2	9L,9H	49
	34053-S8 Nut (hex)-No. 10-24	2	9L,9H	49
5EH 18848	Tee (vacuum antenna)	1	9L,9H,OL,OH,1L,1H	49-51
8M 18850	Rod and cylinder assy (radio antenna)	1	9L,9H	49
OL 18850	Rod and cylinder assy (radio antenna)	1	OL,1L	50-51
OH 18850	Rod and cylinder assy (radio antenna)	1	OH,1H	50-51

# Lincoln and Lincoln Cosmopolitan

## CHASSIS PARTS CATALOGUE

PART NUMBER	PART NAME	NO. REQ'D	MODEL	YEAR
<b>Accessories—Continued</b>				
<b>Radio—Continued</b>				
OL 18856	Button (radio knob opening plug)-used in cars w/o radio	2	OL,OH,LL,1H	50-51
	OL-7204371 Plate (radio opening cover)-used in cars without radio	1	OL,OH,LL,1H	50-51
	41556-S8 Screw (pan head self tapping)-No. 10-32 x 3/8"	2	OL,OH,LL,1H	50-51
8M 18863	Valve assy (radio antenna)-vacuum	1	9L,9H	49
OL 18863	Valve assy (radio antenna)-vacuum	1	OL,OH	50
1H 18863	Valve assy (radio antenna)-vacuum	1	LL,1H	51
5EH 18865-B	Nut (vacuum antenna dome)	1	9L,9H,OL,OH,LL,1H	49-51
8L 18888-A	Support (radio receiver rear)-6-7/16" long	1	9L	49
8L 18888-B	Support (radio receiver rear)-5-1/4" long	1	9L	49
8H 18888	Support (radio receiver rear)-7-7/8" long	1	9H	49
OL 18888	Support (radio receiver rear)-RH	1	OL,OH,LL,1H	50-51
OL 18890	Support (radio receiver rear)-LH	1	OL,OH,LL,1H	50-51
	24308-S7 Bolt (hex head)-1/4"-20 x 1/2"	2	OL,OH,LL,1H	50-51
	34805-S8 Lockwasher-1/4"	4	OL,OH,LL,1H	50-51
	33920-S8 Nut (hex)-1/4"-20-support to instrument panel and radio chassis	4	OL,OH,LL,1H	50-51
8M 18897	Insulator (radio antenna)	1	9L,OL,LL	49-51
8H 18897	Insulator (radio antenna)	1	9H	49
OH 18897	Insulator (radio antenna)	1	OH,1H	50-51
8M 18898	Gasket (radio antenna)	1	9L,OL,LL	49-51
8H 18898	Gasket (radio antenna)	1	9H	49
OH 18898	Gasket (radio antenna)	1	OH,1H	50-51
8L 18911	Knob (vacuum antenna control valve)	1	9L,9H	49
	OL-18513 Knob (antenna control)	1	OL,OH	50
	1L-18513 Knob assy (radio antenna control)	1	LL,1H	51
	OL-18598 Bezel (radio antenna control)	1	OL,OH,LL,1H	50-51
	27153-S7 Screw (rd-hd)-No. 10-32 x 1-1/8"	1	OL,OH,LL,1H	50-51
8M 18912	Grommet (antenna lead in seal)-Rubber	1	9L,9H,OL,OH,LL,1H	49-51
	8A-14608 Retainer assy (antenna hose through dash)	1	9L,9H,OL,OH,LL,1H	49-51
	33121-S8 Screw (round head self tapping) No. 14-14 x 1/2"-grommet to dash panel	2	9L,9H,OL,OH,LL,1H	49-51
OL 18926	Bezel (radio antenna control)	1	OL,OH	50
8H 18931-A	NS Hose (radio antenna)-70" long-make from 8M-18931-D	1	9H	49
8H 18931-B	NS Hose (radio antenna)-57" long-make from 8M-18931-D	1	9H	49
8H 18931-C	NS Hose (radio antenna)-25" long-make from 8M-18931-D	1	9H	49
8L 18931-A	NS Hose (radio antenna)-20" long-make from 8M-18931-D	1	9L	49
8L 18931-B	NS Hose (radio antenna)-45-1/2" long-make from 8M-18931-D	1	9L	49
8L 18931-C	NS Hose (radio antenna)-61-1/2" long-make from 8M-18931-D	1	9L	49
8M 18931-D	Hose (radio antenna)-25 ft. roll	1	9L,9H,OL,OH	49-50
OH 18931-A	NS Hose (radio antenna)-38" long-make from 8M-18931-D	1	OH,1H	50-51
OH 18931-B	NS Hose (radio antenna)-71-1/2" long-make from 8M-18931-D	1	OH,1H	50-51
OH 18931-C	NS Hose (radio antenna)-90" long-make from 8M-18931-D	1	OH,1H	50-51

# Lincoln and Lincoln Cosmopolitan

## CHASSIS PARTS CATALOGUE

PART NUMBER	QUANTITY	PART NAME	NO. REQ'D	MODEL	YEAR 19__
-------------	----------	-----------	-----------	-------	--------------

### Accessories—Continued

#### Radio—Continued

OL 18931-A	NS	Hose (radio antenna)-17-1/2" long-make from 8M-18931-D	1	OL, 1L	50-51
OL 18931-B	NS	Hose (radio antenna)-58" long-make from 8M-18931-D	1	OL, 1L	50-51
OL 18931-C	NS	Hose (radio antenna)-73" long-make from 8M-18931-D	1	OL, 1L	50-51
8M 18939		Bracket (radio antenna)	1	9L, 9H, OL, 1L	49-51
OH 18939-C		Bracket (radio antenna)	1	OH, 1H	50-51
		20304-S2 Bolt (hex-hd)-1/4"-20 x 7/16"	1	9L, 9H, OL	49-50
		34805-S8 Lockwasher-1/4"	1	9L, 9H	49
		33795-S7 Nut (hex)-1/4"-20	1	9L, 9H, OL	49-50
OH 18947		Spacer (radio antenna grounding)	1	OH, 1H	50-51
OL 18947		Spacer (radio antenna grounding)	1	OL, 1L	50-51
8M 18951		Extension assy (radio receiver support)	1	9L	49
8L 18954		Clamp (radio antenna hose)	1	9L, 9H, OL, OH, 1L, 1H	49-51
8M 18954	NS	Clamp (radio antenna hose)-use 8L-18954 for service	2	OL, OH, 1L, 1H	50-51
OL 18965		Bracket assy (radio antenna vacuum)	1	OL, 1L	50-51
		24308-S7 Bolt (hex head)-1/4"-20 x 1/2"-bracket to antenna	1	OL, OH, 1L, 1H	50-51
		34905-S7 Lockwasher-1/4"-bracket to antenna	1	OL, OH, 1L, 1H	50-51
		355862-S32 Nut (speed)-No. 14-bracket to splash apron	1	OL, OH, 1L, 1H	50-51
		31498-S8 Screw (hex washer head)-No. 14-10 x 5/8"-bracket to splash apron	1	OL, OH, 1L, 1H	50-51
8M 18966		Washer assy (vacuum antenna)	1	9L, 9H, OL, OH, 1L, 1H	49-51
		24308-S7 Bolt (hex-hd)-1/4"-20 x 1/2"	1	9L, 9H, OL, OH, 1L, 1H	49-51
		34905-S7 Lockwasher (internal tooth)-1/4"	1	9L, 9H, OL, OH, 1L, 1H	49-51

#### Reading and Vanity Light

HAK 18295-A		Kit (reading and vanity light installation)-consists of the following (1) FAA-18208-A Kit (mirror) (1) OH-18295-A Kit (map light)	1	9L, 9H, OL, OH, 1L, 1H	49-51
FAA 18208-A		Kit (visor vanity mirror installation)	1	9L, 9H, OL, OH, 1L, 1H	49-51
OH 18295-A	NS	Kit (visor mounted map light installation)-serviced in HAK-18295-A Kit	1	9L, 9H, OL, OH, 1L, 1H	49-51

#### Rear Door Safety Lock

HAK 18333-A		Kit (rear door safety lock installation)-consists of the following (12) 1H-18333 Lock Kit	1	9L74, 9H73-74, OL74, OH74, 1L74, 1H74	49-51
1H 18333	NS	Kit (rear door safety lock)-serviced in HAK-18333-A Kit	1	9L74, 9H73-74, OL74, OH74, 1L74, 1H74	49-51

# Lincoln and Lincoln Cosmopolitan

## CHASSIS PARTS CATALOGUE

### Accessories—Continued

#### Rear Fender Shield

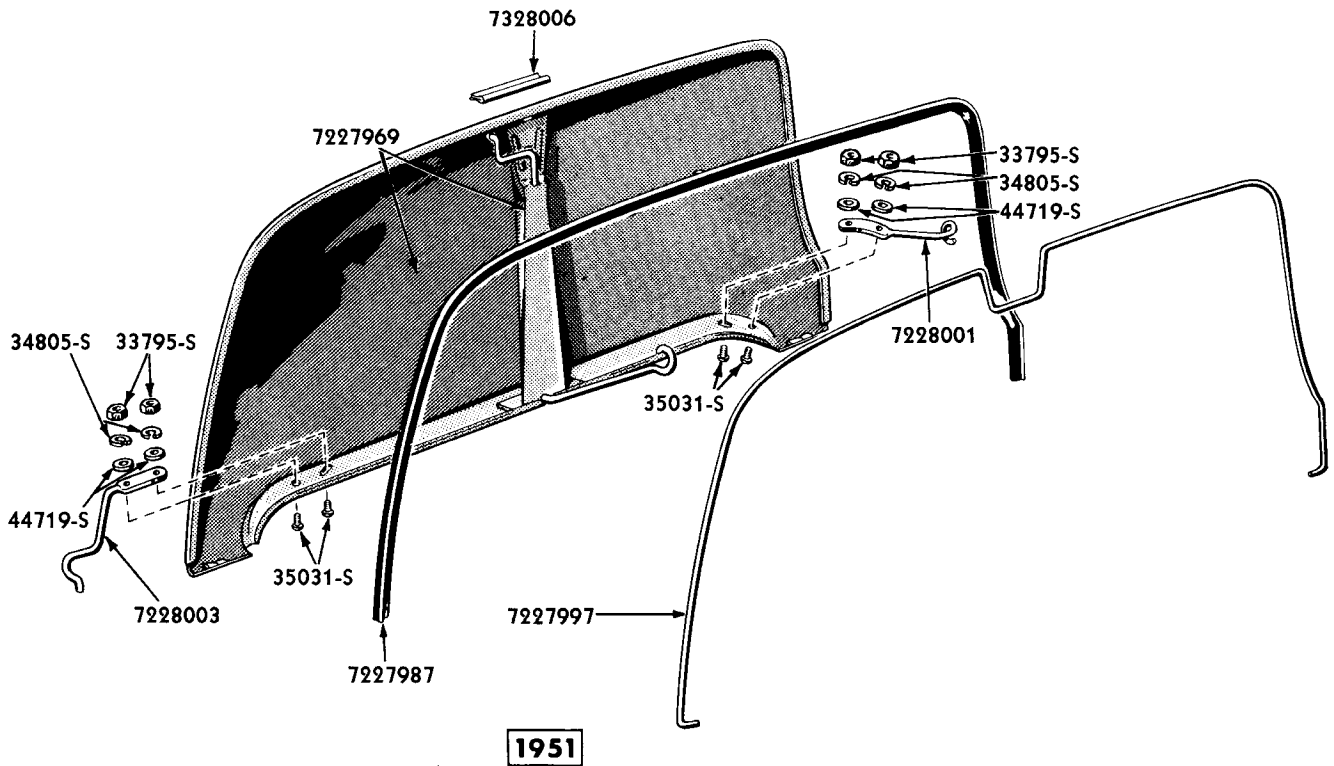

PM-465

#### REAR FENDER SHIELD

Basic numbers only shown on illustration. Order by Part Numbers shown in list of parts.

PART NUMBER	CLIP	PART NAME	NO. REQ'D	MODEL	YEAR
1L 18973	NS	Kit (rear fender shield installation)-consists of the following (1) 1L-7227968 Cover (1) 1L-7227969 Cover (1) 1L-7227986 Seal (1) 1L-7227987 Seal (1) 1L-7227996-B Retainer (1) 1L-7227997-B Retainer (1) 1L-7228000 Bracket (1) 1L-7228001 Bracket (1) 1L-7228002 Bracket (1) 1L-7228003 Bracket (2) 8L-7328006, Clip	1	1L	51
1L 7227968		Cover assy (quarter panel wheel opening)-RH	1	1L	51
1L 7227969		Cover assy (quarter panel wheel opening)-LH	1	1L	51
1L 7227986		Seal (quarter panel wheel opening cover)-RH-58-3/4" long	1	1L	51
1L 7227987		Seal (quarter panel wheel opening cover)-LH-58-3/4" long	1	1L	51
1L 7227996-B		Retainer (quarter panel wheel cover seal)-RH	1	1L	51
1L 7227997-B		Retainer (quarter panel wheel cover seal)-LH	1	1L	51

# Lincoln and Lincoln Cosmopolitan

## CHASSIS PARTS CATALOGUE

PART NUMBER	PART NAME	NO. REQ'D	MODEL	YEAR 19
-------------	-----------	-----------	-------	------------

### Accessories—Continued

#### Rear Fender Shield—Continued

1L 7228000	Bracket (quarter panel wheel opening cover)-front-RH	1	1L	51
1L 7228001	Bracket (quarter panel wheel opening cover)-front-LH	1	1L	51
1L 7228002	Bracket (quarter panel wheel opening cover)-rear-RH	1	1L	51
1L 7228003	Bracket (quarter panel wheel opening cover)-rear-LH	1	1L	51
8L 7328006	Clip (quarter panel wheel cover)	2	1L	51

#### Rear Seat Speaker

OH 18875	Speaker assy (rear seat)-Flush type	1	OL,OH,1L,1H, except 76	50-51
----------	-------------------------------------	---	------------------------	-------

#### Rear View Mirror (Outside)

8H 18402	Mirror assy (outside rear view)-RH	1	9H	49
1H 18402-B	Kit (rear view mirror installation)-outside-consists of the following (1) 1H-17682 Mirror (1) 1H-17710 Plate (1) 28442-S13 Screw (2) 32924-S8 Screw	1	1L,1H	51
8H 18403	Mirror assy (outside rear view)-LH	1	9H	49
	34803-S7 Lockwasher-No. 10	2	9H	49
1H 17682	NS Mirror assy (rear view)-serviced in 1H-18402-B Kit	1	1L,1H	51
	28442-S13 Screw (oval head machine)-No. 8-32 x 1-3/4"-mirror to plate	1	1L,1H	51
1H 17710	NS Plate (rear view mirror mounting)-serviced in 1H-18402-B Kit	1	1L,1H	51
	32924-S8 Screw (pan-hd self tapping)-No. 10-12 x 1/2"-plate to door panel	2	1L,1H	51

#### Rear Window Wiper

HAK 18387-A	Kit (rear window wiper installation)	1	OL,OH72-74,1H72-74	50-51
1L 18387-A	Kit (rear window wiper installation)	1	1L	51

#### Roadlamp

1H 18207-A	Kit (roadlamp installation)-consists of the following (1) OL-14369 Wire (2) OL-15200 Lamp (2) 1H-15209-A Prop (2) 1H-15211-A Washer (1) OL-15224 Switch (1) OL-15246 Wire (5) 1H-15226-A Clamp (1) OL-15248 Wire (1) 1H-15268-A Bezel (1) 1H-18817 Knob (2) 33802-S8 Nut (2) 34808-S8 Washer (2) 356687-S32 Clip	1	1L,1H	51
7RA 14197-B	Clip (roadlamp wire to stone deflector)	4	OL,OH	50
OL 14369	Wire assy (left roadlamp to right lamp)-37-1/2" long	1	OL,OH,1L,1H	50-51
7EH 15200-A	Roadlamp assy-amber lens	2	9L,9H	49
7EH 15200-B	NS Roadlamp assy-clear lens	2	9L,9H	49



# Lincoln and Lincoln Cosmopolitan

## CHASSIS PARTS CATALOGUE

### Accessories—Continued

### Roadlamp—Continued

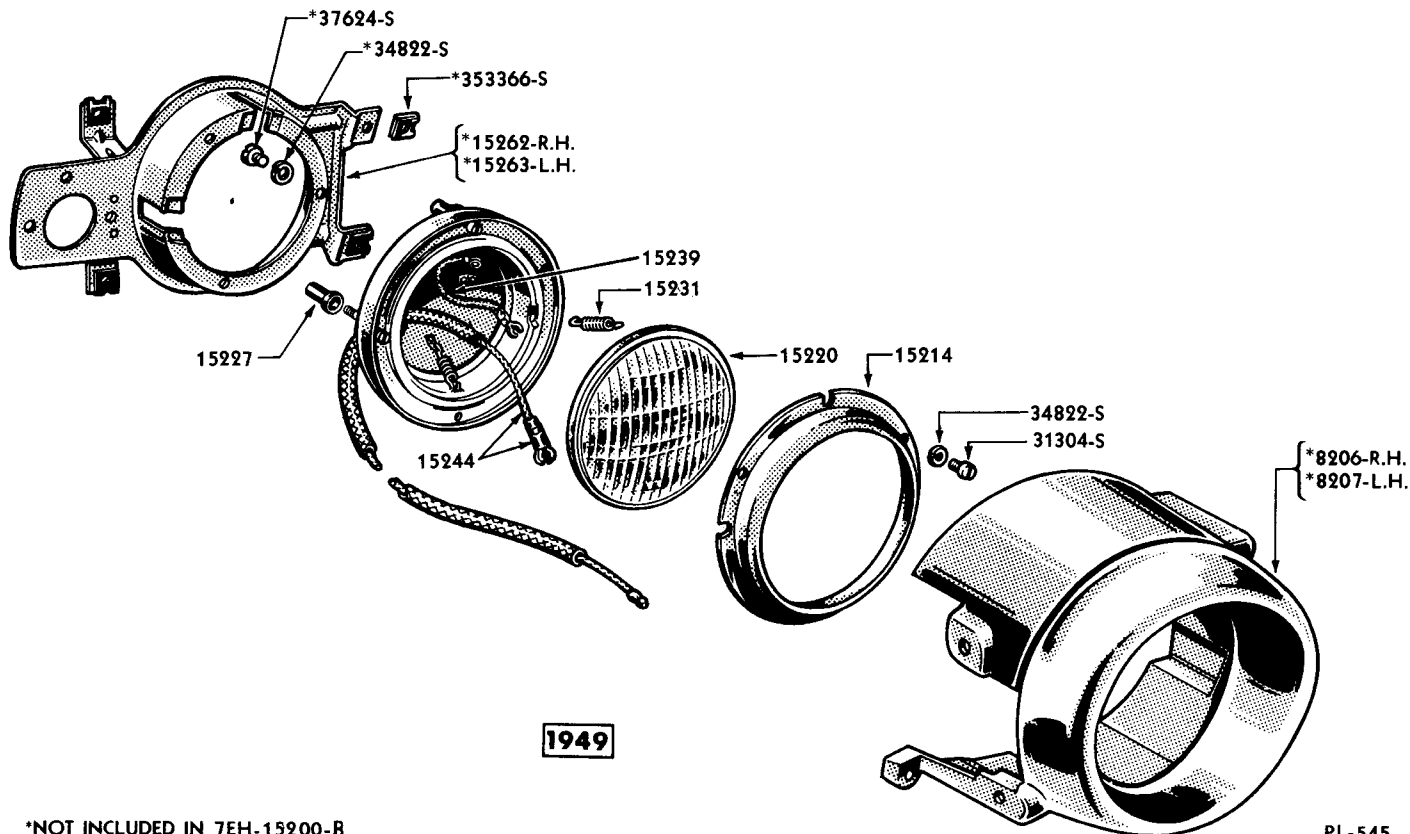

\*NOT INCLUDED IN 7EH-15200-B

PL-545

### ROADLAMP (7EH-15200-B) AND RELATED PARTS

Basic numbers only shown on illustration. Order by Part Numbers shown in list of parts.

PART NUMBER	QTY	PART NAME	NO. REQ'D	MODEL	YEAR
OL 15200		Roadlamp assy	2	OL,OH,1L,1H	50-51
		33802-S8 Nut (hex)-7/16"-20	2	OL,OH,1L,1H	50-51
		34808-S8 Lockwasher-7/16"	2	OL,OH,1L,1H	50-51
		7EH-8206-B Housing (grille roadlamp)-RH	1	9L,9H	49
		7EH-8207-B Housing (grille roadlamp)-LH	1	9L,9H	49
		32944-S2 Screw (pan head self tapping)- No. 10-12 x 7/8"	8	9L,9H	49
21T 15207		Adapter (roadlamp locating ring)	2	9L,9H,OL,OH	49-50
OM 15207		Retainer (roadlamp ring)-used with serrated rim	4	OL,OH,1L,1H	50-51
		26455-S8 Screw (rd-hd)-No. 4-40 x 1/4"- retainer to lamp door	4	OL,OH,1L,1H	50-51
1H 15209-A		Prop (roadlamp mounting)	2	1L,1H	51
1H 15211-A		Washer (roadlamp mounting)	2	1L,1H	51
7EH 15214		Ring (roadlamp retainer)	2	9L,9H	49
		34822-S7 Lockwasher-No. 8	6	9L,9H	49
		31304-S8 Screw (fillister head)-No. 8- 32 x 1/4"	6	9L,9H	49
OM 15214		Rim (roadlamp)-serrated	2	OL,OH,1L,1H	50-51
		30084-S13 Screw (oval head)-No. 8-32 x 1- 1/8"-door to lamp	2	OL,OH,1L,1H	50-51

# Lincoln and Lincoln Cosmopolitan

## CHASSIS PARTS CATALOGUE

### Accessories—Continued

### Roadlamp—Continued

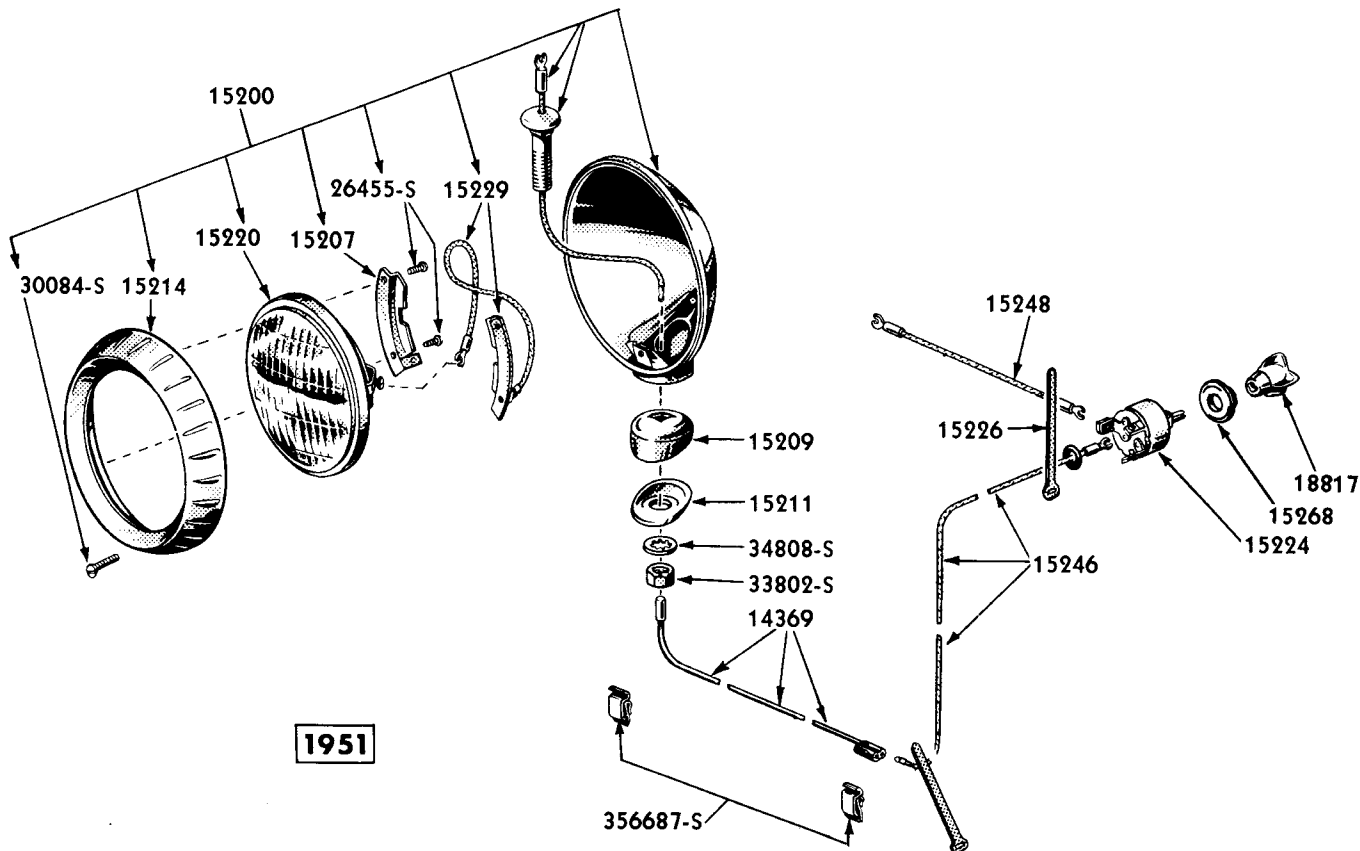

### ROADLAMP AND RELATED PARTS

PL-634

Basic numbers only shown on illustration. Order by Part Numbers shown in list of parts.

PART NUMBER	QTY	PART NAME	NO. REQ'D	MODEL	YEAR
11A 15220-B		Bulb (roadlamp)-Sealed Beam-clear lens	2	9L,9H,OL,OH,1L,1H	49-51
11A 15220-C		Bulb (roadlamp)-Sealed Beam-amber lens	2	9L,9H	49
8L 15224-B		Switch assy (roadlamp)-2-7/32" overall length	1	9L,9H	49
OL 15224		Switch (roadlamp)	1	OL,OH,1L,1H	50-51
		8L-7004658-F Tray assy (roadlamp switch)	1	9L,9H	49
		351230-S7 Lockwasher-No. 8	3	9L,9H,OL,OH,1L,1H	49-51
		351038-S8 Nut (check)-7/16"-28-switch to instrument panel	1	9L,9H	49
		26457-S7 Screw (round head)-No. 8-32 x 3/16"-wiring to switch	3	9L,9H,OL,OH,1L,1H	49-51
		350009-S8 Screw (socket head set)-No. 8-32 x 5/16"	1	9L,9H	49
1H 15226-A		Clamp (roadlamp wire)-strap-4" long	5	1L,1H	51
7EH 15227		Boot (roadlamp adjusting nut)-Rubber	4	9L,9H	49

# Lincoln and Lincoln Cosmopolitan

## CHASSIS PARTS CATALOGUE

PART NUMBER	SWR-PC	PART NAME	NO. REQ'D	MODEL	YEAR 19__
-------------	--------	-----------	-----------	-------	--------------

### Accessories—Continued

### Roadlamp—Continued

OM 15229		Ring (roadlamp unit retainer assy)-use with serrated rim	2	OL,OH,1L,1H	50-51
		26455-S8 Screw (round head)-No. 4-40 x 1/4"-ring unit retainer to door	4	OL,OH,1L,1H	50-51
5EH 15231		Spring (roadlamp adapter retainer)	6	9L,9H	49
7EH 15233		Clip (roadlamp wiring loom)	3	9L,9H	49
5EH 15239		Wire (roadlamp ground)-5" long	2	9L,9H	49
		34902-S8 Lockwasher-No. 8	2	9L,9H	49
7EH 15244		Wire assy (roadlamp lead)-30-1/2" long	2	9L,9H	49
		353266-SA1 Clip (roadlamp wire to grille mounting hole)	2	9L,9H	49
OL 15246		Wire assy (roadlamp switch to left lamp)-118-1/2" long	1	OL,OH,1L,1H	50-51
		356687-S32 Clip (roadlamp wire to hole in stone deflector)	1	OL,OH,1L,1H	50-51
		26457-S7 Screw (round head)-No. 8-32 x 1/4"	3	OL,OH,1L,1H	50-51
OL 15248		Wire assy (roadlamp switch to headlamp switch)-18-1/2" long	1	OL,OH,1L,1H	50-51
5EH 15258		Yoke (roadlamp adjusting screw)	4	9L,9H	49
7EH 15262		Reinforcement and bracket assy (road and parking lamp)-RH	1	9L,9H	49
7EH 15263		Reinforcement and bracket assy (road and parking lamp)-LH	1	9L,9H	49
		34804-S8 Lockwasher-No. 12	10	9L,9H	49
		353366-S32 Nut (speed)-No. 10 (5/8" x 41/64")	8	9L,9H	49
		355768-A-S2 Nut (speed)-No. 10 (7/16" x 17/32")	4	9L,9H	49
		32944-S2 Screw (pan head self tapping)-No. 10-12 x 7/8"-lamp assy to grille	8	9L,9H	49
		37624-S7 Screw (fillister head)-No. 12-24 x 5/16"-brkt. to roadlamp assy	6	9L,9H	49
		37657-S8 Screw (fillister head pointed)-No. 12-24 x 1/2"-bracket to parking lamp	4	9L,9H	49
OL 15268		Bezel (roadlamp switch)	1	OL,OH	50
1H 15268-A		Bezel (roadlamp switch)	1	1L,1H	51
OL 18817		Knob (roadlamp switch)	1	OL,OH	50
1H 18817		Knob assy (roadlamp switch)-Gold with black base-fin type	1	1L,1H	51
8L 18954		Clamp (roadlamp wire)-strap-3-5/32" long	5	OL,OH	50

# Lincoln and Lincoln Cosmopolitan

## CHASSIS PARTS CATALOGUE

PART NUMBER	QTY	PART NAME	NO. REQ'D	MODEL	YEAR
<b>Accessories—Continued</b>					
<b>Spotlight</b>					
8H 18154		Kit (spotlight bracket installation)-RH-consists of the following (1) 8H-15320 Bracket (1) 5EH-18576 Bracket (3) 32859-S13 Screw	1	9L76,9H,OH	49-50
8L 18154		Kit (spotlight bracket installation)-RH-consists of the following (1) 8L-15320 Bracket (1) 5EH-18576 Bracket (3) 32859-S13 Screw	1	9L72-74,OL,1L,1H72-74	49-51
8M 18154		Kit (spotlight bracket installation)-RH-consists of the following (1) 8M 15320 Bracket (1) 5EH-18576 Bracket (3) 32859-S13 Screw	1	1H76	51
8H 18155		Kit (spotlight bracket installation)-LH-consists of the following (1) 8H-15321 Bracket (1) 5EH-18576 Bracket (3) 32859-S13 Screw	1	9L76,9H,OH	49-50
8L 18155		Kit (spotlight bracket installation)-LH-consists of the following (1) 8L-15321 Bracket (1) 5EH-18576 Bracket (3) 32859-S13 Screw	1	9L72-74,OL,1L,1H72-74	49-51
8M 18155		Kit (spotlight bracket installation)-LH-consists of the following (1) 8M-15320 Bracket (1) 5EH-18576 Bracket (3) 32859-S13 Screw	1	1H76	51
OL 18148		Spotlight assy-less brackets	1	9L,9H,OL,OH,1L,1H	49-51
8H 15320	NS	Bracket (spotlight)-outer-RH-serviced in 8H-18154 Kit	1	9L76,9H,OH	49-50
8L 15320	NS	Bracket (spotlight)-outer-RH-serviced in 8L-18154 Kit	1	9L72-74,OL,1L,1H72-74	49-51
8M 15320	NS	Bracket (spotlight)-outer-RH-serviced in 8M-18154 Kit	1	1H76	51
8H 15321	NS	Bracket (spotlight)-outer-LH-serviced in 8H-18155 Kit	1	9L76,9H,OH	49-50
8L 15321	NS	Bracket (spotlight)-outer-LH-serviced in 8L-18155 Kit	1	9L72-74,OL,1L,1H72-74	49-51
8M 15321	NS	Bracket (spotlight)-outer-LH-serviced in 8M-18155 Kit	1	1H76	51
		32859-S13 Screw (round head self tapping)- No. 10-12 x 1/2"-bracket to body	3	9L,9H,OL,OH,1L,1H	49-51
8C 15328		Rim assy (spotlight)	1	9L,9H	49
OL 15328		Door (spotlight lens)	1	OL,OH,1L,1H	50-51
		355083-S13 Screw (oval head)-No. 8-32 x 5/8"-door to lamp	1	OL,OH,1L,1H	50-51

# Lincoln and Lincoln Cosmopolitan

## CHASSIS PARTS CATALOGUE

PART NUMBER	QTY	PART NAME	NO. REQ'D	MODEL	YEAR
-------------	-----	-----------	-----------	-------	------

### Accessories—Continued

#### Spotlight—Continued

6A 15330		Bulb assy (spotlight)-4-13/32" O.D.-Sealed Beam	1	9L,9H	49
8C 15330		Bulb assy (spotlight)-5-21/32" O.D.-Sealed Beam	1	9L,9H,OL,OH,LL,LH	49-51
51A 15332		Switch assy (spotlight)	1	9L,9H,OL,OH,LL,LH	49-51
		29546-S13 Screw (oval head)-No. 6-32 x 5/16"-switch to spotlight	1	9L,9H,OL,OH,LL,LH	49-51
5EH 18576	NS	Bracket (spotlight)-inner-serviced in 8H-18154, 8L-18154, 8H-18155, 8L-18155 Kits	1	9L,9H,OL,OH,LL,LH	49-51

#### Spare Tire Valve Air Extension

8L 18349		Extension assy (spare tire valve)	1	9L,OL,LL,LH	49-51
----------	--	-----------------------------------	---	-------------	-------

#### Utility Lamp

8H 15550		Lamp assembly (utility)-one bulb type	1	9L,9H,OL,OH,LL,LH	49-51
		51A-13465 Bulb (utility lamp)-15 C.P.-S.C.	1	9L,9H,OL,OH,LL,LH	49-51
1H 15550-A		Lamp assy (utility)-two bulb type	1	9L,9H,OL,OH,LL,LH	49-51
		B-13466 Bulb (utility lamp)-3 C.P.-S.C.-No. 63	1	9L,9H,OL,OH,LL,LH	49-51
		A-18570 Bulb (utility lamp)-32 C.P.-S.C.	1	9L,9H,OL,OH,LL,LH	49-51
HAK 15550-A		Kit (emergency utility lamp and case)-includes 1H-15550-A lamp	1	9L,9H,OL,OH,LL,LH	49-51

#### Vanity Mirror

FAA 18208-A		Kit (visor vanity mirror installation) (1) OH-13757 Mirror (2) OH-13814 Screw (2) OH-13816 Nut (4) OH-13817 Washer	1	9L,9H,OL,OH,LL,LH	49-51
OH 13757	NS	Mirror (visor vanity)-serviced in FAA-18208-A Kit	1	9L,9H,OL,OH,LL,LH	49-51
OH 13814	NS	Screw (mirror to visor)-serviced in FAA-18208-A Kit	2	9L,9H,OL,OH,LL,LH	49-51
OH 13816	NS	Nut (mirror to visor)-serviced in FAA-18208-A Kit	2	9L,9H,OL,OH,LL,LH	49-51
OH 13817	NS	Washer (mirror to visor)-serviced in FAA-18208-A Kit	4	9L,9H,OL,OH,LL,LH	49-51

#### Windshield Washer

OH 18293	NS	Kit (automatic W/S washer installation)-consists of the following (1) OM-17574 Reservoir (1) OH-17580 Hose (1) OH-17583 Hose (1) 51A-17587 Tee (1) 51A-17615 Fitting (1) OM-17642 Valve (1) OM-17664 Pump (2) 51A-17666 Jet (3) 8L-18954 Clamp (3) 32873-S7 Screw	1	9L,9H,OL,OH,LL,LH	49-51
----------	----	--	---	-------------------	-------

# Lincoln and Lincoln Cosmopolitan

## CHASSIS PARTS CATALOGUE

### Accessories—Continued

### Windshield Washer—Continued

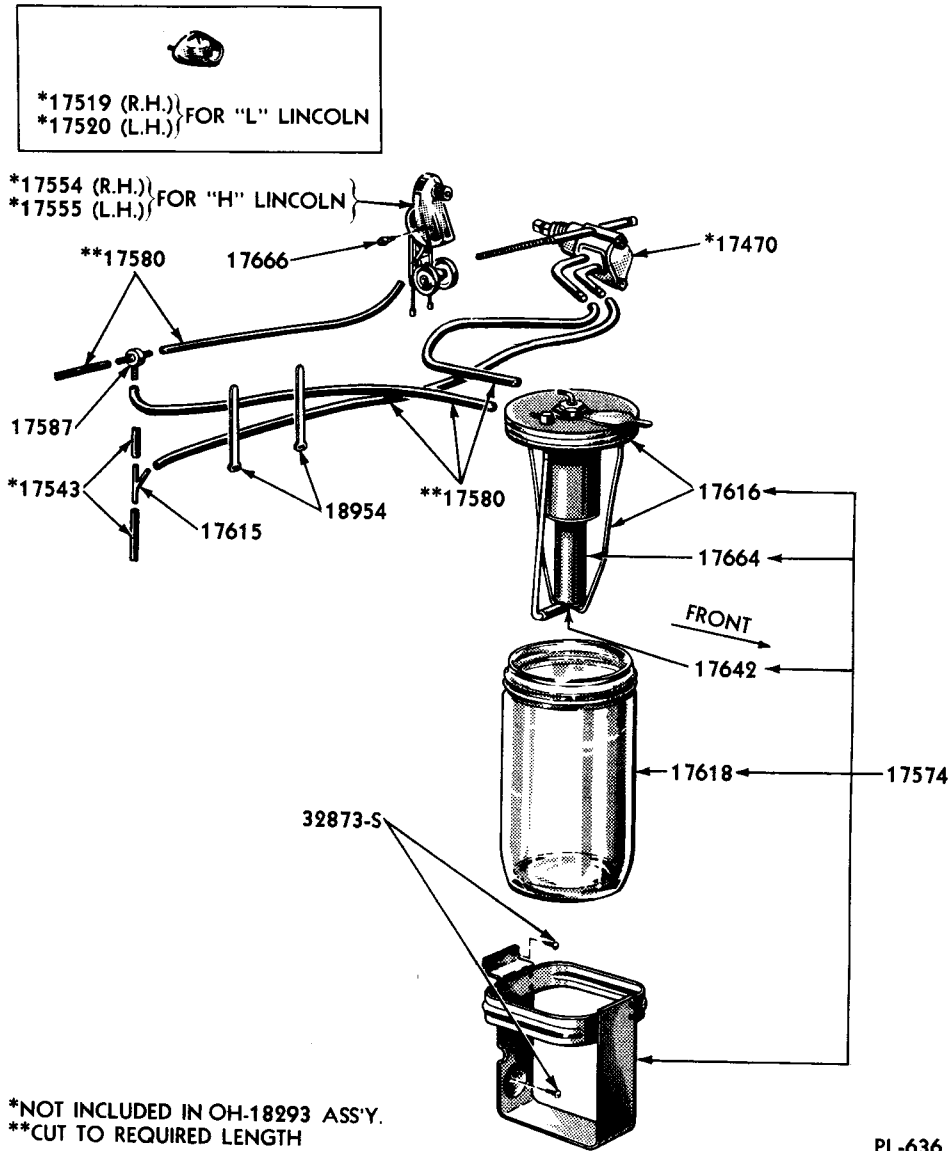

PL-636

### WINDSHIELD WASHER

Basic numbers only shown on illustration. Order by Part Numbers shown in list of parts.

PART NUMBER	QUANTITY	PART NAME	NO. REQ'D	MODEL	YEAR
5EH 17574		Reservoir, bracket and injector assy (w/s washer)	1	9L, 9H	19
OM 17574	NS	Reservoir and injector assy (w/s washer)	1	9L, 9H, 9L, 9H, 1L, 1H	49
		32873-S7 Screw (round head self tapping) -No. 10-12 x 3/4"	3	9L, 9H, 9L, 9H, 1L, 1H	49-51
		8M-17616 Cap and injector assy (w/s washer)	1	9L, 9H, 9L, 9H, 1L, 1H	49-51
		8M-17618 Jar (w/s washer)-round-Glass	1	9L, 9H, 9L, 9H, 1L, 1H	49-51



# Lincoln and Lincoln Cosmopolitan

## CHASSIS PARTS CATALOGUE

PART NUMBER	PART NAME	NO. REQ'D	MODEL	YEAR
<b>Miscellaneous Kits</b>				
HBK 1141-A	Kit (hub cap medallion)-consists of the following (1) 1L-1141-A Medallion (2) 355914-S32 Nut	4	1L720, 1H720	51
8L 2001-C	Kit (front brake shoe and lining)-.182"/.192" thick lining-with short primary lining-consists of the following (2) 8L-2018-D Shoe & lining (front brake)-primary (2) 8L-2019-B Shoe & lining (front brake)-secondary	1	9L, 9H, 0L, 0H	49-50
0L 2001	Kit (brake shoe and lining)-complete car-marked with (2) white paint stripes-consists of the following (2) 8L-2018-D Shoe and lining-front primary (2) 8L-2218-D Shoe and lining-rear primary (2) 0L-2019-B Shoe and lining-front secondary (2) 0L-2219-B Shoe and lining-rear secondary	1	9L, 9H, 0L, 0H, 1L, 1H	49-51
HAK 2001-A	Kit (front brake shoe and lining)-.182"/.192" thick-Standard-Axle Set-consists of the following (2) 8L-2018-D Shoe and lining-primary (2) 0L-2019-B Shoe and lining-secondary	1	9L, 9H, 0L, 0H, 1L, 1H	49-51
8M 2004	Kit (brake master cylinder repair)-consists of the following (2) 8M-2152 Gasket (1) 51A-2169 Piston (1) 51A-2173 Cup (1) 51A-2174 Snap ring (1) 51A-2178 Valve (1) 91A-2180-A Boot	1	9L, 9H, 0L, 0H, 1L, 1H	49-51
8L 2007-A	Kit (front brake lining)-.202"/.222" thick-consists of the following (2) 8L-2021-A Lining-primary (2) 8L-2022-A Lining-secondary (45) 351939-S Rivet	1	9L, 9H	49
8L 2007-B	Kit (front brake lining)-.182"/.192" thick-consists of the following (2) 8L-2021-B Lining-primary (2) 8L-2022-B Lining-secondary (45) 351939-S Rivet	1	9L, 9H	49
8L 2007-C	Kit (front brake lining)-.182"/.192" thick-with short primary lining-consists of the following (2) 8L-2021-D Lining-primary (2) 8L-2022-B Lining-secondary (45) 351939-S Rivet	1	9L, 9H, 0L, 0H	49-50
0L 2007	Kit (brake lining)-complete car-marked with (2) white paint stripes-consists of the following (2) 8L-2021-D Lining-front primary (2) 8L-2284-D Lining-rear primary (2) 0L-2022-B Lining-front secondary (2) 0L-2285-B Lining-rear secondary (88) 351939-S Rivet			
HAK 2007-A	Kit (front brake lining)-.182"/.192" thick-Standard-Axle set-consists of the following (2) 8L-2021-D Lining-primary (2) 0L-2022-B Lining-secondary (40) 351939-S Rivet	1	9L, 9H, 0L, 0H, 1L, 1H	49-51



# Lincoln and Lincoln Cosmopolitan

## CHASSIS PARTS CATALOGUE

PART NUMBER	PART NAME	NO. REQ'D	MODEL	YEAR 19
<b>Miscellaneous Kits—Continued</b>				
8L 2128	Kit (rear wheel brake cylinder repair)-consists of the following (2) 8L-2201 Cup (2) 96H-2206 Boot	1	9L,9H,OL,OH,LL,LH	49-51
8L 2200-A	Kit (rear brake shoe and lining)-.202"/.222" thickness lining-consists of the following (2) 8L-2218-A Shoe & lining (rear brake)-primary (2) 8L-2219-A Shoe & lining (rear brake)-secondary	1	9L,9H	49
8L 2200-C	Kit (rear brake shoe and lining)-.182"/.192" thick-with short primary lining-consists of the following (2) 8L-2218-D Shoe and lining-primary (2) 8L-2219-B Shoe and lining-secondary	1	9L,9H,OL,OH	49-50
HAK 2200-A	Kit (rear brake shoe and lining)-.182"/.192" thick-Standard-Axle Set-consists of the following (2) 8L-2218-D Shoe and lining-primary (2) OL-2219-B Shoe and lining-secondary	1	9L,9H,OL,OH,LL,LH	49-51
8M 2221	Kit (front wheel brake cylinder repair)-consists of the following (2) 91A-2202 Cup (2) OM-2207-A Boot	1	9L,9H,OL,OH,LL,LH	49-51
8L 2222-A	Kit (rear brake lining)-consists of the following (2) 8L-2284-A Lining-primary (2) 8L-2285-A Lining-secondary (45) 351939-S Rivet	1	9L,9H	49
8L 2222-B	Kit (rear brake lining)-.182"/.192" thick-consists of the following (2) 8L-2284-B Lining-primary (2) 8L-2285-B Lining-secondary (45) 351939-S Rivets	1	9L,9H	49
8L 2222-C	Kit (rear brake lining)-.182"/.192" thick-with short primary lining-consists of the following (2) 8L-2284-D Lining-primary (2) 8L-2285-B Lining-secondary (45) 351939-S Rivet	1	9L,9H,OL,OH	49-50
HAK 2222-A	Kit (rear brake lining)-.182"/.192" thick-Standard-Axle Set-consists of the following (2) 8L-2284-D Lining-primary (2) OL-2285-B Lining-secondary (40) 351939-S Rivet	1	9L,9H,OL,OH,LL,LH	49-51
HAK 2452-A	Kit (brake or clutch pedal extension)-consists of the following (1) 1H-22456-A Plate (1) 1H-22457-A Base (1) 1H-22460-A Retainer (2) 72857-S Pin (1) 350479-S2 Bolt (1) 356060-S32 Nut	1	9L,9H,OL,OH,LL,LH	49-51
HAK 2452-B	Kit (brake or clutch pedal extension additive)-consists of the following (1) 1H-22456-A Plate (2) 72857-S Pin	1	9L,9H,OL,OH,LL,LH	49-51

# Lincoln and Lincoln Cosmopolitan

## CHASSIS PARTS CATALOGUE

PART NUMBER	PART NAME	NO. REQ'D	MODEL	YEAR
<b>Miscellaneous Kits—Continued</b>				
8M 3047	Kit (front suspension upper inner shaft)-consists of the following (1) 8M-3056 Shaft (2) 8M-3062 Bushing (2) 8M-3076 Seal	2	9L,9H,OL,OH,LL,1H	49-51
8M 3048	Kit (front suspension lower inner shaft)-consists of the following (1) 8M-3057 Shaft (2) 8M-3063 Bushing (2) 8M-3074 Seal	2	9L,9H,OL,OH,LL,1H	49-51
8M 3049	Kit (front suspension upper arm to spindle support bolt)-consists of the following (1) 8M-3046 Bushing (1) 8M-3072 Bolt (2) 8M-3075 Seal (2) 34913-S Lockwasher (1) 351146-S7 Nut	2	9L,9H,OL,OH,LL,1H	49-51
8M 3050	Kit (front suspension lower arm to spindle support bolt)-consists of the following (1) 8M-3073 Bolt (2) 8M-3088 Seal (1) 8M-3089 Bushing (1) 351149-S7 Nut (2) 356586-S2 Lockwasher	2	9L,9H,OL,OH,LL,1H	49-51
8M 3111	Kit (spindle bolt and bushing)-consists of the following (4) 8M-3110 Bushing (2) 8M-3115 Pin (2) HB-3123-A Bearing (4) 74121-S Plug (2) 352656-S8 Pin	1	9L,9H,OL,OH,LL,1H	49-51
8M 3270	Kit (steering spindle connecting rod end)-consists of the following (1) 8M-3289 End (1) 8M-3332 Seal (1) 72016-S Cotter pin(1) 351059-S7 Nut (1) 353043-AS7 Fitting	2	9L,9H,OL,OH,LL,1H	49-51
HAK 3352-A	Kit (steering idler arm)-consists of the following (1) 8M-3355 Arm (2) OM-3356 Bushing (2) 8M-3359 Seal (1) 353047-AS7 Fitting (1) 358011-S7 Fitting	1	9L,9H,OL,OH,LL,1H	49-51
LAK 5560-A	Kit (rear spring service leaf)-consists of the following (2) OM-5565 Leaf (2) 350323-S2 Bolt (2) 33798-S8 Nut	1	9L,OL	49-50
8M 5630-A	Kit (rear spring rear shackle and front bolt)-consists of the following (1) 8M-5627-A Bar (1) 8M-5713-A Studs and shackle (6) 8M-5719 Bushing (1) 8M-5780-A Pin (3) 34397-S8 Locknut	2	9L,9H	49
OM 5630	Kit (rear spring rear shackle and front bolt)-consists of the following (1) OM-5627 Bar (1) OM-5713 Studs & shackle (6) 8M-5719 Bushing (1) OM-5780 Pin (3) 34397-S8 Lockwasher	1	OL,OH,LL,1H	50-51

# Lincoln and Lincoln Cosmopolitan

## CHASSIS PARTS CATALOGUE

PART NUMBER	SUB-PTC	PART NAME	NO. REQ'D	MODEL	YEAR
<b>Miscellaneous Kits—Continued</b>					
SEL 6008		Kit (engine overhaul gasket)-consists of the following (1) 8EL-6020 Gasket (2) 8EL-6051-D Gasket (1) 8EL-6344-B Gasket (1) 8EL-6521 Gasket (1) 8EL-6626 Gasket (2) 8EL-6643 Seal (1) 8EL-6659 Gasket (1) 8EL-6669 Gasket (1) 8EL-6698 Gasket (1) 8EL-6700 Packing (2) 8EL-6701-B Packing (1) 8EL-6707 Packing (2) 8EL-6710 Gasket (1) B-6734 Gasket (2) 8EL-8255-C Gasket (1) 8EL-8507-B Gasket (1) 8EL-8508-B Gasket (1) 8EL-9374 Gasket (1) 7RA-9417 Gasket (6) 7EH-9448-A Gasket (3) 8EL-9450 Gasket (1) 8EL-9458 Gasket (1) 7EH-9603 Spacer (1) 8EL-9654 Gasket	1	9L,9H,0L,0H,1L,1H	49-51
HAK 6028-A		Kit (frame conversion)-engine front supports-consists of the following (1) 8M-6028 Bracket (1) 8M-6029 Bracket (2) 8L-6038-B Insulator (2) 8L-6039 Insulator (2) 33850-S2 Nut (2) 33938-S7 Nut (2) 34811-S2 Washer (2) 72017-S Pin (2) 350721-S8 Bolt	1	9L,9H,0L,0H,1L,1H	49-51
HAK 6054-A		Kit (frame conversion)-engine rear supports-consists of the following (1) 8M-2153-A Bracket (1) 8L-6039 Insulator (1) 8L-6054-B Plate (1) 8L-6068-D Insulator (2) 20392-S Nut (1) 24389-S8 Bolt (1) 34445-S7 Locknut (3) 34449-S7 Nut (2) 34809-S2 Lockwasher (1) 8L-66073 Bolt (1) 356474-S8 Washer	1	9L,9H,0L,0H,1L,1H	49-51
HBK 6079-A		Kit (cylinder head gasket)-consists of the following (2) OEL-6051 Gasket (1) 8EL-6521 Gasket	1	9L,9H,0L,0H,1L,1H	49-51
HAK 6303-A		Kit (c/shaft conversion)-consists of the following (1) 8EL-6303-B Crankshaft and plugs (1) 8L-7938 Bearing (1) 8L-7942 Retainer	1	9L,9H,0L,0H,1L,1H	49-51
8CM 6731-A		Kit (oil filter element)-consists of the following (1) 7HA-6744-A Element (2) 01A-6746 Gasket (1) 01A-6885 Gasket	1	9L,9H,0L,0H,1L,1H	49-51
8EL 6781		Kit (oil pan gasket)-consists of the following (1) 8EL-6701-B Packing (1) 8EL-6707 Packing (2) 8EL-6710 Gasket	1	9L,9H,0L,0H,1L,1H	49-51
01Y 7039		Kit (universal joint)-consists of the following (4) 01Y-7074 Bearing (1) 01Y-7084 Spider (4) 01Y-7096 Snap ring	2	9L,9H,0L,0H,1L,1H	49-51

# Lincoln and Lincoln Cosmopolitan

## CHASSIS PARTS CATALOGUE

PART NUMBER	PART NAME	NO. REQ'D	MODEL	YEAR
<b>Miscellaneous Kits—Continued</b>				
8L 7153-B	Kit (transmission and overdrive gasket)-consists of the following (1) 56H-6932 Gasket (1) 8L-7051-A Gasket (1) 8L-7051-B Gasket (1) 8L-7051-C Gasket (1) 8L-7051-D Gasket (1) 8L-7086 Gasket (1) 8L-7223 Gasket (1) 8L-7661 Gasket (1) 8M-7778 Gasket (1) 8M-17275 Gasket	1	9L,9H	49
OEL 8570-A	Kit (thermostat and gasket)-157° to 162° opening temperature-consists of the following (2) 8EL-8255-C Gasket (2) 7HT-8575-B Thermostat	1	9L,9H,OL,OH,LL,1H	49-51
OEL 8570-B	Kit (thermostat and gasket)-177° to 182° opening temperature-consists of the following (2) 8EL-8255-C Gasket (2) 7HT-8575-C Thermostat	1	9L,9H,OL,OH,LL,1H	49-51
8EL 8591	Kit (water pump repair)-consists of the following (1) 8EL-8507-B Gasket (1) 8EL-8508-B Gasket (1) 8EL-8512-B Impeller (1) 7RA-8564-B Seal (1) 7EA-8576 Retainer (1) 8EL-8578-A Bearing	1	9L,9H,OL,OH,LL,1H	49-51
8EL 9349	Kit (fuel pump repair)-consists of the following (4) 1BA-9352-A Valve (1) 40-9357 Washer (1) 11A-9361 Plate (1) 49B-9364 Gasket (1) 8EL-9365 Screen (2) 49B-9367 Gasket (1) 11A 9367 Gasket (1) 7RA-9378 Pin (1) 7RA-9380 Spring (1) 8EL-9381 Link (1) 7RA-9382 Spacer (1) 7RA-9389 Bushing (1) 8EL-9396 Spring (1) 8EL-9398-A Diaphragm (1) 49B-9408 Gasket (1) 7RA-9417 Gasket (1) 49B-9418 Washer (2) 1BA-9468-A Retainer (1) 49B-9469 Oil Seal (1) 1BA-9469-A Oil Seal (1) 8EL-99361 Plate (1) 7RA-99367 Gasket (1) 7RA-99368 Screen (1) 8EL-99380 Link (1) 8EL-99381 Link (1) 8EL-99390 Diaphragm (1) 8EL-99396 Spring (2) 26466-S6 Screw (1) 27068-S7 Screw (4) 31628-S7 Screw (4) 34803-S7 Lockwasher (2) 352896-S Washer	1	9L,9H,OL,OH,LL,1H	49-51
HBK 9349-A	Kit (fuel and vacuum pump repair)-consists of the following (6) 1BA-9352-A Valve (1) 49B-9364 Gasket (2) 49B-9367 Gasket (1) 7RA-9378 Pin (1) 1BA-9380-B Spring (1) 49B-9381 Link (1) 7RA-9382 Spacer (1) 7RA-9389 Bushing (1) 8EL-9396 Spring (1) 49B-9397 Gasket (1) 1EL-9398-A Diaphragm (1) 8EL-9417 Gasket (1) 49B-9418 Washer (2) 1BA-9468-A Retainer (2) 1BA-9469-A Seal (3) 1BA-99367-A Gasket (1) 1EL-99380-A Link (1) 1EL-99381-A Link (1) 1EL-99390-A Diaphragm (1) 8EL-99396 Spring (2) 352896-S Washer	1	1L,1H	51
8EL 9433	Kit (exhaust manifold gasket)-consists of the following (6) 7EH-9448-A Gasket (3) 8EL-9450 Gasket (1) 8EL-9453 Gasket	1	9L,9H,OL,OH,1L,1H	49-51

# Lincoln and Lincoln Cosmopolitan

## CHASSIS PARTS CATALOGUE

PART NUMBER	PART NAME	NO. REQ'D	MODEL	YEAR
<b>Miscellaneous Kits—Continued</b>				
8CM 9502	Kit (carburetor gasket)-consists of the following (1) 8CM-9516 Gasket (1) 8CM-9519 Gasket (1) 78-9535 Packing (1) 8CM-9569 Gasket (1) 8CM-9608 Gasket (1) 8CM-9853 Gasket (1) 8CM-9871 Gasket (1) 8CM-9945 Gasket (2) 8CM-9985 Gasket	1	9L, 9H, 0L, 0H, 1L, 1H	49-51
8EL 9590-A	Kit (carburetor repair)-consists of the following (1) 8EL-9526 Link (2) 78-9541 Needle (1) 8CM-9558 Pin (1) 1CM-9564-B Needle (1) 78-9575 Retainer (1) 78-9576 Ball (2) 40-9578 Spring (1) 1GA-9578 Spring (6) 40-9586 Screw (1) 8CM-9631 Piston (1) 8CM-9902 Needle (1) 8CM-9987 Retainer (1) 34740-S8 Washer (2) 43262-S8 Screw (3) 352200-S Pin (1) 352884-S8 Washer (1) 352892-S8B Screw (1) 352895-S8 Pin	1	9L, 9H	49
8EL 9590-B	Kit (carburetor repair)-consists of the following (1) 8CM-9526-A Link (2) 78-9541 Needle (1) 8CM-9558 Pin (1) 1CM-9564-B Needle (1) 78-9575 Retainer (1) 78-9576 Ball (2) 40-9578 Spring (1) 1GA-9578 Spring (6) 40-9586 Screw (1) 8CM-9631 Piston (1) 8CM-9902 Needle (1) 8CM-9987 Retainer (1) 34740-S8 Washer (2) 43262-S8 Screw (3) 352200-S Pin (1) 352884-S8 Washer (1) 352892-S8B Screw (1) 352895-S8 Pin	1	9L, 9H	49
HAK 9590-A	Kit (carburetor repair)-consists of the following (1) 8EL-9526 Link (2) 78-9541 Needle (1) 8CM-9558 Pin (1) 1CM-9564-A or B Needle (1) 78-9575 Retainer (1) 78-9576 Ball (2) 40-9578 Spring (1) 1GA-9578 Spring (6) 40-9586 Screw (1) 8CM-9631 Piston (1) 8CM-9902 Needle (1) 34740-S8 Washer (2) 43262-S8 Screw (3) 352200-S Pin (1) 352892-S8B Screw (1) 352895-S8 Pin (1) 356366-S8 Washer	1	9L, 9H, 0L, 0H, 1L, 1H	49-51
HAK 9735-A	Kit (accelerator pedal installation)-consists of the following (1) 1H-9735-A Pedal (2) 32690-3 Screw	1	9L, 9H, 0L, 0H, 1L, 1H	49-51
8EL 9995-A	Kit (carburetor metering repair)-normal to 5,000 ft. altitude-consists of the following (2) 8EL-9533-A Jet (2) 8CM-9542 Jet (1) 8EL-9594 Valve (1) 8CM-9904-B Piston (2) 8CM-9991-A Tube	1	9L, 9H	49
8EL 9995-D	Kit (carburetor metering repair)-normal to 5,000 ft. altitude-consists of the following (2) 8EL-9533-A Jet (2) 8CM-9542 Jet (1) 8EL-9594 Valve (1) 8CM-9904-B Piston (2) 8EL-9991 Tube	1	9L, 9H, 0L, 0H, 1L, 1H	49-51

# Lincoln and Lincoln Cosmopolitan

## CHASSIS PARTS CATALOGUE

PART NUMBER	PART NAME	NO. REQ'D	MODEL	YEAR 19__
<b>Miscellaneous Kits - Continued</b>				
01A 10043	Kit (generator brush)-consists of the following (2) 01A-10069 Brush assy	1	9L,9H,OL,OH,1L,1H	49-51
18 11057	Kit (starter brush)-consists of the following (2) 18-11055 Brush (2) 18-11056 Brush	1	9L,9H,OL,OH,1L,1H	49-51
8EL 12259	Kit (spark plug and coil high tension wire)-consists of the following (1) 8EL-12282 Wire (1) 8EL-12283 Wire (1) 8EL-12284 Wire (1) 8EL-12285 Wire (1) 8EL-12286 Wire (1) 8EL-12287 Wire (1) 8EL-12295 Wire (1) 8EL-12296 Wire (1) 8EL-12298 Wire (10) 2N-12113 Insulator	1	9L,9H,OL,OH,1L,1H	49-51
8EL 12322	Kit (distributor governor weight spring)	1	9L,9H	49
B 14527	Kit (fuse)-20 amp.-consists of the following (5) B-14526 Fuse	1	9L,9H,OL,OH,1L,1H	49-51
APA 14527-B	Kit (fuse)-3 amp.-consists of the following (5) 51A-14526-B Fuse	as req'd	9L,9H,OL,OH,1L,1H	49-51
APA 14527-D	Kit (fuse)-14 amp.-consists of the following (5) 8A-14526 Fuse	as req'd	9L,9H,OL,OH,1L,1H	49-51
MAK 17528-A	Kit (w/s wiper arm and blade display)-consists of the following (12) MAK-17528-C Blade (4) MAK-17528-B Blade (4) OH-17528 Blade (4) 8H-17528-B Blade (2) OH-17526 Arm (2) 1H-17593 Insert (4) MAK-17464-A Arm	as req'd	9L,9H,OL,OH,1L,1H	49-51
HAK 18045-A	Kit (front shock absorber bushing)-consists of the following (2) 8M-18031 Seat (4) 8M-18041 Washer (4) 8M-18198 Insulator (2) 45218-S8 Locknut	1	9L,9H,OL,OH,1L,1H	49-51
HAK 18080-A	Kit (rear shock absorber bushing)-consists of the following (2) 8M-18039 Washer (2) 51A-18040 Washer (4) 51A-18197 Bushing	1	9L,9H,OL,OH,1L,1H	49-51
8H 18344	Kit (spark plug insulator installation)-consists of the following (8) 8H-12425 Insulators	1	9L,9H,OL,OH,1L,1H	49-51
1EL 18368-A	Kit (thermostat)-177° to 182° opening temperature -consists of the following (2) 8EL-8255-C Gasket (2) 1HA-8575-A	1	9L,9H,OL,OH,1L,1H	49-51
8L 22009	Kit (brake spring repair)-consists of the following (4) 96H-2036 Spring (8) 6H-2066 Cup (4) H-2068 Spring (4) 8L-2069 Pin (2) H-2092 Plate	1	9L,9H,OL,OH,1L,1H	49-51

# Lincoln and Lincoln Cosmopolitan

## CHASSIS PARTS CATALOGUE

PART NUMBER	PART NAME	NO. REQ'D	MODEL	YEAR 19
<b>Miscellaneous Kits—Continued</b>				
HBK 77167-A	Kit (trans. reverse clutch piston seals)-consists of the following (1) 1L-77167-A Seal (1) 1L-77174-A Seal	1	1L,1H	51
8L 77211	Kit (trans. throttle shaft repair)-consists of the following (1) 72187-S7 Pin (1) 8L-77233 Seal (1) 351543-S Washer	1	9L,9H,OL,OH,1L,1H	49-51
8L 77330	Kit (trans. front pump screws and washers)-consists of the following (3) 352792-S Bolt (1) 8L-77339 Bolt (3) 8L-77336 Washer (1) 34805-S Washer	1	9L,9H,OL,OH,1L,1H	49-51
HBK 77330-A	Kit (trans. front pump screws and washers)-consists of the following (3) 8L-77336 Washer (1) 1L-77339-A Bolt (1) 34805-S8 Washer (3) 352792-S Bolt	1	1L,1H	51
8L 77360	Kit (trans. rear oil pump driven gear)-consists of the following (1) 8L-77358 Gear (1) 72869-S Pin (1) 72909-S Pin	1	9L,9H,OL,OH,1L,1H	49-51
HBK 77383-A	Kit (trans. pressure regulator plugs and gaskets)-consists of the following (1) 0L-77355 Seal (1) 0L-77382 Gasket (1) 1L-77383-A Plug (1) 1L-77384-A Valve	1	1L,1H	51
8L 77388	Kit (trans. governor drive flange)-consists of the following (1) 72909-S Pin (1) 8L-77389 Flange	1	9L,9H,OL,OH,1L,1H	49-51
8L 77448	Kit (trans. rear servo check valve)-consists of the following (1) Rivet (flat head) (1) Valve (rear servo check)	1	9L,9H,OL,OH,1L,1H	49-51
HAK 77475-A	Kit (trans. rear servo compensator piston & spring)-consists of the following (1) 1L-77455-A Spring (1) 1L-77475-A Piston (1) 1L-77745-A Valve	1	9L,9H,OL,OH,1L,1H	49-51
8L 77535	Kit (trans. clutch piston seal and expander)-consists of the following (1) Expander (piston oil seal)-inner (1) Expander (piston oil seal)-outer (1) Seal (piston)-2-7/8" diameter (1) Seal (piston)-5-1/8" diameter	2	9L,9H,OL,OH,1L,1H	49-51
8L 77769	Kit (trans. manual control shaft seal and washer)-consists of the following (1) Washer (manual shaft seal)-inner (1) Washer (manual shaft seal)-outer (1) Seal (manual shaft)	1	9L,9H,OL,OH,1L,1H	49-51

# *Lincoln and Lincoln Cosmopolitan*

## CHASSIS PARTS CATALOGUE

PART NUMBER	PART NAME	NO. REQ'D	MODEL	YEAR 19___
<b>Miscellaneous Kits—Continued</b>				
8EL 99360	Kit (fuel pump strainer)-consists of the following (1) 49B-9364 Gasket (1) 8EL-9365 Strainer	1	9L,9H,0L,0H,1L,1H	49-51
8CM 99525	Kit (carburetor float and float spring)-consists of the following (1) 8CM-9550 Float (1) 8CM-9958 Spring	1	9L,9H,0L,0H,1L,1H	49-51
8H 7004603	Kit (cigar lighter element)-consists of the following as (1) 51A-7004616-A Element	1 reqd	9L,9H,0L,0H,1L,1H	49-51
HAK 7221942-A	Kit (door lock and sleeve)-outside-RH-Briggs & Stratton-consists of the following (1) 0A-7022002-A Spring (1) 0M-7222004-A Cover	1	0L,0H,1L,1H	50-51
HAK 7221942-B	Kit (door lock and sleeve)-outside-RH-Hurd Lock-consists of the following (1) 0A-7022002-B Spring (1) 0A-7222004-B Cover	1	0L,0H,1L,1H	50-51
HAK 7221943-A	Kit (door lock and sleeve)-outside-LH-Briggs & Stratton-consists of the following (1) 0A-7022003-A Spring (1) 0M-7222005-A Cover	1	0L,0H,1L,1H	50-51
HAK 7221943-B	Kit (door lock and sleeve)-outside-LH-Hurd Lock-consists of the following (1) 0A-7022003-B Spring (1) 0M-7222005-B Cover	1	0L,0H,1L,1H	50-51